

## FEATURES

- 16-bit resolution with no missing codes**
- 8-channel multiplexer with choice of inputs**
- Unipolar single-ended**
- Differential (GND sense)**
- Pseudobipolar**
- Throughput: 250 kSPS**
- INL: -2.5 LSB minimum,  $\pm 0.4$  LSB typical, +2.5 LSB maximum**
- Dynamic range: 93.8 dB**
- SINAD: 91 dB typical at 20 kHz,  $V_{REF} = 5$  V**
- THD: -100 dB at 20 kHz**
- Analog input range: 0 V to  $V_{REF}$  with  $V_{REF}$  up to VDD**
- Multiple reference types**
  - Internal selectable 2.5 V or 4.096 V
  - External buffered (up to 4.096 V)
  - External (up to VDD)
- Internal temperature sensor (TEMP)**
- Channel sequencer, selectable 1-pole filter, busy indicator**
- No pipeline delay, SAR architecture**
- Single-supply 2.3 V to 5.5 V operation with 1.8 V to 5.5 V logic interface**
- Serial interface compatible with SPI, MICROWIRE, QSPI, and DSP**
- Power dissipation**
  - 3.5 mW typical at 2.5 V, 200 kSPS
  - 12.5 mW typical at 5 V, 250 kSPS
- Standby current: 50 nA**
- Low cost grade available**
- Known Good Die (KGD): these die are fully guaranteed to data sheet specifications.**

## APPLICATIONS

- Multichannel system monitoring**
- Battery-powered equipment**
- Medical instruments: ECG/EKG**
- Mobile communications: GPS**
- Power line monitoring**
- Data acquisition**
- Seismic data acquisition systems**
- Instrumentation**
- Process control**

## FUNCTIONAL BLOCK DIAGRAM

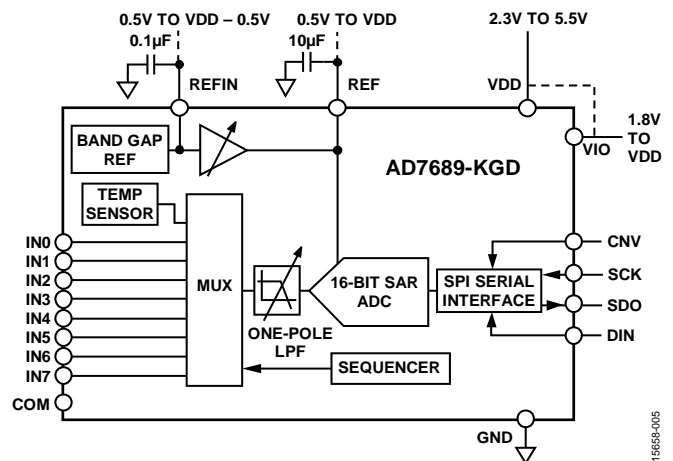

Figure 1. Composite View

## GENERAL DESCRIPTION

The AD7689-KGD is an 8-channel, 16-bit, charge redistribution successive approximation register (SAR) analog-to-digital converter (ADC) that operates from a single power supply, VDD.

The AD7689-KGD contains all components for use in a multi-channel, low power data acquisition system, including a true 16-bit SAR ADC with no missing codes; an 8-channel low crosstalk multiplexer that is useful for configuring the inputs as single-ended (with or without ground sense), differential, or bipolar; an internal low drift reference (selectable 2.5 V or 4.096 V) and buffer; a temperature sensor; a selectable one-pole filter; and a sequencer that is useful when channels are continuously scanned in order.

The AD7689-KGD uses a simple SPI interface for writing to the configuration register and receiving conversion results. The SPI interface uses a separate supply, VIO, which is set to the host logic level. Power dissipation scales with throughput.

The AD7689-KGD is specified from  $-40^{\circ}\text{C}$  to  $+125^{\circ}\text{C}$ .

Additional application and technical information can be found in the [AD7689](#) data sheet.

## TABLE OF CONTENTS

Features .....	1
Applications.....	1
Functional Block Diagram .....	1
General Description .....	1
Revision History .....	2
Specifications.....	3
Timing Specifications .....	6

Absolute Maximum Ratings .....	8
ESD Caution.....	8
Pin Configuration and Function Descriptions.....	9
Outline Dimensions .....	10
Die Specifications and Assembly Recommendations .....	10
Ordering Guide .....	10

## REVISION HISTORY

### 7/2019—Rev. C to Rev. D

Changes to Features Section and General Description Section ...	1
Changes to Integral Linearity Error Parameter, Offset Error Parameter, Signal-to-Noise Ratio (SNR) Parameter, and Signal-to-Noise-and-Distortion Ratio (SINAD) Parameter, Table 1 .....	3
Changes to Power Dissipation Parameter and Temperature Range Parameter, Table 2.....	5
Change to Conversion Time Parameter, Table 3 .....	6
Changes to Conversion time Parameter, Falling Edge to Data Valid Relay Parameter, and Low SDO D15 MSB Valid Parameter, Table 4.....	7
Changes to Ordering Guide .....	10

### 1/2019—Rev. B to Rev. C

Changes to Gain Error Match Parameter, Table 1 and Offset Error Match, Table 1.....	3
Changes to CNV Rising Edge to Data Available Parameter, Table 3 .....	6
Changes to CNV Rising Edge to Data Available Parameter, Table 4 .....	7

### 2/2018—Rev. A to Rev. B

Changes to Features Section .....	1
Changes to Table 1.....	3

### 10/2017—Rev. 0 to Rev. A

Changed Metal Mask Die Image Section to Functional Block Diagram Section .....	1
Changes to Figure 1.....	1

### 7/2017—Revision 0: Initial Version

## SPECIFICATIONS

VDD = 2.3 V to 5.5 V, VIO = 1.8 V to VDD, REF voltage ( $V_{REF}$ ) = VDD, all specifications  $T_{MIN}$  to  $T_{MAX}$ , unless otherwise noted.

Table 1.

Parameter	Test Conditions/Comments	Min	Typ	Max	Unit
RESOLUTION		16			Bits
ANALOG INPUT					
Voltage Range	Unipolar mode	0		$+V_{REF}$	V
	Bipolar mode	$-V_{REF}/2$		$+V_{REF}/2$	V
Absolute Input Voltage	Positive input, unipolar and bipolar modes	-0.1		$V_{REF} + 0.1$	V
	Negative or COM input, unipolar mode	-0.1		+0.1	V
	Negative or COM input, bipolar mode	$V_{REF}/2 - 0.1$	$V_{REF}/2$	$V_{REF}/2 + 0.1$	V
Analog Input Common-Mode Rejection Ratio (CMRR)	Input frequency ( $f_{IN}$ ) = 250 kHz		68		dB
Leakage Current at 25°C	Acquisition phase		1		nA
THROUGHPUT					
Conversion Rate					
Full Bandwidth <sup>1</sup>	VDD = 4.5 V to 5.5 V	0		250	kSPS
	VDD = 2.3 V to 4.5 V	0		200	kSPS
¼ Bandwidth <sup>1</sup>	VDD = 4.5 V to 5.5 V	0		62.5	kSPS
	VDD = 2.3 V to 4.5 V	0		50	kSPS
Transient Response	Full-scale step, full bandwidth			1.8	µs
	Full-scale step, ¼ bandwidth			14.5	µs
ACCURACY					
No Missing Codes		16			Bits
Integral Linearity Error	$T_A \leq 85^\circ\text{C}$	-2.5	±0.4	+2.5	LSB <sup>2</sup>
	$T_A > 85^\circ\text{C}$	-3.0	±0.4	+3.0	LSB <sup>2</sup>
Differential Linearity Error		-1	±0.25	+2	LSB <sup>2</sup>
Transition Noise	REF = VDD = 5 V		0.5		LSB <sup>2</sup>
Gain Error		-24	±1	+24	LSB <sup>2</sup>
Gain Error Match		-6	±0.5	+6	LSB <sup>2</sup>
Gain Error Temperature Drift			±1		ppm/°C
Offset Error	VDD = 4.5 V to 5.5 V, $T_A \leq 85^\circ\text{C}$	-8	±1	+8	LSB <sup>2</sup>
	VDD = 4.5 V to 5.5 V, $T_A > 85^\circ\text{C}$	-11		+11	LSB <sup>2</sup>
	VDD = 2.3 V to 4.5 V		±5		LSB <sup>2</sup>
Offset Error Match		-6	±0.5	+6	LSB <sup>2</sup>
Offset Error Temperature Drift			±1		ppm/°C
Power Supply Sensitivity	VDD = 5 V ± 5%		±1.5		LSB <sup>2</sup>
AC ACCURACY <sup>3</sup>					
Dynamic Range			93.8		dB <sup>4</sup>
Signal-to-Noise Ratio (SNR)	$f_{IN} = 20 \text{ kHz}, V_{REF} = 5 \text{ V}$	88.5	91		dB <sup>4</sup>
	$f_{IN} = 20 \text{ kHz}, V_{REF} = 4.096 \text{ V}$ , internal REF, $T_A \leq 85^\circ\text{C}$	87	90.5		dB <sup>4</sup>
	$f_{IN} = 20 \text{ kHz}, V_{REF} = 4.096 \text{ V}$ , internal REF, $T_A > 85^\circ\text{C}$	86			dB <sup>4</sup>
	$f_{IN} = 20 \text{ kHz}, V_{REF} = 2.5 \text{ V}$ , internal REF	83.5	86		dB <sup>4</sup>
Signal-to-Noise-and-Distortion Ratio (SINAD)	$f_{IN} = 20 \text{ kHz}, V_{REF} = 5 \text{ V}, T_A \leq 85^\circ\text{C}$	88.5	91		dB <sup>4</sup>
	$f_{IN} = 20 \text{ kHz}, V_{REF} = 5 \text{ V}, T_A > 85^\circ\text{C}$	87.5			dB <sup>4</sup>
	$f_{IN} = 20 \text{ kHz}, V_{REF} = 5 \text{ V}$ , -60 dB input		33.5		dB <sup>4</sup>
	$f_{IN} = 20 \text{ kHz}, V_{REF} = 4.096 \text{ V}$ internal REF, $T_A \leq 85^\circ\text{C}$	87.5	90		dB <sup>4</sup>

Parameter	Test Conditions/Comments	Min	Typ	Max	Unit
Total Harmonic Distortion (THD) Spurious-Free Dynamic Range (SFDR) Channel to Channel Crosstalk	$f_{IN} = 20 \text{ kHz}$ , $V_{REF} = 4.096 \text{ V}$ internal REF, $T_A > 85^\circ\text{C}$	85.5			$\text{dB}^4$
	$f_{IN} = 20 \text{ kHz}$ , $V_{REF} = 2.5 \text{ V}$ internal REF	84.5	86		$\text{dB}^4$
	$f_{IN} = 20 \text{ kHz}$		-100		$\text{dB}^4$
	$f_{IN} = 20 \text{ kHz}$		110		$\text{dB}^4$
	$f_{IN} = 100 \text{ kHz}$ on adjacent channel(s)		-125		$\text{dB}^4$
SAMPLING DYNAMICS					
-3 dB Input Bandwidth	Full bandwidth		1.7		MHz
	$\frac{1}{4}$ bandwidth		0.425		MHz
Aperture Delay	$V_{DD} = 5 \text{ V}$		2.5		ns

<sup>1</sup> The bandwidth is set in the configuration register.

<sup>2</sup> LSB means least significant bit. With the 5 V input range, one LSB is 76.3  $\mu\text{V}$ .

<sup>3</sup> With  $V_{DD} = 5 \text{ V}$ , unless otherwise noted.

<sup>4</sup> All specifications expressed in decibels are referred to a full-scale input FSR and tested with an input signal at 0.5 dB below full scale, unless otherwise specified.

VDD = 2.3 V to 5.5 V, VIO = 1.8 V to VDD, V<sub>REF</sub> = VDD, all specifications T<sub>MIN</sub> to T<sub>MAX</sub>, unless otherwise noted.

Table 2.

Parameter	Test Conditions/Comments	Min	Typ	Max	Unit
<b>INTERNAL REFERENCE</b>					
REF Output Voltage	2.5 V at 25°C	2.490	2.500	2.510	V
	4.096 V at 25°C	4.086	4.096	4.106	V
REFIN Output Voltage <sup>1</sup>	2.5 V at 25°C		1.2		V
	4.096 V at 25°C		2.3		V
REF Output Current			±300		µA
Temperature Drift			±10		ppm/°C
Line Regulation	VDD = 5 V ± 5%		±15		ppm/V
Long-Term Drift	1000 hours		50		ppm
Turn-On Settling Time	Reference capacitance (C <sub>REF</sub> ) = 10 µF		5		ms
<b>EXTERNAL REFERENCE</b>					
Voltage Range	REF input	0.5		VDD + 0.3	V
	REFIN input (buffered)	0.5		VDD – 0.5	V
Current Drain <sup>2</sup>	250 kSPS, REF = 5 V		50		µA
<b>TEMPERATURE SENSOR</b>					
Output Voltage <sup>3</sup>	25°C		283		mV
Temperature Sensitivity			1		mV/°C
<b>DIGITAL INPUTS</b>					
Logic Levels					
Input Voltage					
Low, V <sub>IL</sub>		-0.3		+0.3 × VIO	V
High, V <sub>IH</sub>		0.7 × VIO		VIO + 0.3	V
Input Current					
Low, I <sub>IL</sub>		-1		+1	µA
High, I <sub>IH</sub>		-1		+1	µA
<b>DIGITAL OUTPUTS</b>					
Data Format <sup>4</sup>					
Pipeline Delay <sup>5</sup>					
Output Voltage					
Low, V <sub>OL</sub>	Sink current (I <sub>SINK</sub> ) = 500 µA			0.4	V
High, V <sub>OH</sub>	Source current (I <sub>SOURCE</sub> ) = -500 µA	VIO – 0.3			V
<b>POWER SUPPLIES</b>					
VDD <sup>6</sup>	Specified performance	2.3		5.5	V
VIO	Specified performance	1.8		VDD + 0.3	V
Standby Current <sup>7, 8</sup>	VDD and VIO = 5 V at 25°C		50		nA
Power Dissipation	VDD = 2.5 V, 100 SPS throughput		1.7		µW
	VDD = 2.5 V, 200 kSPS throughput		3.5		mW
	VDD = 5 V, 250 kSPS throughput, T <sub>A</sub> ≤ 85°C		12.5	18	mW
	VDD = 5 V, 250 kSPS throughput, T <sub>A</sub> > 85°C			19	mW
	VDD = 5 V, 250 kSPS throughput with internal reference, T <sub>A</sub> ≤ 85°C		15.5	21	mW
Energy per Conversion	VDD = 5 V, 250 kSPS throughput with internal reference, T <sub>A</sub> > 85°C			22	mW
	VDD = 5 V		60		nJ
<b>TEMPERATURE RANGE</b>					
Specified Performance	T <sub>MIN</sub> to T <sub>MAX</sub>	-40		+125	°C

<sup>1</sup> This is the output from the internal band gap.

<sup>2</sup> This is an average current and scales with throughput.

<sup>3</sup> The output voltage is internal and present on a dedicated multiplexer input.

<sup>4</sup> Unipolar mode is serial 16-bit straight binary. Bipolar mode is serial 16-bit twos complement.

<sup>5</sup> Conversion results available immediately after completed conversion.

<sup>6</sup> The minimum VDD supply must be 3 V when the 2.5 V internal reference is enabled, and 4.5 V when the 4.096 V internal reference is enabled.

<sup>7</sup> With all digital inputs forced to VIO or GND as required.

<sup>8</sup> During acquisition phase.

**TIMING SPECIFICATIONS**

VDD = 4.5 V to 5.5 V, VIO = 1.8 V to VDD, all specifications T<sub>MIN</sub> to T<sub>MAX</sub>, unless otherwise noted.

Table 3.

Parameter <sup>1</sup>	Symbol	Min	Typ	Max	Unit
CONVERSION TIME CNV Rising Edge to Data Available	t <sub>CONV</sub>			2.6	μs
ACQUISITION TIME	t <sub>ACQ</sub>	1.8			μs
TIME BETWEEN CONVERSIONS	t <sub>CYC</sub>	4.0			μs
DATA WRITE/READ DURING CONVERSION	t <sub>DATA</sub>			1.2	μs
SCK					
Period	t <sub>SCK</sub>	t <sub>DSDO</sub> + 2			ns
Low Time	t <sub>SCKL</sub>	11			ns
High Time	t <sub>SCKH</sub>	11			ns
Falling Edge to Data Remains Valid	t <sub>HSDO</sub>	4			ns
Falling Edge to Data Valid Delay	t <sub>DSDO</sub>			18	ns
VIO Above 2.7 V,				23	ns
VIO Above 2.3 V				28	ns
VIO Above 1.8 V					ns
CNV					
Pulse Width	t <sub>CNVH</sub>	10			ns
Low to SDO D15 MSB Valid	t <sub>EN</sub>			18	ns
VIO Above 2.7 V				22	ns
VIO Above 2.3 V				25	ns
VIO Above 1.8 V				32	ns
High or Last SCK Falling Edge to SDO High Impedance	t <sub>DIS</sub>				ns
Low to SCK Rising Edge	t <sub>CLSCK</sub>	10			ns
DIN					
Valid Setup Time from SCK Rising Edge	t <sub>SDIN</sub>	5			ns
Valid Hold Time from SCK Rising Edge	t <sub>HDIN</sub>	5			ns

<sup>1</sup> See Figure 2 and Figure 3 for load conditions.

VDD = 2.3 V to 4.5 V, VIO = 1.8 V to VDD, all specifications T<sub>MIN</sub> to T<sub>MAX</sub>, unless otherwise noted.

Table 4.

Parameter <sup>1</sup>	Symbol	Min	Typ	Max	Unit
CONVERSION TIME CNV Rising Edge to Data Available	t <sub>CONV</sub>			3.6	μs
ACQUISITION TIME	t <sub>ACQ</sub>	1.8			μs
TIME BETWEEN CONVERSIONS	t <sub>CYC</sub>	5			μs
DATA WRITE/READ DURING CONVERSION	t <sub>DATA</sub>			1.2	μs
SCK					
Period	t <sub>SCK</sub>	t <sub>DSDO</sub> + 2			ns
Low Time	t <sub>SCKL</sub>	12			ns
High Time	t <sub>SCKH</sub>	12			ns
Falling Edge to Data Remains Valid	t <sub>HSDO</sub>	5			ns
Falling Edge to Data Valid Delay	t <sub>DSDO</sub>				
VIO Above 3 V				30	ns
VIO Above 2.7 V				36	ns
VIO Above 2.3 V				44	ns
VIO Above 1.8 V				54	ns
CNV					
Pulse Width	t <sub>CNVH</sub>	10			ns
Low to SDO D15 MSB Valid	t <sub>EN</sub>				
VIO Above 3 V				27	ns
VIO Above 2.7 V				33	ns
VIO Above 2.3 V				41	ns
VIO Above 1.8 V				51	ns
High or Last SCK Falling Edge to SDO High Impedance	t <sub>DIS</sub>			50	ns
Low to SCK Rising Edge	t <sub>CLSCK</sub>	10			ns
DIN					
Valid Setup Time from SCK Rising Edge	t <sub>SDIN</sub>	5			ns
Valid Hold Time from SCK Rising Edge	t <sub>HDIN</sub>	5			ns

<sup>1</sup> See Figure 2 and Figure 3 for load conditions.

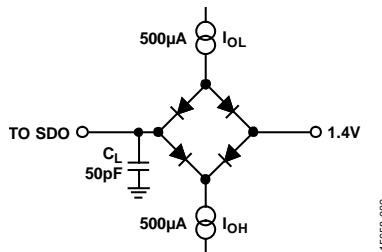
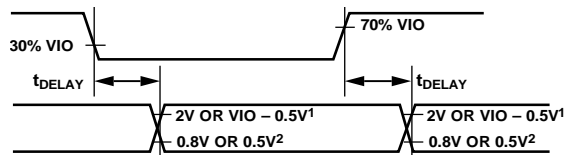

Figure 2. Load Circuit for Digital Interface Timing



<sup>1</sup>2V IF VIO ABOVE 2.5V, VIO - 0.5V IF VIO BELOW 2.5V.  
<sup>2</sup>0.8V IF VIO ABOVE 2.5V, 0.5V IF VIO BELOW 2.5V.

Figure 3. Voltage Levels for Timing

## ABSOLUTE MAXIMUM RATINGS

Table 5.

Parameter	Rating
Analog Inputs IN0 to IN7, COM	GND – 0.3 V to VDD + 0.3 V or VDD ± 130 mA
REF, REFIN	GND – 0.3 V to VDD + 0.3 V
Supply Voltages	
VDD, VIO to GND	–0.3 V to +7 V
VIO to VDD	–0.3 V to VDD + 0.3 V
DIN, CNV, SCK to GND	–0.3 V to VIO + 0.3 V
SDO to GND	–0.3 V to VIO + 0.3 V
Storage Temperature Range	–65°C to +150°C
Junction Temperature	150°C

Stresses at or above those listed under Absolute Maximum Ratings may cause permanent damage to the product. This is a stress rating only; functional operation of the product at these or any other conditions above those indicated in the operational section of this specification is not implied. Operation beyond the maximum operating conditions for extended periods may affect product reliability.

### ESD CAUTION



**ESD (electrostatic discharge) sensitive device.** Charged devices and circuit boards can discharge without detection. Although this product features patented or proprietary protection circuitry, damage may occur on devices subjected to high energy ESD. Therefore, proper ESD precautions should be taken to avoid performance degradation or loss of functionality.



## PIN CONFIGURATION AND FUNCTION DESCRIPTIONS

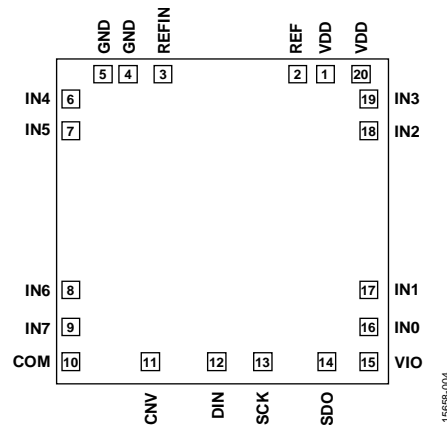

Figure 4. Pad Configuration

Table 6. Pad Function Descriptions

Pad No.	Mnemonic	X-Axis ( $\mu\text{m}$ )	Y-Axis ( $\mu\text{m}$ )	Pad Type <sup>1</sup>	Description
1	VDD	+650	+1079	AI	Power Supply. Nominally 2.5 V to 5.5 V.
2	REF	+475	+1078	AI	Reference Input/Output.
3	REFIN	-473	+1078	AI	Internal Reference Output/Reference Buffer Input.
4	GND	-659	+1079	P	Power Supply Ground.
5	GND	-838	+1079	P	Power Supply Ground.
6	IN4	-1085	+892	AI	Analog Input Channel 4.
7	IN5	-1085	+653	AI	Analog Input Channel 5.
8	IN6	-1085	-528	AI	Analog Input Channel 6.
9	IN7	-1085	-769	AI	Analog Input Channel 7.
10	COM	-1085	-1015	P	Common Channel Input. All input channels, IN[7:0], can be referenced to a common-mode point of 0 V or $V_{REF}/2$ V.
11	CNV	-519	-1087	DI	Conversion Input. On the rising edge, CNV initiates the conversion. During conversion, if CNV is held low, the busy indicator is enabled.
12	DIN	-71	-1087	DI	Data Input. Use this input for writing to the 14-bit configuration register. The configuration register can be written to during and after conversion.
13	SCK	+231	-1087	DI	Serial Data Clock Input. This input is used to clock out the data on SDO and clock in data on.
14	SDO	+667	-1087	DO	Serial Data Output.
15	VIO	+1079	-1056	P	Input/Output Interface Digital Power. Nominally at the same supply as the host interface (1.8 V, 2.5 V, 3 V, or 5 V).
16	IN0	+1085	-769	AI	Analog Input Channel 0.
17	IN1	+1085	-528	AI	Analog Input Channel 1.
18	IN2	+1085	+653	AI	Analog Input Channel 2.
19	IN3	+1085	+894	AI	Analog Input Channel 3.
20	VDD	+997	+1079	P	Power Supply. Nominally 2.5 V to 5.5 V.

<sup>1</sup> AI is analog input, P is power, DI is digital input, and DO is digital output.

## OUTLINE DIMENSIONS

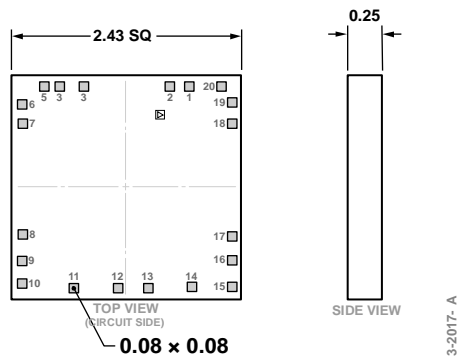

Figure 5. 20-Pad Bare Die [CHIP]  
(C-20-2)  
Dimensions shown in millimeters

## DIE SPECIFICATIONS AND ASSEMBLY RECOMMENDATIONS

Table 7. Die Specifications

Parameter	Value	Unit
Scribe Line Width	80 × 80	μm
Die Size (Maximum Size)	2430 × 2430	μm
Thickness	250	μm
Bond Pads (Minimum Size)	80 × 80	μm
Bond Pad Composition	0.5 AlCu	%
Backside	Standard assembly die attach	Not applicable
Passivation	Oxynitride	Not applicable
Chip Size	2350 × 2350	μm

Table 8. Assembly Recommendations

Assembly Component	Recommendation
Die Attach	Epoxy adhesive
Bonding Method	Gold ball <sup>1</sup> or aluminum wedge
Bonding Sequence	Bond pin five first

<sup>1</sup> Evaluate the gold wire for suitability before use at elevated temperatures for extended durations.

## ORDERING GUIDE

Model	Temperature Range	Package Description	Package Option
AD7689-KGD-PT	−40°C to +125°C	20-Pad Bare Die [CHIP]	C-20-2

## X-ON Electronics

Largest Supplier of Electrical and Electronic Components

*Click to view similar products for [Data Conversion IC Development Tools](#) category:*

*Click to view products by [Analog Devices](#) manufacturer:*

Other Similar products are found below :

[EVAL-AD5063EBZ](#) [EVAL-AD5422LFEBZ](#) [EVAL-AD7265EDZ](#) [EVAL-AD7641EDZ](#) [EVAL-AD7674EDZ](#) [EVAL-AD7719EBZ](#) [EVAL-AD7767-1EDZ](#) [EVAL-AD7995EBZ](#) [AD9114-DPG2-EBZ](#) [AD9211-200EBZ](#) [AD9251-20EBZ](#) [AD9251-65EBZ](#) [AD9255-125EBZ](#) [AD9284-250EBZ](#) [AD9613-170EBZ](#) [AD9627-125EBZ](#) [AD9629-20EBZ](#) [AD9709-EBZ](#) [AD9716-DPG2-EBZ](#) [AD9737A-EBZ](#) [AD9787-DPG2-EBZ](#) [AD9993-EBZ](#) [DAC8555EVM](#) [ADS5482EVM](#) [ADS8372EVM](#) [EVAL-AD5061EBZ](#) [EVAL-AD5062EBZ](#) [EVAL-AD5443-DBRDZ](#) [EVAL-AD5570SDZ](#) [EVAL-AD7450ASDZ](#) [EVAL-AD7677EDZ](#) [EVAL-AD7992EBZ](#) [EVAL-AD7994EBZ](#) [AD9119-MIX-EBZ](#) [AD9148-M5375-EBZ](#) [AD9204-80EBZ](#) [AD9233-125EBZ](#) [AD9265-105EBZ](#) [AD9265-80EBZ](#) [AD9608-125EBZ](#) [AD9629-80EBZ](#) [AD9648-125EBZ](#) [AD9649-20EBZ](#) [AD9650-80EBZ](#) [AD9765-EBZ](#) [AD9767-EBZ](#) [AD9778A-DPG2-EBZ](#) [ADS8322EVM](#) [LM96080EB/NOPB](#) [EVAL-AD5445SDZ](#)