

Evaluating the ADA4523-1 36 V, Low Noise, Zero Drift, Operational Amplifier

FEATURES

- Full featured evaluation board for the [ADA4523-1](#)
- Enables efficient prototyping
- User defined circuit configuration
- Edge mounted SMA connector provisions
- Shutdown function for low power application

EVALUATION KIT CONTENTS

EVAL-ADA4523-1ARMZ

EQUIPMENT NEEDED

- Dual output power supply
- Signal generator
- Oscilloscope
- 3 banana jack to grabber cables
- 2 SMA to BNC male cables

DOCUMENTS NEEDED

[ADA4523-1](#) data sheet

GENERAL DESCRIPTION

The EVAL-ADA4523-1ARMZ allows the evaluation of the [ADA4523-1](#) single-channel, 8-lead, micro small outline package (MSOP) operational amplifier. The ADA4523-1 in this evaluation board is configured as a noninverting amplifier with a gain of 101. The [ADA4523-1](#) has a typical gain bandwidth product of 4 MHz. When using a gain of 101, the useable bandwidth of the [ADA4523-1](#) is limited to approximately 39.6 kHz. This limitation in bandwidth acts as a low-pass filter that rejects the artifacts generated by the 330 kHz internal chopping frequency of the [ADA4523-1](#).

The EVAL-ADA4523-1 layout lessens the thermocouple effects of the trace and components that introduce offset voltages greater than the maximum offset voltage of the [ADA4523-1](#) by carefully constructing the nodes connected to the inverting and noninverting inputs. The [ADA4523-1](#) also features a shutdown mode for low power applications. Test point provisions for the SD and SD_COM pins are placed on the EVAL-ADA4523-1ARMZ to easily use the shutdown function.

EVALUATION BOARD PHOTOGRAPHS

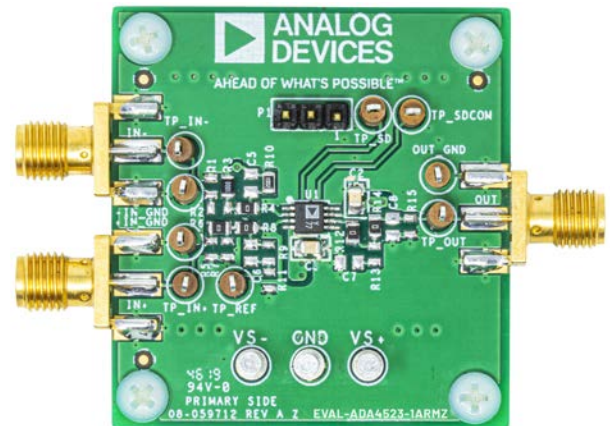

Figure 1. EVAL-ADA4523-1ARMZ, Primary Side



Figure 2. EVAL-ADA4523-1ARMZ, Secondary Side

The EVAL-ADA4523-1ARMZ mainly consists of 0805 sized resistors and capacitors to ensure simple installation except for the bypass capacitors. The 10 μF bypass capacitors (C1 and C4) have a 2220 package size to accommodate a higher voltage rating because the [ADA4523-1](#) has a maximum supply of 55 V. For full details on the [ADA4523-1](#), see the [ADA4523-1](#) data sheet, which must be consulted in conjunction with this user guide when using the EVAL-ADA4523-1ARMZ.

TABLE OF CONTENTS

Features	1	Power Supply Consideration	3
Evaluation Kit Contents.....	1	Initial Board Configuration	3
Equipment Needed.....	1	Using the Initial Noninverting Configuration of the EVAL- ADA4523-1ARMZ with a Gain of 101.....	3
Documents Needed.....	1	Evaluation Board Schematics and Layout.....	4
General Description	1	Ordering Information.....	6
Evaluation Board Photographs.....	1	Bill of Materials.....	6
Revision History	2		
Evaluation Board Quick Start Procedure	3		

REVISION HISTORY

2/2020—Revision 0: Initial Version

EVALUATION BOARD QUICK START PROCEDURE

The following sections outline the basic prepopulated configuration of the EVAL-ADA4523-1ARMZ required to test the basic functionality of the [ADA4523-1](#).

POWER SUPPLY CONSIDERATION

Use the turret pins, VS+, VS-, and GND, to power up the EVAL-ADA4523-1ARMZ. Always connect the proper polarity to the power supply of the EVAL-ADA4523-1ARMZ. To protect the EVAL-ADA4523-1ARMZ from power supply reversal, a Zener diode was installed. Proper supply levels must be strictly followed with a range from +4.5 V to +36 V for single-supply operation and with a range from ± 2.25 V to ± 18 V for dual-supply operation. The EVAL-ADA4523-1ARMZ also comes with preinstalled 10 μ F and 0.1 μ F decoupling capacitors.

INITIAL BOARD CONFIGURATION

Take the following steps to test the basic functionality of the preinstalled EVAL-ADA4523-1ARMZ circuit, which is a noninverting amplifier with a gain of 101:

1. Before connecting anything to the EVAL-ADA4523-1ARMZ, ensure that the power supply and signal generator are powered down.
2. Use three banana jack to grabber cables to connect the turret pins, VS-, GND, and VS+, to negative ground and the positive supply, respectively.
3. Use a Subminiature Version A (SMA) to bayonet nut connector (BNC) male cable to connect the output of the signal generator to the SMA on the EVAL-ADA4523-1ARMZ, IN+.
4. Use another SMA to BNC male cable to connect the SMA connector output of the EVAL-ADA4523-1ARMZ, OUT, to the oscilloscope.

USING THE INITIAL NONINVERTING CONFIGURATION OF THE EVAL-ADA4523-1ARMZ WITH A GAIN OF 101

When the initial board configuration steps are completed, verify the expected output of the ADA4523-1ARMZ when configured as a noninverting amplifier with a gain of 101 as follows:

1. Set the power levels to +15 V for the positive supply rail and -15 V for the negative supply rail.
2. Select a sinewave output for the signal generator. The frequency must be 1 kHz with a magnitude of 40 mV p-p. The offset voltage must be 0 V. Use a high-Z configuration for the output of the signal generator.
3. Set the input or the termination of the oscilloscope to 1 M Ω .
4. Measure or observe the frequency and the peak-to-peak voltage on the oscilloscope.
5. After setting up the connections detailed in the Initial Board Configuration section and applying the different settings for the equipment detailed in Step 1 through Step 4, turn the power supply of the EVAL-ADA4523-1ARMZ on. Ensure that the current consumption is between 1 mA to 3 mA, and that this consumption does not exceed 5 mA.
6. Verify the voltage and current levels of the [ADA4523-1](#).
7. Turn on the signal generator and ensure that the signal generator displays the correct output from Step 2.
8. The oscilloscope then displays the output waveform. Because the EVAL-ADA4523-1ARMZ is configured as a noninverting amplifier with a gain of 101, the output must be a sinewave with a frequency of 1 kHz and a peak-to-peak voltage of approximately 4.04 V.

EVALUATION BOARD SCHEMATICS AND LAYOUT

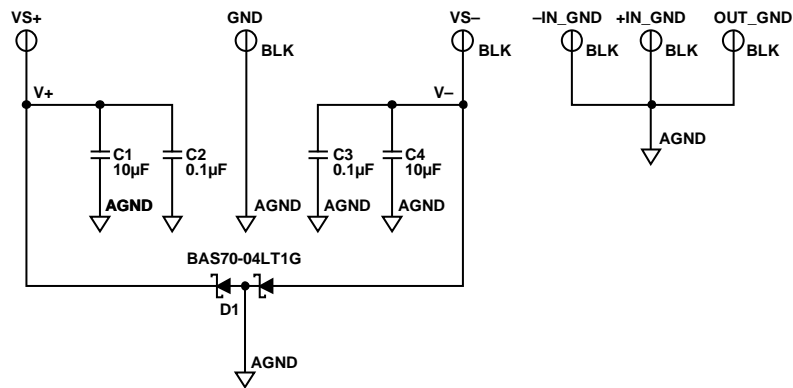

Figure 3. EVAL-ADA4523-2ARMZ Schematic of the Power Supply Pins

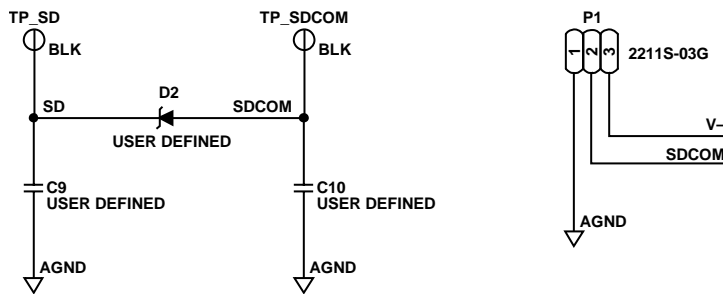

Figure 4. EVAL-ADA4523-2ARMZ Schematic of the Shutdown Circuit

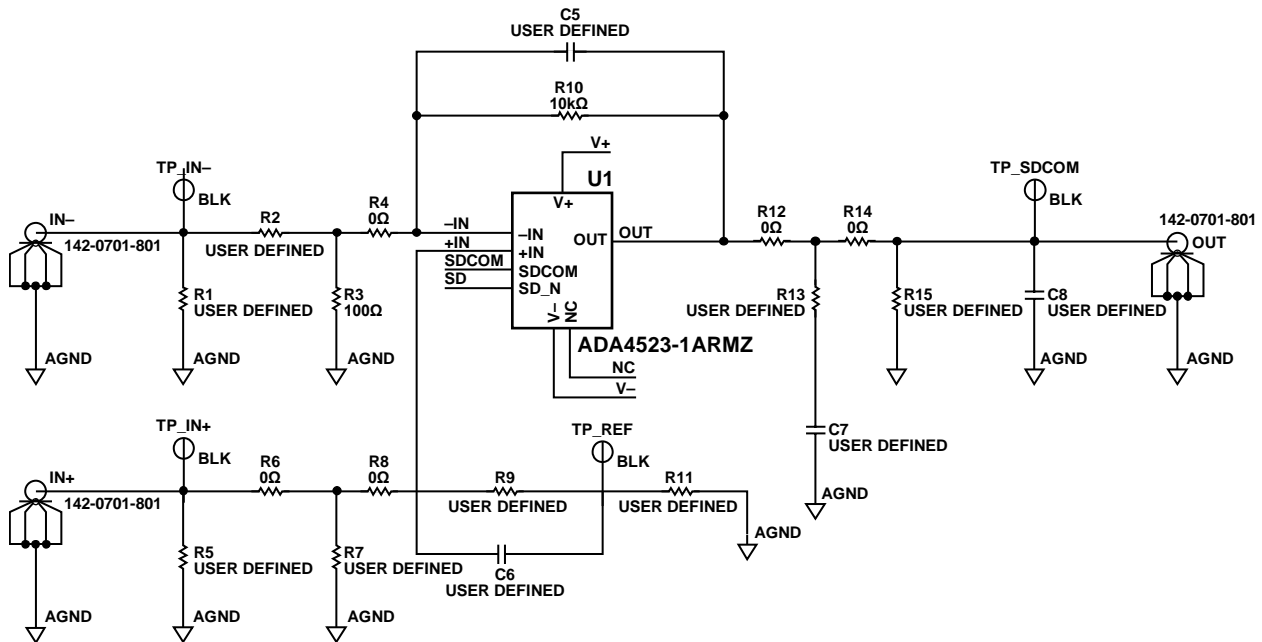

Figure 5. EVAL-ADA4523-2ARMZ Schematic of the Initial Board Configuration (NC Means No Connect)

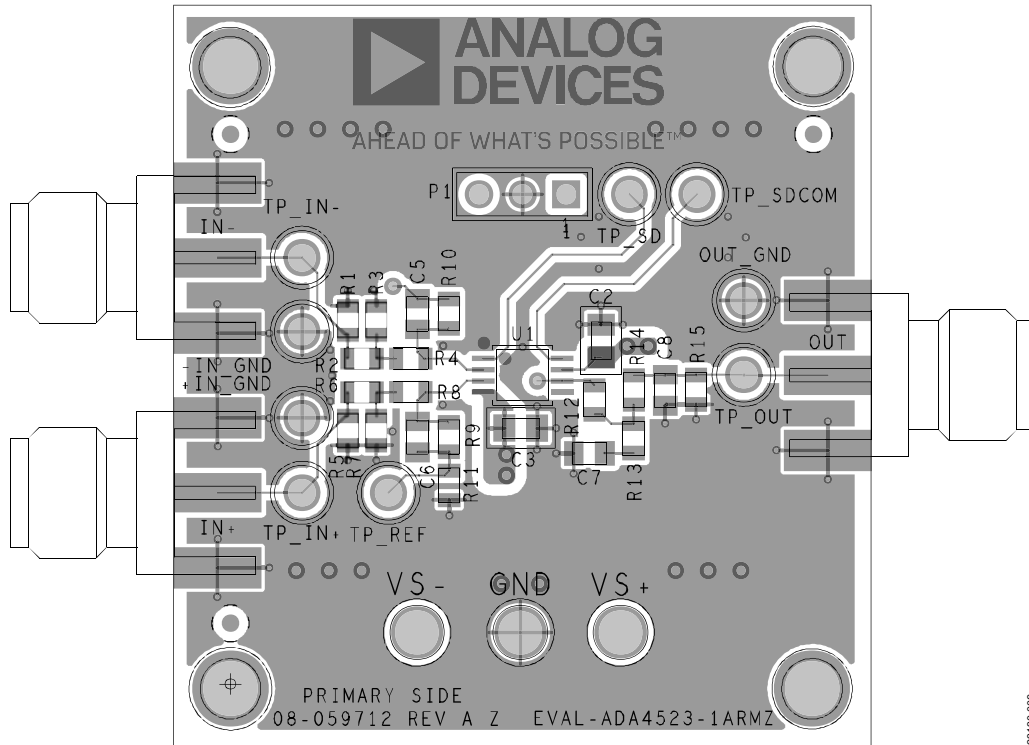

Figure 6. EVAL-ADA4523-2ARMZ Layout, Primary Side

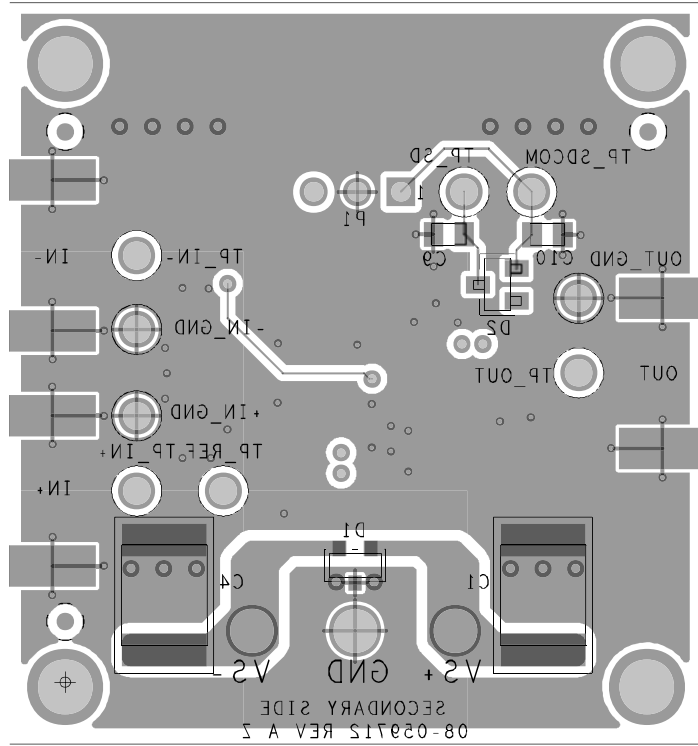

Figure 7. EVAL-ADA4523-2ARMZ Schematic Layout, Secondary Side

ORDERING INFORMATION

BILL OF MATERIALS

Table 1.

Quantity	Reference Designator	Description	Supplier	Part Number
1	U1	36V, low noise, zero drift op amp	Analog Devices, Inc.	ADA4523-1ARMZ
2	C1, C4	Capacitors, X7R, 10 μ F, 2220	AVX Corporation	22201C106MAT2A
2	C2, C3	Capacitors, X7R, 0.1 μ F, 0805	AVX Corporation	08051C104JAT2A
6	C5 to C10	Capacitors, user defined, 0805	Not applicable	Not applicable
5	R4, R6, R8, R12, R14	Resistors, thick film, 0 Ω , 0805	Vishay	CRCW08050000Z0EA
1	R3	Resistor, thin film, 100 Ω , 0805	Panasonic	ERA-6AEB101V
1	R10	Resistor, thin film, 10 k Ω , 0805	Panasonic	ERA-6AEB103V
8	R1, R2, R5, R7, R9, R11, R13, R15	Resistors, user defined, 0805	Not applicable	Not applicable
1	D1	Schottky diode, SOT-23	ON Semiconductor	BAS70-04LT1G
1	D2	Zener diode, user defined, SOT-23	Not applicable	Not applicable
3	GND, VS+, VS-	Terminal turrets	Mill-Max	2501-2-00-80-00-00-07-0
9	+IN_GND, -IN_GND, OUT_GND, TP_IN+, TP_IN-, TP_OUT, TP_REF, TP_SD, TP_SDCOM	Test points, black	Keystone Electronics	5006
3	IN+, IN-, OUT	SMA end launch connectors	Cinch Connectivity Solutions	142-0701-801
1	P1	Single row, printed circuit board (PCB) headers, three contacts, 2.54 mm pitch	Multicomp	2211S-03G

**ESD Caution**

ESD (electrostatic discharge) sensitive device. Charged devices and circuit boards can discharge without detection. Although this product features patented or proprietary protection circuitry, damage may occur on devices subjected to high energy ESD. Therefore, proper ESD precautions should be taken to avoid performance degradation or loss of functionality.

Legal Terms and Conditions

By using the evaluation board discussed herein (together with any tools, components documentation or support materials, the "Evaluation Board"), you are agreeing to be bound by the terms and conditions set forth below ("Agreement") unless you have purchased the Evaluation Board, in which case the Analog Devices Standard Terms and Conditions of Sale shall govern. Do not use the Evaluation Board until you have read and agreed to the Agreement. Your use of the Evaluation Board shall signify your acceptance of the Agreement. This Agreement is made by and between you ("Customer") and Analog Devices, Inc. ("ADI"), with its principal place of business at One Technology Way, Norwood, MA 02062, USA. Subject to the terms and conditions of the Agreement, ADI hereby grants to Customer a free, limited, personal, temporary, non-exclusive, non-sublicensable, non-transferable license to use the Evaluation Board FOR EVALUATION PURPOSES ONLY. Customer understands and agrees that the Evaluation Board is provided for the sole and exclusive purpose referenced above, and agrees not to use the Evaluation Board for any other purpose. Furthermore, the license granted is expressly made subject to the following additional limitations: Customer shall not (i) rent, lease, display, sell, transfer, assign, sublicense, or distribute the Evaluation Board; and (ii) permit any Third Party to access the Evaluation Board. As used herein, the term "Third Party" includes any entity other than ADI, Customer, their employees, affiliates and in-house consultants. The Evaluation Board is NOT sold to Customer; all rights not expressly granted herein, including ownership of the Evaluation Board, are reserved by ADI. CONFIDENTIALITY. This Agreement and the Evaluation Board shall all be considered the confidential and proprietary information of ADI. Customer may not disclose or transfer any portion of the Evaluation Board to any other party for any reason. Upon discontinuation of use of the Evaluation Board or termination of this Agreement, Customer agrees to promptly return the Evaluation Board to ADI. ADDITIONAL RESTRICTIONS. Customer may not disassemble, decompile or reverse engineer chips on the Evaluation Board. Customer shall inform ADI of any occurred damages or any modifications or alterations it makes to the Evaluation Board, including but not limited to soldering or any other activity that affects the material content of the Evaluation Board. Modifications to the Evaluation Board must comply with applicable law, including but not limited to the RoHS Directive. TERMINATION. ADI may terminate this Agreement at any time upon giving written notice to Customer. Customer agrees to return to ADI the Evaluation Board at that time. LIMITATION OF LIABILITY. THE EVALUATION BOARD PROVIDED HEREUNDER IS PROVIDED "AS IS" AND ADI MAKES NO WARRANTIES OR REPRESENTATIONS OF ANY KIND WITH RESPECT TO IT. ADI SPECIFICALLY DISCLAIMS ANY REPRESENTATIONS, ENDORSEMENTS, GUARANTEES, OR WARRANTIES, EXPRESS OR IMPLIED, RELATED TO THE EVALUATION BOARD INCLUDING, BUT NOT LIMITED TO, THE IMPLIED WARRANTY OF MERCHANTABILITY, TITLE, FITNESS FOR A PARTICULAR PURPOSE OR NON-INFRINGEMENT OF INTELLECTUAL PROPERTY RIGHTS. IN NO EVENT WILL ADI AND ITS LICENSORS BE LIABLE FOR ANY INCIDENTAL, SPECIAL, INDIRECT, OR CONSEQUENTIAL DAMAGES RESULTING FROM CUSTOMER'S POSSESSION OR USE OF THE EVALUATION BOARD, INCLUDING BUT NOT LIMITED TO LOST PROFITS, DELAY COSTS, LABOR COSTS OR LOSS OF GOODWILL. ADI'S TOTAL LIABILITY FROM ANY AND ALL CAUSES SHALL BE LIMITED TO THE AMOUNT OF ONE HUNDRED US DOLLARS (\$100.00). EXPORT. Customer agrees that it will not directly or indirectly export the Evaluation Board to another country, and that it will comply with all applicable United States federal laws and regulations relating to exports. GOVERNING LAW. This Agreement shall be governed by and construed in accordance with the substantive laws of the Commonwealth of Massachusetts (excluding conflict of law rules). Any legal action regarding this Agreement will be heard in the state or federal courts having jurisdiction in Suffolk County, Massachusetts, and Customer hereby submits to the personal jurisdiction and venue of such courts. The United Nations Convention on Contracts for the International Sale of Goods shall not apply to this Agreement and is expressly disclaimed.

X-ON Electronics

Largest Supplier of Electrical and Electronic Components

Click to view similar products for [Amplifier IC Development Tools](#) category:

Click to view products by [Analog Devices](#) manufacturer:

Other Similar products are found below :

[EVAL-ADCMP566BCPZ](#) [EVAL-ADCMP606BKSZ](#) [AD8013AR-14-EBZ](#) [AD8033AKS-EBZ](#) [AD8044AR-EBZ](#) [AD8225-EVALZ](#)
[ADA4859-3ACP-EBZ](#) [ADA4862-3YR-EBZ](#) [DEM-OPA-SO-2B](#) [AD744JR-EBZ](#) [AD8023AR-EBZ](#) [AD8030ARJ-EBZ](#) [AD8040ARU-EBZ](#)
[AD8073JR-EBZ](#) [AD813AR-14-EBZ](#) [AD848JR-EBZ](#) [ADA4858-3ACP-EBZ](#) [ADA4922-1ACP-EBZ](#) [551600075-001/NOPB](#) [DEM-OPA-SO-](#)
[2E](#) [THS7374EVM](#) [EVAL-ADCMP553BRMZ](#) [EVAL-ADCMP608BKSZ](#) [MIOP 42109](#) [EVAL-ADCMP609BRMZ](#) [MAX9928EVKIT+](#)
[MAX9636EVKIT+](#) [MAX9611EVKIT](#) [MAX9937EVKIT+](#) [MAX9934TEVKIT+](#) [MAX44290EVKIT#](#) [MAX2644EVKIT](#) [MAX4073EVKIT+](#)
[DEM-OPA-SO-2C](#) [MAX2643EVKIT](#) [ISL28158EVAL1Z](#) [MAX40003EVKIT#](#) [MAX2473EVKIT](#) [MAX2472EVKIT](#) [MAX4223EVKIT](#)
[MAX9700BEVKIT](#) [MADL-011014-001SMB](#) [DC1685A](#) [DEM-OPA-SO-2D](#) [MAX2670EVKIT#](#) [DEM-OPA-SO-1E](#) [AD8137YCP-EBZ](#)
[EVAL-ADA4523-1ARMZ](#) [MAX44242EVKIT#](#) [EVAL-LT5401_32FDAZ](#)