



ADV7604 Evaluation Board User Guide

June 2010

Pr. A

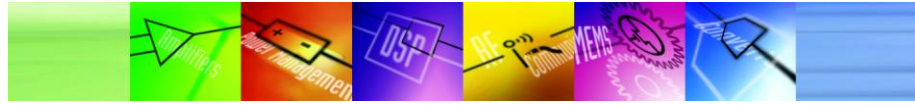

Table of Contents

Table of Contents.....	2
1. Introduction.....	3
2. Evaluation Kit.....	3
3. Initial Configuration.....	4
3.1 Hardware.....	4
3.2 Software.....	5
3.2.1 ATV Benchtop Installation.....	5
3.2.2 Getting Started with ADV Register Control Software.....	5
4. Using the Evaluation Platform.....	7
4.1 ADV7604 Evaluation Board Hardware.....	7
4.1.1 Connecting Input Video.....	8
4.1.2 EDID Configuration.....	8
4.1.3 Powerdown Mode EDID.....	9
4.2 Video Output Module.....	10
4.3 Using Configuration Scripts.....	10
4.4 Using Software Driver.....	11
4.5 Configuring the Motherboard.....	11
5. Updating Files.....	12
5.1 Updating Scripts.....	12
5.2 Updating Defaults.....	12
6. Schematics.....	13
7. Layout.....	22



1. Introduction

This User Guide is intended to provide application support for the ADV7604 evaluation kit. It also provides details on the set up and manual configuration of the evaluation board. Software drivers are available for this evaluation board - a separate user guide is available for these software drivers.

2. Evaluation Kit

Each ADV7604 evaluation kit consists of the following:

- ADV7604 Evaluation Board
- ATV Motherboard
- Video Output Module
- USB cable
- 7.5V DC power supply module
- Evaluation kit CD

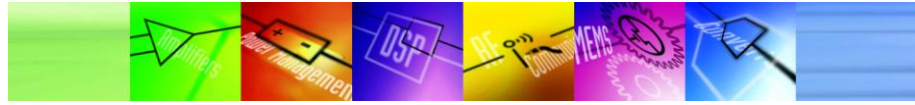

3. Initial Configuration

3.1 Hardware

The ATV evaluation platform is comprised of three modules – the ADV7604 evaluation board, the ATV motherboard and the video output module. To assemble the evaluation platform, plug the ADV7604 evaluation board into the Female AV Input connector of the motherboard and plug the video output module into the Male AV Output connector of the motherboard.

Connect the female connector of the 7.5V DC power supply module supplied with the evaluation kit to the motherboard power connector, J18. Connect the USB cable supplied with the evaluation kit to the motherboard USB connector, J12.

The evaluation platform should now resemble Figure 1.

To turn the evaluation platform on, flick motherboard power switch (S10) to position “ON”. The green power LED (D13) should light and the red “DONE” LED (D3) should light 2 – 3 seconds later. This indicates the eval platform is now ready to use.

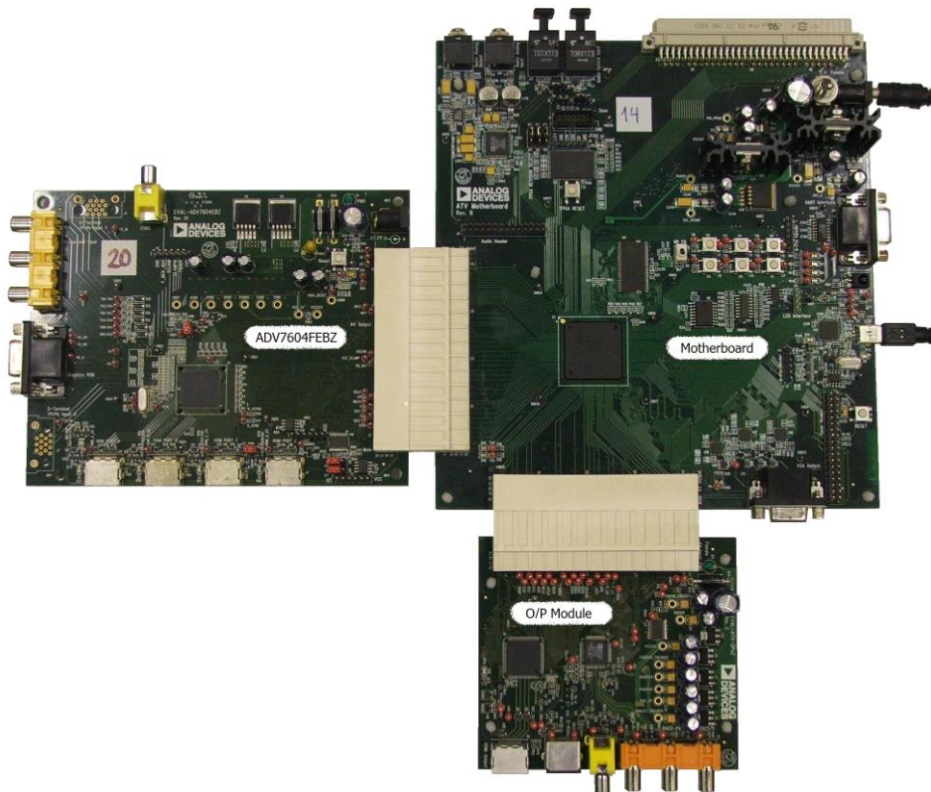
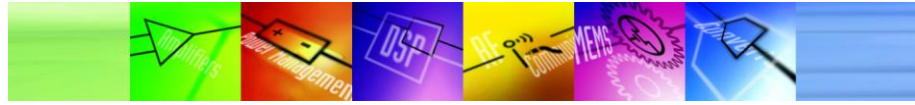

Figure 1 – ATV Evaluation Platform



3.2 Software

3.2.1 ATV Benchtop Installation

All the files necessary to install the ATV Benchtop software are on the evaluation kit CD supplied in the evaluation kit. To install the ATV Benchtop software from the evaluation kit CD, please complete the following steps:

- Copy the ATV Benchtop installer folder to the c:\ drive.
- **Run the file “setup.bat” to begin installation.**
- Follow the installation wizard to complete installation following the on screen instructions including a restart if prompted.

Please note; to install the ATV Benchtop software, you need to be an administrator on the PC the software is being installed on.

3.2.2 Getting Started with ADV Register Control Software

The ADV Register Control software can be used to run example configuration scripts on the ATV Evaluation platform and adjust I2C register settings via USB. In order to launch the ADV Register Control software from the ATV Benchtop, complete the following steps:

- Launch the ATV Benchtop from the Windows “All Programs” list (Start -> All Programs -> Analog Devices -> ATV Benchtop -> ATV Benchtop). The ATV Benchtop control panel as per Figure 2 will appear.

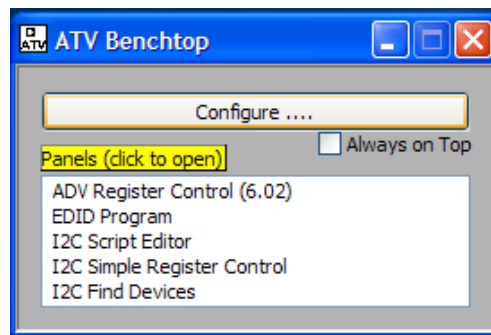

Figure 2 – ATV Benchtop Control

- Select ADV Register Control from the ATV Benchtop control panel.
- Select a script targeting the device on your evaluation platform (ADV7604 in this case) from the ADV Register Program Configuration window as per Figure 3.

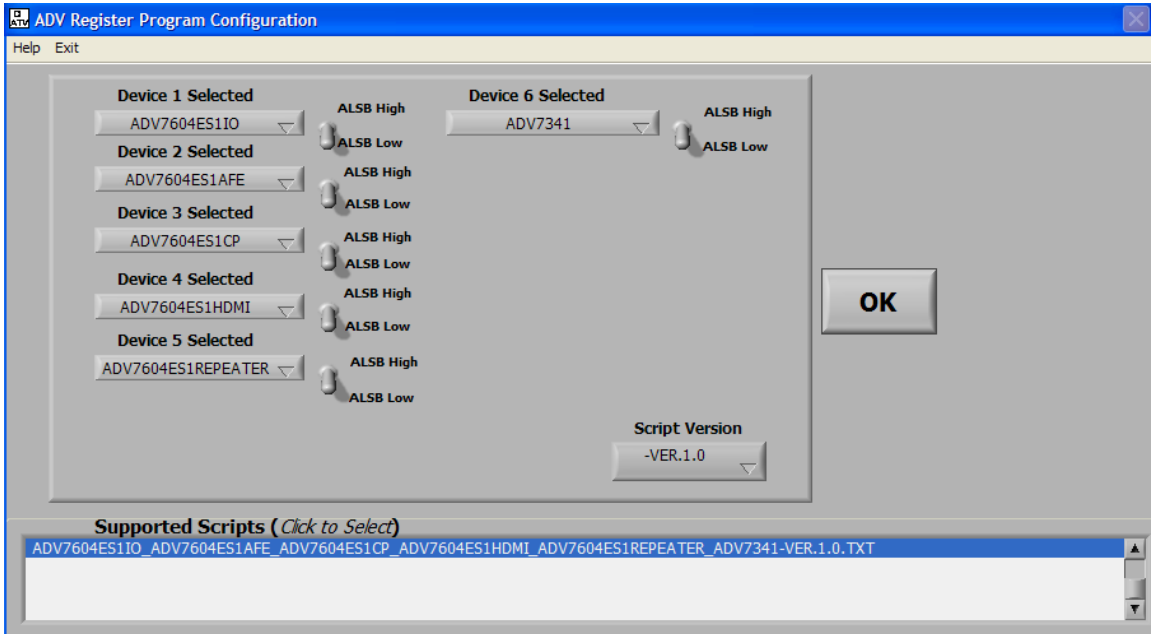
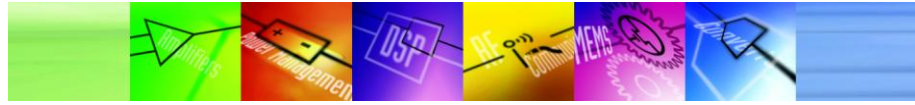

Figure 3 – ADV Register Program Configuration

- Finally, the user can run configuration scripts, change individual bit values, check STDI information and read user write logs from the ADV Register Control Panel as per Figure 4.

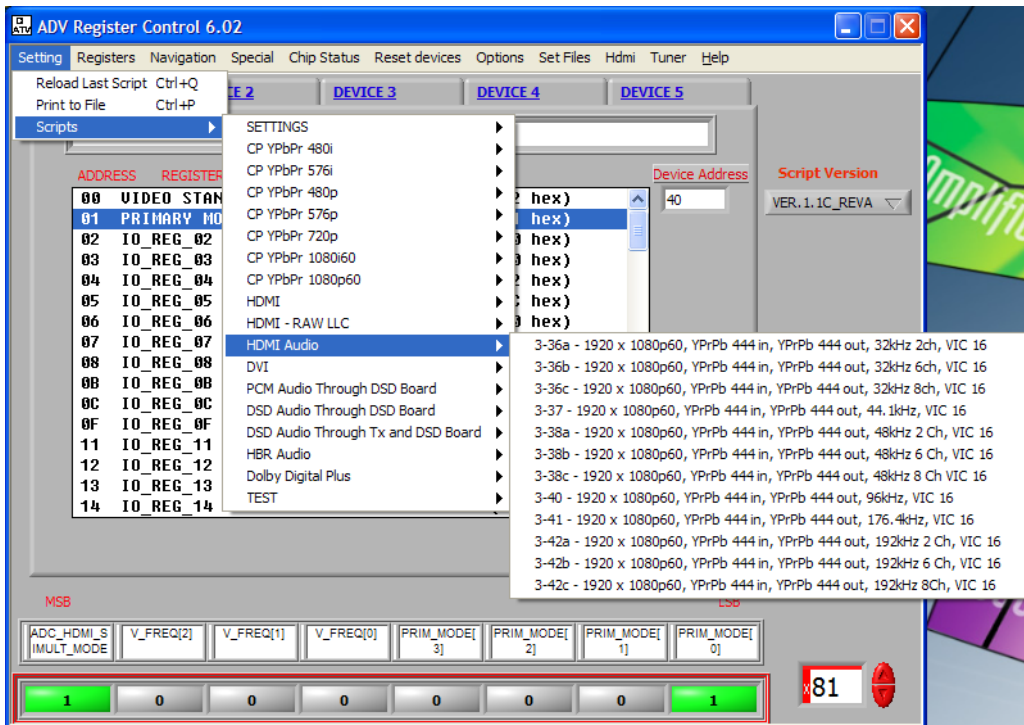

Figure 4 – ADV Register Control Panel



4. Using the Evaluation Platform

4.1 *ADV7604 Evaluation Board Hardware*

The following features of the ADV7604 evaluation board

Figure 5) should be noted

Input Video Connectors

- 4 x HDMI inputs
- 1 x Component input
- 1 x Graphic input
- 2 x D-type inputs (Japanese market only)

Jumpers

- K7 and K8 (external EDID I2C access)
- K6 and K9, K4 and K5, K1 and K2 (not stuffed external EDID I2C access)
- SE_PIN
- SE_PWR

Miscellaneous

- 168 pin male motherboard connector
- Power LED (D1)
- I2C header (P1)

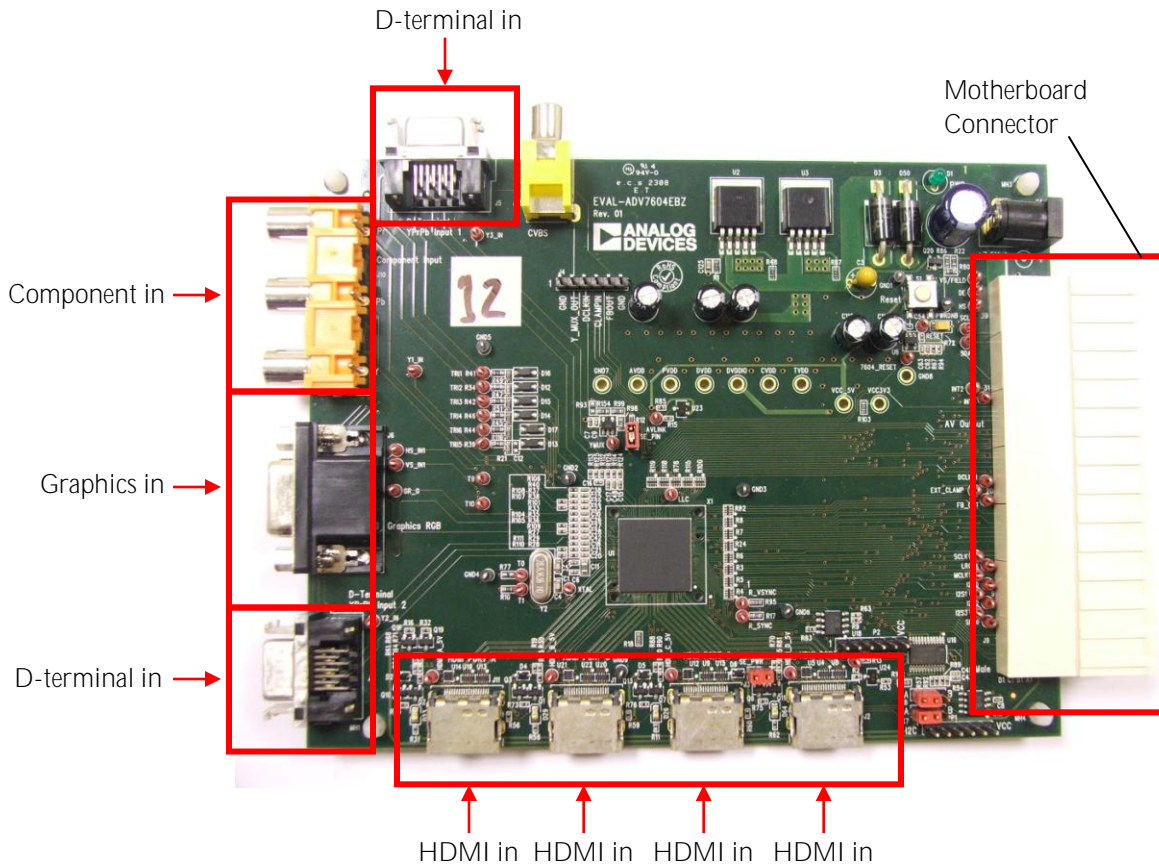
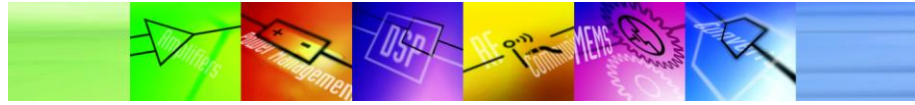

Figure 5 – ADV7604 Evaluation Board

4.1.1 Connecting Input Video

To connect an input video source to the evaluation board, use a suitable cable and one of the input video connectors outlined above. Do not use excessive force when connecting or disconnecting the cables as this may result in damage to the evaluation board.

4.1.2 EDID Configuration

There are two EDID options available to user on the ADV7604 board – an external PROM on port D to which an EDID can be programmed or an internal EDID PROM within the ADV7604.

4.1.2.1 Configuring the External EDID

To program the external PROM (U10) for port D, complete the following procedure:

- Connect the PROM to the I2C bus by putting jumpers K7 and K8 into position B
- Connect the evaluation platform to the as outlined in Section 3

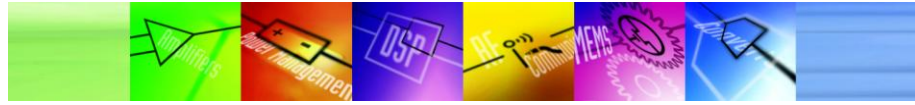

- Launch the “EDID Program” from the ATV Benchtop Control
- Press “Write Hex File...” and browse to the EDID image desired to be programmed
- Under “24LCS22”, select “Program”. Allow the programming to complete
- Verify the programming by selecting “Verify”
- The EDID is now downloaded the external PROM. Reset the jumpers to position A to use the external EDID

4.1.2.2 Configuring the Internal EDID

To program the internal PROM, complete the following procedure:

- Disconnect the external EDID by removing jumpers K7 and K8
- Select the EDID script from the Settings -> Scripts menu in the ADV Register Control Panel

Note: the external EDID PROMs are not stuffed for ports A, B or C. If it is desired to stuff these parts, please consult the evaluation board BOM for details of the required parts.

4.1.3 Powerdown Mode EDID

To evaluate the powerdown mode EDID, the evaluation board should be disconnected from the powered ATV motherboard. A HDMI cable with an active source supplying 5V to the HDMI 5V line should be connected.

The user can then determine whether they want the SPI PROM EDID replicated on ports A, B, C and D or ports A, B, and C by inserting or removing the SE_PIN header respectively.

The user can also disconnect the 5V supply from a source plugged into port D by removing jumper SE_PWR.

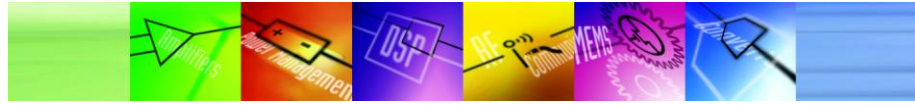

4.2 Video Output Module

The following features of the Video Output Module (Figure 6) should be noted

Output Video Connectors

- 1 x HDMI output
- 1 x Component output
- 1 x CVBS output
- 1 x S Video output

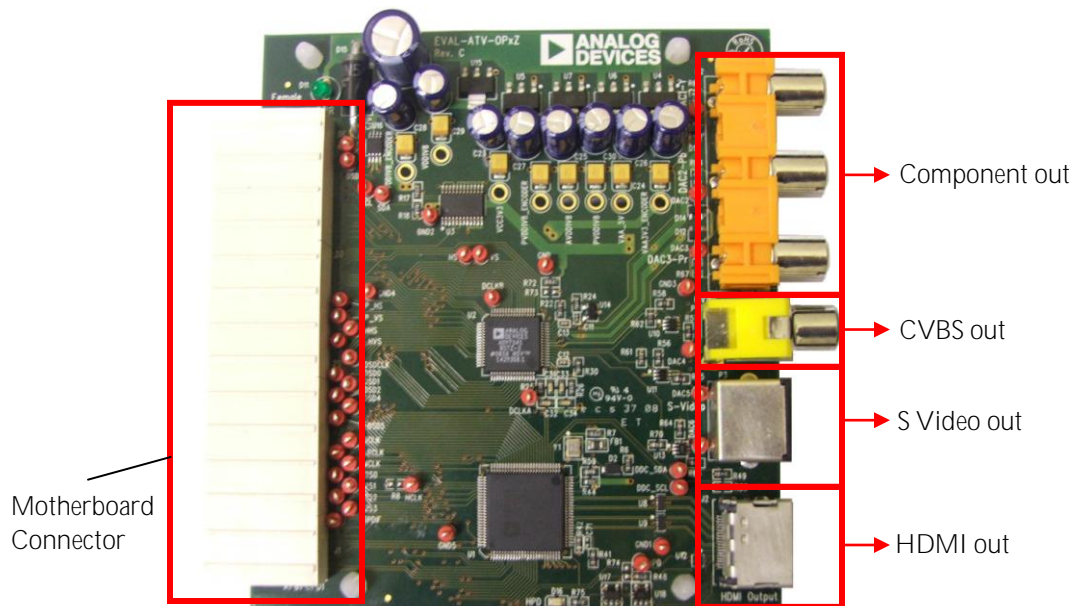

Figure 6 – Video Output Module

4.3 Using Configuration Scripts

The evaluation platform is provided with a set of scripts to provide a fast and easy means of configuring the system to process a wide variety of input video formats. Figure 4 illustrates how a specific script file can be accessed and selected from the ADV Register Control Panel (e.g. Setting -> Scripts -> DESIRED CATEGORY -> DESIRED SCRIPT).

The I2C address of the selected register map is displayed in the “Device Address” indication box. Register maps can be accessed from the ADV Register Control Panel by clicking on the tabs across the screen below the standard toolbar (e.g. DEVICE 1, DEVICE 2). The selected register map name is displayed when the tab is selected.



4.4 Using Software Driver

Some motherboards, by request, are supplied with application code already preloaded to configure and run the ADV7604. The following explains the behaviour of the motherboard interfaces when the application is running

LEDS

- D2 and D4 are on
- D5 flashes during loading of FPGA
- D6, D7, D15 and D16 are on

MB_EN switch

- Driver disabled with switch at position 0. ATV Benchtop may be used.
- Driver enabled with switch at position 1. ATV Benchtop may not be used.

Push buttons

- FPGA_RESET resets the FPGA and reloads the firmware
- S2 – S7 are not used
- S9 resets the ADV7604 evaluation board with no handshaking to the application. If this button is pressed, hot plug must be reasserted.

Serial interface

- If a suitable serial terminal application is connected to the serial port of the ATV motherboard (settings: 115200, 8 bit, none, 1, no flow control) the application provides event and debug messages and allows I2C read and write commands.

4.5 Configuring the Motherboard

The ATV Motherboard is a powerful tool which provides a wide variety of configuration options to experienced users. For more in depth information on using the ATV Motherboard, please consult the following document:

ATV_Motherboard_User_Guide.pdf, Revision 0.

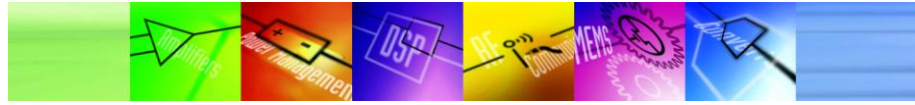

5. Updating Files

The ATV Benchtop software application uses “scripts” and “defaults” to power its user interface. A script contains lists of I2C writes for each supported video mode. A default contains details of the bits in each register map of the target device.

Analog Devices Inc. reserves the right to update any script or default as and when is required. Should this be the case, please use the following procedure to update either a script or a default.

Note: you may need administrative privileges on any machine you are about to undertake these steps on.

5.1 *Updating Scripts*

If provided with a new script, please use the following procedure:

- Close ATV Benchtop
- Open the Program Files folder on the c:/
- Open the Analog Devices folder
- Open the ATV Benchtop folder
- Open the Setup_Files folder
- Copy the new script file into this directory.
- Restart ATV Benchtop

5.2 *Updating Defaults*

If provided with a new default, please use the following procedure:

- Close ATV Benchtop
- Open the Program Files folder on the c:/
- Open the Analog Devices folder
- Open the ATV Benchtop folder
- Open the Defaults folder
- Copy the new default file into this directory.
- Restart ATV Benchtop

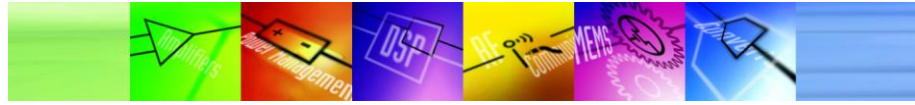

6. Schematics

Place analog inputs as far apart as possible while maintaining similar trace lengths
 Trace impedance of analog inputs to be 75 ohms
 Termination resistors should be placed as close as possible to end of line

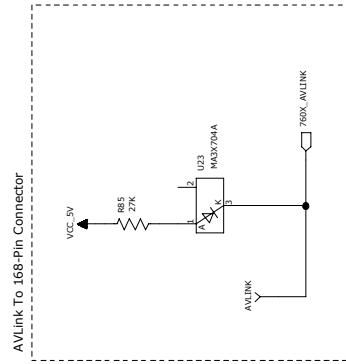
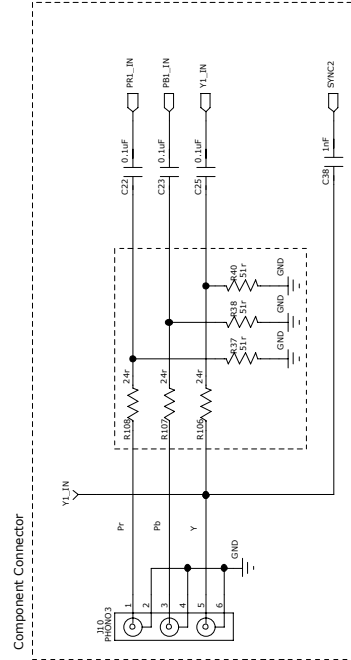
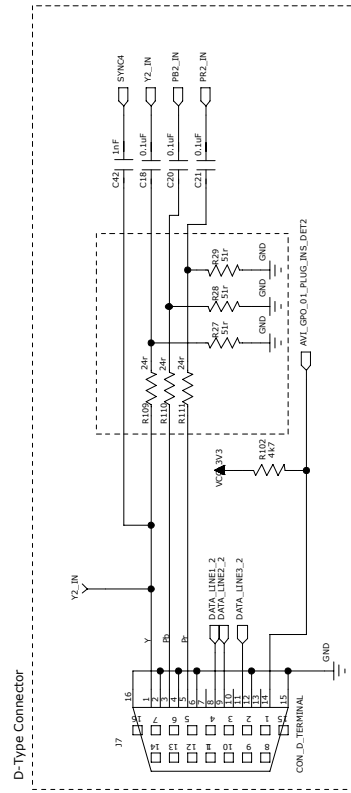
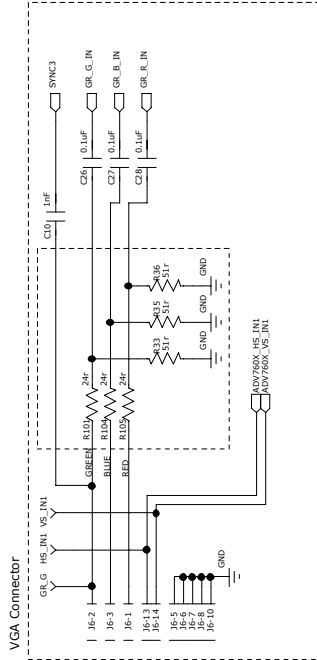
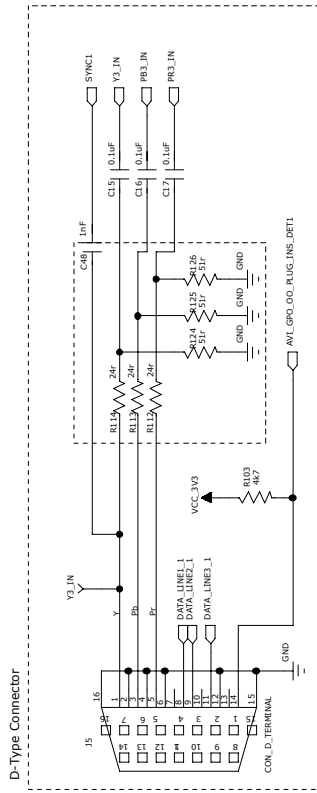

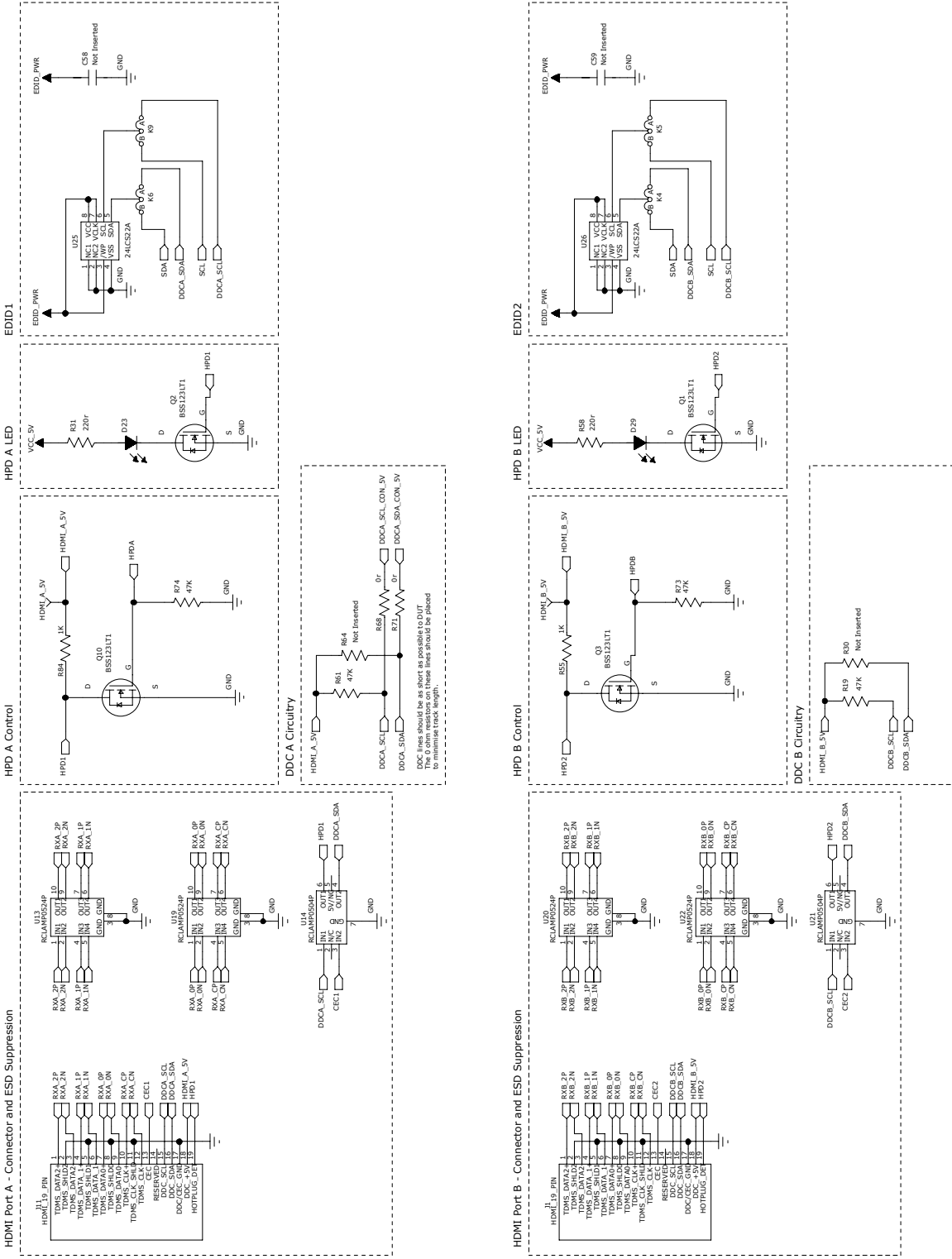
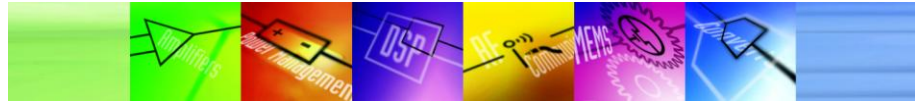

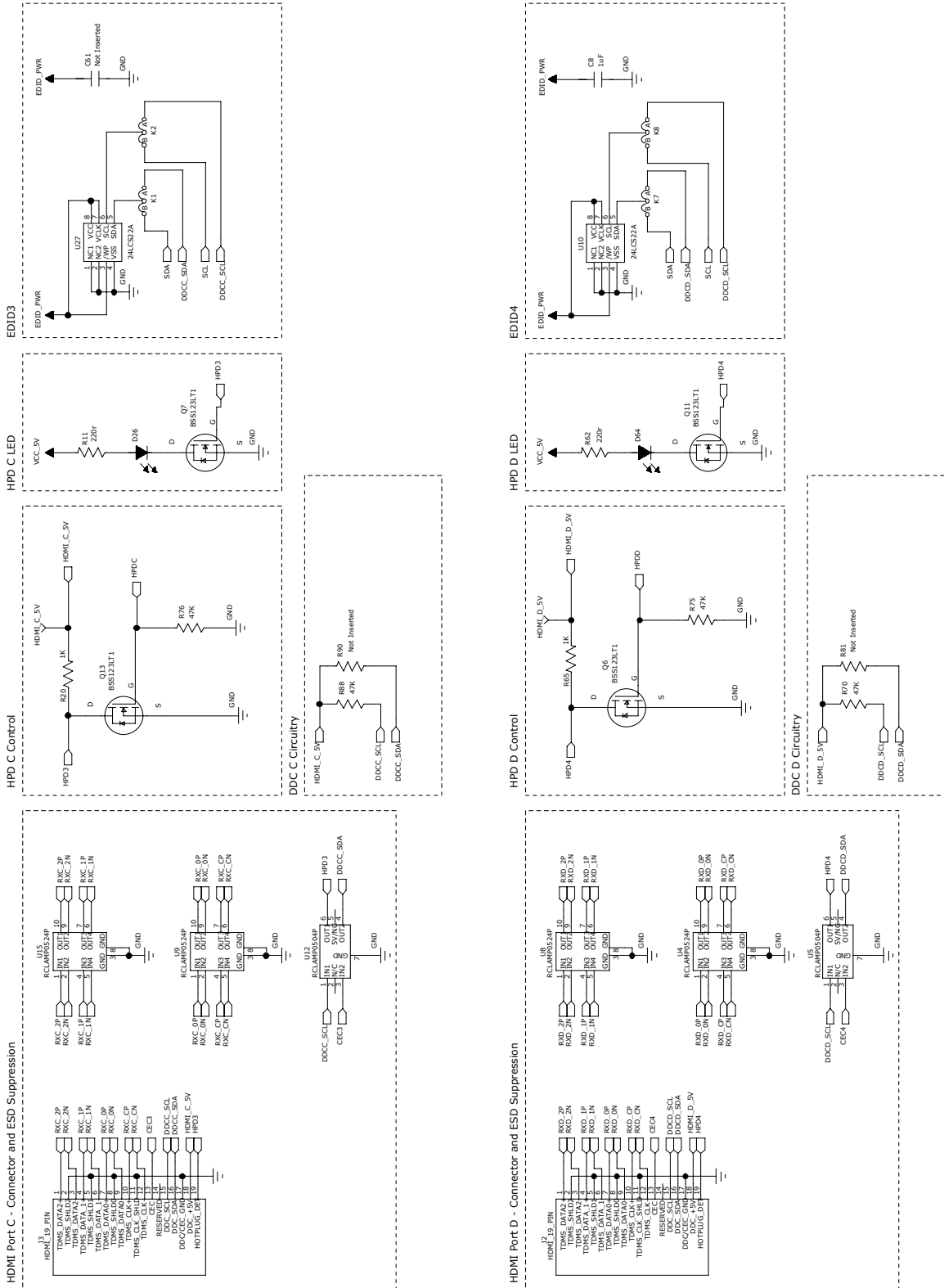

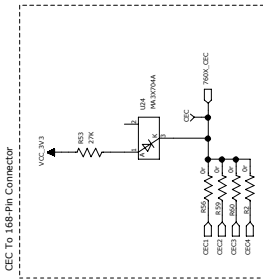
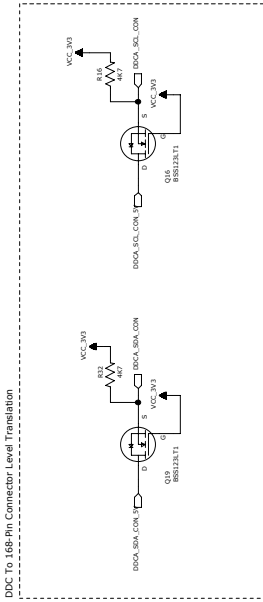

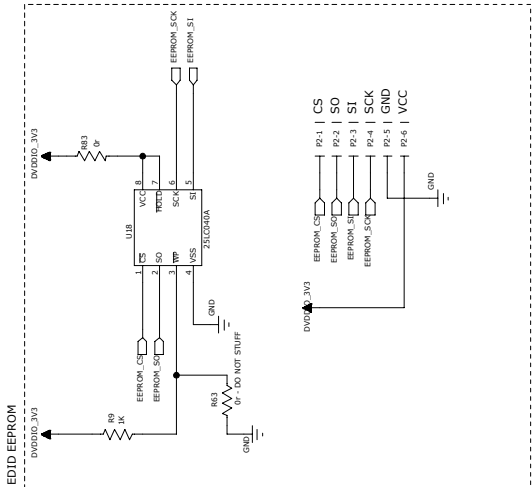
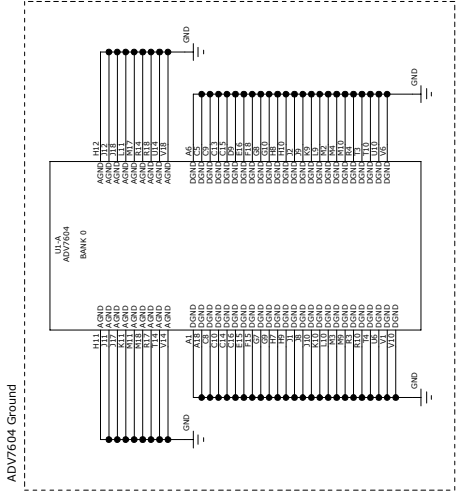
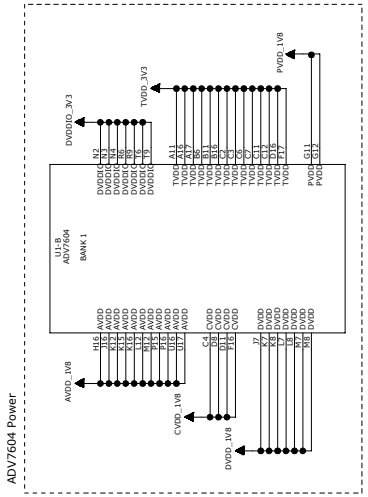
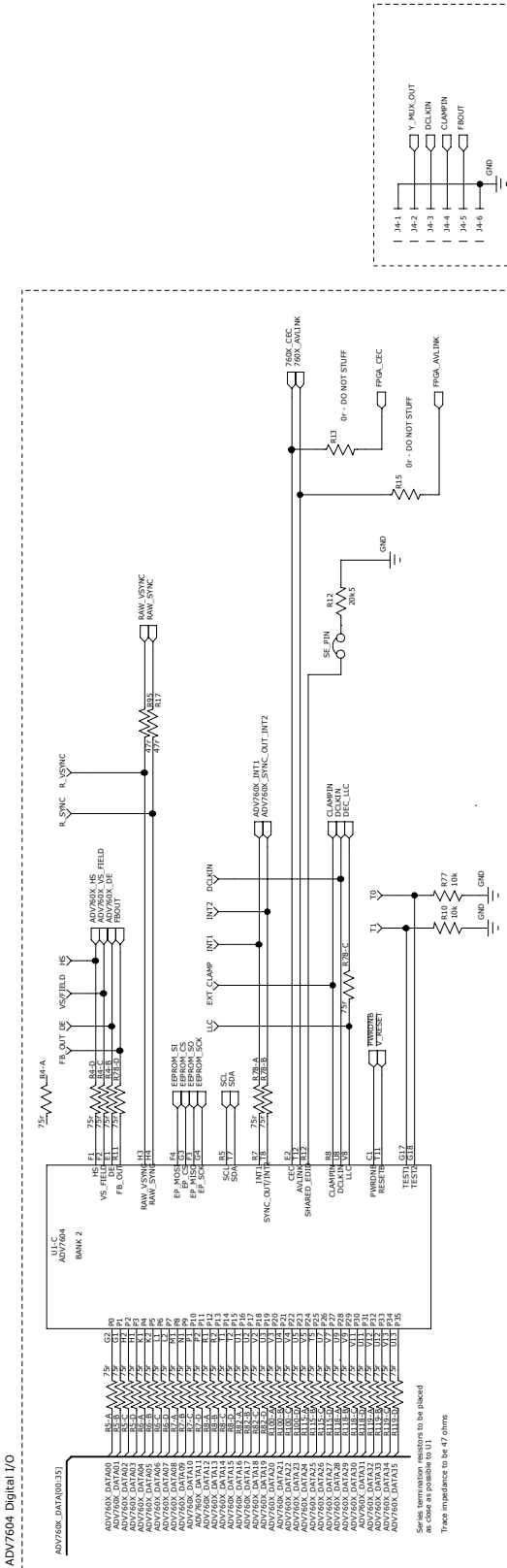
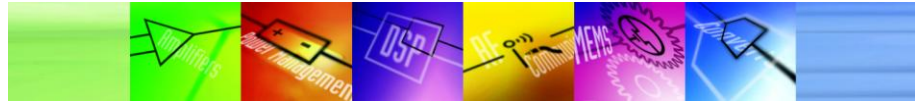

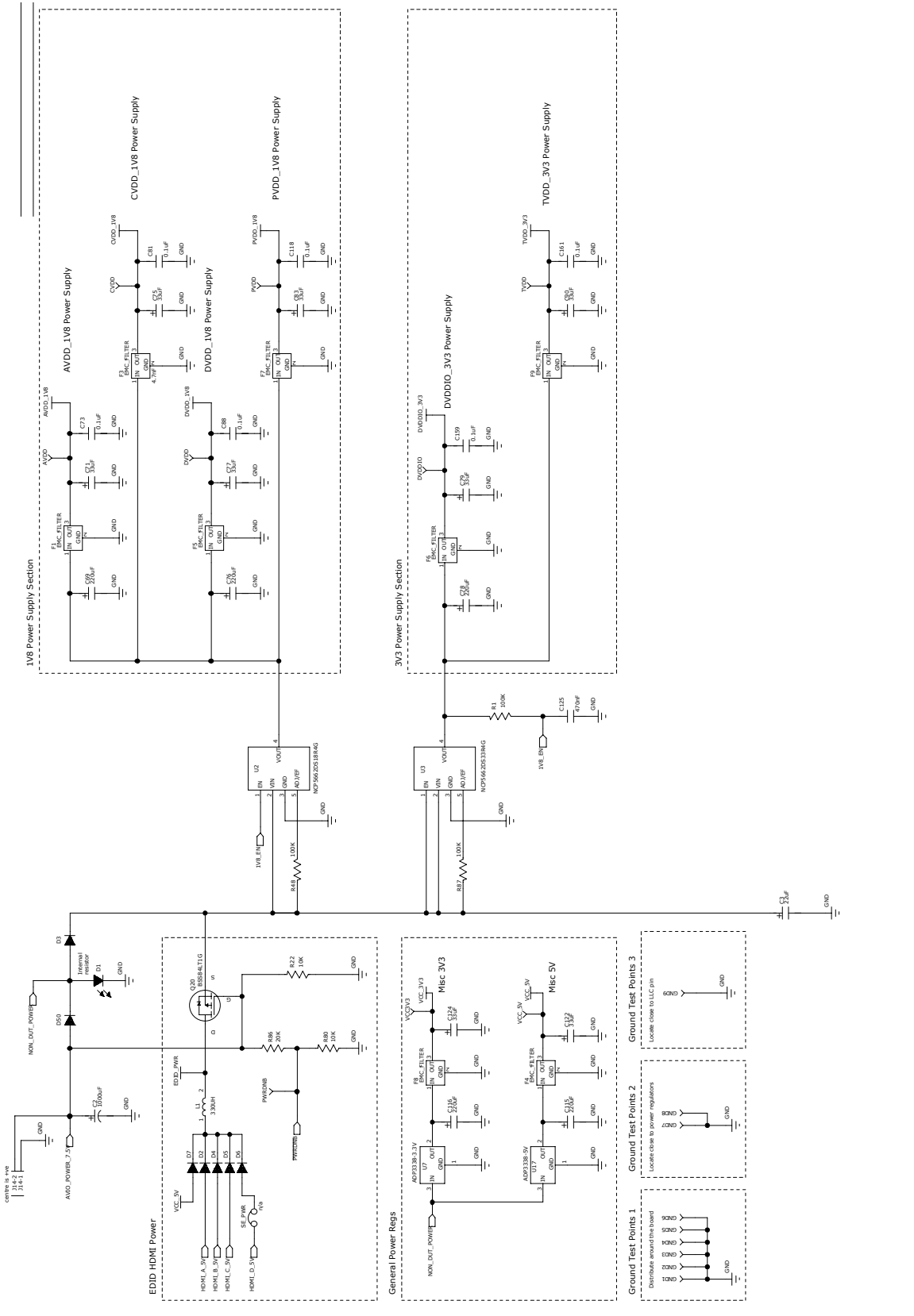
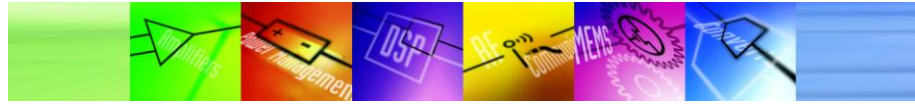

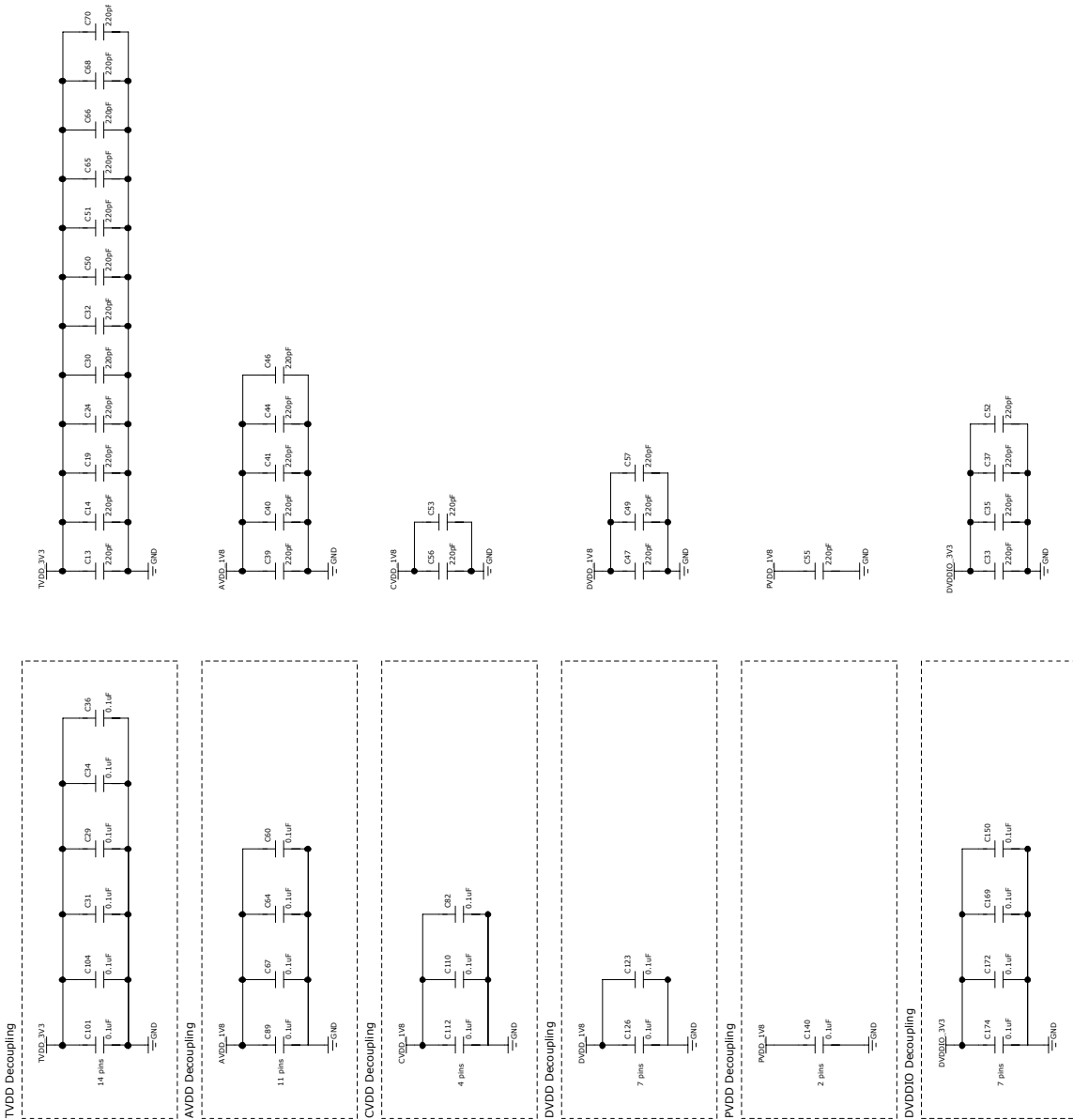
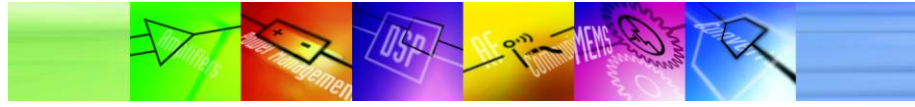

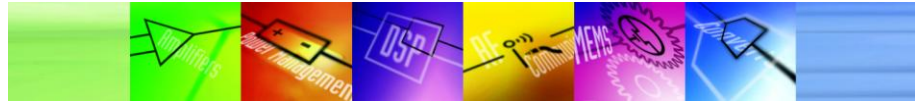

7. Layout

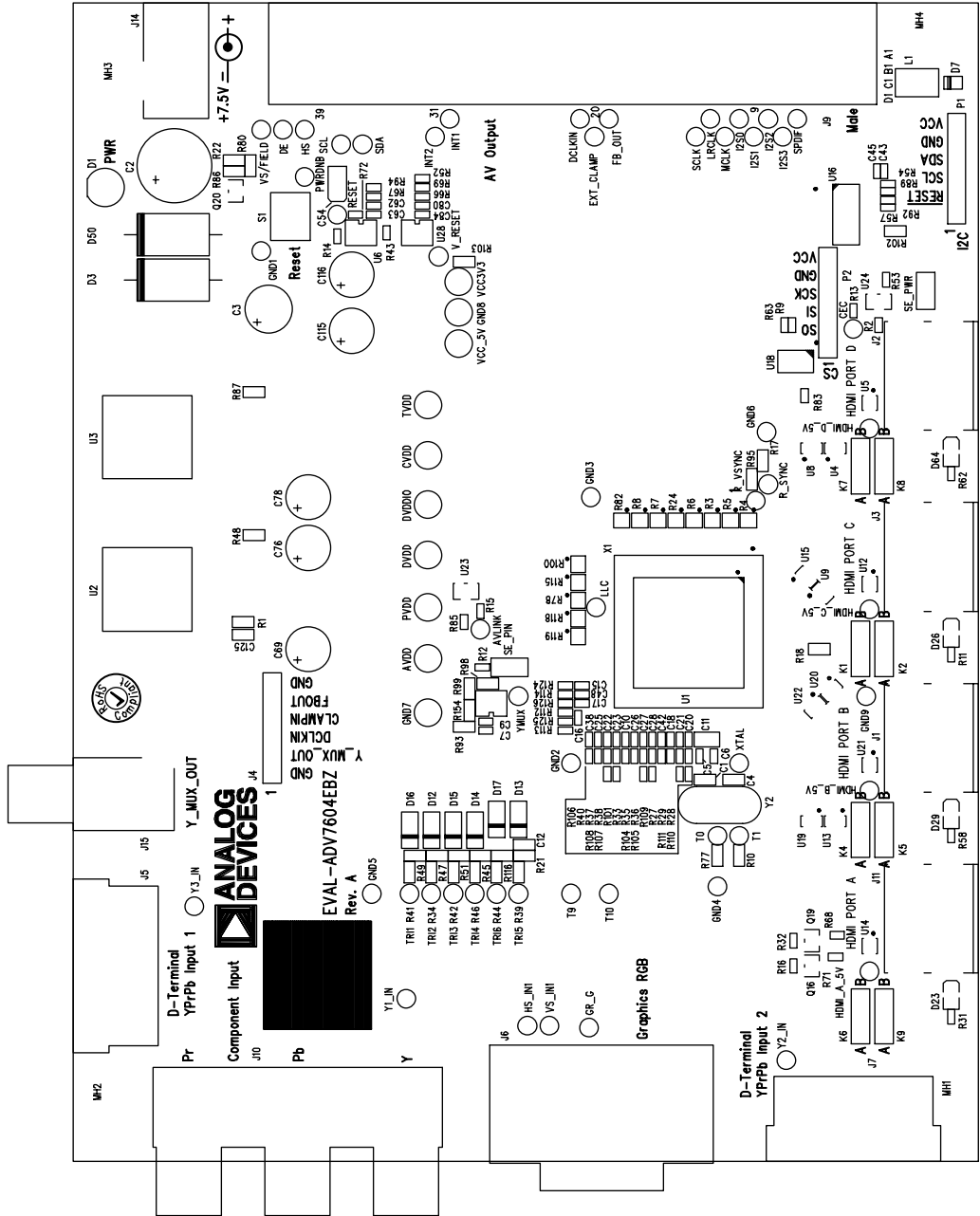

EVAL-ADV7604EBZ Rev. A (Primary Side View) Silkscreen - Primary Side



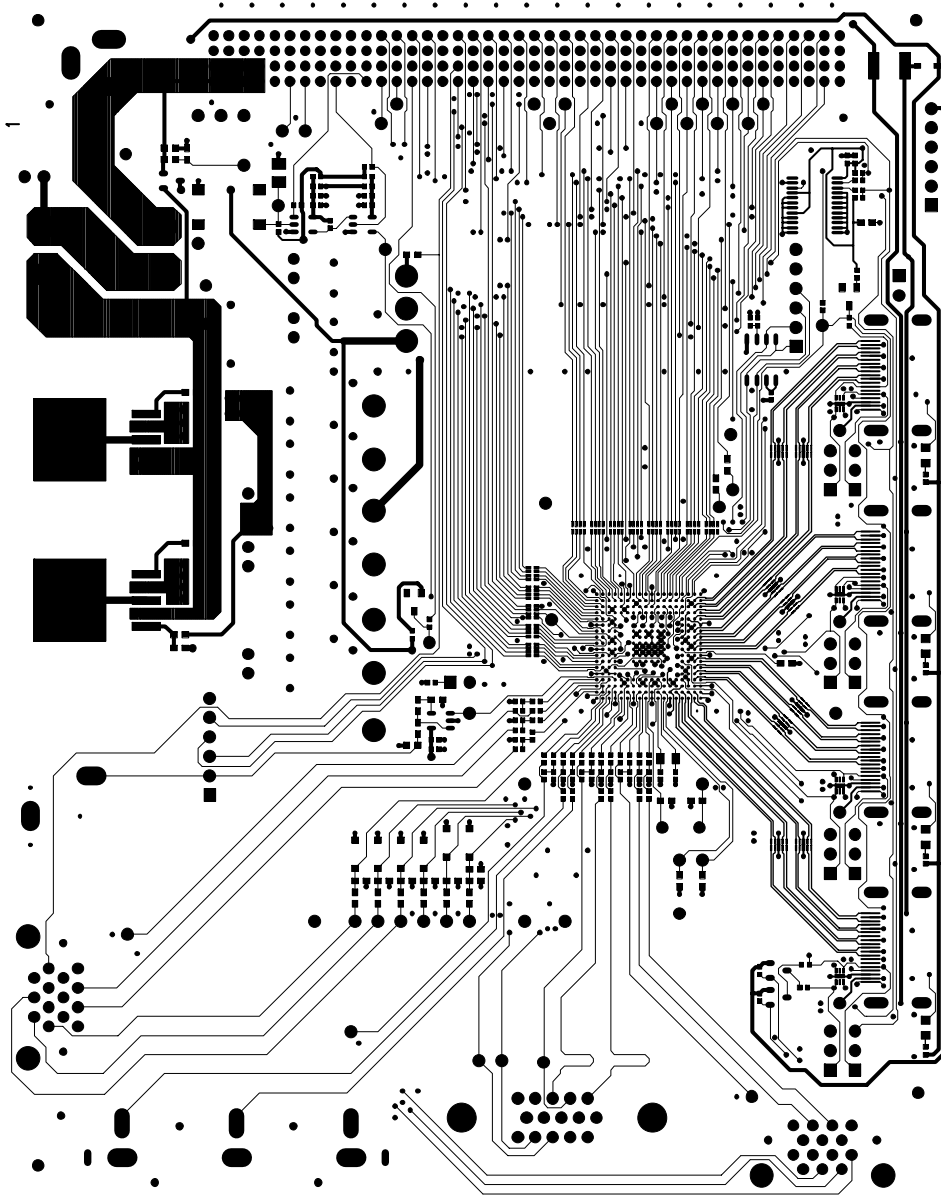
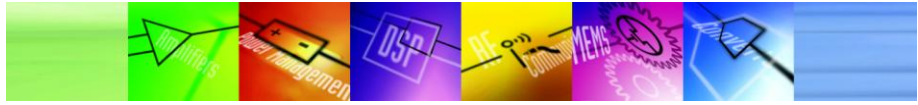

EVAL-ADV7604EBZ Rev. A (Primary Side View) Primary Side - Layer 1



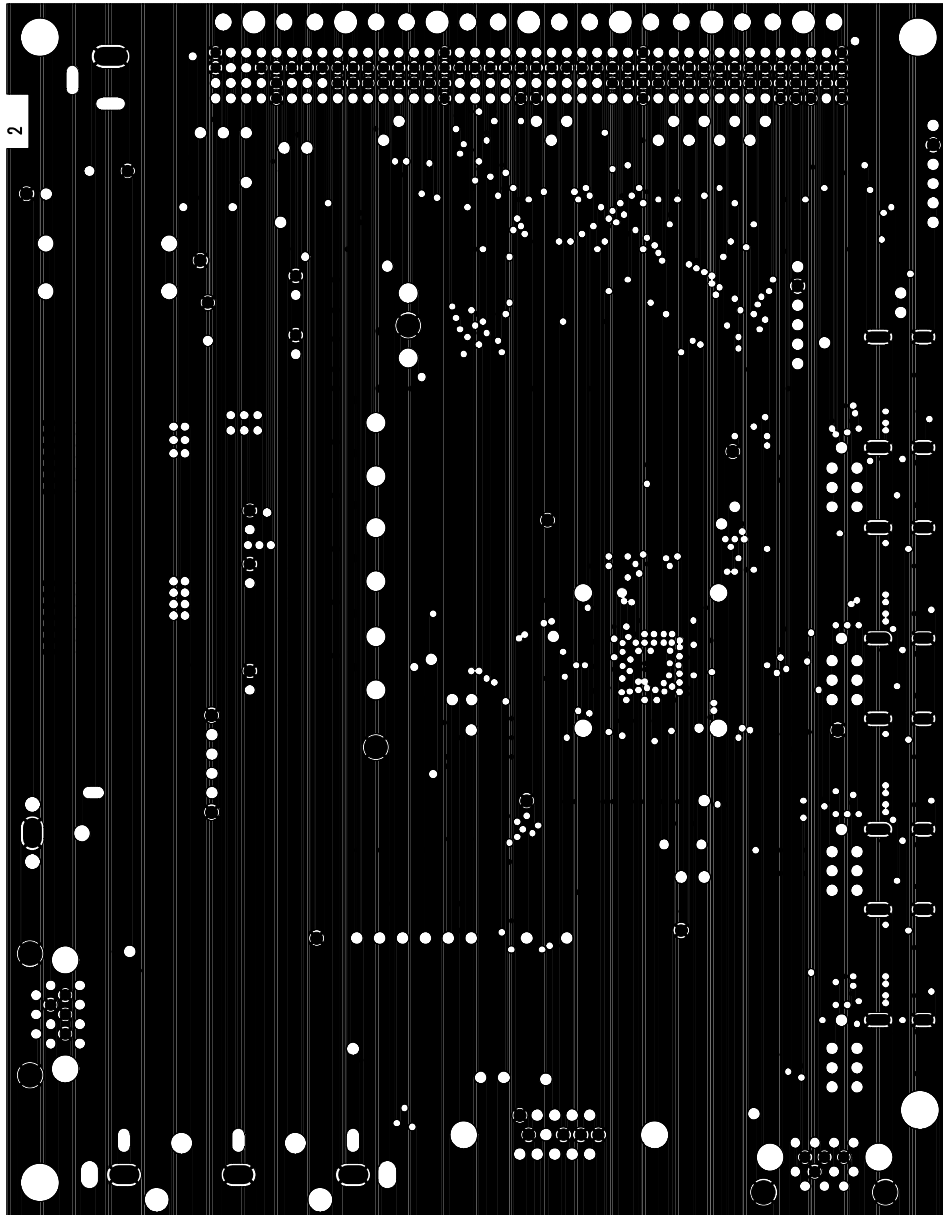
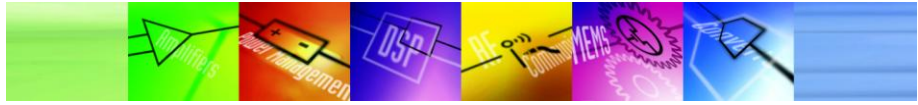

EVAL-ADV7604EBZ Rev. A (Primary Side View) Layer 2 GND



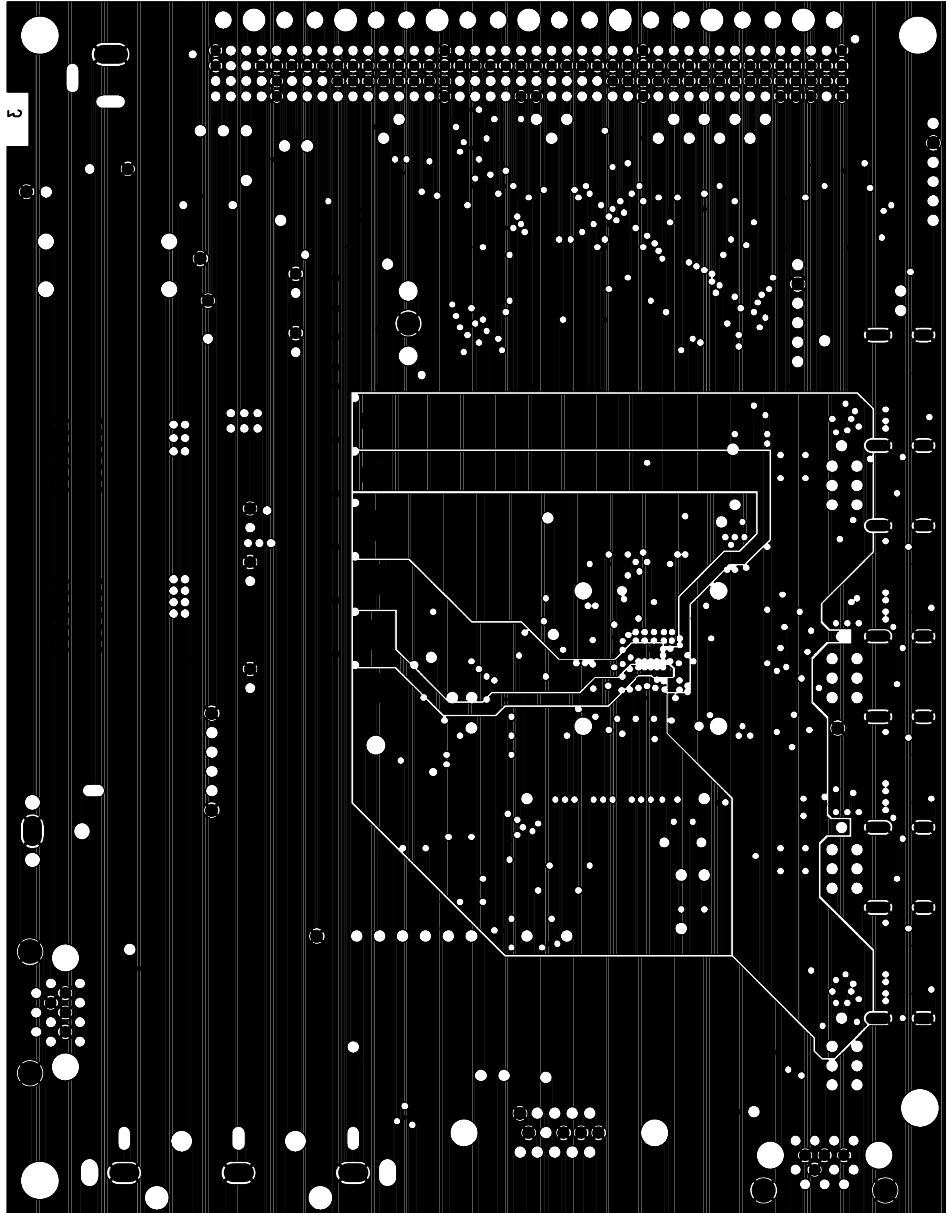

EVAL-ADV7604EBZ Rev. A (Primary Side View) Layer 3 GND1



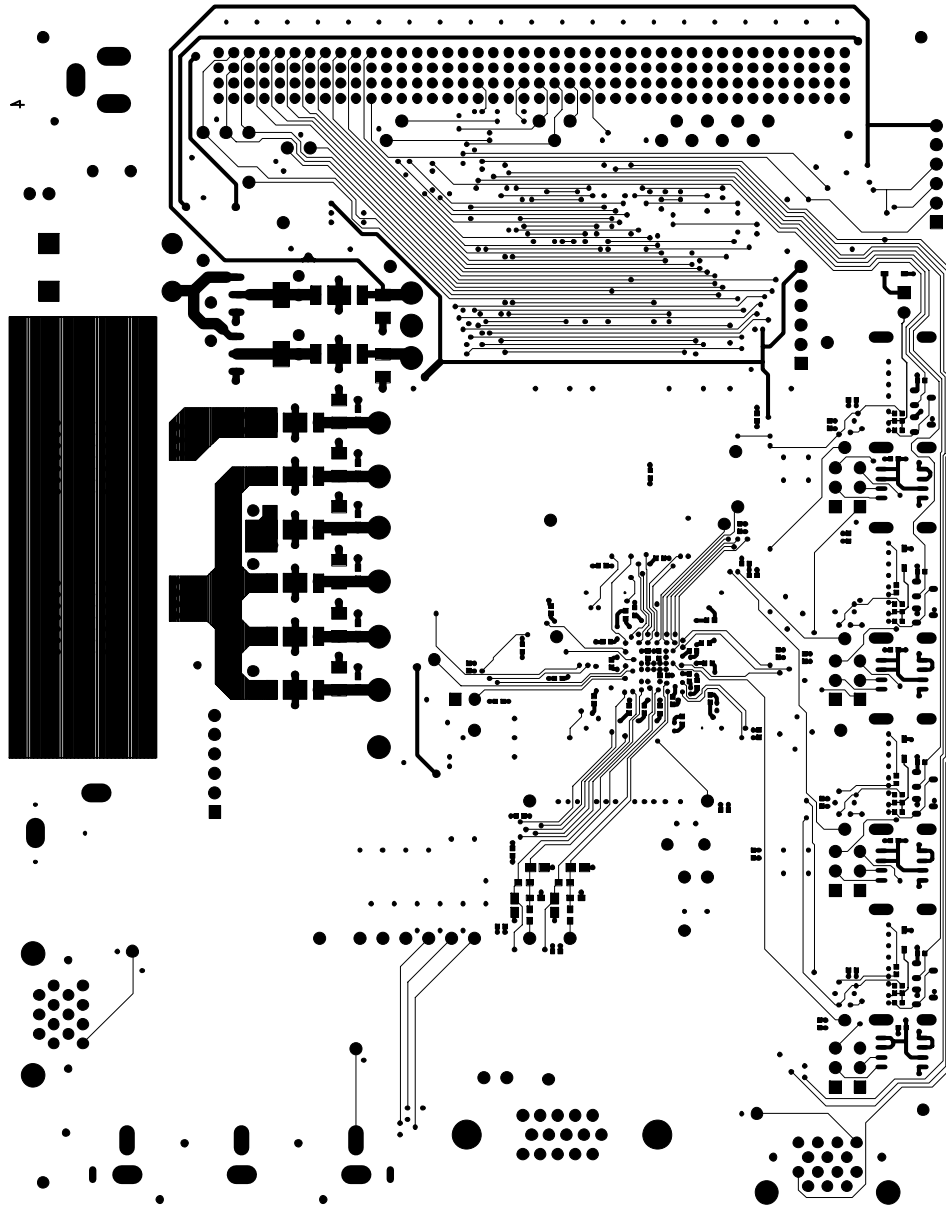

EVAL-ADV7604EBZ Rev. A (Primary Side View) Secondary Side - Layer 4



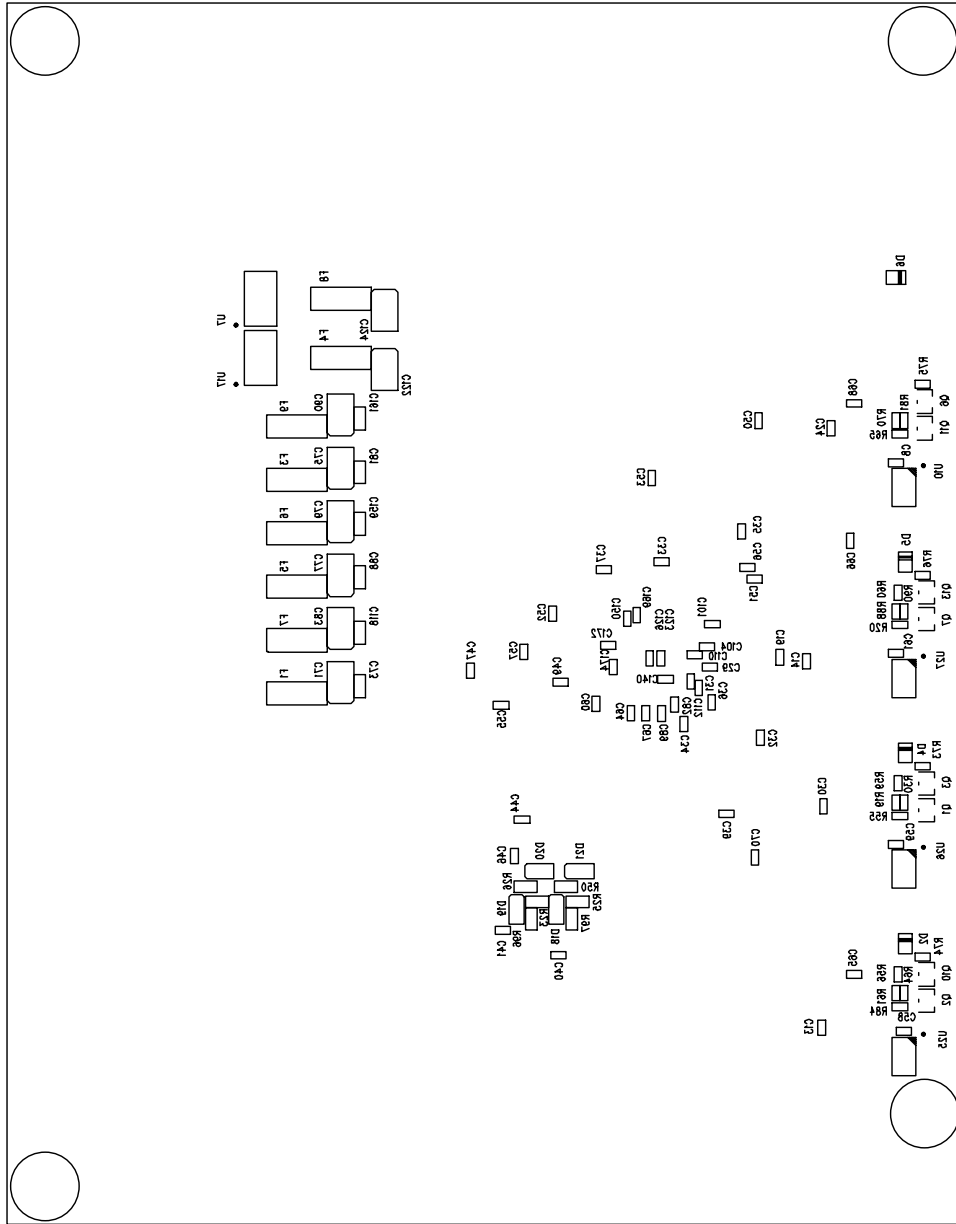
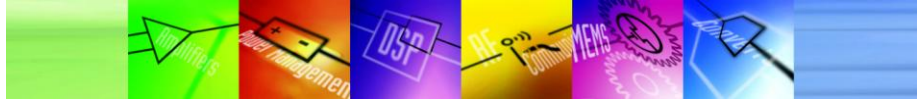

EVAL-ADV7604EBZ Rev. A (Primary Side View) Silkscreen – Secondary Side



X-ON Electronics

Largest Supplier of Electrical and Electronic Components

Click to view similar products for [Video IC Development Tools](#) category:

Click to view products by [Analog Devices](#) manufacturer:

Other Similar products are found below :

[EVAL-ADV7181DEBZ](#) [TW6872-NA1-CR-EVALZ](#) [3202](#) [MAX9268EVKIT+](#) [MAX3815AHDMIEVKIT+](#) [ISL79987-EVAL](#) [ISL59110IEZ-](#)
[EVALZ](#) [LI-USB30-CNTL](#) [P0447](#) [1937](#) [EVAL-ADV7182EBZ](#) [EVAL-ADV7281EBZ](#) [EVAL-ADV7283EBZ](#) [ADZS-DECODE-EX3](#) [EBK-](#)
[GS6080-00](#) [MXOV10635-S32V](#) [OV10640CSP-S32V](#) [1823](#) [EVAL-ADV7391EBZ](#) [EVAL-ADV7280AMEBZ](#) [ME813A-WH50C](#) [EVAL-](#)
[ADV7282AEBZ](#) [ME812AU-WH50R](#) [ME812A-WH50R](#) [EVAL-ADV7182AEBZ](#) [ME813AU-WH50C](#) [EVAL-ADV7282AMEBZ](#) [EVAL-](#)
[ADV7281AMEBZ](#) [LI-TX1-KIT-IMX274CS-T](#) [LI-TX1-KIT-IMX274CS](#) [3508](#) [DEV-14028](#) [VIDEO-DC-MIPI](#) [107391](#) [EVAL-](#)
[ADV7280AEBZ](#) [LF-PNV-EVN](#) [EP-DCOV2735-F36](#) [UP-PACK-VISION-002](#) [3099](#) [3100](#) [3414](#) [3415](#) [397](#) [4248](#) [DC794A](#) [EVAL-](#)
[AD9984AEBZ](#) [EVAL-ADV7180-32EBZ](#) [EVAL-ADV7180LFEBZ](#) [EVAL-ADV7180LQEBZ](#) [EVAL-ADV7181CLQEBZ](#)