

Devices Connected/Referenced

ADuM4160	Full/Low Speed USB Isolator
ADuM1100	Digital Isolator
ADuM5000	Isolated DC-to-DC Converter

Universal Serial Bus (USB) Cable Isolator Circuit

EVALUATION AND DESIGN SUPPORT

Circuit Evaluation Boards

[CN-0159 Circuit Evaluation Board](#)

Design and Integration Files

[Schematics, Layout Files, Bill of Materials](#)

CIRCUIT FUNCTION AND BENEFITS

The universal serial bus (USB) is rapidly becoming the standard interface for most PC peripherals. It is displacing RS-232 and the parallel printer port because of superior speed flexibility and support of device hot swap. There has been a strong desire on the part of industrial and medical equipment manufacturers to use the bus as well, but adoption has been slow because there has not been a good way to provide the isolation required for connections to machines that control dangerous voltages or low leakage defibrillation proof connections in medical applications.

The [ADuM4160](#) is designed primarily as an isolation element for a peripheral USB device. However, there are occasions when it is useful to create an isolated cable function. Several issues must be addressed to use the [ADuM4160](#) for this application. Whereas the buffers on the upstream and downstream sides of the [ADuM4160](#) are the same and capable of driving a USB cable, the downstream buffers must be capable of adjusting speed to a full or low speed peripheral that is connected to it. The upstream connection must act like a peripheral, and the downstream connection must behave like a host.

Unlike the case of building a dedicated peripheral interface where the speed is known and not changed, host applications must adapt to detect whether a low or full speed device has been connected. The [ADuM4160](#) is intended to be hardwired to a single speed via pins; therefore, it works when the peripheral plugged into its downstream side is the correct speed, but it fails when the wrong speed peripheral is attached. The best way to address this is to combine the [ADuM4160](#) with a hub controller.

The upstream side of a hub controller can be thought of as a standard fixed speed peripheral port that can be easily isolated with the [ADuM4160](#), whereas the downstream ports are all handled by the hub controller. However, in many cases, while it is not certifiable as fully USB compliant, a single speed cable is acceptable from a practical standpoint, especially if custom connectors are used so that it cannot be confused with a compliant device. The hub chip can be eliminated, and the design becomes very small and simple.

The [ADuM4160](#) provides an inexpensive and easy way to implement an isolation buffer for medical and industrial peripherals. The challenge that must be met is to use this to create a bus-powered cable isolator by pairing the [ADuM4160](#) with a small isolated dc-to-dc converter such as the [ADuM5000](#). As with isolating any device, the services that the [ADuM4160](#) provides are as follows:

1. Directly isolates, in the upstream, the USB D+ and D- lines of a cable.
2. Implements an automatic scheme for data flow of control that does not require external control lines.
3. Provides medical grade isolation.
4. Supports full speed or low speed signaling rates.
5. Supports isolated power delivery through the cable.

The goal of the application circuit shown in Figure 1 is to isolate a peripheral device that already implements a USB interface. It is not possible to make a fully compliant bus-powered cable because there are no 100% efficient power converters to transfer the bus voltage across the barrier. In addition, the quiescent current of the converter does not comply with the standby current requirements of the USB standard. This is all in addition to the speed detection limitations of the [ADuM4160](#). What can be achieved is a fixed speed or switch-controlled speed cable that can supply a modest power to the downstream peripheral. However, it is a custom application that is not completely compliant with the USB standard.

Rev. A

Circuits from the Lab™ circuits from Analog Devices have been designed and built by Analog Devices engineers. Standard engineering practices have been employed in the design and construction of each circuit, and their function and performance have been tested and verified in a lab environment at room temperature. However, you are solely responsible for testing the circuit and determining its suitability and applicability for your use and application. Accordingly, in no event shall Analog Devices be liable for direct, indirect, special, incidental, consequential or punitive damages due to any cause whatsoever connected to the use of any Circuits from the Lab circuits. (Continued on last page)

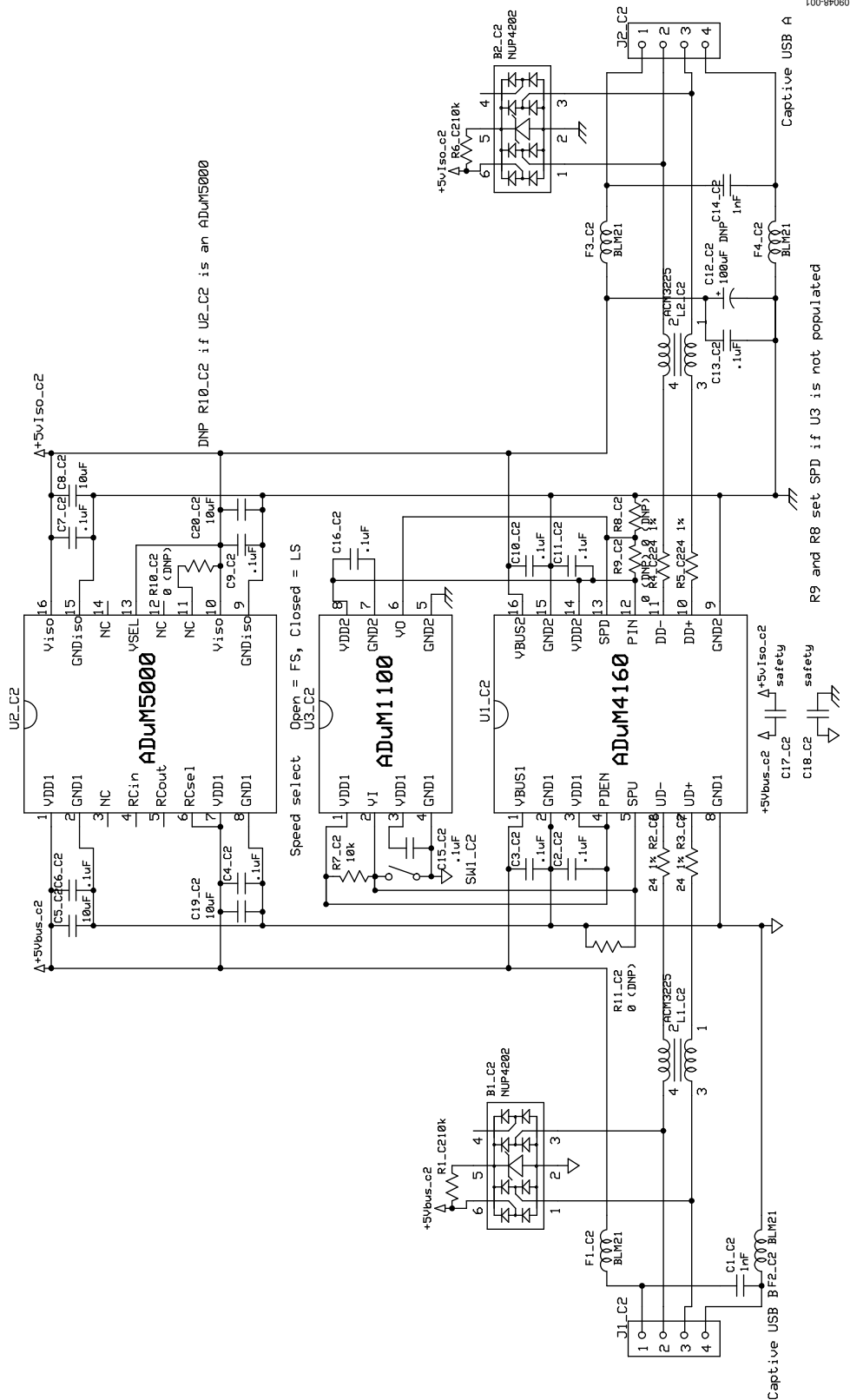

Figure 1. USB Cable Isolator Circuit

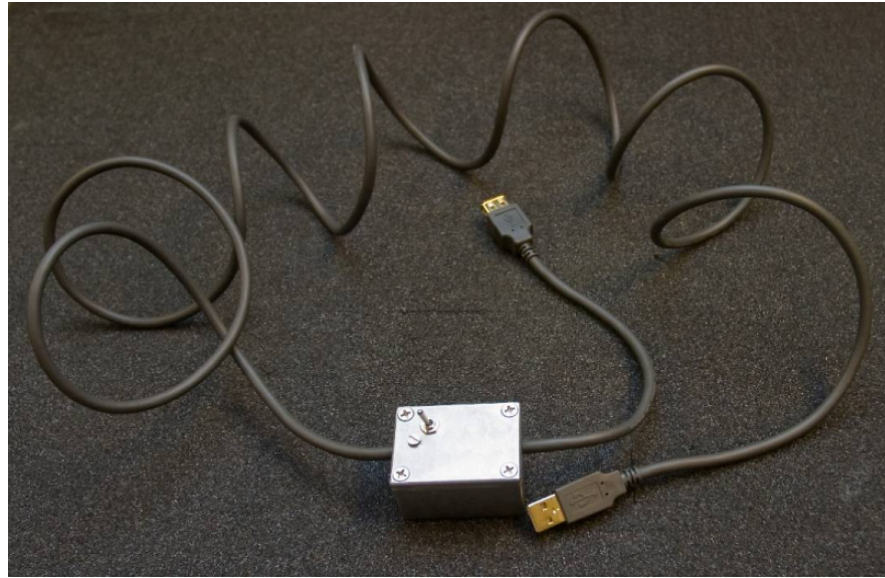

Figure 2. Isolated Cable Box

CIRCUIT DESCRIPTION

Power for the upstream USB connector is derived from the 5 V VBUS voltage available on the USB cable. The bus voltage also drives an **ADuM5000**, which is used to create a VBUS2 voltage for the downstream side of the **ADuM4160** with up to 100 mA of power for the peripheral. The **ADuM5000** was chosen for its high isolation voltage and small form factor. It provides sufficient power to operate small bus-powered devices such as a mouse, keyboard, and memory stick. Because this component uses chip-scale micro transformers, the internal switching frequencies are very high, and designs must be able to minimize radiated emissions by using ferrite beads on the cable well and following recommendations referred to in the [AN-0971 Application Note](#). Specific layout, decoupling, and grounding techniques must be employed to pass system EMI/RFI tests. See [Tutorial MT-031](#) and [Tutorial MT-101](#) for guidance. Complete layout and Gerber files are available for the **ADuM4160** USB cable isolation board at <http://www.analog.com/CN0159-DesignSupport>.

The **ADuM4160** isolated cable application has several options for power, bus speed, and ESD/EOS protection that must be determined. Peripheral devices run at one of three speeds, low (1.5 Mbps), full (12 Mbps), and high (480 Mbps). The **ADuM4160** does not support high speed operation and blocks handshaking signals that are used to negotiate that speed. High speed mode starts as a full speed configuration; the peripheral requests high speed support through a process called a high speed chirp. The **ADuM4160** ignores the high speed chirp; therefore, the request for high speed operation is never passed to the host, and the peripheral automatically continues to work at full speed. This application includes a switch and a single channel isolator that allows the user to select a cable speed of full or low by setting the SPU and SPD pins. This feature is optional if single speed operation is adequate.

Power is provided through the VBUSx pins. The 3.3 V signaling voltage is created by internal 3.3 V regulators at the VDDx pin. The **ADuM4160** supports other power configurations that are examined in other circuit notes. In the circuit shown in Figure 1, both the upstream and downstream sides of the **ADuM4160** are set to derive power from the VBUSx lines and the internal regulators.

The **ADuM4160** has an option to delay application of the upstream pull-up under control of the peripheral. This function is controlled by the PIN input. In this application, the PIN input is shorted high so that the upstream pull-up is applied as soon as peripheral power is applied.

Protection devices are used in this circuit. These were chosen from manufacturers that have a wide variety of components available; the particular components were chosen to allow them to be replaced by 0 Ω shorts, removing them from the circuit. The choice of protection should be reviewed by the designer and can range anywhere from not needing external protection to needing a full complement of transient suppressors and filter elements. The circuit elements included in this application show what type of protection can be used.

When the circuit is functioning, packets are detected and data is shuttled from one side of the isolation barrier to the other. Data shown in Figure 3 and Figure 4 show a typical full speed transaction both as time domain data and as an eye diagram. Features to note in the real-time data are the passive idle state at the start of the packet, which transitions to a driven J, and then the end of packet at the end of the transaction that shows as a single-ended zero state followed by an idle J. It is the automatic flow of control and the handling of these special logic states that make the **ADuM4160** chip possible and unique in the marketplace.

The cable design is fully isolated from the upstream data connection for transients up to 2.5 kV. Future *isoPower*® modules will enable full medical 5 kV isolation of cables. The downstream port is powered by the upstream VBUS1 line. This limits the available power to the application to 500 mA at 5 V, the maximum power available to a standard USB port. This is adequate to run the ADuM5000 with a 100 mA external load. Low, full, and high speed peripherals can be connected to the downstream ports, but the cable must be manually changed between full speed and low speed modes. The design relies on the internal short circuit protection of the ADuM5000 for safety.

The data shown in Figure 3 and Figure 4 are generated as part of the USB-IF qualification process. Figure 3 shows a test data packet from the ADuM4160 upstream port to the host. Areas to note are the leading idle state where the passive resistor network holds an idle J state. The center of the packet is a mix of J and K states. The right side of the packet is an EOP (end of packet) marker, which is a single-ended 0 followed by a driven J, which transitions to an idle J.

Upstream Full Speed Signal Quality Test Reference: USB 2.0 Specification, Section 7.1.11., Section 7.1.2.1. Upstream Full Speed Rise Time Test Reference: USB 2.0 Specification, Section 7.1.11., Section 7.1.2.2. Upstream Full Speed Fall Time Test Reference: USB 2.0 Specification, Section 7.1.11., Section 7.1.2.2.

Figure 3 is a full speed eye diagram showing that the ADuM4160 provides an adequate open eye, staying well out of the keep out region. Similar data is taken for low speed evaluation as well.

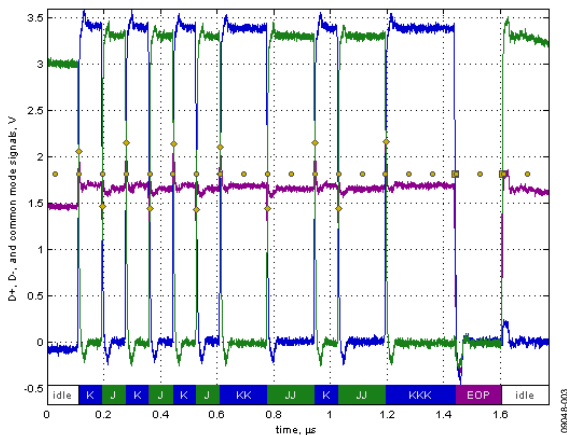

Figure 3. Full Speed Test Packet Traffic Driven by the Upstream ADuM4160 Port

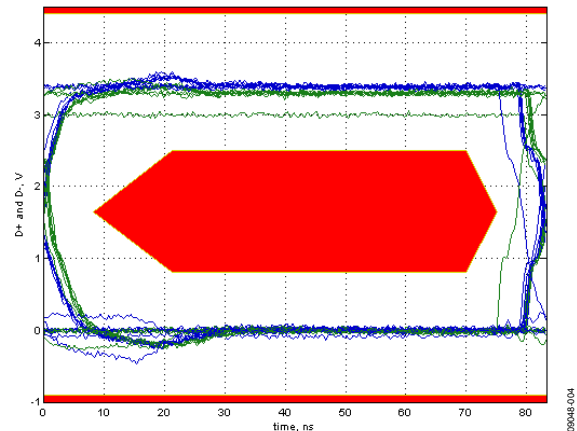

Figure 4. Full Speed Eye Diagram Showing the Exclusion Zone

A complete design support package for this circuit note can be found at <http://www.analog.com/CN0159-DesignSupport>.

CIRCUIT EVALUATION AND TEST

Circuit note CN-0159 uses the CN0159 USB Cable Isolator Circuit Board, specifically developed to evaluate and test the circuit described in the note. A detailed schematic of the circuit is contained in Figure 1.

Equipment Needed

A USB data port connection with an upstream-downstream data path, the CN0159 Universal Serial Bus (USB) Cable Isolator Circuit Board or equivalent board, two USB cables, and a high speed digital oscilloscope.

Getting Started

Circuit note CN-0159 contains a description of the circuit, a circuit schematic, and a schematic of the test setup. It describes how to perform the testing and obtain the data. Details regarding the CN-0159 USB Cable Isolator Circuit Board, including Gerbers, bill of materials, and other information, is available at <http://www.analog.com/CN0159-DesignSupport>. Information regarding the isolator components used in the circuit can be found in the ADuM1100, the ADuM4160, and the ADuM5000 data sheets; the ADuM4160 evaluation board user guide UG-043, and the evaluation board user guide for the 16-lead SOIC and 16-lead QSOP digital isolators, UG-042.

Functional Block Diagram

See Circuit Description section for the schematic and information regarding the described test setup.

LEARN MORE

- CN0159 Design Support Package:
<http://www.analog.com/CN0159-DesignSupport>
- Cantrell, Mark. Application Note AN-0971, *Recommendations for Control of Radiated Emissions with isoPower Devices*. Analog Devices.
- Chen, Baoxing, John Wynne, and Ronn Kliger. *High Speed Digital Isolators Using Microscale On-Chip Transformers*, Analog Devices, 2003.
- Chen, Baoxing. *iCoupler® Products with isoPower™ Technology: Signal and Power Transfer Across Isolation Barrier Using Microtransformers*, Analog Devices, 2006
- Chen, Baoxing. "Microtransformer Isolation Benefits Digital Control." *Power Electronics Technology*. October 2008.
- Krakauer, David. "Digital Isolation Offers Compact, Low-Cost Solutions to Challenging Design Problems." *Analog Dialogue*. Volume 40, December 2006.
- MT-031 Tutorial, *Grounding Data Converters and Solving the Mystery of "AGND" and "DGND"*, Analog Devices.
- MT-101 Tutorial, *Decoupling Techniques*, Analog Devices.
- USB 2.0 Specifications, USB Implementers Forum, Inc.
- Wayne, Scott. "iCoupler® Digital Isolators Protect RS-232, RS-485, and CAN Buses in Industrial, Instrumentation, and Computer Applications." *Analog Dialogue*. Volume 39, October 2005.

Data Sheets and Evaluation Boards

- ADuM4160 Data Sheet
- ADuM4160 Evaluation Board
- ADuM1100 Data Sheet
- ADuM1100 Evaluation Board
- ADuM5000 Data Sheet
- ADuM5000 Evaluation Board

REVISION HISTORY**11/10—Rev. 0 to Rev. A**

Added Evaluation and Design Support Section.....	1
Changes to Circuit Description Section.....	3
Added Circuit Evaluation and Test Section.....	4

7/10—Revision 0: Initial Version

(Continued from first page) Circuits from the Lab circuits are intended only for use with Analog Devices products and are the intellectual property of Analog Devices or its licensors. While you may use the Circuits from the Lab circuits in the design of your product, no other license is granted by implication or otherwise under any patents or other intellectual property by application or use of the Circuits from the Lab circuits. Information furnished by Analog Devices is believed to be accurate and reliable. However, Circuits from the Lab circuits are supplied "as is" and without warranties of any kind, express, implied, or statutory including, but not limited to, any implied warranty of merchantability, noninfringement or fitness for a particular purpose and no responsibility is assumed by Analog Devices for their use, nor for any infringements of patents or other rights of third parties that may result from their use. Analog Devices reserves the right to change any Circuits from the Lab circuits at any time without notice but is under no obligation to do so.

X-ON Electronics

Largest Supplier of Electrical and Electronic Components

Click to view similar products for [Interface Development Tools](#) category:

Click to view products by [Analog Devices](#) manufacturer:

Other Similar products are found below :

[DP130SSEVM](#) [ISO3086TEVM-436](#) [ADP5585CP-EVALZ](#) [CHA2066-99F](#) [AS8650-DB](#) [MLX80104 TESTINTERFACE](#) [I2C-CPEV/NOPB](#)
[ISO35TEVM-434](#) [416100120-3](#) [XR18910ILEVB](#) [XR21B1421IL28-0A-EVB](#) [EVAL-ADM2491EEBZ](#) [MAXREFDES23DB#](#)
[MAX9286COAXEVKIT#](#) [MAX3100EVKIT](#) [MAX13235EEVKIT](#) [MAX14970EVKIT#](#) [XR21B1424IV64-0A-EVB](#) [CMOD232+](#)
[MAX13042EEVKIT+](#) [MAX14838EVKIT#](#) [MAXCAM705OV635AAA#](#) [MAX9205EVKIT](#) [DS100BR111AEVK/NOPB](#) [DC241C](#)
[MAX9286RCARH3DB#](#) [MAX13035EEVKIT+](#) [DC1794A](#) [SN65HVS885EVM](#) [EVB81112-A1](#) [DFR0257](#) [ZLR964122L](#) [ZLR88822L](#)
[DC196A-B](#) [DC196A-A](#) [DC327A](#) [OM13585UL](#) [MAX16972AGEEVKIT#](#) [MARS1-DEMO3-ADAPTER-GEVB](#) [MAX7315EVKIT+](#) [PIM511](#)
[PIM536](#) [PIM517](#) [DEV-17512](#) [STR-FUSB3307MPX-PPS-GEVK](#) [MAXREFDES177#](#) [EVAL-ADM2567EEBZ](#) [EVAL-ADN4654EBZ](#)
[MAX9275COAXEVKIT#](#) [MAX2202XEVKIT#](#)