

Circuits from the Lab[®]
Reference Designs

Circuits from the Lab[®] reference designs are engineered and tested for quick and easy system integration to help solve today's analog, mixed-signal, and RF design challenges. For more information and/or support, visit www.analog.com/CN0288.

Devices Connected/Referenced

AD598	LVDT Signal Conditioner
AD8615	Precision, 20 MHz, CMOS, Single RRIO Operational Amplifier
AD7992	2-Channel, 12-Bit ADC with I ² C Compatible Interface in 10-lead MSOP

LVDT Signal Conditioning Circuit

EVALUATION AND DESIGN SUPPORT

Circuit Evaluation Boards

[CN-0288 Circuit Evaluation Board \(EVAL-CN0288-SDP\)](#)
[System Demonstration Platform \(EVAL-SDP-CB1Z\)](#)

Design and Integration Files

[Schematics](#), [Layout Files](#), [Bill of Materials](#)

CIRCUIT FUNCTION AND BENEFITS

The circuit shown in Figure 1 is a complete adjustment-free linear variable differential transformer (LVDT) signal conditioning circuit. This circuit can accurately measure linear displacement (position).

The LVDT is a highly reliable sensor because the magnetic core can move without friction and does not touch the inside of the tube. Therefore, LVDTs are suitable for flight control feedback systems, position feedback in servomechanisms, automated measurement in machine tools, and many other industrial and scientific electromechanical applications where long term reliability is important.

This circuit uses the AD598 LVDT signal conditioner that contains a sine wave oscillator and a power amplifier to generate the excitation signals that drive the primary side of the LVDT. The AD598 also converts the secondary output into a dc voltage. The AD8615 rail-to-rail amplifier buffers the output of the AD598 and drives a low power 12-bit successive approximation analog-to-digital converter (ADC). The system has a dynamic range of 82 dB and a system bandwidth of 250 Hz, making it ideal for precision industrial position and gauging applications.

The signal conditioning circuitry of the system consumes only 15 mA of current from the ± 15 V supply and 3 mA from the +5 V supply, making this ideal for remote applications. The circuit can operate a remote LVDT from up to 300 feet away, and the output can drive up to 1000 feet.

This circuit note discusses basic LVDT theory of operation and the design steps used to optimize the circuit shown in Figure 1 for a chosen bandwidth, including noise analysis and component selection considerations.

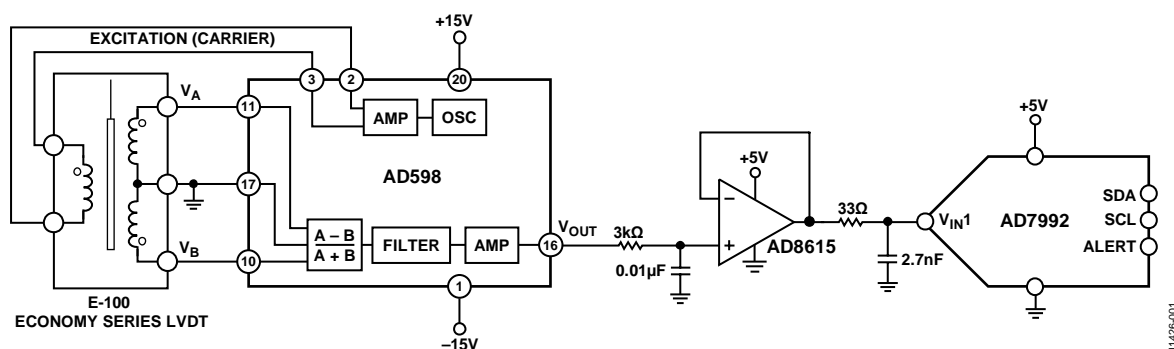

Figure 1. LVDT Signal Conditioning Circuit (Simplified Schematic: All Connections and Decoupling Not Shown)

Rev. A

Circuits from the Lab[™] circuits from Analog Devices have been designed and built by Analog Devices engineers. Standard engineering practices have been employed in the design and construction of each circuit, and their function and performance have been tested and verified in a lab environment at room temperature. However, you are solely responsible for testing the circuit and determining its suitability and applicability for your use and application. Accordingly, in no event shall Analog Devices be liable for direct, indirect, special, incidental, consequential or punitive damages due to any cause whatsoever connected to the use of any Circuits from the Lab circuits. (Continued on last page)

CIRCUIT DESCRIPTION

Theory of Operation

An LVDT is an absolute displacement transducer that converts a linear displacement or position from a mechanical reference (or zero) into a proportional electrical signal containing phase (for direction) and amplitude information (for distance). The LVDT operation does not require electrical contact between the moving part (probe or core rod assembly) and the transformer. Instead, it relies on electromagnetic coupling. For this reason, and because they operate without any built-in electronic circuitry, LVDTs are widely used in applications where long life and high reliability under severe environments are a required, such military and aerospace applications.

For this circuit, the E-100 Economy Series LVDT sensor from Measurement Specialties™, Inc. was used with the [AD598](#). With a linearity of $\pm 0.5\%$ of full range, the E Series is suitable for most applications with moderate operation temperature environments.

The [AD598](#) is a complete, LVDT signal conditioning subsystem. It converts the transducer mechanical position of LVDTs to a unipolar dc voltage with a high degree of accuracy and repeatability. All circuit functions are included on the chip. With the addition of a few external passives components to set frequency and gain, the [AD598](#) converts the raw LVDT secondary output to a scaled dc signal.

The [AD598](#) contains a low distortion sine wave oscillator to drive the LVDT primary. The frequency of the sine wave is determined by a single capacitor and can range from 20 Hz to 20 kHz with amplitudes from 2 V rms to 20 V rms.

The LVDT secondary output consists of two sine waves that drive the [AD598](#) directly. The [AD598](#) operates upon the two signals, dividing their difference by their sum and producing a scaled unipolar dc output. Previous LVDT conditioners synchronously detect this amplitude difference and convert its absolute value to a voltage proportional to position. This technique uses the primary excitation voltage as a phase reference to determine the polarity of the output voltage. There are a number of problems associated with this technique. They include:

- Producing a constant amplitude, constant frequency excitation signal
- Compensating for LVDT primary to secondary phase shifts
- Compensating for these shifts as a function of temperature and frequency

The [AD598](#) eliminates all of these problems. The [AD598](#) does not require a constant amplitude because it works on the ratio of the difference and sum of the LVDT output signals. A constant frequency signal is not necessary because the inputs are rectified and only the sine wave carrier magnitude is processed. There is no sensitivity to phase shift between the primary and the LVDT outputs because synchronous detection is not employed.

The ratiometric principle upon which the [AD598](#) operates requires that the sum of the LVDT secondary voltages remains constant with LVDT stroke length. Although LVDT manufacturers generally do not specify the relationship between $V_A + V_B$ and stroke length, it is recognized that some LVDTs do not meet this requirement. In these cases, a nonlinearity results. However, the majority of available LVDTs do in fact meet these requirements.

Component Selection

The design procedure for the dual supply operation (± 15 V) found in the [AD598](#) data sheet was followed to set the excitation frequency to 2.5 kHz, system bandwidth to 250 Hz, and an output voltage from 0 V to 5 V.

It is normal for the [AD598](#) internal oscillator to produce a small amount of ripple that feeds through to the output. A passive low-pass filter is used to reduce this ripple to the required level.

When selecting capacitor values to set the bandwidth of the system, a trade-off is involved. Choosing smaller capacitors give higher system bandwidth but increase the amount of output voltage ripple. The ripple can be reduced by increasing the shunt capacitance across the feedback resistor used to set the output voltage level; however, this also increases phase lag.

The [AD8615](#) operational amplifier buffers the output of the [AD598](#), which ensures that the [AD7992](#) ADC is driven by a low impedance source (high source impedances significantly affect the ac performance of the ADC).

The low-pass filter between the output of the [AD598](#) and the input of the [AD8615](#) serves two purposes:

- It limits the input current to the [AD8615](#)
- It filters the output voltage ripple.

The [AD8615](#) has internal protective circuitry that allows voltages exceeding the supply to be applied at the input. This is important because the output voltage of the [AD598](#) can swing ± 11 V with ± 15 V supplies. As long as the input current is limited to less than 5 mA, higher voltages can be applied to the input. This is primarily due to the extremely low input bias current of the [AD8615](#) (1 pA) which allows the use of larger resistors. The use of these resistors adds thermal noise, which contributes to the overall output voltage noise of the amplifier.

The [AD8615](#) is an ideal amplifier to buffer and drive the input of the [AD7992](#) 12-bit SAR ADC because of its input overvoltage protection, and its ability to swing rail-to-rail at both the input and output.

Noise Analysis

With all signal condition components selected, the amount of resolution needed to convert the signal must be determined. As in most noise analyses, only the key contributors need to be identified. Noise sources combine in an rss manner; therefore, any single noise source that is at least three-to-four times larger than any of the others dominates.

In the case of the LVDT signal conditioning circuit, the dominant source of the output noise is the output ripple of the AD598. The other sources of noise (resistor noise, input voltage noise, and output voltage noise of the AD8615) are significantly smaller in comparison.

The output voltage ripple of the AD598 is 0.4 mV rms with a 0.39 μF capacitor value and with a 10 nF shunt capacitor across the feedback resistor shown in Figure 2. Note that these components and related pin connections are not shown in the simplified schematic in Figure 1; however, details can be found in the AD598 data sheet.

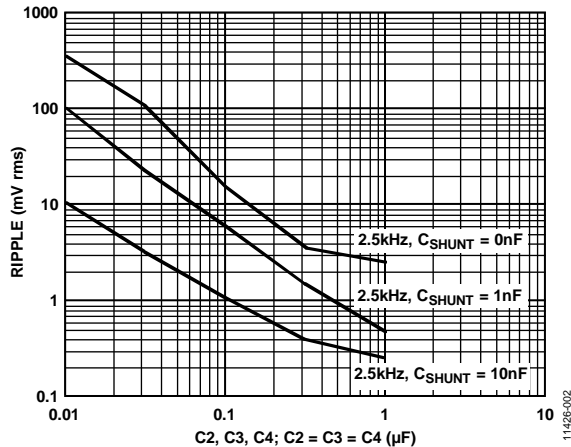

Figure 2. Output Voltage Ripple vs. Filter Capacitance

The maximum number of rms counts that can be resolved can now be calculated by dividing the full-scale output by the total system rms noise.

$$\text{Total RMS Counts} = 5 \text{ V} / 0.4 \text{ mV} = 12,500$$

The effective resolution is found by taking the base 2 logarithm of the total rms counts.

$$\text{Effective Resolution} = \log_2(12,500) = 13.6 \text{ Bits}$$

Noise-free code resolution can be obtained by subtracting 2.7 bits from the effective resolution.

$$\begin{aligned} \text{Noise-Free Code Resolution} &= \text{Effective Resolution} - 2.7 \text{ Bits} \\ &= 13.6 \text{ Bits} - 2.7 \text{ Bits} \\ &= 10.9 \text{ Bits} \end{aligned}$$

The total output dynamic range of the system can be calculated by dividing the full-scale output signal (5 V) by the total output rms noise (0.4 mV rms) and converting it to decibels, yielding approximately 82 dB.

$$\text{Dynamic Range} = 20 \log(5 \text{ V} / 0.4 \text{ mV}) = 82 \text{ dB}$$

The AD7992 is a good candidate for this application because it has 12-bit resolution and a sampling rate of 188 kSPS per channel when used with a 3.4 MHz serial clock.

Test Results

Using a Measurement Specialties, Inc. E-100 Economy Series LVDT connected to J3 and using a digital oscilloscope to monitor the output of the AD598 found on J6 on the EVAL-CN0288-SDPZ evaluation board, the actual output ripple found was 6.6 mV p-p, as is shown in Figure 3.

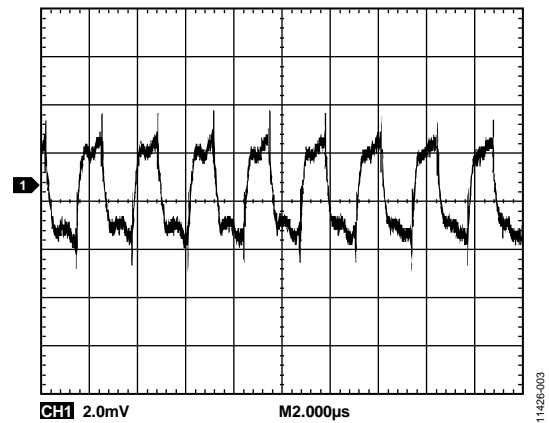

Figure 3. Output Voltage Ripple Before Low-Pass Filter

The low-pass filter (3 kΩ, 0.01 μF) between the AD598 output and the AD8615 input has a -3 dB bandwidth of 5.3 kHz and reduces the ripple to 2 mV p-p.

With the low-pass filter installed between the output stage of the AD598 and the input stage of the AD8615, data was collected from the EVAL-CN0288-SDPZ evaluation board, as shown in Figure 4.

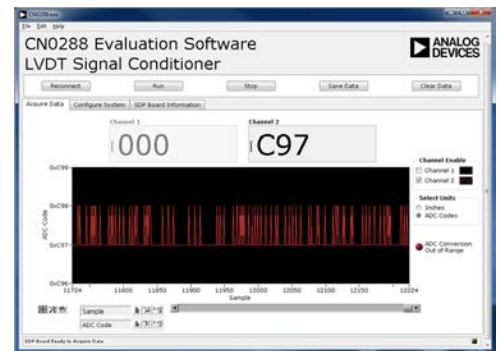

Figure 4. Screenshot of the CN-0288 Evaluation Software

The ripple from the AD598 was attenuated to 2 mV p-p, and the system was able to achieve 11 bits of noise-free code resolution.

A complete design support package for this circuit note can be found at <http://www.analog.com/CN0288-DesignSupport>.

Applications in Flight Control Surface Position Feedback

Unmanned autonomous vehicles (UAVs), or drones, are playing an ever-increasing part in the national security of the United States. These high technology, complex aerial platforms are controlled by a crew miles away and are multimission capable. They include roles such as aerial reconnaissance, combat weapons platforms, battlefield theater command and control oversight, or unmanned in-flight refueling station.

The complex systems employed on UAVs use a myriad of electronic sensors for precise control and feedback. To control the altitude (pitch, roll, and yaw) of the UAV, actuators are used to exert forces on the flight control surfaces. The precise measurement of the position of these actuators is crucial in maintaining the proper flight of path.

The sensors used to measure actuator position need to meet three essential criteria: high accuracy, high reliability, and light weight. All three of these attributes are found in the LVDTs designed by Measurement Specialties, Inc.

Synchronous Operation of Multiple LVDTs

In many applications, such as multiple gaging measurement, a large number of LVDTs are used in close proximity. If these LVDTs operate at similar carrier frequencies, stray magnetic coupling can cause beat notes to be generated. The resulting beat notes may interfere with the accuracy of measurements made under these conditions. To avoid this situation, all LVDTs operate synchronously.

The [EVAL-CN0288-SDPZ](#) evaluation board can be configured to have one master oscillator between two LVDTs by populating Jumper JP1, JP2, and JP4 with a shorting jumper and leaving JP3 unpopulated. Each LVDT primary is driven from its own power amplifier, and, thus, the thermal load is shared between the [AD598s](#).

COMMON VARIATIONS

The components selected were optimized for a maximum 5 V unipolar output from the [AD598](#); however, other combinations can be substituted.

Other suitable single-supply amplifiers are the [AD8565](#) and [AD8601](#). These amplifiers are suitable replacements for the [AD8615](#) because they have input overvoltage protection and the ability to swing rail-to-rail at both the input and output. If dual-supply operation is required, the [ADA4638-1](#) or [ADA4627-1](#) is suggested.

If the [AD598](#) outputs ± 10 V bipolar signals, the [AD7321](#) is suggested. The [AD7321](#) is a 2-channel, bipolar input, 12-bit ADC that can accept true bipolar analog input signals as large as ± 10 V.

CIRCUIT EVALUATION AND TEST

This circuit uses the [EVAL-CN0288-SDPZ](#) circuit board and the [EVAL-SDP-CB1Z](#) SDP-B system demonstration platform controller board. The two boards have 120-pin mating connectors, allowing for the quick setup and evaluation of the performance of the circuit. The [EVAL-CN0288-SDPZ](#) contains the circuit to be evaluated, and the [EVAL-SDP-CB1Z](#) (SDP-B) is used with the [CN-0288 evaluation software](#) to capture the data from the [EVAL-CN0288-SDPZ](#).

Equipment Needed

The following equipment is needed:

- A PC with a USB port and Windows® XP (32 bit), Windows Vista®, or Windows 7
- The [EVAL-CN0288-SDPZ](#) circuit board
- The [EVAL-SDP-CB1Z](#) SDP-B controller board
- The [CN-0288 evaluation software](#)
- The [EVAL-CFTL-6V-PWRZ](#) dc power supply or equivalent 6 V/1 A bench supply
- Measurement Specialties, Inc., E-100 Economy Series LVDT ([EVAL-CFTL-LVDT](#))

Getting Started

Load the evaluation software by placing the [CN-0288 evaluation software](#) into the CD drive of the PC. Using **My Computer**, locate the drive that contains the evaluation software.

Functional Block Diagram

See Figure 1 for the circuit block diagram and the [EVAL-CN0288-SDPZ-PADSSchematic.pdf](#) file for the complete circuit schematic. The PDF file can be found in the [CN-0288 Design Support Package](#).

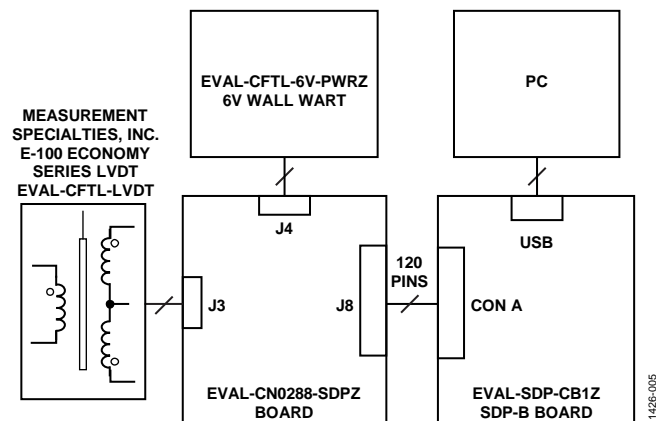

Figure 5. Test Setup Block Diagram

Setup

Connect the 120-pin connector on the [EVAL-CN0288-SDPZ](#) to the CON A connector on the [EVAL-SDP-CB1Z](#) (SDP-B). Use nylon hardware to firmly secure the two boards, using the holes provided at the ends of the 120-pin connectors. With power to the supply off, connect a 6 V power supply to the +6 V and GND pins on the board. If available, a 6 V wall wart can be connected to the barrel connector on the board and used in place of the 6 V power supply. Connect the USB cable supplied with the [EVAL-SDP-CB1Z](#) to the USB port on the PC. Do not connect the USB cable to the Mini-USB connector on the [EVAL-SDP-CB1Z](#) at this time.

Test

Apply power to the 6 V supply (or wall wart) connected to the [EVAL-CN0288-SDPZ](#). Launch the evaluation software and connect the USB cable from the PC to the Mini-USB connector on the [EVAL-SDP-CB1Z](#).

When USB communications are established, the [EVAL-SDP-CB1Z](#) can send, receive, and capture parallel data from the [EVAL-CN0288-SDPZ](#).

Figure 6 shows a photo of the [EVAL-CN0288-SDPZ](#) connected to the [EVAL-SDP-CB1Z](#). Information regarding the [EVAL-SDP-CB1Z](#) can be found in the [UG-277 User Guide](#).

Information and details regarding test setup and calibration, and how to use the evaluation software for data capture can be found in the [CN-0288 Software User Guide](#).

Connectivity for Prototype Development

The [EVAL-CN0288-SDPZ](#) is designed to use the [EVAL-SDP-CB1Z](#); however, any microprocessor can be used to interface to the I²C 2-wire serial interface of the [AD7992](#). In order for another controller to be used with the [EVAL-CN0288-SDPZ](#), software must be developed by a third party.

There are existing interposer boards that can be used to interface to the Altera and Xilinx field programmable gate arrays (FPGAs). The BeMicro SDK board from Altera can be used with the BeMicro SDK/SDP interposer using nios drivers. Any Xilinx evaluation board that features the FMC connector can be used with the FMC-SDP interposer board.

The [EVAL-CN0288-SDPZ](#) is also compatible with the Digilent, Imod interface specification.

A photo of the system is shown in Figure 6.

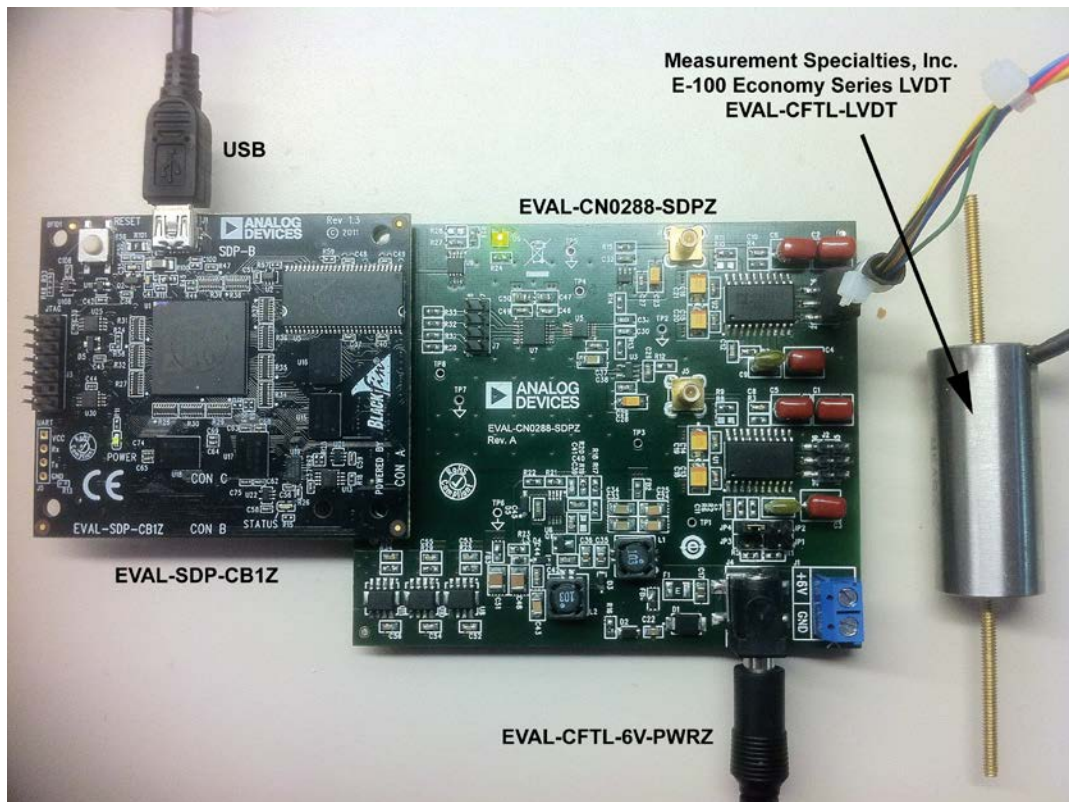

Figure 6. The [EVAL-CN0288-SDPZ](#) Board Connected to [EVAL-SDP-CB1Z](#) (SDP-B) Board and Measurement Specialties, Inc., E-100 Economy Series LVDT

LEARN MORE

CN-0288 Design Support Package:

<http://www.analog.com/CN0288-DesignSupport>

SDP-B User Guide

Ardizzoni, John. A Practical Guide to High-Speed Printed-Circuit-Board Layout. Analog Dialogue 39-09, September 2005.

MT-004 Tutorial, The Good, the Bad, and the Ugly Aspects of ADC Input Noise—Is No Noise Good Noise?, Analog Devices.

MT-031 Tutorial, *Grounding Data Converters and Solving the Mystery of “AGND” and “DGND”*, Analog Devices.

MT-035, *Op Amp Inputs, Outputs, Single-Supply, and Rail-to-Rail Issues*, Analog Devices.

MT-036 Tutorial, *Op Amp Output Phase-Reversal and Input Over-Voltage Protection*, Analog Devices.

MT-068 Tutorial, *Difference and Current Sense Amplifiers*, Analog Devices.

MT-101 Tutorial, *Decoupling Techniques*, Analog Devices.

AN-1106 Application Note, *An Improved Topology for Creating Split Rails from a Single Input Voltage*, Analog Devices.

E-100 Economy Series LVDT, Measurement Specialties, Inc.

The LVDT: construction and principle of operation, Technical Paper, Measurement Specialties, Inc, 1000 Lucas Way, Hampton, VA 23666.

Subminiature LVDTs Provide Accurate Flight Control Surface Position Feedback on UAVs, Application Note, Measurement Specialties, Inc, 1000 Lucas Way, Hampton, VA 23666.

Data Sheets and Evaluation Boards

CN-0288 Circuit Evaluation Board (EVAL-CN0288-SDPZ)

System Demonstration Platform (EVAL-SDP-CB1Z)

AD598 Data Sheet

AD7992 Data Sheet

AD8615 Data Sheet

ADP1613 Data Sheet

ADP7104 Data Sheet

REVISION HISTORY

3/14—Rev. 0 to Rev. A

Changes to Synchronous Operation of Multiple LVDTs Section 4

3/13—Revision 0: Initial Version

(Continued from first page) Circuits from the Lab circuits are intended only for use with Analog Devices products and are the intellectual property of Analog Devices or its licensors. While you may use the Circuits from the Lab circuits in the design of your product, no other license is granted by implication or otherwise under any patents or other intellectual property by application or use of the Circuits from the Lab circuits. Information furnished by Analog Devices is believed to be accurate and reliable. However, Circuits from the Lab circuits are supplied "as is" and without warranties of any kind, express, implied, or statutory including, but not limited to, any implied warranty of merchantability, noninfringement or fitness for a particular purpose and no responsibility is assumed by Analog Devices for their use, nor for any infringements of patents or other rights of third parties that may result from their use. Analog Devices reserves the right to change any Circuits from the Lab circuits at any time without notice but is under no obligation to do so.

X-ON Electronics

Largest Supplier of Electrical and Electronic Components

Click to view similar products for [Other Development Tools](#) category:

Click to view products by [Analog Devices](#) manufacturer:

Other Similar products are found below :

[DS100BR410EVK-4/NOPB](#) [BK0004](#) [BK0012](#) [SN65MLVD2-3EVM](#) [DS80EP100-EVK](#) [MAX9684EVKIT#](#) [MAX4952AEVKIT+](#) [ESD-EVM-001](#) [MAX14842EVKIT+](#) [EVAL01-HMC749LC3C](#) [410-320](#) [TPD6F002-Q1EVM](#) [TS9002DB](#) [DS80PCI800EVK/NOPB](#) [118777-HMC722LC3C](#) [118777-HMC723LC3C](#) [118777-HMC678LC3C](#) [DC1765A-A](#) [125614-HMC851LC3C](#) [TPD1E05U06DPYEVM](#) [SN65LVDM31-32BEVM](#) [DC2062A-A](#) [NB4N855SMEVB](#) [LMH6321MR-EVAL/NOPB](#) [EVAL01-HMC747LC3C](#) [4537](#) [DK-M3F-1.8-TRK-1.5-S](#) [DK-M3-FS-1.8-1.5-M12/16](#) [DK-M3L-1.8-TRK-6.0-S](#) [DK-M3-LS-1.8-6](#) [ADALM1000](#) [ADALP2000](#) [EVAL-CN0202-SDPZ](#) [EVAL-CN0203-SDPZ](#) [EVAL-CN0204-SDPZ](#) [EVAL-CN0209-SDPZ](#) [EVAL-CN0225-SDPZ](#) [EVAL-CN0229-SDPZ](#) [EVAL-CN0251-SDPZ](#) [EVAL-CN0272-SDPZ](#) [EVAL-CN0301-SDPZ](#) [EVAL-CN0325-SDPZ](#) [EVAL-CN0355-PMDZ](#) [EVAL-CN0364-SDPZ](#) [EVAL-SDP-CB1Z](#) [EVAL-SDP-CS1Z](#) [DS1964SEVKIT#](#) [MAX14611EVKIT#](#) [MAX22088EVKIT#](#) [MAX4951AEEVKIT+](#)