

**Circuits  
from the Lab®**  
Reference Designs

*Circuits from the Lab® reference designs are engineered and tested for quick and easy system integration to help solve today's analog, mixed-signal, and RF design challenges. For more information and/or support, visit [www.analog.com/CN0416](http://www.analog.com/CN0416).*

**Devices Connected/Referenced**

<a href="#">ADM2682E</a>	16 Mbps, 5 kV rms Signal and Power Isolated RS-485 Transceiver with $\pm 15$ kV ESD Protection
<a href="#">LTC2865</a>	$\pm 60$ V Fault Protected 3 V to 5.5 V RS-485/RS-422 Transceivers
<a href="#">ADP7102</a>	3.3 V, 300 mA, Low Noise, CMOS LDO

## Robust, Configurable, Isolated and Nonisolated RS-485 Transceiver

### EVALUATION AND DESIGN SUPPORT

#### Circuit Evaluation Boards

[CN-0416 Circuit Evaluation Board \(EVAL-CN0416-ARDZ\)](#)  
[Arduino Form Factor-Compatible Development Board \(EVAL-ADICUP3029\)](#)

#### Design and Integration Files

[Schematics, Layout Files, Bill of Materials](#)

### CIRCUIT FUNCTION AND BENEFITS

The TIA/EIA-485-A, the most widely used transmission line standard of the telecommunication industry, describes the physical layer of the RS-485 interface and is normally used with a higher level protocol, such as Profibus, Interbus, Modbus, or BACnet. Applications include process control networks, industrial automation, remote terminals, building automation (such as heating, ventilation, air conditioning (HVAC)), security systems, motor control, and motion control. The RS-485 interface allows for robust data transmission over relatively long distances (up to 1 km).

The circuit shown in Figure 1 is a universal RS-485 communication platform, implementing both isolated and nonisolated RS-485 designs. The nonisolated circuit provides an extended common-mode range of  $\pm 25$  V, improving on the RS-485 specification of  $-7$  V to  $+12$  V and avoiding the need for isolation in many applications, such as the case when all nodes are supplied and referenced to the same power and ground lines.

The isolated interface, however, allows up to 500 V between the controller ground and RS-485 signals for large scale systems requiring robust communications between remote nodes, such as building-to-building communications. Eliminating common-mode effects in long haul networks requires nodes or repeaters to be isolated from one another and the isolated transceiver, certified in accordance with the UL1577, allows protection and insulation for up to 5000 V between the controller ground and RS-485 signals (1 minute, per UL1577).

The circuit is configurable to operate in full-duplex and half-duplex operations, depending on the application. The termination for each connection can be open or resistance terminated, which allows customers to easily add or remove nodes to the bus lines. Furthermore, the termination resistance is configurable to support standard RS-485 cables or CAT5 Ethernet cables. Power to the device can be sourced from an onboard supply or from the bus power lines.

The circuit can be used for point to point systems or multidrop systems using the onboard address selector. Each circuit can be set as a master device or slave device, depending on the particular application and network in which it is used. The onboard 10-pin connector, compatible with the [ADALM-UARTJTAG](#), allows the master to act as the gateway between a host computer and the RS-485 bus via a USB virtual COM port.

#### Rev. 0

Circuits from the Lab® reference designs from Analog Devices have been designed and built by Analog Devices engineers. Standard engineering practices have been employed in the design and construction of each circuit, and their function and performance have been tested and verified in a lab environment at room temperature. However, you are solely responsible for testing the circuit and determining its suitability and applicability for your use and application. Accordingly, in no event shall Analog Devices be liable for direct, indirect, special, incidental, consequential or punitive damages due to any cause whatsoever connected to the use of any Circuits from the Lab circuits. (Continued on last page)

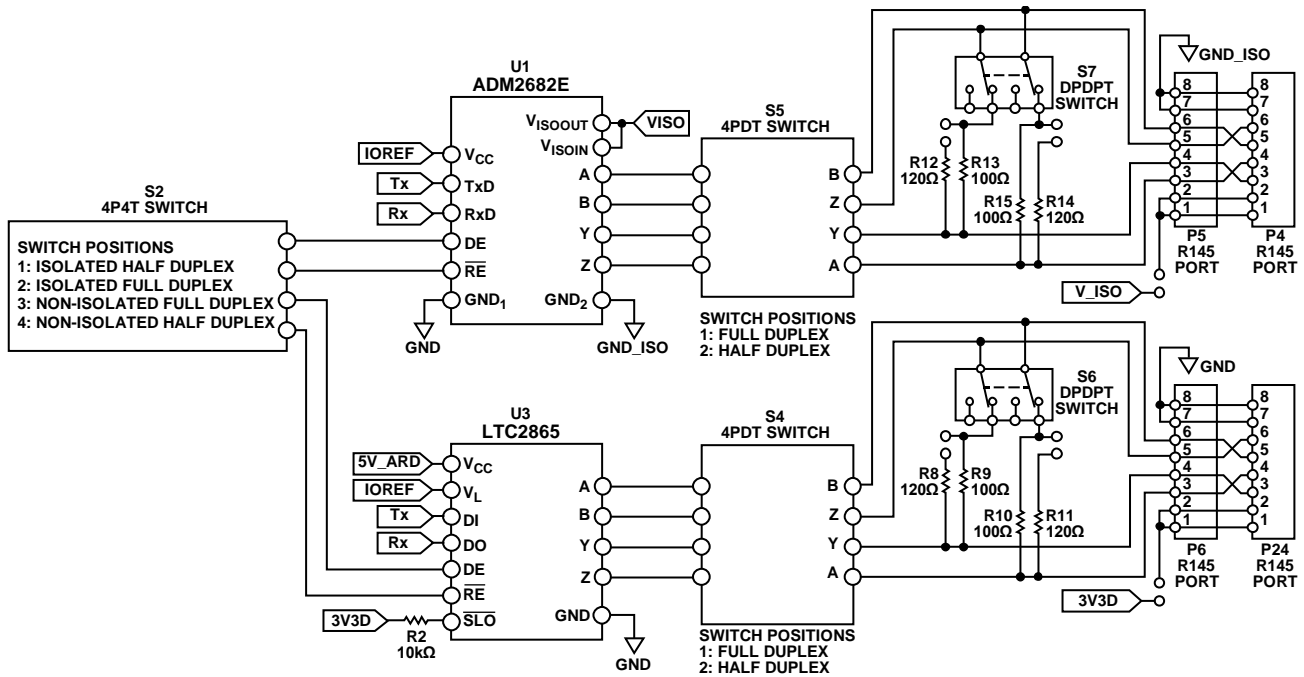

Figure 1. Isolated and Nonisolated RS-485 Transceiver Simplified Schematic

**CIRCUIT DESCRIPTION**

**RS-485 Bus Standard**

The RS-485 bus standard is one of the most commonly used physical layers in industrial applications needing local networks capable of multidrop communication links and long haul data transfer over distances up to 1200 m. A data rate of 10 Mbps is achievable for cable lengths up to 12 m, dropping to 100 kbps at 1200 m, as shown in Figure 2.

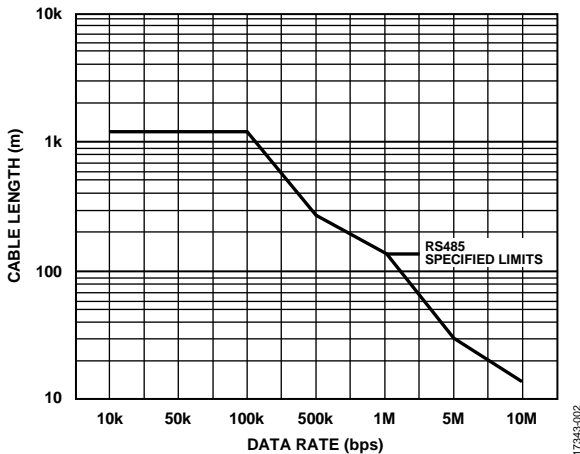

Figure 2. Cable Length vs. Data Rate

Table 1 shows the some of the specifications of the RS-485 bus standard, as well as the improved specifications that the [ADM2682E](#) and [LTC2865](#) provide.

For the full details of each transceiver device, refer to their data sheets. The extended specifications of the [ADM2682E](#) and [LTC2865](#) improve the robustness of systems that are nominally compliant but may occasionally experience events that break the standard. For example, two equipment cabinets in a factory may both be tied to earth ground, with a few volts ac between grounds. However, an ESD strike to one cabinet may momentarily drive its common-mode voltage to 20 V. An [LTC2865](#) rides through such an event, while a transceiver that just meets the standard may produce corrupt data or fail entirely.

The [ADM2682E](#) greatly extends common-mode tolerance, allowing for 25 kV/μs transient immunity, with up to 5000 V potential difference between devices (1 minute, per UL1577). Refer to the [ADM2682E](#) data sheet for details on safety and regulatory approvals.

**Table 1. RS-485 Bus Standard Specifications**

Specification	Standard	ADM2682E	LTC2865
Data Rate	10 Mbps	16 Mbps	20 Mbps
Driver Output Applied Voltage Range	-7 V to +12 V	-9 V to +14 V, isolated	-60 V to +60 V
Receiver Input Voltage Range	-7 V to 12 V	-9 V to +14 V, isolated	-60 V to +60 V
Receiver Input Sensitivity	± 200 mV	-200 to -30 mV	±200 mV
Cable Length	Up to 1200 m	Up to 1200 m	Up to 1200 m
Receiver Input Resistance	≥12 kΩ	96 kΩ	112 kΩ
Number of Drivers and Receivers	32 drivers 32 receivers	256 drivers and receivers	256 drivers and receivers

The inclusion of the isolated and nonisolated transceivers on [EVAL-CN0416-ARDZ](#) aids in determining the actual requirements and implementation of the end application.

The circuit has four on-board Ethernet jacks, one pair for isolated and one pair for nonisolated communications. Whereas Ethernet cable is not intended for RS-485 applications, and the impedance is 100 Ω vs 120 Ω for RS-485, the ubiquity of common CAT5 and CAT6 cables provides a convenient way to build prototype systems during development. Also, each pair of Ethernet ports have crossover pin configurations, allowing the use of straight-through Ethernet cables for multinode systems. Connection points to the RS-485 signals are provided, facilitating the use of other connectors, or direct wiring to the RS-485 cable of the application.

**RS-485 Bus Node Capacity**

Both the [ADM2682E](#) and [LTC2865](#) have 1/8 unit loading of 96 kΩ minimum, allowing up to 256 nodes in a single bus system. (The RS-485 standard specifies a receiver input impedance of 12 kΩ and a maximum of 32 nodes.)

**Termination**

A common guideline for termination is to terminate lines transmitting signals with rise/fall times less than four times the propagation delay of the cable. A standard CAT5 cable has a propagation delay of 4.8 ns/m to 5.3 ns/m. The [ADM2682E](#) and [LTC2865](#) have maximum rise/fall times of 15 ns. Thus, for lines greater than 0.78 m in length, it is recommended to use termination. For best practice, properly terminate all RS-485 systems.

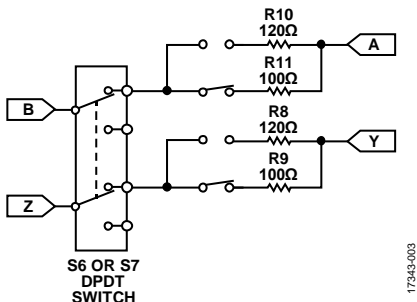

Figure 3. Termination Selection Switches

The circuit shown in Figure 3 can configure the RS-485 line termination to either a differential resistance or left open via S7 for isolated communications and via S6 for nonisolated communications. The full-duplex RS-485 standard requires a termination at the master node and the farthest slave node.

For a half-duplex connection, terminate both ends of the transmission cable. The value of the termination resistance should be equal to the characteristic impedance of the cable. For CAT5 cables, this is 100 Ω. By default, the circuit uses a 100 Ω termination resistance but can be configured through solder links to use the standard RS-485 termination resistance, which is 120 Ω. Table 2 shows the advantages and disadvantages of open and terminated RS-485 communications.

**Table 2. Advantages and Disadvantages of Termination**

Termination	Advantages	Disadvantages
Open or No Termination	Simple, low power	For slow and short communications
Parallel Resistance	Supports long distance and fast communications	High power

**Half Duplex Operation**

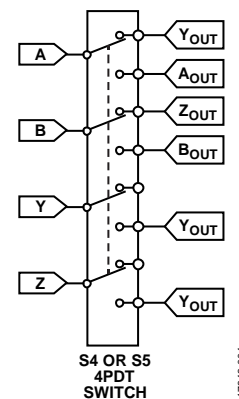

Figure 4. Half- or Full-Duplex Selection Switches

The circuit shown in Figure 4 can be set to operate in half-duplex mode for both isolated and nonisolated communications via Switch S5 and Switch S4, respectively. The driver noninverting output is shorted with the noninverting input of

the receiver, whereas the inverting output of the driver is shorted with the inverting input of the receiver. This configuration allows for a 2-wire RS-485 network, but the bus can only accommodate data transmission in one direction at a time. The driver and receiver enable pins are required to assure that only one driver is enabled to send data at a time. Figure 5 shows the connection setup for a three-slave node half-duplex

isolated RS-485 communication. Slave nodes are connected through similar Ethernet jacks. For example, Slave A P5 is connected to Slave B P5 using a straight-through CAT5 cable. The master node is connected to a slave node via an opposite Ethernet jack. For example, Slave A P5 is connected to P4 of the master node using a straight-through CAT5 cable.

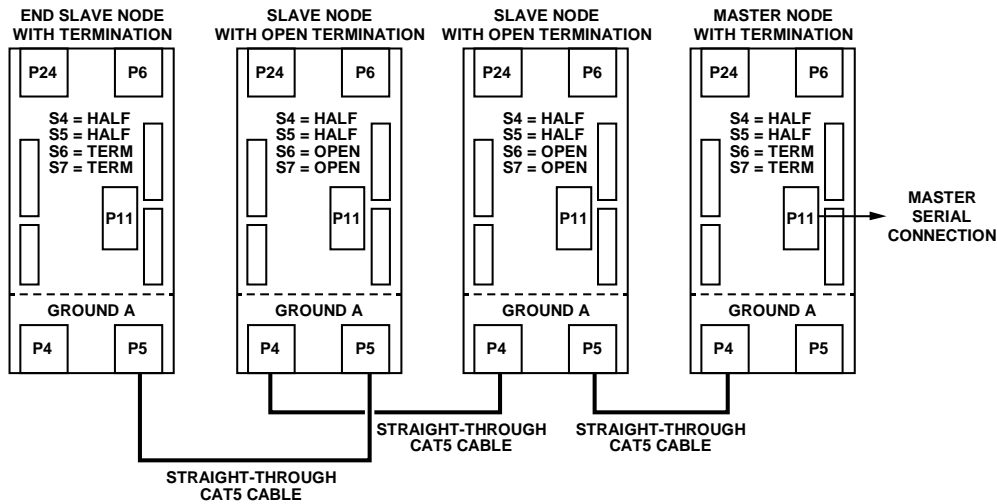

Figure 5. Three Node Half-Duplex Switch Settings and Connection Diagram Using [ADM2682E](#) Isolated RS-485 Communications

Table 3. Nodes and Switch Settings for Figure 5

Type of Node	Switch Settings
Master Node with Termination	S4 = half duplex, S5 = half duplex S6 = terminated, S7 = terminated
Slave Node with Open Termination	S4 = half duplex, S5 = half duplex S6 = open, S7 = open
End Slave Node with Termination	S4 = half duplex, S5 = half duplex S6 = terminated, S7 = terminated

**Full-Duplex Operation**

The circuit shown in Figure 5 can be set to full-duplex mode for both isolated and nonisolated communications via S5 and S4, respectively. In full-duplex mode, the circuit uses all receiver and driver inputs and outputs, respectively. This allows for a 4-wire RS-485 network and can accommodate simultaneous data transmission in both directions between master and slave nodes. Figure 6 shows the connection setup for a three-slave

node full-duplex nonisolated RS-485 communications. Slave nodes are connected through similar Ethernet jacks when using straight-through Ethernet cables. For example, Slave A P6 is connected to Slave B P24 using a straight-through CAT5 cable. The master node is connected to a slave node via an opposite Ethernet jack. For example, Slave A P6 is connected to P24 of the master node using a straight-through CAT5 cable.

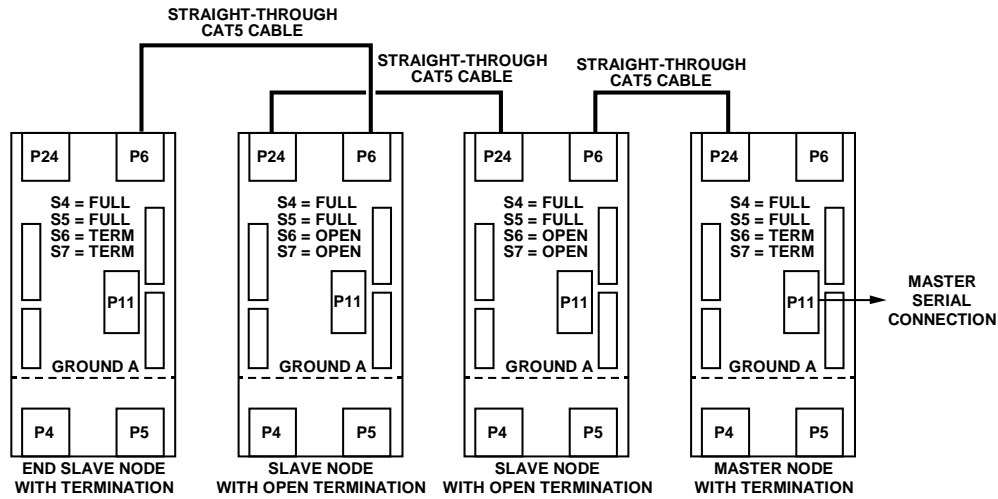

Figure 6. Three Node Full-Duplex Switch Settings and Connection Diagram Using [LTC2865](#)

**Table 4. Node Types and Switch Settings for Figure 6**

Type of Node	Switch Settings
Master Node with Termination	S4 = full duplex, S5 = full duplex S6 = terminated, S7 = terminated
Slave Node with Open Termination	S4 = full duplex, S5 = full duplex S6 = open, S7 = open
End Slave Node with Termination	S4 = full duplex, S5 = full duplex S6 = terminated, S7 = terminated

### True Fail-Safe Receiver Inputs

In multinode systems, a bus idle condition occurs when all nodes are in receive mode. In the bus idle condition, the differential input voltage is 0 V. Previous generation RS-485 receivers required external fail-safe termination and biasing to prevent the bus idle condition from producing erroneous data. Both [ADM2682E](#) and [LTC2865](#) tolerate bus idle conditions without external circuitry.

The [ADM2682E](#) has true fail-safe receiver inputs with a differential input threshold voltage to  $-200$  mV to  $-30$  mV. Thus, the 0 V differential input voltage is received as a defined logic level and prevents random erroneous data from entering or impacting the system.

When a device requires an adjustment to the input threshold voltage, the adjustment causes duty cycle asymmetry at the receiver output, which worsens at low input signal levels and slow input edge rates. The [LTC2865](#) has a full fail-safe operation without adjusting the input threshold voltage. Instead of adjusting the input threshold voltage, the [LTC2865](#) uses an internal window comparator to determine if the input voltage falls between the positive and negative thresholds. If this fail-safe condition persists for more than 3  $\mu$ s, the fail-safe condition asserts and the signal is forced to a high state.

### Signal and Power Isolation

The [CN-0416](#) circuit can be configured via Switch S2 to use either isolated communications through the [ADM2682E](#) or nonisolated communications through the [LTC2865](#).

When using a straight-through Ethernet cable to connect an isolated Ethernet jack to a nonisolated Ethernet jack between two slave nodes, connect P4 to P24 and connect P5 to P6. In contrast, when connecting between a master and a slave node in the same situation, connect P4 to P6 and connect P5 to P24. When the same electrical system is used to power the supplies of all nodes, connecting them all to the same earth ground may reduce the noise produced by ground currents flowing between nodes at different ground potentials. For the single earth ground configuration, the nonisolated RS-485 communication is most applicable.

When different nodes are powered by different electrical systems, especially when they are situated in different buildings, may increase the impedance of the earth ground, which in turn, increases the likelihood of ground currents between nodes. For potential ground current situations, isolated RS-485 communication is required. The [ADM2682E](#) has 5 kV rms signal isolation using an Analog Devices, Inc., *iCoupler*<sup>®</sup> data channel. The [ADM2682E](#) also has 5 kV rms power isolation implemented using an Analog Devices *isoPower*<sup>®</sup>, integrated, isolated dc-to-dc converter.

### COMMON VARIATIONS

The RS-485 lines present in the Ethernet port are the driver and receiver inverting and noninverting inputs, as well as supply and ground lines. Alternative designs use a regular screw terminal for easy wiring of standard RS-485 cables and also include a connection for the shield.

The [EVAL-CN0416-ARDZ](#) board has a connector compatible with the [ADALM-UARTJTAG](#) programming board to easily interface with a PC. Furthermore, the USB-to-serial converter can be selected to have a 3.3 V supply output, achieving current requirements of the [ADM2682E](#) and [LTC2865](#) that eliminate the need for the [ADP7102](#) low dropout regulator. The on-board hex switch can also be removed to reduce cost and the number of general-purpose inputs/outputs (GPIOs), using instead, a full software implementation for node addressing.

### CIRCUIT EVALUATION AND TEST

There are two classes of circuit evaluation or test setups for the [CN-0416](#), one for direct communications, and one for multi-node networks. The direct communications setup is an end node to end node, full-duplex connection. The multinode network features master/slave communication between one master and multiple slaves.

Both setups use the [EVAL-CN0416-ARDZ](#) circuit evaluation board, the [ADALM-UARTJTAG](#) programming board, and the [EVAL-ADICUP3029](#). Serial terminal software is required to send and display test messages. It is recommended to use a serial terminal software, such as Tera Term, that automatically reconnects after plugging or unplugging a device.

### Equipment Needed

- PC with a USB port and Windows 7 (32-bit) or higher
- [EVAL-CN0416-ARDZ](#) circuit evaluation boards
- [ADALM-UARTJTAG](#) boards
- Straight-through RJ45 CAT5/CAT5E cables
- USB to micro-USB cables
- [EVAL-ADICUP3029](#) with their corresponding power supply adapter (loaded with the [CN-0416](#) multinode full-duplex example code)

## GETTING STARTED

A detailed user guide for the [EVAL-CN0416-ARDZ](#) is available on the [Analog Devices Wiki](#). Consult this user guide for all aspects of hardware and software operation.

Before powering all test setups, set the on-board switches in the [EVAL-CN0416-ARDZ](#) to the communication settings corresponding to the test setup.

### Direct Communications Test Setup and Functional Block Diagram

Set the on-board switches of each [EVAL-CN0416-ARDZ](#) board to full duplex with termination. The user can opt to either use isolated or nonisolated communications.

To set up the connection diagram shown in Figure 7, take the following steps:

1. Connect the two [EVAL-CN0416-ARDZ](#) boards to the two [ADALM-UARTJTAG](#) boards via the P11 jumper header.
2. Connect the two [EVAL-CN0416-ARDZ](#) boards together using a straight-through CAT5 cable.
3. Connect the two [ADALM-UARTJTAG](#) programming boards to the PC using the USB-to-microUSB cables.
  - a. Be sure to identify the correct virtual COM ports used by the two [ADALM-UARTJTAG](#) boards.
  - b. On the PC, connect to the first [EVAL-CN0416-ARDZ](#) via a serial terminal connection. Ensure that the baud rate and COM port are set properly.
  - c. On the PC, connect to the second [EVAL-CN0416-ARDZ](#) via a second serial terminal connection. Ensure the baud rate and COM port are set properly.
4. The two serial terminals are now connected to each other via RS-485 communications.

Any message sent by the one terminal is received by the other terminal. Messages between the two serial terminals can be sent and received simultaneously.

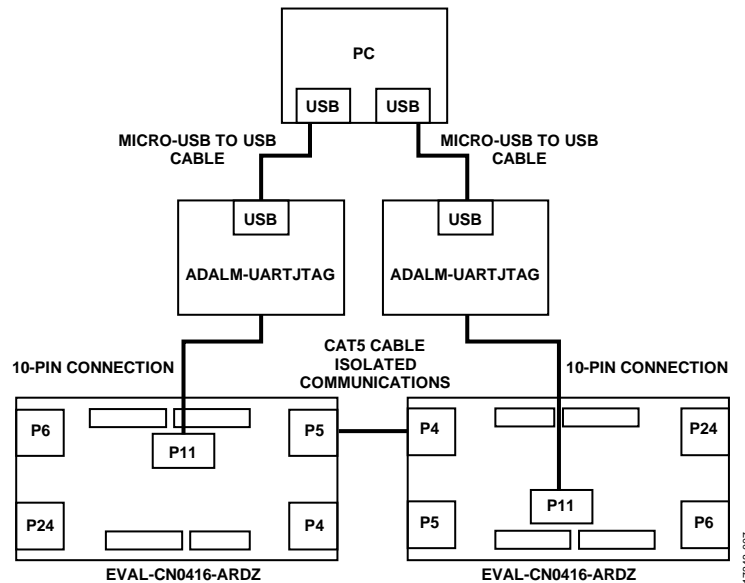

Figure 7. Isolated Full-Duplex RS-485 Connection Diagram for Direct Communications

**Multinode Network Test Setup and Functional Block Diagram**

Figure 8 shows a multinode network setup using both isolated and nonisolated RS-485 transceivers with two different slave nodes interfaced by the EVAL-ADICUP3029. Set up the on-board switches of each EVAL-CN0416-ARDZ board as indicated in Figure 8. Set the hexadecimal selection switch of each board to unique address values.

To setup the network shown in Figure 8, take the following steps:

1. Connect the P11 10-pin connector of the master node to the ADALM-UARTJTAG.

2. Connect the EVAL-CN0416-ARDZ boards in the indicated ports (shown in Figure 8) using straight-through Ethernet cables.
3. Connect the ADALM-UARTJTAG to the PC using the USB-to-microUSB cable.
4. Identify the correct virtual COM port used by the ADALM-UARTJTAG.
5. Open the serial terminal software to connect to the serial port with the baud rate defined by the wiki user guide.
6. Select a slave node to communicate by sending its hexadecimal address (0 to 9 and A to F).
7. Any lowercase letters sent by the master are encrypted by the slave node using a Caesar cipher and sent back to the master, simultaneously.

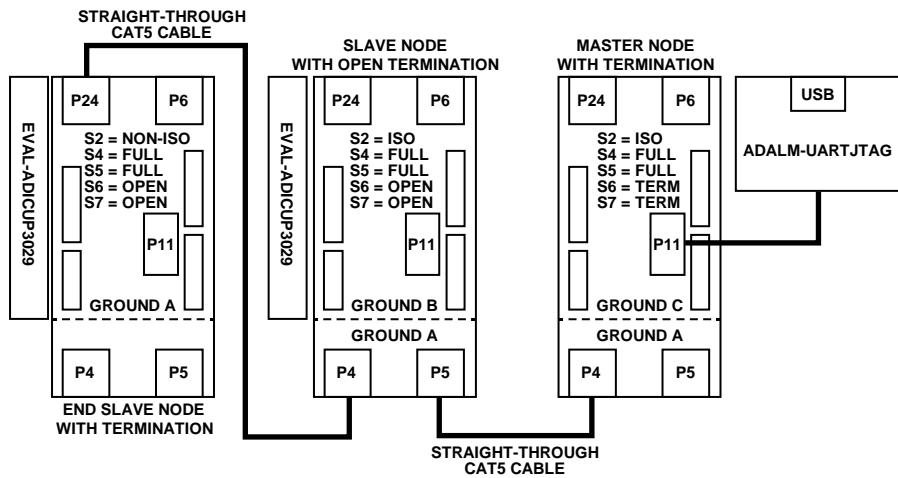

Figure 8. Combination of Isolated and Nonisolated Full-Duplex RS-485 Connection Diagram for Multinode Networks

17343-008



### Power Supply Configuration

When connected appropriately to the [ADALM-UARTJTAG](#) or to the [EVAL-ADICUP3029](#), the [EVAL-CN0416-ARDZ](#) evaluation board receives the necessary voltage to power the circuit.

### LEARN MORE

[CN-0416 Design Support Package: www.analog.com/CN0416-DesignSupport](#)

[ADICUP3029 User Guide](#)

[ADALM-UARTJTAG User Guide](#)

[AN-960 Application Note, RS-584/RS-422 Circuit Implementation Guide](#), Analog Devices.

[RS485 Quick Guide, TIA/EIA-485-A Standard](#), Analog Devices.

### Data Sheets and Evaluation Boards

[CN-0416 Circuit Evaluation Board \(EVAL-CN0416-ARDZ\)](#)

[EVAL-ADICUP3029 Evaluation Board](#)

[ADuCM3029 Data Sheet](#)

[ADM2682E Data Sheet](#)

[LTC2865 Data Sheet](#)

[ADP7102 Data Sheet](#)

### REVISION HISTORY

4/2019—Revision 0: Initial Version

(Continued from first page) Circuits from the Lab reference designs are intended only for use with Analog Devices products and are the intellectual property of Analog Devices or its licensors. While you may use the Circuits from the Lab reference designs in the design of your product, no other license is granted by implication or otherwise under any patents or other intellectual property by application or use of the Circuits from the Lab reference designs. Information furnished by Analog Devices is believed to be accurate and reliable. However, Circuits from the Lab reference designs are supplied "as is" and without warranties of any kind, express, implied, or statutory including, but not limited to, any implied warranty of merchantability, noninfringement or fitness for a particular purpose and no responsibility is assumed by Analog Devices for their use, nor for any infringements of patents or other rights of third parties that may result from their use. Analog Devices reserves the right to change any Circuits from the Lab reference designs at any time without notice but is under no obligation to do so.

©2019 Analog Devices, Inc. All rights reserved. Trademarks and registered trademarks are the property of their respective owners.  
CN17343-0-4/19(0)



## X-ON Electronics

Largest Supplier of Electrical and Electronic Components

*Click to view similar products for [Interface Development Tools](#) category:*

*Click to view products by [Analog Devices](#) manufacturer:*

Other Similar products are found below :

[DP130SSEVM](#) [ISO3086TEVM-436](#) [ADP5585CP-EVALZ](#) [CHA2066-99F](#) [AS8650-DB](#) [MLX80104 TESTINTERFACE](#) [I2C-CPEV/NOPB](#)  
[ISO35TEVM-434](#) [416100120-3](#) [XR18910ILEVB](#) [XR21B1421IL28-0A-EVB](#) [EVAL-ADM2491EEBZ](#) [MAXREFDES23DB#](#)  
[MAX9286COAXEVKIT#](#) [MAX3100EVKIT](#) [MAX13235EEVKIT](#) [MAX14970EVKIT#](#) [XR21B1424IV64-0A-EVB](#) [CMOD232+](#)  
[MAX13042EEVKIT+](#) [MAX14838EVKIT#](#) [MAXCAM705OV635AAA#](#) [MAX9205EVKIT](#) [DS100BR111AEVK/NOPB](#) [DC241C](#)  
[MAX9286RCARH3DB#](#) [MAX13035EEVKIT+](#) [DC1794A](#) [SN65HVS885EVM](#) [EVB81112-A1](#) [DFR0257](#) [ZLR964122L](#) [ZLR88822L](#)  
[DC196A-B](#) [DC196A-A](#) [DC327A](#) [OM13585UL](#) [MAX16972AGEEVKIT#](#) [MARS1-DEMO3-ADAPTER-GEVB](#) [MAX7315EVKIT+](#) [PIM511](#)  
[PIM536](#) [PIM517](#) [DEV-17512](#) [STR-FUSB3307MPX-PPS-GEVK](#) [MAXREFDES177#](#) [EVAL-ADM2567EEBZ](#) [EVAL-ADN4654EBZ](#)  
[MAX9275COAXEVKIT#](#) [MAX2202XEVKIT#](#)