

8-, 10-, 12-Bit Video Speed Hybrid Current & Voltage Out D/A Converter

HDS-0820, -1025, -1250/HDH-0802, -1003, -1205

FEATURES

- 25ns Current Settling to 0.1% (HDS)
- 200ns Voltage Settling to 0.1% (HDH)
- 10mA Current Out (HDS)
- Guaranteed Monotonicity Over Temperature
- No External Parts Required
- Reliable Hybrid Construction

APPLICATIONS

- CRT Vector Displays
- TV Video Reconstruction
- Military Equipment (MIL-STD-883)
- Analytical and Medical Instruments

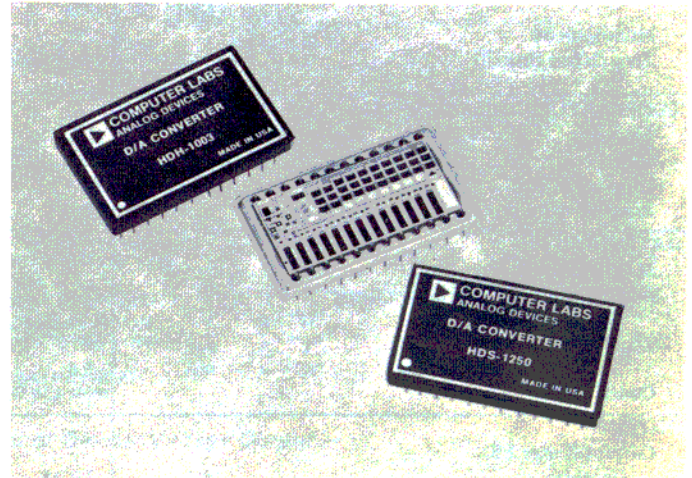

GENERAL DESCRIPTION

The HDS/HDH series of digital to analog converters represent the fastest precision settling current and voltage DAC's available. Capable of processing to MIL-STD-883 and guaranteed monotonicity over their operating temperature range; their quiescent power is 1/2 that of competitive units. The current output models provide 10mA full scale allowing direct drive of capacitive loads and transmission lines. All versions have a precision reference and are active laser trimmed to specified accuracy, thus no external adjustment pots or other components are required.

With 6 available units engineering trade-offs can be made between resolution, speed, current or voltage output, and of course price. To facilitate this comparison major specifications are summarized in Table 1.

Other general specifications that apply to all devices include TTL logic; glass or hermetic metal package; unipolar or bipolar operation with internal offsetting reference.

The HDH voltage output devices provide access to the op amp summing point so that reduced full scale output voltage swing can be provided. Such operation with an external resistor shunting the internal 1k resistor will reduce the already low op amp offset drift.

Model	Resolution	Full Scale Step Settling Time
Current Output		
		10mA Step
HDS-0820	8 Bits	20ns to 0.4%
HDS-1025	10 Bits	25ns to 0.1%
HDS-1250	12 Bits	35ns to 0.025%
Voltage Output		
		10V Step
HDH-0802	8 Bits	200ns to 0.4%
HDH-1003	10 Bits	300ns to 0.1%
HDH-1205	12 Bits	500ns to 0.125%

Table 1.

SPECIFICATIONS (typical @ +25°C with nominal power supply voltages unless otherwise noted)

MODEL	UNITS	CURRENT OUT			VOLTAGE OUT		
		HDS-0820	HDS-1025	HDS-1250	HDH-0802	HDH-1003	HDH-1205
RESOLUTION FS = Full Scale	Bits	8	10	12	8	10	12
LSB WEIGHT		40µA	10µA	2.5µA	40mV	10mV	2.5mV
ACCURACY (Relative to FS Including Linearity)	±% FS	0.1	0.05	0.0125	0.1	0.05	0.0125
Linearity		±10µA	±5µA	±1.25µA	±10mV	±5mV	±1.25mV
Monotonicity	LSB	±1/4	±1/2	±1/2	±1/4	±1/2	±1/2
Zero Offset (Initial)		15nA max	* Guaranteed Over	* Operating Temperature Range	10mV typ 50mV max	*	*
TEMPERATURE COEFFICIENTS							
Linearity	ppm/°C	3	*	*	*	*	*
Gain	ppm/°C	30	*	*	*	*	*
Unipolar Offset	ppm/°C	3	*	*	*	*	*
Bipolar Offset	ppm/°C	15	*	*	*	*	*
DATA INPUTS							
Logic Compatibility			TTL and 5V CMOS				
Logic Voltage Levels Positive Logic	"1" = V	+2 to +7	*	*	*	*	*
	"0" = V	0 to +0.8	*	*	*	*	*
Logic Loading (Each Bit)	"1" = µA	40	*	*	*	*	*
	"0" = mA	-2.6	*	*	*	*	*
Codes			BIN, OBN			BIN, OBN	
OUTPUT							
Current Range FS							
Unipolar	mA	+10.24	*	+10.24 ±0.05%	±25 max	**	**
Bipolar	mA	±5.12	*	±5.12 ±0.025%	±25 max	**	**
Voltage Out FS ^{1,2}							
Unipolar HDS with 200Ω Internal Connected R _L	V	+1.024	*	+1.024 ±0.05%	-10.24 ±0.1%	**	**
Bipolar	V	±0.512	*	±0.512 ±0.025%	±5.12 ±0.05%	**	**
Compliance	V	+1.5, -2	*	*	N/A	**	**
Impedance, Internal (See Figure 1)	Ω	200	*	*	0.1 max	**	**
SETTLING TIME							
Current	ns to % FS	20 to 0.4	25 to 0.1	35 to 0.025	N/A	N/A	N/A
Voltage ²							
Unipolar or Bipolar Out, 75Ω Load, 0.56V p-p	ns to % FS	30 to 0.4	35 to 0.1	50 to 0.025	N/A	N/A	N/A
Unipolar or Bipolar Out, Internal 200Ω Load, 1.024V p-p	ns to % FS	45 to 0.4	50 to 0.1	60 to 0.025	N/A	N/A	N/A
10V Output Step	ns to % FS	N/A	N/A	N/A	200 to 0.4	300 to 0.1	500 to 0.025
5V Output Step	ns to % FS	N/A	N/A	N/A	150 to 0.4	200 to 0.1	350 to 0.025
POWER REQUIREMENTS							
+14.5V to +15.5V	mA max	42	*	50	70	**	**
-12V to -16V	mA max	14	*	15	40	**	**
Power Supply Rejection Ratio	%/V	0.2	*	*	*	*	*
TEMPERATURE RANGE							
Operating — Glass Package	°C	0 to +70	*	*	*	*	*
Operating — "M" Metal Case ³	°C	-55 to +125	*	*	*	*	*
Storage	°C	-55 to +125	*	*	*	*	*
PRICE							
(1-9)	\$	109	119	149	185	195	205

NOTES:

¹ Other voltages may be obtained with external resistor.

² For HDS series, $V_{OUT} = I_{OUT} \times R_{equivalent}$ which is the value of the 200Ω internal impedance in parallel with the external load resistance. Thus, by correct selection of external R1 V_{OUT} can be any magnitude up to the + or - compliance voltage. See Figures 1 and 2.

³ Contact factory or local Analog Devices sales office for "M" Metal Case device specifications and prices.

* Specifications same as HDS-0820.

** Specifications same as HDH-0802.

Specifications subject to change without notice.

OUTLINE DIMENSIONS

Dimensions shown in inches and (mm).

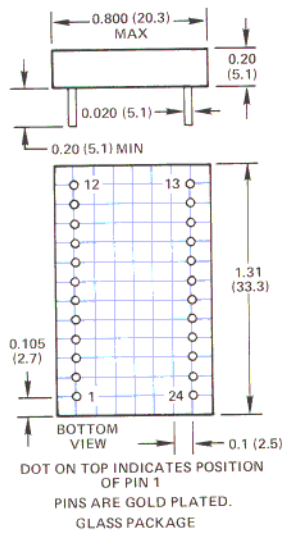

PIN DESIGNATIONS HDS-0820, HDS-1025

PIN	FUNCTION
1	+15V
2, 3	BIT 1 (MSB)
4	BIT 2
5	BIT 3
6	BIT 4
7	BIT 5
8	BIT 6
9	BIT 7
10	BIT 8
11	BIT 9 (HDS-1025)
12	BIT 10
13-20	GND
21	OUTPUT
22	R _L 200Ω
23	BIPOLAR OFFSET
24	-15V

OUTLINE DIMENSIONS

Dimensions shown in inches and (mm).

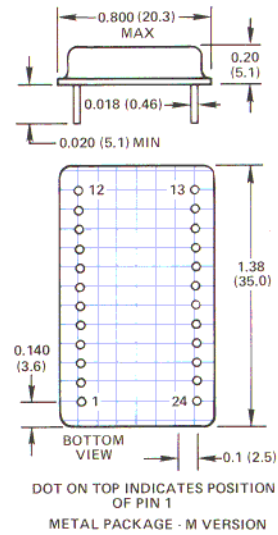

PIN DESIGNATIONS HDS-1250

PIN	FUNCTION
1	BIT 1 (MSB)
2	BIT 2
3	BIT 3
4	BIT 4
5	BIT 5
6	BIT 6
7	BIT 7
8	BIT 8
9	BIT 9
10	BIT 10
11	BIT 11
12	BIT 12
13-19	GND
20	OUTPUT
21	R _L 200Ω
22	BIPOLAR OFFSET
23	-15V
24	+15V

PIN DESIGNATIONS HDH SERIES

PIN	FUNCTION
1	BIT 1 (MSB)
2	BIT 2
3	BIT 3
4	BIT 4
5	BIT 5
6	BIT 6
7	BIT 7
8	BIT 8
9	BIT 9
10	BIT 10
11	BIT 11
12	BIT 12
13-19	GROUND
20	SUM NODE
21	OUTPUT
22	BIPOLAR OFFSET
23	-15V
24	+15V

ON HDH-0802 DEVICES, GROUND PINS 9, 10, 11 AND 12.
ON HDH-1003 DEVICES, GROUND PINS 11 AND 12.

Analog Output, ±5.12mA	Offset Binary
+5.11mA (1LSB)	111.....1
+2.56mA	110.....0
0mA	100.....0
-2.56mA	010.....0
-5.12mA	000.....0

Analog Output, 0 to +10.24mA	Straight Binary
+10.23mA	111.....1
+7.68mA	110.....0
+5.12mA	100.....0
+2.56mA	010.....0
0mA	000.....0

Table 2. Coding HDS Series

Analog Output, ±5.12V	Complement Offset Binary
-5.1175V	111.....1
-2.56V	110.....0
0V	100.....0
+2.56V	010.....0
+5.12V	000.....0

Analog Output, 0 to +10.24V	Complement Binary
-10.2375V	111.....1
-7.68V	110.....0
-5.12V	100.....0
-2.56V	010.....0
0V	000.....0

Table 3. Coding HDH Series

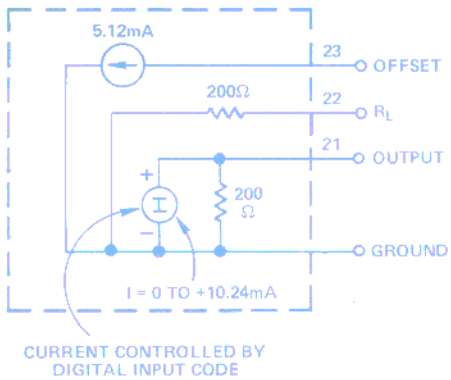

Figure 1. HDS Current Equivalent Circuit

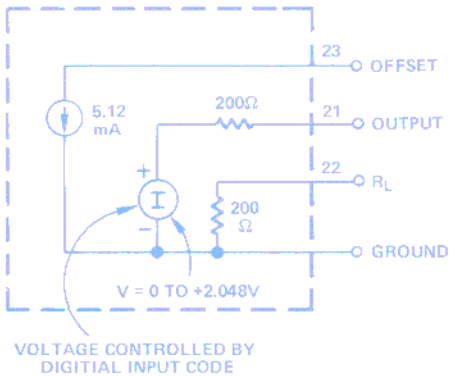

Figure 2. HDS Voltage Equivalent Circuit

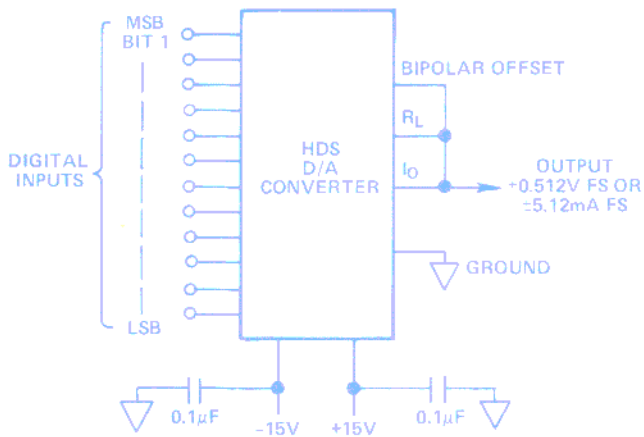

Figure 3. Bipolar Current Output

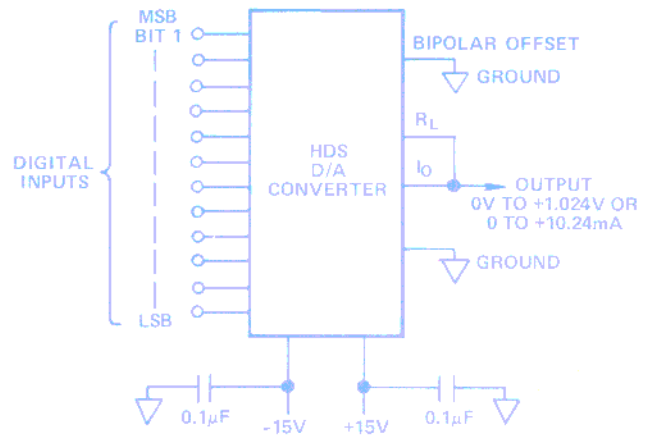

Figure 4. Unipolar Current Output

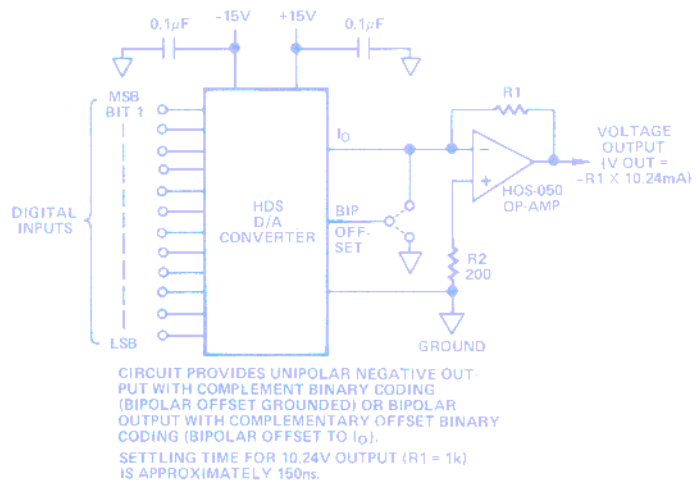
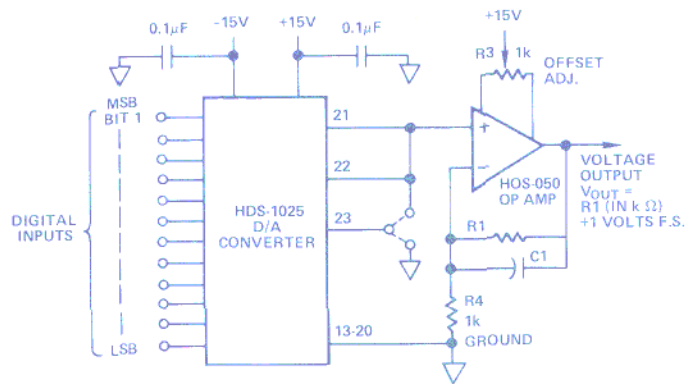

Figure 5. Inverting Unipolar or Bipolar Voltage Output

ORDERING INFORMATION

Order model number HDS-0820, HDS-1025, HDS-1250, HDH-0802, HDH-1003, HDH-1205. Models with extended operating temperature range, hermetically-sealed metal-case construction (M versions) and MIL-STD-883 processing are also available. Consult factory or local Analog Devices sales office for further information.



- NOTES:
1. CIRCUIT SHOWN FOR UNIPOLAR POSITIVE OUTPUT. OUTPUT SETTING TIME IS APPROXIMATELY 150ns.
 2. FOR 0 to +10V OUTPUT, R1 = 9kΩ.
 3. R3 IS ADJUSTED TO COMPENSATE OP-AMP OFFSET.
 4. FOR UNIPOLAR OUTPUT, GROUND PIN 23. FOR BIPOLAR OUTPUT, SHORT PIN 23 TO PIN 21 AND UNGROUND PIN 23.
 5. C1 IS APPROXIMATELY 10pF AND MAY BE ADJUSTED FOR BEST TRANSIENT RESPONSE.

Figure 6. Noninverting Unipolar or Bipolar Voltage Output – HDS-1025

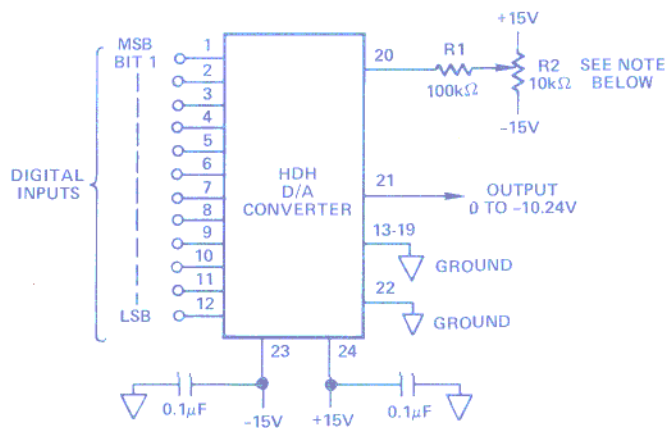

NOTE: R1 and R2 ARE OPTIONAL AND USED ONLY WHEN PRECISE ZEROING OF THE OUTPUT (<10mV) IS REQUIRED.

Figure 7. Unipolar Negative Output

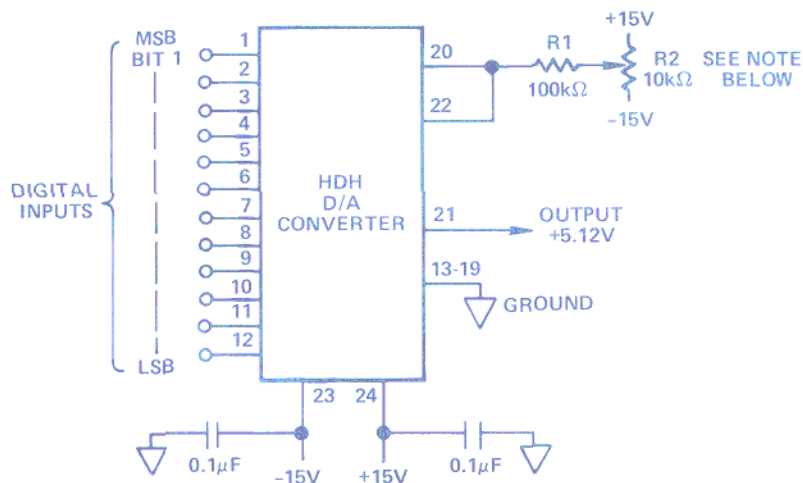

NOTE: R1 AND R2 ARE OPTIONAL AND USED ONLY WHEN PRECISE ZEROING OF THE OUTPUT (<10mV) IS REQUIRED.

Figure 8. Bipolar Output

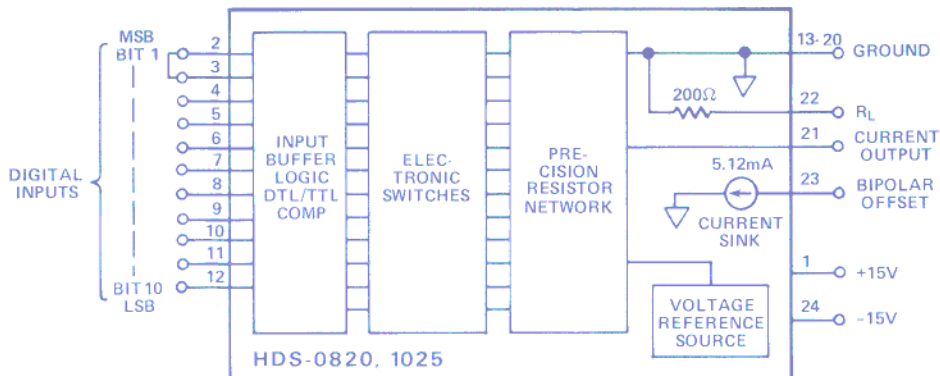

NOTE: ON 8-BIT VERSIONS, PINS 11 AND 12 ARE NOT CONNECTED INTERNALLY, AND PIN 10 IS LSB.

Block Diagram – HDS-0820 and HDS-1025

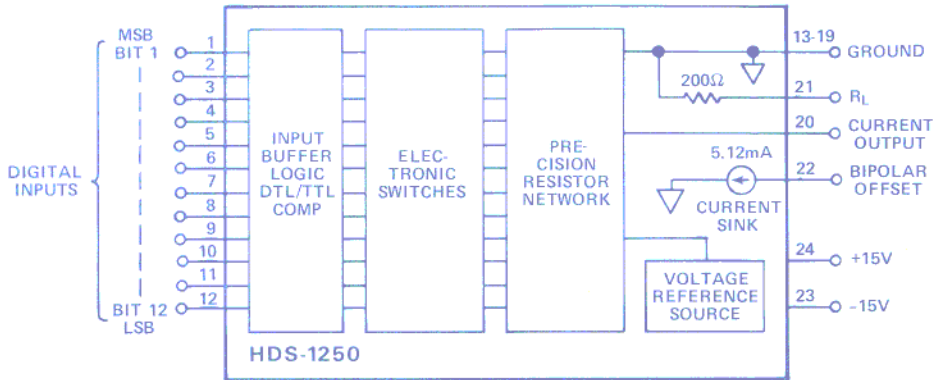

Block Diagram – HDS-1250

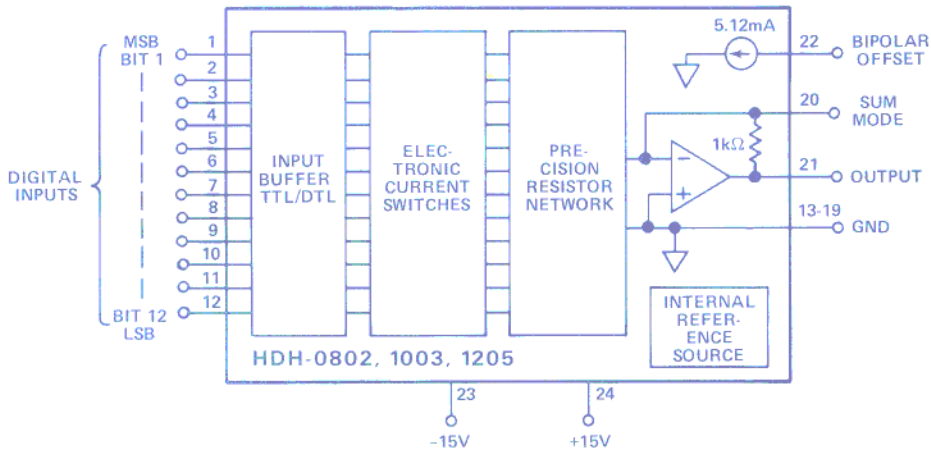

NOTE: ON HDH-0802 DEVICES, GROUND PINS 9, 10, 11 AND 12. ON HDH-1003 DEVICES, GROUND PINS 11 AND 12.

Block Diagram – HDH-0802, HDH-1003 and HDH-1205

X-ON Electronics

Largest Supplier of Electrical and Electronic Components

Click to view similar products for [Digital to Analog Converters - DAC category](#):

Click to view products by [Analog Devices manufacturer](#):

Other Similar products are found below :

[5962-8871903MYA](#) [5962-8876601LA](#) [AD5311BRMZ-REEL7](#) [AD664AJ](#) [AD7534JPZ](#) [TCC-103A-RT](#) [057536E](#) [5962-89657023A](#)
[702423BB](#) [TCC-202A-RT](#) [AD664BE](#) [TCC-303A-RT](#) [TCC-206A-RT](#) [AD5770RBCBZ-RL7](#) [DAC8229FSZ-REEL](#) [AD5673RBCPZ-2](#)
[MCP48FVB28-E/MQ](#) [MCP48FEB18-20E/ST](#) [MCP48FEB18-E/MQ](#) [MCP48FEB24-E/MQ](#) [MCP48FEB28T-20E/ST](#) [MCP47FVB04T-E/MQ](#)
[MCP48FEB28T-E/MQ](#) [MCP48FVB28T-20E/ST](#) [MCP47FVB28T-20E/ST](#) [MCP47FEB24T-E/MQ](#) [MCP48FVB24T-E/MQ](#) [MCP48FVB18T-](#)
[20E/ST](#) [MCP47FEB14T-E/MQ](#) [MCP48FVB14T-20E/ST](#) [MCP48FEB08T-E/MQ](#) [MCP47FEB08T-E/MQ](#) [MCP48FVB08T-20E/ST](#)
[MCP48FEB04T-20E/ST](#) [MCP47FEB04T-E/MQ](#) [MCP48FVB04T-20E/ST](#) [MCP47FVB04T-20E/ST](#) [AD7524JRZ-REEL](#) [LTC1664CGN](#)
[MCP47DA1T-A1E/OT](#) [UC3910D](#) [DAC39J84IAAV](#) [DAC8218SPAG](#) [DAC8562TDGSR](#) [MAX545BCPD+](#) [MAX531BCPD+](#)
[DAC7641YB/250](#) [DAC7611PB](#) [DAC1282IPWR](#) [DAC0800LCM](#)