

## FEATURES

**Broadband frequency range: 0.1 GHz to 20 GHz**

**Nonreflective, 50  $\Omega$  design**

**Low insertion loss: 1.7 dB typical to 20 GHz**

**High isolation: 46 dB typical to 20 GHz**

**High input linearity**

Input P1dB: 25 dBm typical

Input IP3: 41 dBm typical

**High power handling**

27 dBm through path

25 dBm terminated path

**10-pad, 1.3 mm  $\times$  0.85 mm  $\times$  0.102 mm CHIP**

## APPLICATIONS

Test instrumentations

Microwave radios and very small aperture terminals (VSATs)

Military radios, radars, electronic counter measure (ECMs)

Broadband telecommunications systems

## GENERAL DESCRIPTION

The HMC347B is a broadband, nonreflective gallium arsenide (GaAs), pseudomorphic high electron mobility transistor (pHEMT) SPDT monolithic microwave integrated circuit (MMIC) chip. The switch operates from 0.1 GHz to 20 GHz with an insertion loss of 1.7 dB and an isolation of 46 dB to 20 GHz due to the implementation of on-chip, via hole structures.

## FUNCTIONAL BLOCK DIAGRAM

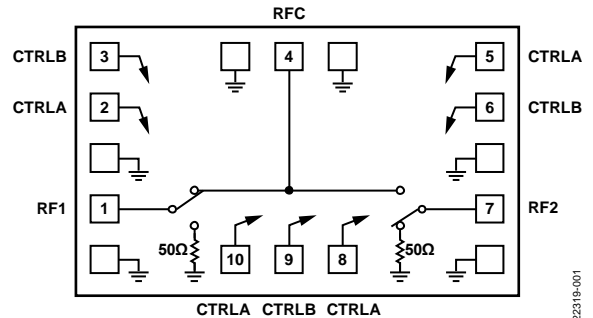

Figure 1.

22319-001

The switch operates with two negative control voltage inputs ( $V_{CTL} = -5$  V or 0 V), requires no supply, and has no current consumption. All electrical performance data is acquired with the RFx pads of the HMC347B connected to 50  $\Omega$  transmission lines via one 3.0 mil  $\times$  0.5 mil ribbon of minimal length.

## TABLE OF CONTENTS

Features .....	1
Applications .....	1
Functional Block Diagram .....	1
General Description .....	1
Revision History .....	2
Specifications .....	3
Absolute Maximum Ratings .....	4
Thermal Resistance .....	4
ESD Caution.....	4
Pin Configuration and Function Descriptions .....	5
Interface Schematics .....	5

## REVISION HISTORY

### 4/2020—Rev. D to Rev. E

Changes to Ordering Guide.....	10
This Hittite Microwave Products data sheet has been reformatted to meet the styles and standards of Analog Devices, Inc.	

### 3/2020—Rev. 03.0518 to Rev. D

Updated Format .....	Universal
Changes to Features Section and General Description Section .....	1
Changes to Table 1 .....	3
Deleted Control Voltages Table .....	3
Changes to Table 2 .....	4
Deleted Suggested Drive Circuit Figure and GND Interface Schematic Figure .....	4
Added Figure 2 and Figure 3; Renumbered Sequentially .....	5
Changes to Table 4 and Figure 4.....	5

Typical Performance Characteristics .....	6
Insertion Loss, Return Loss, and Isolation .....	6
Input P1dB, Input P0.1dB, and Input IP3 .....	7
Theory of Operation .....	8
Applications Information .....	9
Mounting and Bonding Techniques .....	9
Assembly Diagram.....	9
Outline Dimensions.....	10
Ordering Guide .....	10

Deleted Handling Precautions Section, Mounting Section, and Wire Bonding Section.....	6
Added Figure 7 .....	6
Changes to Figure 5, Figure 6, and Figure 8.....	6
Added Figure 9 and Figure 12 to Figure 14.....	7
Changes to Figure 10 and Figure 11 .....	7
Added Theory of Operation Section .....	8
Added Applications Information Section and Assembly Diagram Section .....	9
Changed Mounting & Bonding Techniques for Millimeterwave GaAs MMICs Section to Mounting and Bonding Techniques Section.....	9
Changes to Figure 15 and Figure 16 .....	9
Updated Outline Dimensions .....	10
Changes to Ordering Guide.....	10

## SPECIFICATIONS

Control voltage ( $V_{CTL}$ ) = -5 V or 0 V, die temperature ( $T_{DIE}$ ) = 25°C, 50  $\Omega$  system, unless otherwise noted.

Table 1.

Parameter	Symbol	Test Conditions/Comments	Min	Typ	Max	Unit							
BROADBAND FREQUENCY RANGE	f		0.1		20	GHz							
INSERTION LOSS		0.1 GHz to 10 GHz		1.6		dB							
		0.1 GHz to 20 GHz		1.7	2.2	dB							
ISOLATION Between RFC and RF1 to RF2		0.1 GHz to 10 GHz		52		dB							
		0.1 GHz to 20 GHz	40	46		dB							
RETURN LOSS		0.1 GHz to 20 GHz		RFC	12	dB							
				RF1 and RF2									
				On State	16	dB							
				Off State	18	dB							
SWITCHING CHARACTERISTICS		10% to 90% of RF output		Rise and Fall Time	3	ns							
				On and Off Time	10	ns							
INPUT LINEARITY		0.5 GHz to 20 GHz	23	25		dBm							
							Input 1 dB Compression	$V_{CTL} = -5 V$ or 0 V	24	dBm			
								$V_{CTL} = -3 V$ or 0 V	21	dBm			
							Input 0.1 dB Compression	$V_{CTL} = -5 V$ or 0 V	19	dBm			
								$V_{CTL} = -3 V$ or 0 V					
Input Third-Order Intercept	IP3	10 dBm per tone, 1 MHz spacing		41		dBm							
							$V_{CTL} = -5 V$ or 0 V	41	dBm				
DIGITAL CONTROL INPUTS													
							Voltage	$V_{INL}$					
													Low
							High	$V_{INH}$					V
							Current						
High	$I_{INH}$	$V_{CTL} = -5 V$ to $-3 V$											
			3	$\mu A$									
			10	$\mu A$									

## ABSOLUTE MAXIMUM RATINGS

Table 2.

Parameter	Rating
V <sub>CTL</sub>	-7.5 V dc to +0.5 V
RF Input Power (f = 0.5 GHz to 20 GHz, T <sub>DIE</sub> = 85°C) V <sub>CTL</sub> = -5 V or 0 V	
Through Path	27 dBm
Terminated Path	25 dBm
Hot Switching	23 dBm
V <sub>CTL</sub> = -3 V or 0 V	
Through Path	21 dBm
Terminated Path	19 dBm
Hot Switching	17 dBm
Temperature	
Channel	150°C
Storage	-65°C to +150°C
Operating	-55°C to +85°C
ESD (Electrostatic Discharge) Sensitivity	
Human Body Model (HBM)	Class 0, passed 150 V

Stresses at or above those listed under Absolute Maximum Ratings may cause permanent damage to the product. This is a stress rating only; functional operation of the product at these or any other conditions above those indicated in the operational section of this specification is not implied. Operation beyond the maximum operating conditions for extended periods may affect product reliability.

## THERMAL RESISTANCE

Thermal performance is directly linked to printed circuit board (PCB) design and operating environment. Careful attention to PCB thermal design is required.

$\theta_{JC}$  is the junction to case bottom (channel to package bottom) thermal resistance.

Table 3.

Package Option	$\theta_{JC}$	Unit
C-10-10		
Through Path	118	°C/W
Terminated Path	200	°C/W

## ESD CAUTION



**ESD (electrostatic discharge) sensitive device.** Charged devices and circuit boards can discharge without detection. Although this product features patented or proprietary protection circuitry, damage may occur on devices subjected to high energy ESD. Therefore, proper ESD precautions should be taken to avoid performance degradation or loss of functionality.

# PIN CONFIGURATION AND FUNCTION DESCRIPTIONS

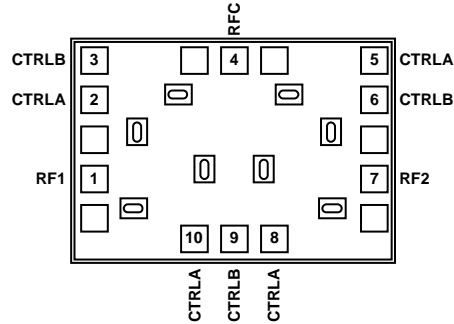

NOTES  
1. DIE BOTTOM MUST BE CONNECTED TO RF GROUND.

Figure 2. Pin Configuration

Table 4. Pin Function Descriptions<sup>1</sup>

Pin No.	Mnemonic	Description
1	RF1	RF Throw Pad 1. This pad is dc-coupled and matched to 50 Ω. Blocking capacitors are required if the RF line potential ≠ 0 V.
2, 5, 8, 10	CTRLA	Control Input A. See Figure 4 for the interface schematic.
3, 6, 9	CTRLB	Control Input B. See Figure 4 for the interface schematic.
4	RFC	RF Common Pad. This pad is dc-coupled and matched to 50 Ω. Blocking capacitors are required if the RF line potential ≠ 0 V.
7	RF2	RF Throw Pad 2. This pad is dc-coupled and matched to 50 Ω. Blocking capacitors are required if the RF line potential ≠ 0 V.
Die Bottom	GND	Die bottom must be connected to RF ground.

<sup>1</sup> No connection is required for the unlabeled grounds.

## INTERFACE SCHEMATICS

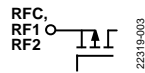

Figure 3. RFC, RF1, and RF2 Interface Schematic

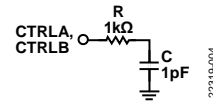

Figure 4. CTRLA, CTRLB Interface Schematic

**TYPICAL PERFORMANCE CHARACTERISTICS**  
**INSERTION LOSS, RETURN LOSS, AND ISOLATION**

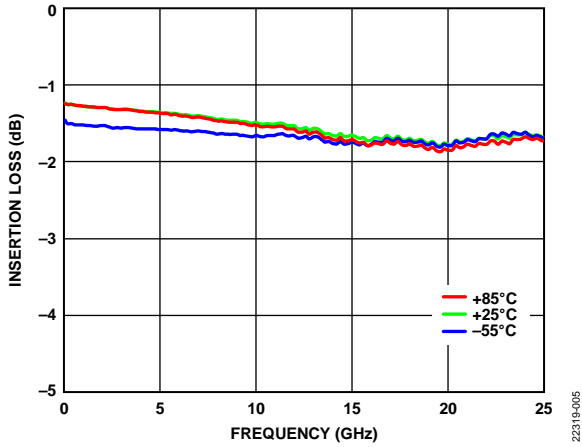

Figure 5. Insertion Loss vs. Frequency over Temperature

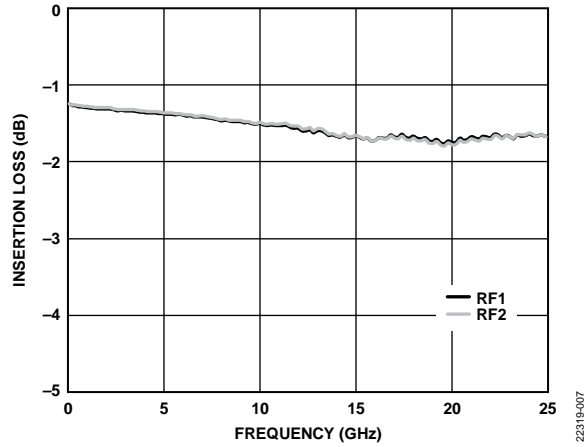

Figure 7. Insertion Loss vs. Frequency, Between RFC and RF1/RF2

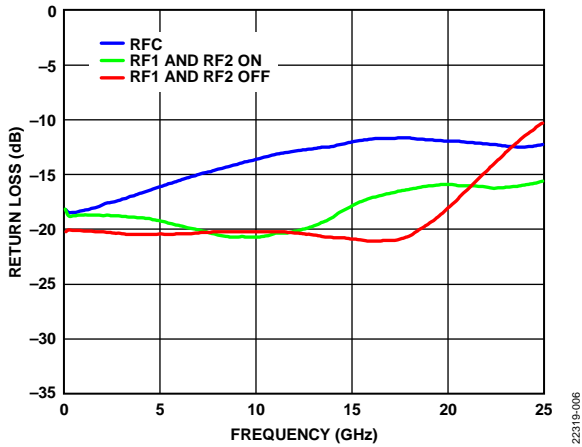

Figure 6. Return Loss vs. Frequency

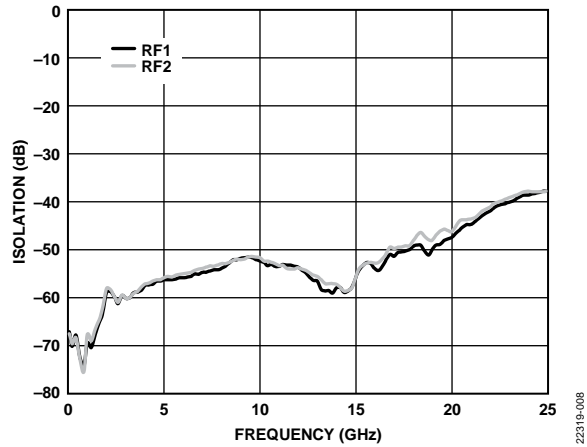

Figure 8. Isolation vs. Frequency, Between RFC and RF1/RF2

INPUT P1dB, INPUT P0.1dB, AND INPUT IP3

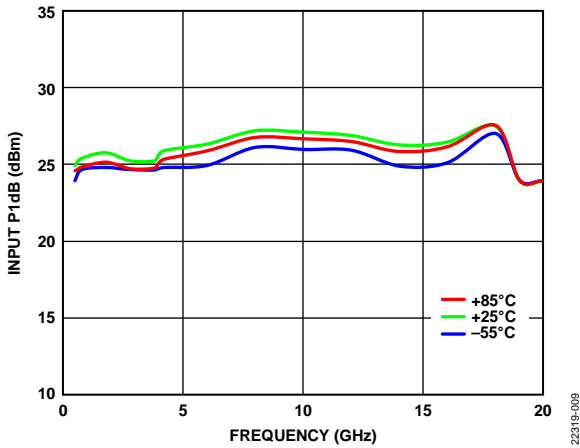

Figure 9. Input P1dB vs. Frequency over Temperature,  $V_{CTL} = -5V$

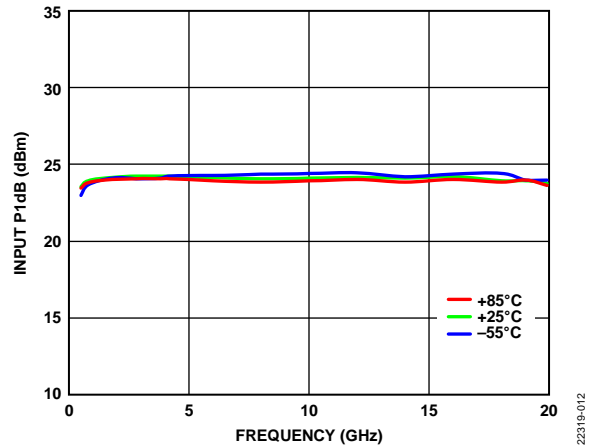

Figure 12. Input P1dB vs. Frequency over Temperature,  $V_{CTL} = -3V$

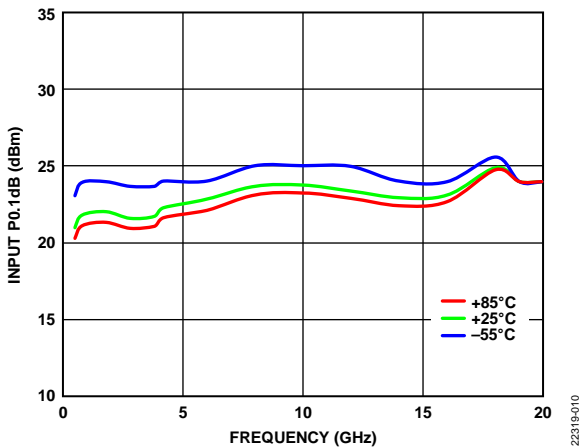

Figure 10. Input P0.1dB vs. Frequency over Temperature,  $V_{CTL} = -5V$

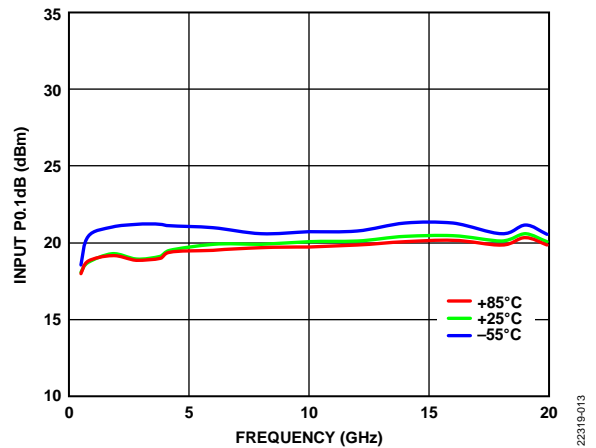

Figure 13. Input P0.1dB vs. Frequency over Temperature,  $V_{CTL} = -3V$

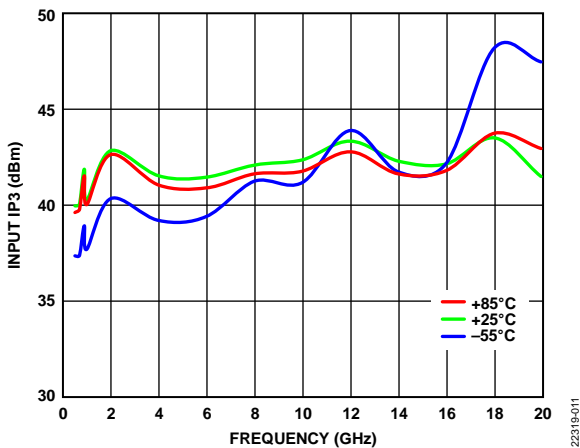

Figure 11. Input IP3 vs. Frequency over Temperature,  $V_{CTL} = -5V$

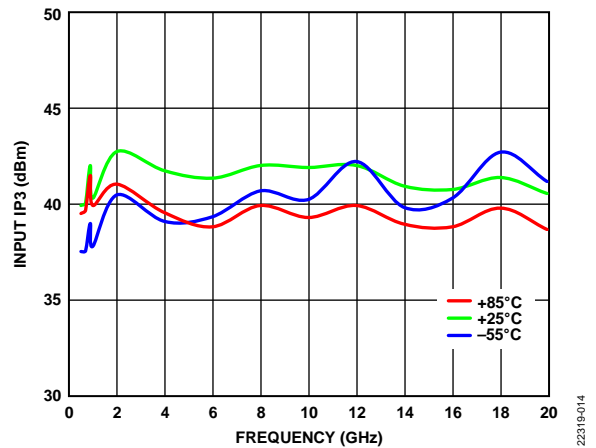

Figure 14. Input IP3 vs. Frequency over Temperature,  $V_{CTL} = -3V$

## THEORY OF OPERATION

The HMC347B requires two negative control voltages at the CTRLx pads to control the state of the RF paths and requires no supply.

Depending on the logic level applied to the CTRLx pads, one RF path is in the insertion loss state and the other path is in the isolation state (see Table 5). The insertion loss path conducts the RF signal between the RF1 pad or RF2 pad and the RFC pad. The isolation path provides high loss between the selected insertion loss path and the unselected RF1 pad or RF2 pad that is terminated to an internal 50  $\Omega$  resistor.

The ideal power-up sequence is as follows:

1. Ground to the die bottom.
2. Power up the digital control inputs. The relative order of the logic control inputs is not important.
3. Apply an RF input signal. The design is bidirectional and the RF input signal can be applied to the RFC pad when the RF1 and RF2 throw pads are outputs, or the RF input signal can be applied to the RF1 and RF2 throw pads when the RFC pad is the output. The RFx pads are dc-coupled to 0 V, and no dc blocking is required at the RFx pads when the RF line potential is equal to 0 V.

The power-down sequence is the reverse of the power-up sequence.

**Table 5. Control Voltage Truth Table**

Digital Control Inputs		RF Paths	
CTRLA	CTRLB	RF1 to RFC	RF2 to RFC
High	Low	Insertion loss (on)	Isolation (off)
Low	High	Isolation (off)	Insertion loss (on)



# APPLICATIONS INFORMATION

## MOUNTING AND BONDING TECHNIQUES

The HMC347B is back metallized and must be attached directly to the ground plane with gold tin (AuSn) eutectic preforms or with electrically conductive epoxy.

The die thickness is 0.102 mm (4 mil). The 50 Ω microstrip transmission lines on 0.127 mm (5 mil) thick, alumina thin film substrates are recommended to bring the RF signal to and from the HMC347B (see Figure 15).

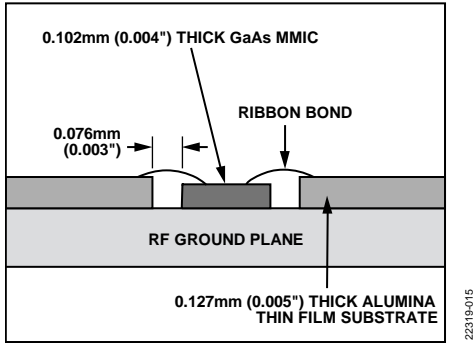

Figure 15. Bonding RF Pads to 5 mil Substrate

When using 0.254 mm (10 mil) thick, alumina thin film substrates, the HMC347B must be raised 0.150 mm (6 mil) so that the surface of the HMC347B is coplanar with the surface of the substrate. The device can be raised by attaching the 0.102 mm (4 mil) thick die to a 0.150 mm (6 mil) thick molybdenum (Mo)

heat spreader (moly tab), which is then attached to the ground plane (see Figure 16).

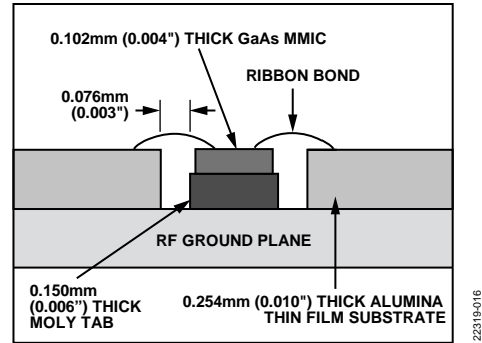

Figure 16. Bonding RF Pads to 10 mil Substrate

Microstrip substrates are placed as close to the HMC347B as possible to minimize bond length. Typical die to substrate spacing is 0.076 mm (3 mil).

RF bonds with 3 mil × 0.5 mil ribbon and dc bonds with 1 mil diameter wire are recommended. All bonds must be as short as possible.

## ASSEMBLY DIAGRAM

An assembly diagram of the HMC347B is shown in Figure 17.

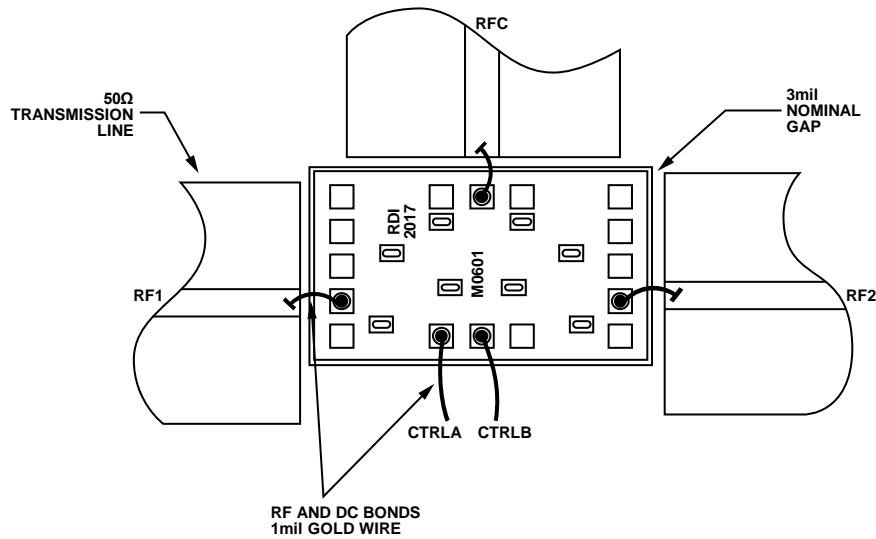
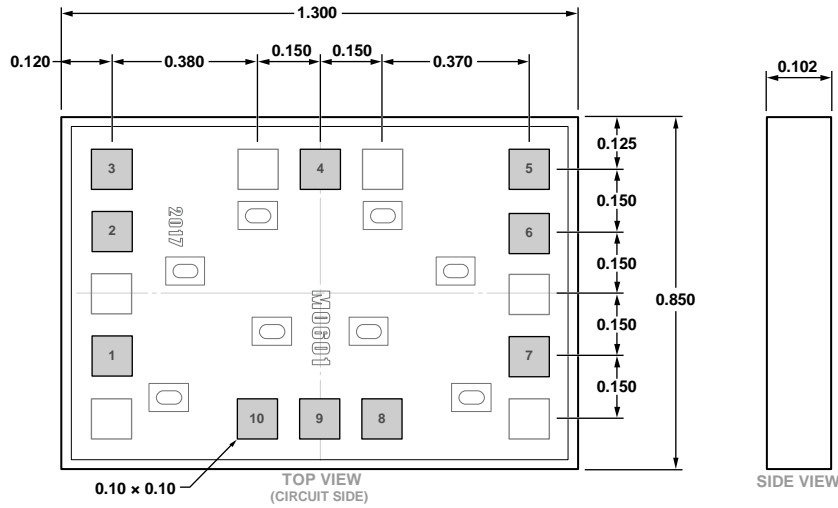

Figure 17. Die Assembly Diagram

OUTLINE DIMENSIONS



09-05-2019-A

Figure 18. 10-Pad Bare Die [CHIP]  
(C-10-10)  
Dimensions shown in millimeters

ORDERING GUIDE

Model <sup>1</sup>	Packing Information	Temperature Range	Package Description	Package Option
HMC347B	Waffle Pack	-55°C to +85°C	10-Pad Bare Die [CHIP]	C-10-10
HMC347B-GP	Gel Pack	-55°C to +85°C	10-Pad Bare Die [CHIP]	C-10-10
HMC347B-SX	Waffle Pack (Sample Order)	-55°C to +85°C	10-Pad Bare Die [CHIP]	C-10-10

<sup>1</sup> All models are RoHS compliant.

## X-ON Electronics

Largest Supplier of Electrical and Electronic Components

*Click to view similar products for [RF Switch ICs](#) category:*

*Click to view products by [Analog Devices](#) manufacturer:*

Other Similar products are found below :

[MASW-008853-TR3000](#) [BGS13SN8E6327XTSA1](#) [BGSX210MA18E6327XTSA1](#) [SKY13446-374LF](#) [SW-227-PIN](#) [CG2185X2](#) [CG2415M6](#)  
[MA4SW410B-1](#) [MASW-002102-13580G](#) [MASW-008543-001SMB](#) [MASW-008955-TR3000](#) [TGS4307](#) [BGS 12PL6 E6327](#)  
[BGS1414MN20E6327XTSA1](#) [BGS1515MN20E6327XTSA1](#) [BGSA11GN10E6327XTSA1](#) [BGSX28MA18E6327XTSA1](#) [HMC199AMS8](#)  
[SKY13374-397LF](#) [SKY13453-385LF](#) [CG2415M6-C2](#) [HMC986A-SX](#) [SW-314-PIN](#) [UPG2162T5N-E2-A](#) [SKY13416-485LF](#)  
[MASWSS0204TR-3000](#) [MASWSS0201TR](#) [MASWSS0181TR-3000](#) [MASW-007588-TR3000](#) [MASW-004103-13655P](#) [MASW-003102-](#)  
[13590G](#) [MASWSS0202TR-3000](#) [MA4SW310B-1](#) [MA4SW110](#) [SW-313-PIN](#) [CG2430X1](#) [SKY13321-360LF](#) [SKY13405-490LF](#)  
[SKYA21001](#) [BGSF 18DM20 E6327](#) [SKY13415-485LF](#) [MMS008PP3](#) [BGS13PN10E6327XTSA1](#) [SKY13319-374LF](#)  
[BGS14PN10E6327XTSA1](#) [SKY12213-478LF](#) [SKY13404-466LF](#) [MASW-011060-TR0500](#) [SKYA21024](#) [SKY85601-11](#)