

1.0 SCOPE

This specification covers the detail requirements for an ultra-low-offset voltage operational amplifier.

It is highly recommended that this data sheet be used as a baseline for new military or aerospace spec control drawings.

1.2 Part Number. The complete part numbers per Table I of this specification follow:

<u>Device</u>	<u>Part Number</u>	<u>Package</u>
X	OP-07J/883	J
A	OP-07AJ/883	J
X	OP-07Z/883	Z
A	OP-07AZ/883	Z
X	OP-07RC/883	RC

1.2.3 Case Outline.

<u>Letter</u>	<u>Case Outline (Lead finish per MIL-M-38510)</u>
J	8-lead metal can (TO-99)
Z	8-lead ceramic dual-in-line package (CERDIP)
RC	20-contact hermetic leadless chip carrier (LCC)

1.3 Absolute Maximum Ratings. ($T_A = 25^\circ\text{C}$, unless otherwise noted)

Supply Voltage.....	$\pm 22\text{V}$
Internal Power Dissipation.....	500mW
Differential Input Voltage.....	$\pm 30\text{V}$
Input Voltage (Note 1).....	$\pm 22\text{V}$
Output Short-Circuit Duration.....	Indefinite
Storage Temperature Range.....	-65°C to $+150^\circ\text{C}$
Lead Temperature (Soldering, 60 sec).....	$+300^\circ\text{C}$
Operating Temperature Range.....	-55°C to $+125^\circ\text{C}$
DICE Junction Temperature Range (T_J).....	-65°C to $+150^\circ\text{C}$

NOTES:

- For supply voltages less than $\pm 22\text{V}$, the absolute maximum input voltage is equal to the supply voltages.

1.5 Thermal Characteristics:

Thermal Resistance, TO-99 (J) package:

Junction-to-Case (θ_{JC}) = 45°C/W MAX

Junction-to-Ambient (θ_{JA}) = 150°C/W MAX

Thermal Resistance, CERDIP (Z) package:

Junction-to-Case (θ_{JC}) = 26°C/W MAX

Junction-to-Ambient (θ_{JA}) = 119°C/W MAX

Thermal Resistance, LCC (RC) package:

Junction-to-Case (θ_{JC}) = 35°C/W MAX

Junction-to-Ambient (θ_{JA}) = 110°C/W MAX

TABLE 1

$V_S = \pm 15V$; $R_S = 50\Omega$; $T_A = 25^\circ C$ unless otherwise specified.

Characteristics	Symbol	Special Conditions	OP-07/883				Units
			LIMITS A		LIMITS X		
			Min	Max	Min	Max	
Input Offset Voltage	V_{OS}		–	25	–	75	μV
		$-55^\circ C \leq T_A \leq +125^\circ C$	–	60	–	200	μV
Average Offset Voltage Drift	TCV_{OS}	$-55^\circ C \leq T_A \leq +125^\circ C$	–	0.6	–	1.3	$\mu V/^\circ C$
Input Offset Current	I_{OS}		–	2.0	–	2.8	nA
		$-55^\circ C \leq T_A \leq +125^\circ C$	–	4.0	–	5.6	nA
Input Bias Current	I_B		–	± 2.0	–	± 3.0	nA
		$-55^\circ C \leq T_A \leq +125^\circ C$	–	± 4.0	–	± 6.0	nA
Output Voltage Swing	V_O	$R_L \geq 10k\Omega$	± 12.5	–	± 12.5	–	V
		$R_L \geq 2k\Omega$	± 12.0	–	± 12.0	–	V
		$R_L \geq 1k\Omega$	± 10.5	–	± 10.5	–	V
		$R_L \geq 2k\Omega$ $-55^\circ C \leq T_A \leq +125^\circ C$	± 12.0	–	± 12.0	–	V
Supply Current	I_{SY}	No Load	–	4	–	4	mA
		No Load, $V_S = \pm 3V$	–	1	–	1	mA
Power Dissipation	P_d	No Load	–	120	–	120	mW
		No Load, $V_S = \pm 3V$	–	6	–	6	mW
Slew Rate	SR	$R_L \geq 2k\Omega, C_L = 50pF$	0.1	–	0.1	–	V/ μs
Input Voltage Range (Note 1)	IVR		± 13	–	± 13	–	V
		$-55^\circ C \leq T_A \leq +125^\circ C$	± 13	–	± 13	–	V
Common-Mode Rejection	CMR	$V_{CM} = IVR = \pm 13V$	110	–	110	–	dB
		$V_{CM} = IVR = \pm 13V$ $-55^\circ C \leq T_A \leq +125^\circ C$	106	–	106	–	dB

TABLE 1 (Continued)

$V_S = \pm 15V$; $R_S = 50\Omega$; $T_A = 25^\circ C$ unless otherwise specified.

Characteristics	Symbol	Special Conditions	OP-07/883				Units
			LIMITS A		LIMITS X		
			Min	Max	Min	Max	
Power Supply Rejection Ratio	PSRR	$V_S = \pm 3V$ to $\pm 18V$ $V_S = \pm 3V$ to $\pm 18V$ $-55^\circ C \leq T_A \leq +125^\circ C$	--	10	--	10	$\mu V/V$
Input Noise Voltage (Note 2)	e_n	$f_O = 1Hz$ to $100Hz$	--	150	--	150	nV_{RMS}
Input Noise Current (Note 2)	i_n	$f_O = 1Hz$ to $100Hz$	--	8	--	8	pA_{RMS}
Open-Loop Voltage Gain	A_{VO}	$R_L \geq 2k\Omega$, $V_O = \pm 10V$ $R_L \geq 2k\Omega$, $V_O = \pm 10V$ $-55^\circ C \leq T_A \leq +125^\circ C$	300	--	200	--	V/mV
Small-Signal Bandwidth	BW	$A_{VCL} = +1$	0.4	--	0.4	--	MHz
Input Offset Adjustment	V_{OSadj+} V_{OSadj-}	$R_p = 20k\Omega$ $R_p = 20k\Omega$	0.5	--	0.5	--	mV
Output Short Circuit	I_{SC+} I_{SC-}		--	58	--	58	mA
			-50	--	-50	--	mA

NOTES:

1. IVR is defined as the V_{CM} range used for the CMR test.
2. This parameter is 100% tested.

TABLE 2

OP-07/883

**Electrical Test Requirements
For Class B Devices**

MIL-STD-883 Test Requirements	Subgroups (see Table 3)
Interim Electrical Parameters (pre Burn-In)	1
Final Electrical Test Parameters	1*, 2, 3, 4
Group A Test Requirements	1, 2, 3, 4, 7, 8

* PDA applies to Subgroup 1 only.
No other Subgroups are included in PDA.
 V_{OS} is excluded from PDA calculation.

TABLE 3

Group A Inspection

$V_S = \pm 15V$; $R_S = 50\Omega$; $T_A = T_J$ unless otherwise specified.

Subgroup	Symbol	Special Conditions	OP-07/883				Units
			LIMITS A		LIMITS X		
			Min	Max	Min	Max	
Subgroup 1 $T_A = +25^\circ C$	I_{OS}		-	2.0	-	2.8	nA
	I_B		-	± 2.0	-	± 3.0	nA
	CMR	$V_{CM} = \pm 13V$	110	-	110	-	dB
	PSRR	$V_S = \pm 3V, \pm 18V$	-	10	-	10	$\mu V/V$
	A_{VO}	$R_L = 2k\Omega, V_O = \pm 10V$	300	-	200	-	V/mV
	V_O	$R_L = 10k\Omega$	± 12.5	-	± 12.5	-	V
		$R_L = 2k\Omega$	± 12.0	-	± 12.0	-	V
		$R_L = 1k\Omega$	± 10.5	-	± 10.5	-	V
	P_d	No Load	-	120	-	120	mW
		No Load, $V_S = \pm 3V$	-	6	-	6	mW
	V_{OSadj+}	$R_p = 20k\Omega$	0.5	-	0.5	-	mV
	V_{OSadj-}	$R_p = 20k\Omega$	-	-0.5	-	-0.5	mV
	I_{SC+}		-	58	-	58	mA
I_{SC-}		-50	-	-50	-	mA	
Subgroup 2 $T_A = +125^\circ C$	I_{OS}		-	4.0	-	5.6	nA
	I_B		-	± 4.0	-	± 6.0	nA
	CMR	$V_{CM} = \pm 13V$	106	-	106	-	dB
	PSRR	$V_S = \pm 3V, \pm 18V$	-	20	-	20	$\mu V/V$
	A_{VO}	$R_L = 2k\Omega, V_O = \pm 10V$	200	-	150	-	V/mV
	V_O	$R_L = 2k\Omega$	+12	-	+12	-	V

TABLE 3

Group A Inspection (Continued)

$V_S = \pm 15V$; $R_S = 50\Omega$; $T_A = T_J$ unless otherwise specified.

Subgroup	Symbol	Special Conditions	OP-07/883				Units
			LIMITS A		LIMITS X		
			Min	Max	Min	Max	
Subgroup 2 $T_A = +125^\circ C$ (Continued)	V_{OS}		-	60	-	200	μV
Subgroup 3 $T_A = -55^\circ C$		All Tests, Limits and Conditions are the same as for Subgroup 2.					
Subgroup 4 $T_A = +25^\circ C$	V_{OS}		-	25	-	75	μV
Subgroup 7 $T_A = +25^\circ C$	BW	$A_{VCL} = +1$	0.4	-	0.4	-	MHz
	SR	$R_L = 2k\Omega, C_L = 50pF$	0.1	-	0.1	-	$V/\mu s$
Subgroup 8 $-55^\circ C \leq T_A \leq +125^\circ C$	TCV_{OS}		-	0.6	-	1.3	$\mu V/^\circ C$

OPERATIONAL AMPLIFIERS 12

OP-07

3.2.1 Simplified Schematic and Pin Connections.

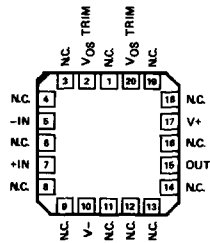
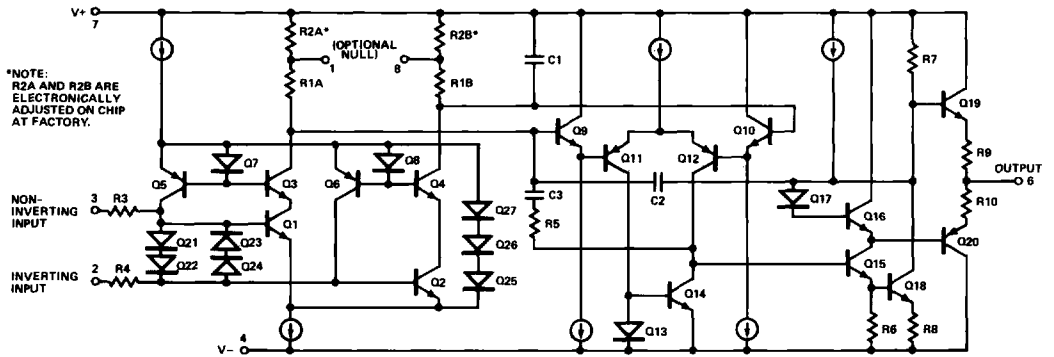

OP-07BRC/883
LCC
(RC-Suffix)

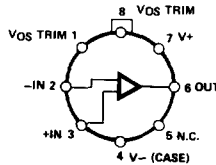

TO-99
(J-Suffix)

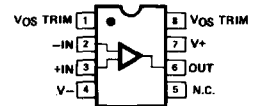

8-PIN HERMETIC DIP
(Z-Suffix)

3.2.4 Microcircuit Group Assignment. This microcircuit is covered by microcircuit group 49.

4.2 Life Test/Burn-In Circuit.

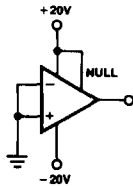

J AND Z PACKAGES

X-ON Electronics

Largest Supplier of Electrical and Electronic Components

Click to view similar products for [Instrumentation Amplifiers](#) category:

Click to view products by [Analog Devices](#) manufacturer:

Other Similar products are found below :

[ADA4254RU-EBZ](#) [MCP6N16-001E/MF](#) [LT1102IN8#PBF](#) [AD694BRZ-REEL7](#) [LT1101ISW](#) [AD521JDZ](#) [AD521KDZ](#) [AD521LDZ](#)
[AD524ADZ](#) [AD524BDZ](#) [AD524CDZ](#) [AD620ANZ](#) [AD621BNZ](#) [AD621BR](#) [AD622ANZ](#) [AD623ANZ](#) [AD623BNZ](#) [AD624ADZ](#)
[AD624CDZ](#) [AD624SD/883B](#) [AD625ADZ](#) [AD625BDZ](#) [AD625JNZ](#) [AD625KNZ](#) [AD625SD](#) [AD627BNZ](#) [AD693AD](#) [AD693AE](#) [AD693AQ](#)
[AD694AQ](#) [AD694ARZ-REEL](#) [AD694BRZ-REEL](#) [AD694JNZ](#) [AD8221ARMZ-R7](#) [AD8224BCPZ-WP](#) [AD8224HBCPZ-WP](#)
[AD8226ARMZ-R7](#) [AD8228ARMZ](#) [AD8228ARMZ-R7](#) [AD8229HDZ](#) [AD8236ARMZ-R7](#) [AD8237ARMZ-R7](#) [AD8253ARMZ](#)
[AD8293G160BRJZ-R7](#) [AD8293G80BRJZ-R2](#) [AD8553ARMZ](#) [AD8553ARMZ-REEL](#) [AD8555ACPZ-REEL7](#) [AD8556ACPZ-R2](#)
[AD8556ACPZ-REEL7](#)