

## 6MHz CMOS Rail-to-Rail IO Opamps

### General Description

The LMV82X have a high gain-bandwidth product of 6MHz, a slew rate of 4.2V/ $\mu$ s, and a quiescent current of 470 $\mu$ A per amplifier at 5V. The LMV82X are designed to provide optimal performance in low voltage and low noise systems. They provide rail-to-rail output swing into heavy loads. The input common mode voltage range includes ground, and the maximum input offset voltage is 3.5mV for LMV82X. They are specified over the extended industrial temperature range (-40°C to +125°C). The operating range is from 2.1V to 5.5V. The LMV821 single is available in Green SC70-5, SOT23-5 and SOP-8 packages.

The LMV822 dual is available in Green SOP-8 and MSOP-8 packages. The LMV824 Quad is available in Green SOP-14 and TSSOP-14 packages.

### Features

- Single-Supply Operation from +2.1V~+5.5V
- Rail-to-Rail Input / Output
- Gain-Bandwidth Product: 6MHz (Typ)
- Low Input Bias Current: 1pA (Typ)
- Low Offset Voltage: 3.5mV (Max)
- Quiescent Current: 470 $\mu$ A per Amplifier (Typ)
- Operating Temperature: -40°C ~ +125°C
- Small Package:  
LMV821 Available in SOT23-5, SOP-8 and SC70-5 Packages  
LMV822 Available in SOP-8 and MSOP-8 Packages  
LMV824 Available in SOP-14 and TSSOP-14 Packages

### Applications

- Sensors
- Active Filters
- Cellular and Cordless Phones
- Laptops and PDAs
- Audio
- Handheld Test Equipment
- Battery-Powered Instrumentation
- A/D Converters

### Ordering Information

DEVICE	Package Type	MARKING	Packing	Packing Qty
LMV821IDBVRG	SOT23-5	V821	REEL	3000pcs/reel
LMV821IDCKRG	SC70-5	V821	REEL	3000pcs/reel
LMV821IDRG	SOP8	LMV821	REEL	2500pcs/reel
LMV822IDRG	SOP8	LMV822	REEL	2500pcs/reel
LMV822IDGKRG	MSOP8	V822	REEL	3000pcs/reel
LMV824IDRG	SOP14	LMV824	REEL	2500pcs/reel
LMV824IPWRG	TSSOP14	LMV824	REEL	2500pcs/reel

## Pin Configuration

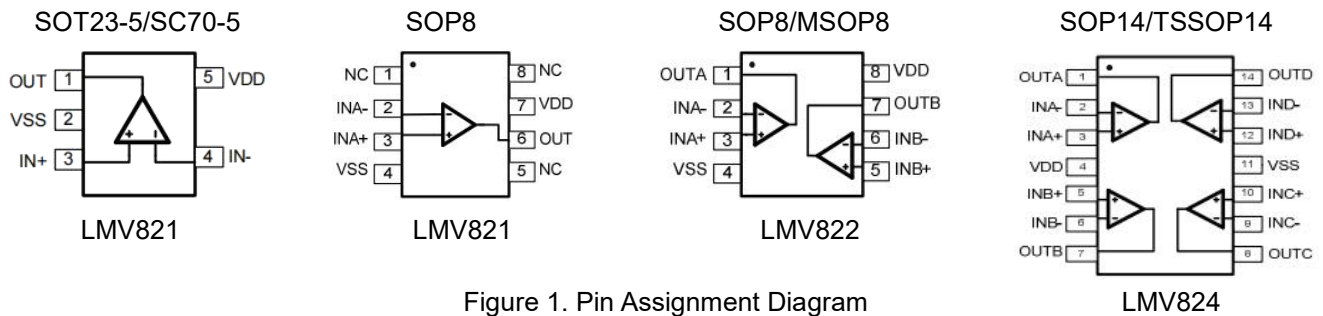

Figure 1. Pin Assignment Diagram

## Absolute Maximum Ratings

Condition		Min	Max
Power Supply Voltage (VDD to Vss)		-0.5V	+7.5V
Analog Input Voltage (IN+ or IN-)		Vss-0.5V	VDD+0.5V
PDB Input Voltage		Vss-0.5V	+7V
Operating Temperature Range		-40°C	+125°C
Junction Temperature		-	+160°C
Storage Temperature Range		-55°C	+150°C
Lead Temperature (soldering, 10sec)		-	+260°C
<b>Package Thermal Resistance (TA=+25°C)</b>	SOP-8, $\theta_{JA}$	-	125°C/W
	MSOP-8, $\theta_{JA}$	-	216°C/W
	SOT23-5, $\theta_{JA}$	-	190°C/W
	SC70-5, $\theta_{JA}$	-	333°C/W
<b>ESD Susceptibility</b>	HBM	-	8KV
	MM	-	400V

**Note:** Stress greater than those listed under Absolute Maximum Ratings may cause permanent damage to the device. This is a stress rating only and functional operation of the device at these or any other conditions outside those indicated in the operational sections of this specification are not implied. Exposure to absolute maximum rating conditions for extended periods may affect reliability.

**Electrical Characteristics**

 (At  $V_S=5V$ ,  $T_A = +25^\circ C$ ,  $V_{CM} = V_S/2$ ,  $R_L = 600\Omega$ , unless otherwise noted.)

PARAMETER	CONDITIONS	LMV821/822/824							
		TYP	MIN/MAX OVER TEMPERATURE					UNITS	MIN / MAX
		+25°C	+25°C	0°C to 70°C	-40°C To 85°C	-40°C to 125°C			
<b>INPUT CHARACTERISTICS</b>									
Input Offset Voltage (VOS)	$V_S = 5.5V$	0.8	3.5	3.9	4.3	4.6	mV	MAX	
Input Bias Current (IB)		1					pA	TYP	
Input Offset Current (IOS)		1					pA	TYP	
Input Common Mode Voltage Range (VCM)		-0.1 to +5.6					V	TYP	
Common Mode Rejection Ratio (CMRR)	$V_S = 5.5V, V_{CM} = -0.1V$ to 4V	90	73	70	70	65	dB	MIN	
	$V_S = 5.5V, V_{CM} = -0.1V$ to 5.6V	83					dB	MIN	
Open-Loop Voltage Gain (AOL)	$R_L = 600\Omega, V_O = 0.15V$ to 4.85V	97	90	87	86	79	dB	MIN	
	$R_L = 10k\Omega, V_O = 0.05V$ to 4.95V	108					dB	MIN	
Input Offset Voltage Drift ( $\Delta V_{OS}/\Delta T$ )		2.4					$\mu V/^\circ C$	TYP	
<b>OUTPUT CHARACTERISTICS</b>									
Output Voltage Swing from Rail	$R_L = 600\Omega$	0.1					V	TYP	
	$R_L = 10k\Omega$	0.015					V	TYP	
Output Current (IOUT)		53	49	45	40	35	mA	MIN	
Closed-Loop Output Impedance	$f = 200kHz, G = 1$	3					$\Omega$	TYP	
<b>POWER-DOWN DISABLE</b>									
Turn-On Time		4					$\mu s$	TYP	
Turn-Off Time		1.2					$\mu s$	TYP	
<b>POWER SUPPLY</b>									
Operating Voltage Range	$V_S = +2.5V$ to +5.5V $V_{CM} = (-V_S) + 0.5V$ IOUT = 0		2.1	2.1	2.1	2.1	V	MIN	
			5.5	5.5	5.5	5.5	V	MAX	
Power Supply Rejection Ratio (PSRR)		91	74	72	72	68	dB $\mu A$	MIN	
		470	650	727	750	815		MAX	
Quiescent Current/Amplifier (IQ)									

**Electrical Characteristics**

 (At  $V_s=5V$ ,  $T_A = +25^\circ C$ ,  $V_{CM} = V_S/2$ ,  $R_L = 600\Omega$ , unless otherwise noted.)

PARAMETER	CONDITIONS	LMV821/822/824							
		TYP	MIN/MAX OVER TEMPERATURE					UNITS	MIN/ MAX
		+25°C	+25°C	0°C to 70°C	-40°C to 85°C	-40°C to 125°C			
<b>DYNAMIC PERFORMANCE</b>									
Gain-Bandwidth Product (GBP)	$R_L = 10k\Omega$ , $C_L = 100pF$	6						MHz	TYP
Phase Margin ( $\phi_O$ )	$R_L = 10k\Omega$ , $C_L = 100pF$	53						Degrees	TYP
Full Power Bandwidth (BWP)	<1% distortion, $R_L = 600\Omega$	250						kHz	TYP
Slew Rate (SR)	$G = +1$ , 2V Step, $R_L = 10k\Omega$	4.2						V/ $\mu s$	TYP
Settling Time to 0.1% ( $t_S$ )	$G = +1$ , 2V Step, $R_L = 600\Omega$	0.4						$\mu s$	TYP
Overload Recovery Time	$V_{IN} \cdot Gain = V_S$ , $R_L = 600\Omega$	2.5						$\mu s$	TYP
<b>NOISE PERFORMANCE</b>									
Voltage Noise Density ( $e_n$ )	$f = 1kHz$	13						$nV\sqrt{Hz}$	TYP
	$f = 10kHz$	9.5						$nV\sqrt{Hz}$	TYP



## Typical Performance characteristics

(At  $V_s=5V$ ,  $T_A = +25^\circ C$ ,  $V_{CM} = V_S/2$ ,  $R_L = 600\Omega$ , unless otherwise noted.)

Large-Signal Step Response

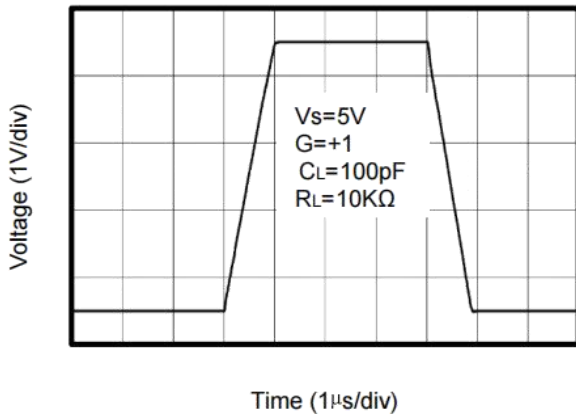

Large-Signal Step Response

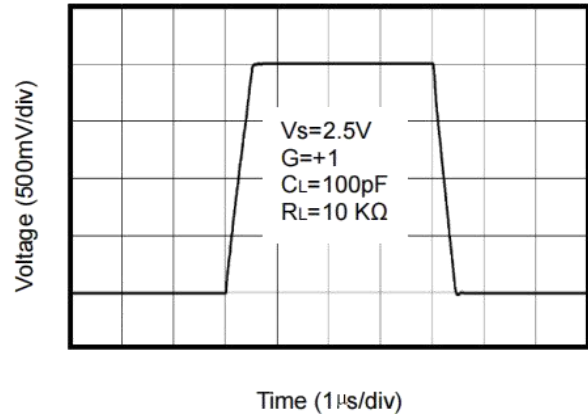

Small-Signal Step Response

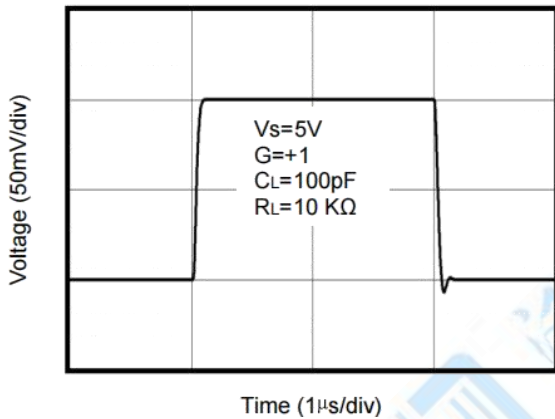

Small-Signal Step Response

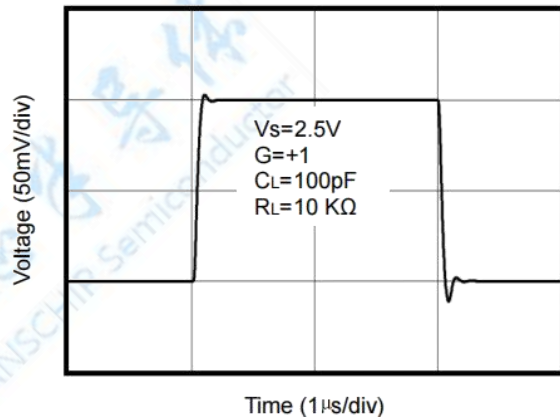

Positive Overload Recovery

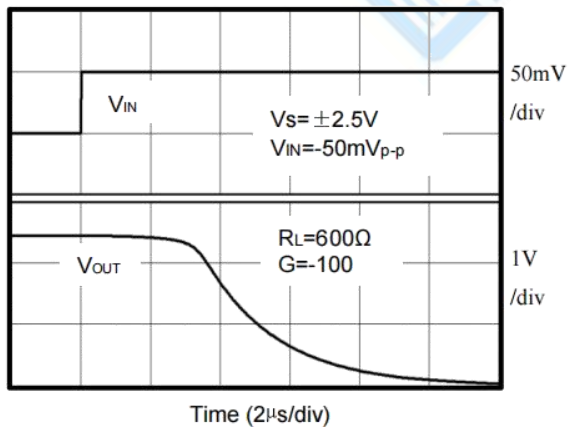

Negative Overload Recovery

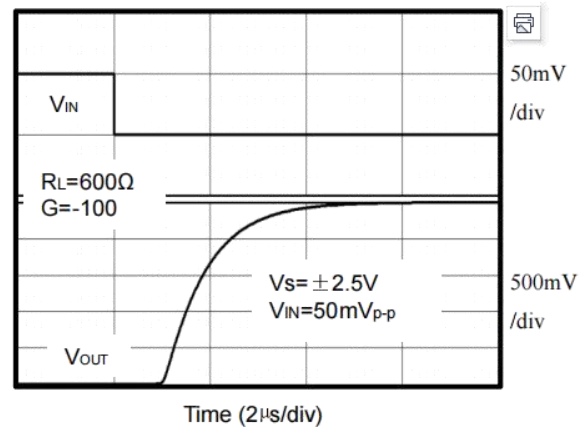

## Typical Performance characteristics

(At  $V_s=5V$ ,  $T_A = +25^\circ C$ ,  $V_{CM} = V_S/2$ ,  $R_L = 600\Omega$ , unless otherwise noted.)

Output Voltage Swing vs. Output Current

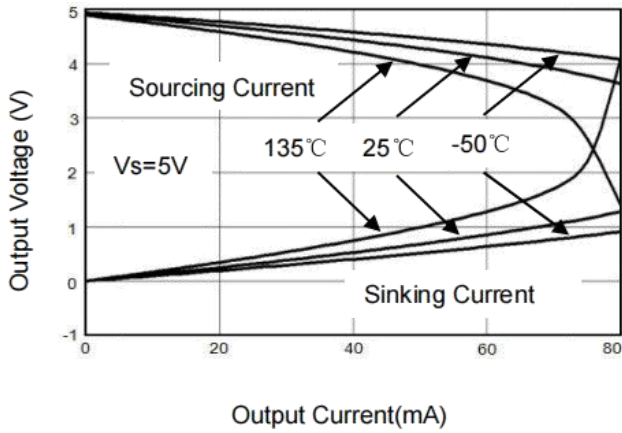

Supply Current vs. Temperature

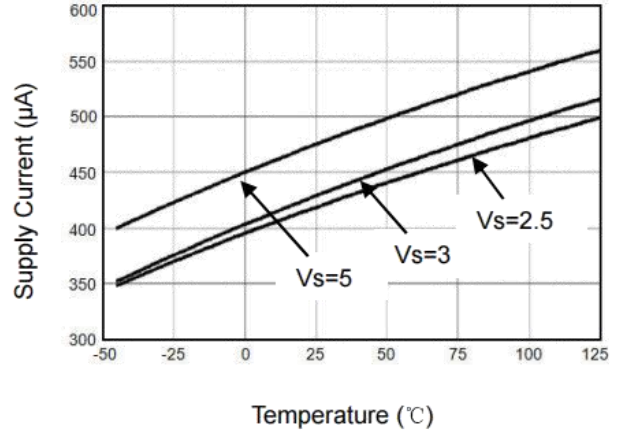

Input Voltage Noise Spectral Density vs. Frequency

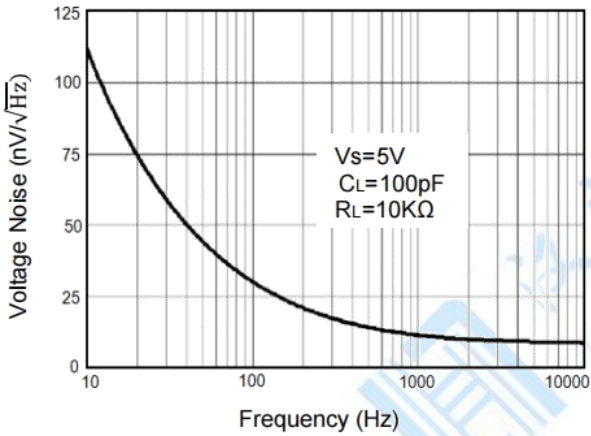

Open Loop Gain, Phase Shift vs. Frequency

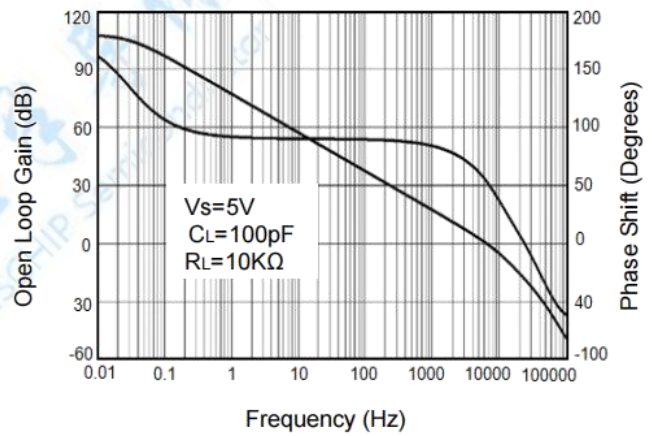

CMRR vs. Frequency

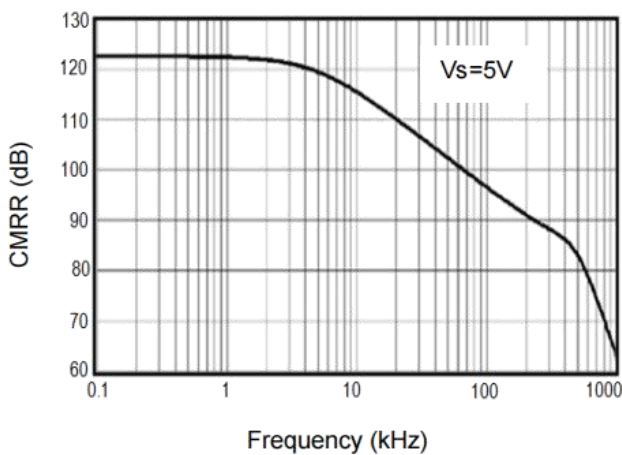

PSRR vs. Frequency

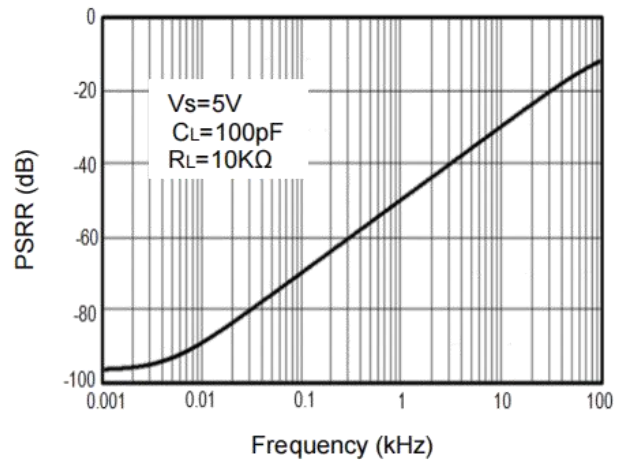

## Application Note

### Size

LMV82X series op amps are unity-gain stable and suitable for a wide range of general-purpose applications. The small footprints of the LMV82X series packages save space on printed circuit boards and enable the design of smaller electronic products.

### Power Supply Bypassing and Board Layout

LMV82X series operates from a single 2.1V to 5.5V supply or dual  $\pm 1.05\text{V}$  to  $\pm 2.75\text{V}$  supplies. For best performance, a  $0.1\mu\text{F}$  ceramic capacitor should be placed close to the VDD pin in single supply operation. For dual supply operation, both VDD and VSS supplies should be bypassed to ground with separate  $0.1\mu\text{F}$  ceramic capacitors.

### Low Supply Current

The low supply current (typical  $470\mu\text{A}$  per channel) of LMV82X series will help to maximize battery life. They are ideal for battery powered systems.

### Operating Voltage

LMV82X series operate under wide input supply voltage (2.1V to 5.5V). In addition, all temperature specifications apply from  $-40\text{ }^{\circ}\text{C}$  to  $+125\text{ }^{\circ}\text{C}$ . Most behavior remains unchanged throughout the full operating voltage range. These guarantees ensure operation throughout the single Li-Ion battery lifetime.

### Rail-to-Rail Input

The input common-mode range of LMV82X series extends  $100\text{mV}$  beyond the supply rails ( $\text{VSS}-0.1\text{V}$  to  $\text{VDD}+0.1\text{V}$ ). This is achieved by using complementary input stage. For normal operation, inputs should be limited to this range.

### Rail-to-Rail Output

Rail-to-Rail output swing provides maximum possible dynamic range at the output. This is particularly important when operating in low supply voltages. The output voltage of LMV82X series can typically swing to less than  $2\text{mV}$  from supply rail in light resistive loads ( $>100\text{k}\Omega$ ), and  $60\text{mV}$  of supply rail in moderate resistive loads ( $10\text{k}\Omega$ ).

### Capacitive Load Tolerance

The LMV82x family is optimized for bandwidth and speed, not for driving capacitive loads. Output capacitance will create a pole in the amplifier's feedback path, leading to excessive peaking and potential oscillation. If dealing with load capacitance is a requirement of the application, the two strategies to consider are (1) using a small resistor in series with the amplifier's output and the load capacitance and (2) reducing the bandwidth of the amplifier's feedback loop by increasing the overall noise gain.

Figure 2. shows a unity gain follower using the series resistor strategy. The resistor isolates the output from the capacitance and, more importantly, creates a zero in the feedback path that compensates for the pole created by the output capacitance.

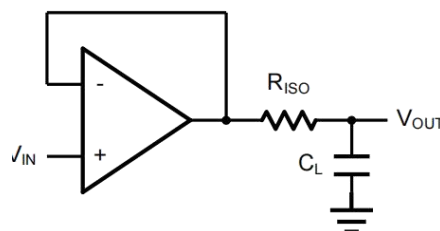

Figure 2. Indirectly Driving a Capacitive Load Using Isolation Resistor

The bigger the RISO resistor value, the more stable VOUT will be. However, if there is a resistive load RL in parallel with the capacitive load, a voltage divider (proportional to RISO/RL) is formed, this will result in a gain error. The circuit in Figure 3 is an improvement to the one in Figure 2. RF provides the DC accuracy by feed-forward the VIN to RL. CF and RISO serve to counteract the loss of phase margin by feeding the high frequency component of the output signal back to the amplifier's inverting input, thereby preserving the phase margin in the overall feedback loop. Capacitive drive can be increased by increasing the value of CF. This in turn will slow down the pulse response.

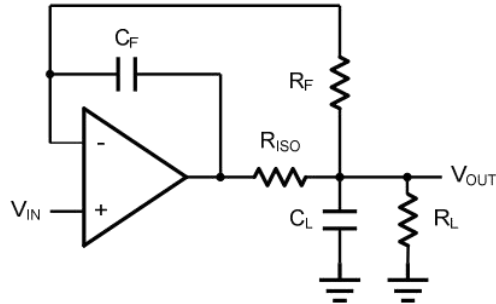

Figure 3. Indirectly Driving a Capacitive Load with DC Accuracy





## Typical Application Circuits

### Differential amplifier

The differential amplifier allows the subtraction of two input voltages or cancellation of a signal common to the two inputs. It is useful as a computational amplifier in making a differential to single-end conversion or in rejecting a common mode signal. Figure 4.

shown the differential amplifier using LMV82X.

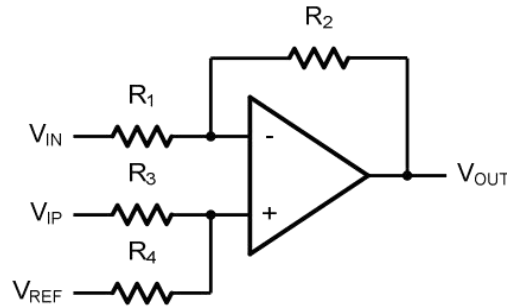

Figure 4. Differential Amplifier

$$V_{OUT} = \left( \frac{R_1 + R_2}{R_3 + R_4} \right) \frac{R_4}{R_1} V_{IN} - \frac{R_2}{R_1} V_{IP} + \left( \frac{R_1 + R_2}{R_3 + R_4} \right) \frac{R_3}{R_1} V_{REF}$$

If the resistor ratios are equal (i.e.  $R_1=R_3$  and  $R_2=R_4$ ), then

$$V_{OUT} = \frac{R_2}{R_1} (V_{IP} - V_{IN}) + V_{REF}$$

### Low Pass Active Filter

The low pass active filter is shown in Figure 5. The DC gain is defined by  $-R_2/R_1$ . The filter has a  $-20\text{dB/decade}$  roll-off after its corner frequency  $f_C=1/(2\pi R_3 C_1)$ .

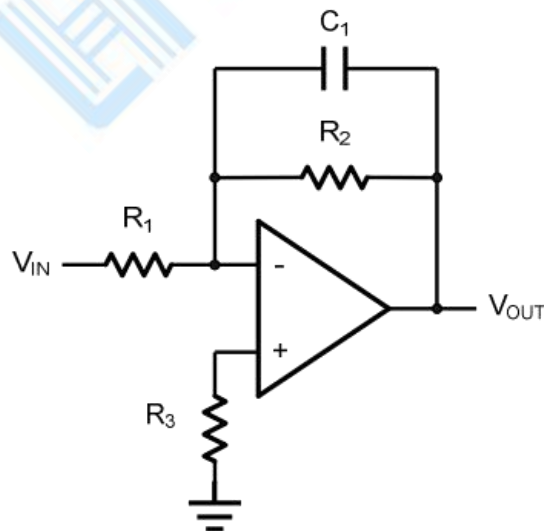

Figure 5. Low Pass Active Filter

## Instrumentation Amplifier

The triple LMV82X can be used to build a three-op-amp instrumentation amplifier as shown in Figure 6. The amplifier in Figure 6 is a high input impedance differential amplifier with gain of  $R_2/R_1$ . The two differential voltage followers assure the high input impedance of the amplifier.

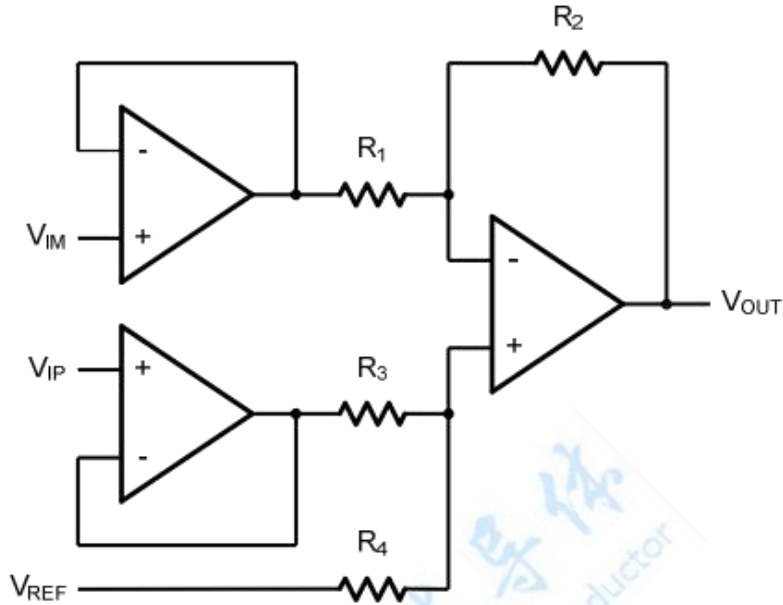
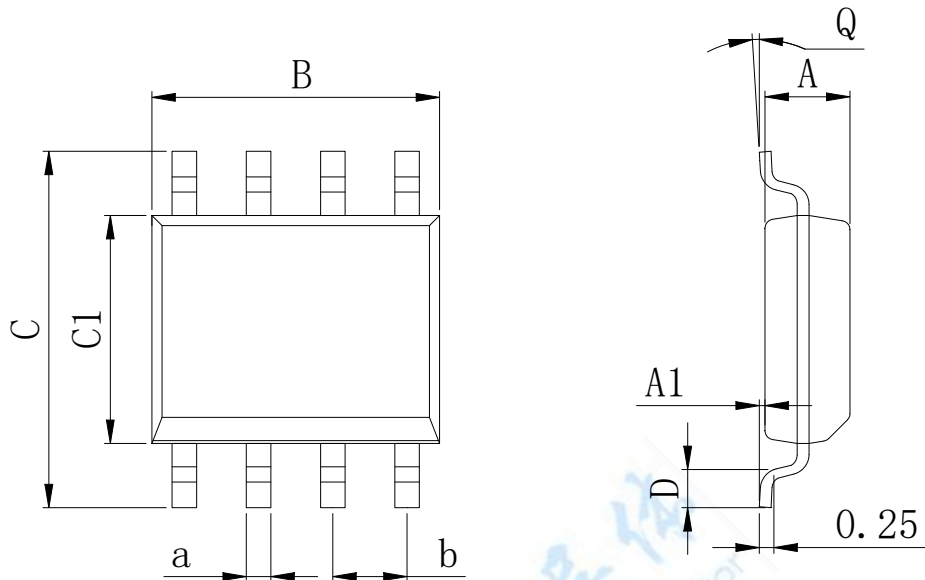

Figure 6. Instrument Amplifier

## Physical Dimensions

SOP8 (150mil)



Dimensions In Millimeters(SOP8)

Symbol:	A	A1	B	C	C1	D	Q	a	b
Min:	1.35	0.05	4.90	5.80	3.80	0.40	0°	0.35	1.27 BSC
Max:	1.55	0.20	5.10	6.20	4.00	0.80	8°	0.45	

MSOP8

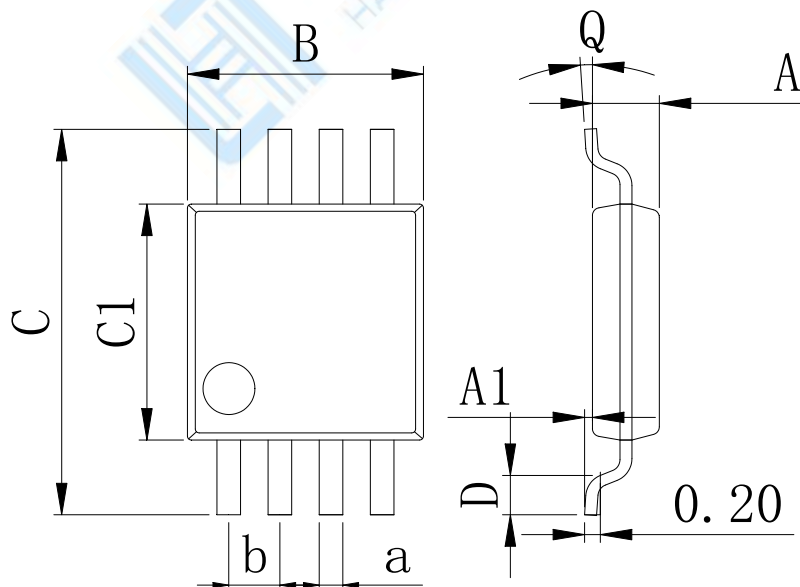

Dimensions In Millimeters(MSOP8)

Symbol:	A	A1	B	C	C1	D	Q	a	b
Min:	0.80	0.05	2.90	4.75	2.90	0.35	0°	0.25	0.65 BSC
Max:	0.90	0.20	3.10	5.05	3.10	0.75	8°	0.35	

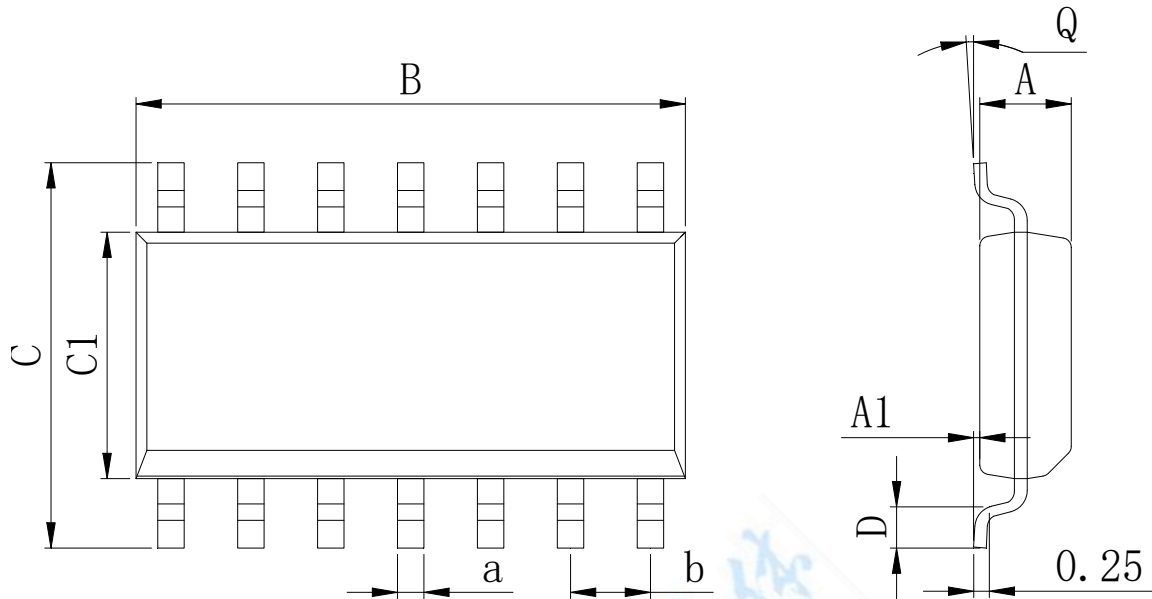
**Physical Dimensions**
**SOP14**

**Dimensions In Millimeters(SOP14)**

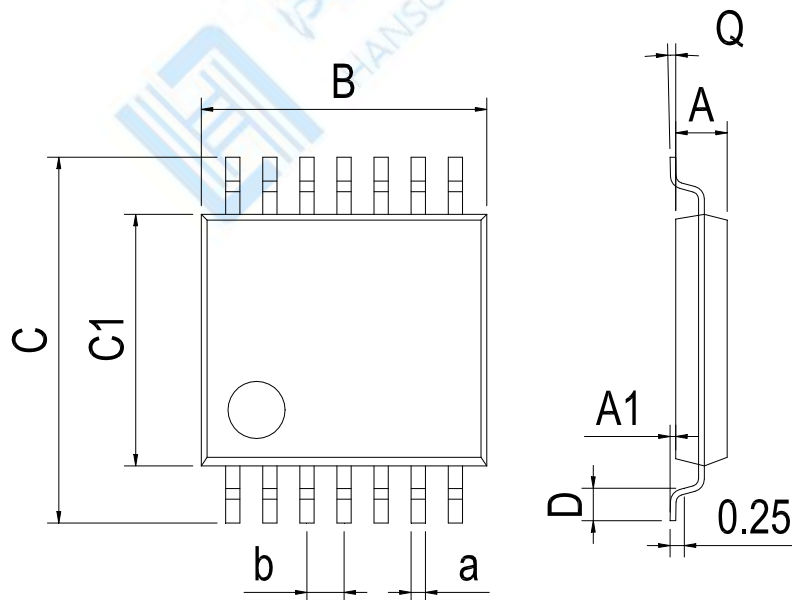
Symbol:	A	A1	B	C	C1	D	Q	a	b
Min:	1.35	0.05	8.55	5.80	3.80	0.40	0°	0.35	1.27 BSC
Max:	1.55	0.20	8.75	6.20	4.00	0.80	8°	0.45	

**TSSOP14**

**Dimensions In Millimeters(TSSOP14)**

Symbol:	A	A1	B	C	C1	D	Q	a	b
Min:	0.85	0.05	4.90	6.20	4.30	0.40	0°	0.20	0.65 BSC
Max:	0.95	0.20	5.10	6.60	4.50	0.80	8°	0.25	

**Physical Dimensions**

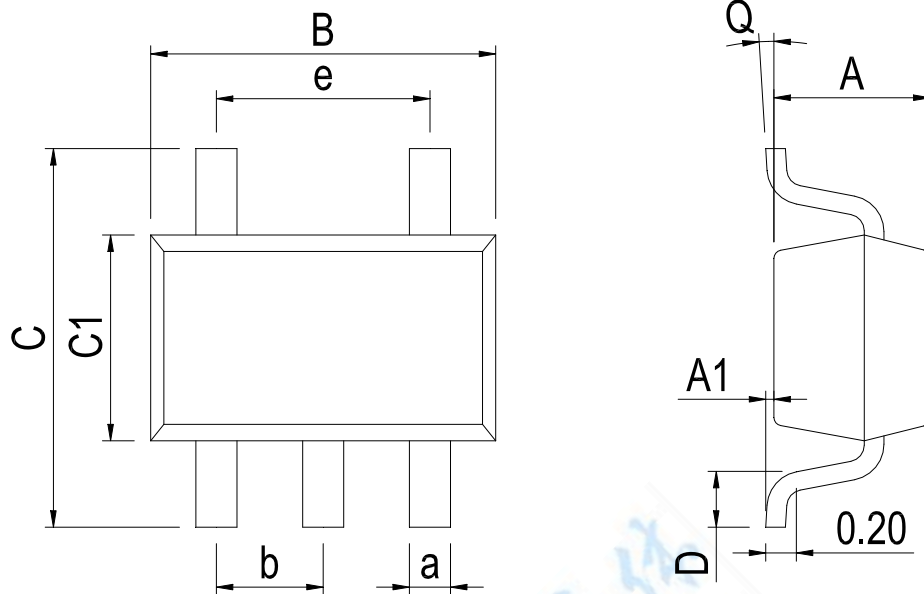
SOT23-5

**Dimensions In Millimeters(SOT23-5)**

Symbol:	A	A1	B	C	C1	D	Q	a	b	e
Min:	1.05	0.00	2.82	2.65	1.50	0.30	0°	0.30	0.95 BSC	1.90 BSC
Max:	1.15	0.15	3.02	2.95	1.70	0.60	8°	0.40		

SC70-5

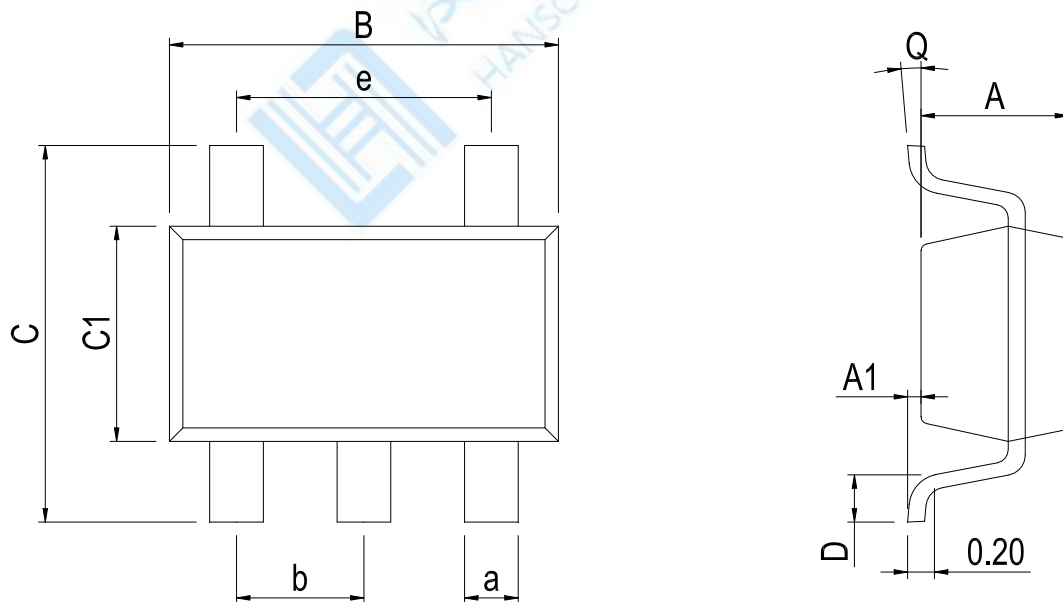
**Dimensions In Millimeters(SC70-5)**

Symbol:	A	A1	B	C	C1	D	Q	a	b	e
Min:	0.90	0.00	2.00	2.15	1.15	0.26	0°	0.30	0.65	1.30 BSC
Max:	1.00	0.15	2.20	2.45	1.35	0.46	8°	0.40	BSC	

**IMPORTANT STATEMENT:**

**Shenzhen Hanschip semiconductor co.,ltd. reserves the right to change the products and services provided without notice. Customers should obtain the latest relevant information before ordering, and verify the timeliness and accuracy of this information.**

**Customers are responsible for complying with safety standards and taking safety measures when using our products for system design and machine manufacturing to avoid potential risks that may result in personal injury or property damage.**

**Our products are not licensed for applications in life support, military, aerospace, etc., so we do not bear the consequences of the application of these products in these fields.**

**Our documentation is only permitted to be copied without any tampering with the content, so we do not accept any responsibility or liability for the altered documents.**



## X-ON Electronics

Largest Supplier of Electrical and Electronic Components

*Click to view similar products for [Operational Amplifiers - Op Amps](#) category:*

*Click to view products by [Analog Devices](#) manufacturer:*

Other Similar products are found below :

[430227FB](#) [LT1678IS8](#) [NCV33202DMR2G](#) [NJM324E](#) [M38510/13101BPA](#) [NTE925](#) [AZV358MTR-G1](#) [AP4310AUMTR-AG1](#)  
[AZV358MMTR-G1](#) [SCY33178DR2G](#) [NCV20034DR2G](#) [NTE778S](#) [NTE871](#) [NTE937](#) [NJU7057RB1-TE2](#) [SCY6358ADR2G](#)  
[NJM2904CRB1-TE1](#) [UPC4570G2-E1-A](#) [UPC4741G2-E1-A](#) [NJM8532RB1-TE1](#) [EL2250CS](#) [EL5100IS](#) [EL5104IS](#) [EL5127CY](#) [EL5127CZY](#)  
[EL5133IW](#) [EL5152IS](#) [EL5156IS](#) [EL5162IS](#) [EL5202IY](#) [EL5203IY](#) [EL5204IY](#) [EL5210CS](#) [EL5210CZY](#) [EL5211IYE](#) [EL5220CY](#)  
[EL5223CLZ](#) [EL5223CR](#) [EL5224ILZ](#) [EL5227CLZ](#) [EL5227CRZ](#) [EL5244CS](#) [EL5246CS](#) [EL5246CSZ](#) [EL5250IY](#) [EL5251IS](#) [EL5257IS](#)  
[EL5260IY](#) [EL5261IS](#) [EL5300IU](#)