

Picoamp Input Current, Microvolt Offset, Low Noise Op Amp

FEATURES

- Guaranteed Bias Current
 $T_A = 25^\circ\text{C}$: 100pA Max
 $T_A = -55^\circ\text{C}$ to 125°C : 600pA Max
- Guaranteed Offset Voltage: 120 μV Max
- Guaranteed Drift: 1.5 $\mu\text{V}/^\circ\text{C}$ Max
- Low Noise, 0.1Hz to 10Hz: 0.5 $\mu\text{V}_{\text{P-P}}$
- Guaranteed Low Supply Current: 600 μA Max
- Guaranteed CMRR: 114dB Min
- Guaranteed PSRR: 114dB Min
- Guaranteed Voltage Gain with 5mA Load Current
- Available in 8-Lead PDIP and SO Packages

APPLICATIONS

- Precision Instrumentation
- Charge Integrators
- Wide Dynamic Range Logarithmic Amplifiers
- Light Meters
- Low Frequency Active Filters
- Standard Cell Buffers
- Thermocouple Amplifiers

DESCRIPTION

The LT[®]1008 is a universal precision operational amplifier that can be used in practically all precision applications. The LT1008 combines for the first time, picoampere bias currents (which are maintained over the full -55°C to 125°C temperature range), microvolt offset voltage (and low drift with time and temperature), low voltage and current noise, and low power dissipation. Extremely high common mode and power supply rejection ratios, and the ability to deliver 5mA load current with high voltage gain round out the LT1008's superb precision specifications.

The all around excellence of the LT1008 eliminates the necessity of the time consuming error analysis procedure of precision system design in many applications; the LT1008 can be stocked as the universal precision op amp.

The LT1008 is externally compensated with a single capacitor for additional flexibility in shaping the frequency response of the amplifier. It plugs into and upgrades all standard LM108A/LM308A applications. For an internally compensated version with even lower offset voltage but otherwise similar performance see the LT1012.

LT, LT, LTC and LTM are registered trademarks of Linear Technology Corporation.

TYPICAL APPLICATION

Input Amplifier for 4.5 Digit Voltmeter

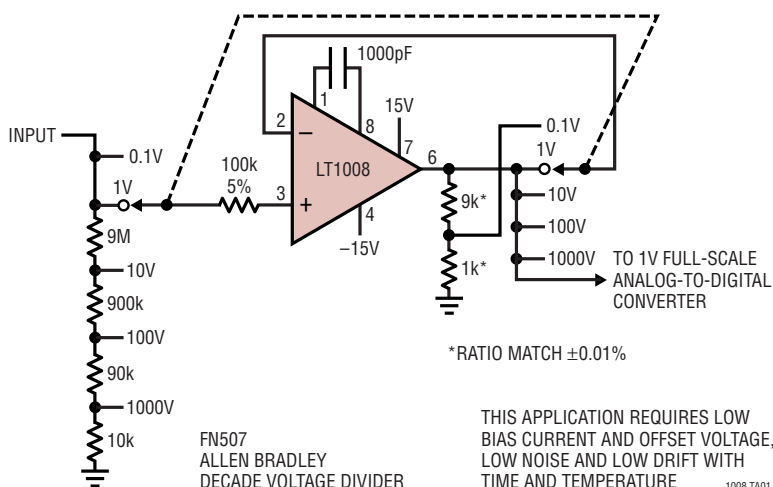

Input Bias Current vs Temperature

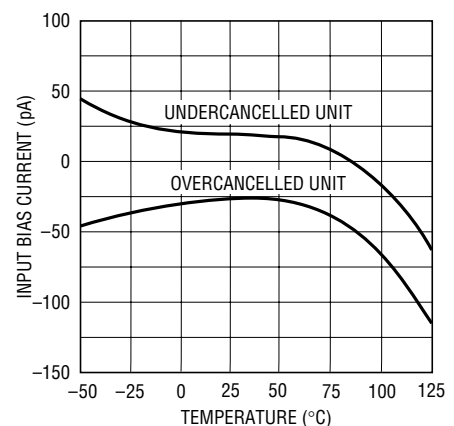

1008 TA02

LT1008

ABSOLUTE MAXIMUM RATINGS (Note 1)

| | | | |
|---|--|--|--|
| Supply Voltage | $\pm 20\text{V}$ | Operating Temperature Range | |
| Differential Input Current (Note 2) | $\pm 10\text{mA}$ | LT1008M (OBSOLETE) | -55°C to 125°C |
| Input Voltage | $\pm 20\text{V}$ | LT1008C | 0°C to 70°C |
| Output Short-Circuit Duration | Indefinite | LT1008I | -40°C to 85°C |
| Storage Temperature Range | -65°C to 150°C | Lead Temperature (Soldering, 10 sec) | 300°C |

PACKAGE/ORDER INFORMATION

| | | | | |
|---|--|--|--|------------------------------------|
| <p>TOP VIEW COMP2 COMP1 -IN +IN V⁻ (CASE) H PACKAGE 8-LEAD TO-5 METAL CAN $T_{JMAX} = 150^{\circ}\text{C}$, $\theta_{JA} = 150^{\circ}\text{C/W}$, $\theta_{JC} = 45^{\circ}\text{C/W}$</p> | <p>TOP VIEW COMP1 -IN +IN V⁻ N8 PACKAGE 8-LEAD PDIP $T_{JMAX} = 150^{\circ}\text{C}$, $\theta_{JA} = 130^{\circ}\text{C/W}$</p> | <p>TOP VIEW COMP1 -IN +IN V⁻ S8 PACKAGE 8-LEAD PLASTIC SO $T_{JMAX} = 150^{\circ}\text{C}$, $\theta_{JA} = 190^{\circ}\text{C/W}$</p> | | |
| <p>ORDER PART NUMBER</p> <p>LT1008MH LT1008CH</p> <p>OBSOLETE PACKAGES Consider N8 or S8 Package for Alternate Source</p> | <p>ORDER PART NUMBER</p> <p>LT1008MJ8 LT1008CJ8</p> | <p>ORDER PART NUMBER</p> <p>LT1008CN8 LT1008IN8</p> | <p>ORDER PART NUMBER</p> <p>LT1008S8</p> | <p>S8 PART MARKING</p> <p>1008</p> |
| <p>Order Options Tape and Reel: Add #TR Lead Free: Add #PBF Lead Free Tape and Reel: Add #TRPBF Lead Free Part Marking: http://www.linear.com/leadfree/</p> | | | | |

Consult LTC Marketing for parts specified with wider operating temperature ranges.

ELECTRICAL CHARACTERISTICS $V_S = \pm 15\text{V}$, $V_{CM} = 0\text{V}$, $T_A = 25^{\circ}\text{C}$, unless otherwise noted.

| SYMBOL | PARAMETER | CONDITIONS | LT1008M/I | | | LT1008C | | | UNITS |
|-----------|--|--|-----------|-----------|-----|----------|-----------|-----|--|
| | | | MIN | TYP | MAX | MIN | TYP | MAX | |
| V_{OS} | Input Offset Voltage | (Note 3) | 30 | 120 | | 30 | 120 | | μV |
| | Long-Term Input Offset Voltage Stability | | 40 | 180 | | 40 | 180 | | $\mu\text{V}/\text{Month}$ |
| I_{OS} | Input Offset Current | (Note 3) | 30 | 100 | | 30 | 100 | | pA |
| | | | 40 | 150 | | 40 | 150 | | pA |
| I_B | Input Bias Current | (Note 3) | ± 30 | ± 100 | | ± 30 | ± 100 | | pA |
| | | | ± 40 | ± 150 | | ± 40 | ± 150 | | pA |
| e_n | Input Noise Voltage | 0.1Hz to 10Hz | 0.5 | | | 0.5 | | | μV_{P-P} |
| | Input Noise Voltage Density | $f_0 = 10\text{Hz}$ (Note 4) $f_0 = 1000\text{Hz}$ (Note 5) | 17 | 30 | | 17 | 30 | | $\text{nV}/\sqrt{\text{Hz}}$ $\text{nV}/\sqrt{\text{Hz}}$ |
| i_n | Input Noise Current Density | $f_0 = 10\text{Hz}$ | 20 | | | 20 | | | $\text{fA}/\sqrt{\text{Hz}}$ |
| A_{VOL} | Large-Signal Voltage Gain | $V_{OUT} = \pm 12\text{V}$, $R_L \geq 10\text{k}$ | 200 | 2000 | | 200 | 2000 | | V/mV |
| | | $V_{OUT} = \pm 10\text{V}$, $R_L \geq 2\text{k}$ | 120 | 600 | | 120 | 600 | | V/mV |

1008fb

ELECTRICAL CHARACTERISTICS $V_S = \pm 15V$, $V_{CM} = 0V$, $T_A = 25^\circ C$, unless otherwise noted.

| SYMBOL | PARAMETER | CONDITIONS | LT1008M/I | | | LT1008C | | | UNITS |
|-----------|------------------------------|-----------------------------|------------|----------|-----|------------|----------|-----|------------|
| | | | MIN | TYP | MAX | MIN | TYP | MAX | |
| CMRR | Common Mode Rejection Ratio | $V_{CM} = \pm 13.5V$ | 114 | 132 | | 114 | 132 | | dB |
| PSRR | Power Supply Rejection Ratio | $V_S = \pm 2V$ to $\pm 20V$ | 114 | 132 | | 114 | 132 | | dB |
| | Input Voltage Range | | ± 13.5 | ± 14 | | ± 13.5 | ± 14 | | V |
| V_{OUT} | Output Voltage Swing | $R_L = 10k$ | ± 13 | ± 14 | | ± 13 | ± 14 | | V |
| | Slew Rate | $C_F = 30pF$ | 0.1 | 0.2 | | 0.1 | 0.2 | | V/ μs |
| I_S | Supply Current | (Note 3) | | 380 | 600 | | 380 | 600 | μA |

The ● indicates specifications which apply over the full operating temperature range of $-55^\circ C \leq T_A \leq 125^\circ C$ for the LT1008M, $-40^\circ C \leq T_A \leq 85^\circ C$ for the LT1008I and $0^\circ C \leq T_A \leq 70^\circ C$ for the LT1008C. $V_S = \pm 15V$, $V_{CM} = 0V$, unless otherwise noted.

| SYMBOL | PARAMETER | CONDITIONS | LT1008M/I | | | LT1008C | | | UNITS |
|-----------|---|--------------------------------------|-----------|------------|-----------|---------|------------|-----------|------------------|
| | | | MIN | TYP | MAX | MIN | TYP | MAX | |
| V_{OS} | Input Offset Voltage | (Note 3) | ● | 50 | 250 | | 40 | 180 | μV |
| | | | ● | 60 | 320 | | 50 | 250 | μV |
| | Average Temperature Coefficient of Input Offset Voltage | | ● | 0.2 | 1.5 | | 0.2 | 1.5 | $\mu V/^\circ C$ |
| I_{OS} | Input Offset Current | (Note 3) | ● | 60 | 250 | | 40 | 180 | pA |
| | | | ● | 80 | 350 | | 50 | 250 | pA |
| | Average Temperature Coefficient of Input Offset Current | | ● | 0.4 | 2.5 | | 0.4 | 2.5 | pA/ $^\circ C$ |
| I_B | Input Bias Current | (Note 3) | ● | ± 80 | ± 600 | | ± 40 | ± 180 | pA |
| | | | ● | ± 150 | ± 800 | | ± 50 | ± 250 | pA |
| | Average Temperature Coefficient of Input Bias Current | | ● | 0.6 | 6 | | 0.4 | 2.5 | pA/ $^\circ C$ |
| A_{VOL} | Large-Signal Voltage Gain | $V_{OUT} = \pm 12V$, $R_L \geq 10k$ | ● | 100 | 1000 | | 150 | 1500 | V/mV |
| CMRR | Common Mode Rejection Ratio | $V_{CM} = \pm 13.5V$ | ● | 108 | 128 | | 110 | 130 | dB |
| PSRR | Power Supply Rejection Ratio | $V_S = \pm 2.5V$ to $\pm 20V$ | ● | 108 | 126 | | 110 | 128 | dB |
| | Input Voltage Range | | ● | ± 13.5 | | | ± 13.5 | | V |
| V_{OUT} | Output Voltage Swing | $R_L = 10k$ | ● | ± 13 | ± 14 | | ± 13 | ± 14 | V |
| I_S | Supply Current | | ● | 400 | 800 | | 400 | 800 | μA |

(LT1008S8 only) $V_S = \pm 15V$, $V_{CM} = 0V$, $T_A = 25^\circ C$, unless otherwise noted.

| SYMBOL | PARAMETER | CONDITIONS | MIN | TYP | MAX | UNITS |
|----------|--|--|-----|-----------|-----------|-----------------|
| V_{OS} | Input Offset Voltage | (Note 3) | | 30 | 200 | μV |
| | | | | 40 | 250 | μV |
| | Long-Term Input Offset Voltage Stability | | | 0.3 | | $\mu V/$ Month |
| I_{OS} | Input Offset Current | (Note 3) | | 100 | 280 | pA |
| | | | | 120 | 380 | pA |
| I_B | Input Bias Current | (Note 3) | | ± 100 | ± 300 | pA |
| | | | | ± 120 | ± 400 | pA |
| e_n | Input Noise Voltage | 0.1Hz to 10Hz | | 0.5 | | μV_{P-P} |
| | Input Noise Voltage Density | $f_0 = 10Hz$ (Note 5) $f_0 = 1000Hz$ (Note 5) | | 17 | 30 | nV/ \sqrt{Hz} |
| | | | | 14 | 22 | nV/ \sqrt{Hz} |

ELECTRICAL CHARACTERISTICS (LT1008S8 only) $V_S = \pm 15V$, $V_{CM} = 0V$, $T_A = 25^\circ C$, unless otherwise noted.

| SYMBOL | PARAMETER | CONDITIONS | MIN | TYP | MAX | UNITS |
|-----------|------------------------------|---|------------|-------------|-----|-----------------|
| i_n | Input Noise Current Density | $f_0 = 10Hz$ | | 20 | | fA/ \sqrt{Hz} |
| A_{VOL} | Large-Signal Voltage Gain | $V_{OUT} = \pm 12V, R_L \geq 10k$ $V_{OUT} = \pm 10V, R_L \geq 2k$ | 200 120 | 2000 600 | | V/mV V/mV |
| CMRR | Common Mode Rejection Ratio | $V_{CM} = \pm 13.5V$ | 110 | 132 | | dB |
| PSRR | Power Supply Rejection Ratio | $V_S = \pm 2V$ to $\pm 20V$ | 110 | 132 | | dB |
| | Input Voltage Range | | ± 13.5 | ± 14 | | V |
| V_{OUT} | Output Voltage Swing | $R_L = 10k$ | ± 13 | ± 14 | | V |
| | Slew Rate | $C_F = 30pF$ | 0.1 | 0.2 | | V/ μs |
| I_S | Supply Current | (Note 3) | | 380 | 600 | μA |

(LT1008S8 only) The ● indicates specifications which apply over the full operating temperature range of $0^\circ C \leq T_A \leq 70^\circ C$. $V_S = \pm 15V$, $V_{CM} = 0V$, unless otherwise noted.

| SYMBOL | PARAMETER | CONDITIONS | MIN | TYP | MAX | UNITS |
|-----------|---|-----------------------------------|-----|------------|-----------|------------------|
| V_{OS} | Input Offset Voltage | (Note 3) | ● | 40 | 280 | μV |
| | | | ● | 50 | 340 | μV |
| | Average Temperature Coefficient of Input Offset Voltage | | ● | 0.2 | 1.8 | $\mu V/^\circ C$ |
| I_{OS} | Input Offset Current | (Note 3) | ● | 120 | 380 | pA |
| | | | ● | 140 | 500 | pA |
| | Average Temperature Coefficient of Input Offset Current | | ● | 0.4 | 4 | pA/ $^\circ C$ |
| I_B | Input Bias Current | (Note 3) | ● | ± 120 | ± 420 | pA |
| | | | ● | ± 140 | ± 550 | pA |
| | Average Temperature Coefficient of Input Bias Current | | ● | 0.4 | 5 | pA/ $^\circ C$ |
| A_{VOL} | Large-Signal Voltage Gain | $V_{OUT} = \pm 12V, R_L \geq 10k$ | ● | 150 | 1500 | V/mV |
| CMRR | Common Mode Rejection Ratio | $V_{CM} = \pm 13.5V$ | ● | 108 | 130 | dB |
| PSRR | Power Supply Rejection Ratio | $V_S = \pm 2.5V$ to $\pm 20V$ | ● | 108 | 128 | dB |
| | Input Voltage Range | | ● | ± 13.5 | | V |
| V_{OUT} | Output Voltage Swing | $R_L = 10k$ | ● | ± 13 | ± 14 | V |
| I_S | Supply Current | | ● | 400 | 800 | μA |

Note 1: Stresses beyond those listed under Absolute Maximum Ratings may cause permanent damage to the device. Exposure to any Absolute Maximum Rating condition for extended periods may affect device reliability and lifetime.

Note 2: Differential input voltages greater than 1V will cause excessive current to flow through the input protection diodes unless current limiting resistors are used.

Note 3: These specifications apply for $\pm 2V \leq V_S \leq \pm 20V$ ($\pm 2.5V \leq V_S \leq \pm 20V$ over the temperature range) and $-13.5V \leq V_{CM} \leq 13.5V$ (for $V_S = \pm 15V$).

Note 4: 10Hz noise voltage density is sample tested on every lot. Devices 100% tested at 10Hz are available on request.

Note 5: This parameter is tested on a sample basis only.

FREQUENCY COMPENSATION CIRCUITS

Standard Compensation Circuit

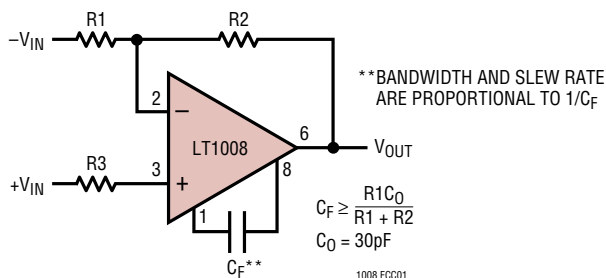

Alternate* Frequency Compensation

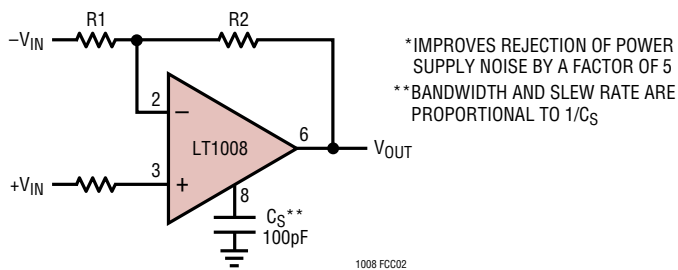

FOR $\frac{R_2}{R_1} > 200$, NO EXTERNAL FREQUENCY COMPENSATION IS NECESSARY

TYPICAL PERFORMANCE CHARACTERISTICS

Offset Voltage Drift vs Source Resistance (Balanced or Unbalanced)

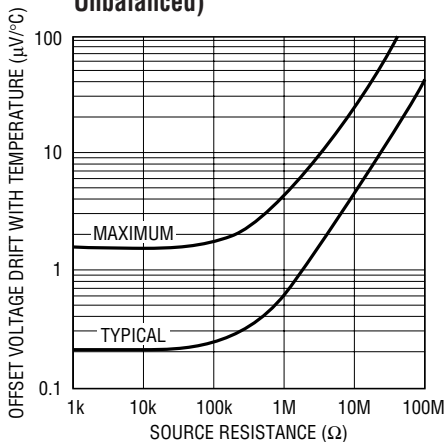

Offset Voltage vs Source Resistance (Balanced or Unbalanced)

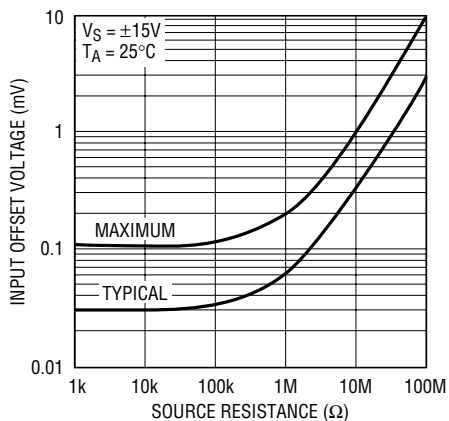

Input Bias Current vs Common Mode Range

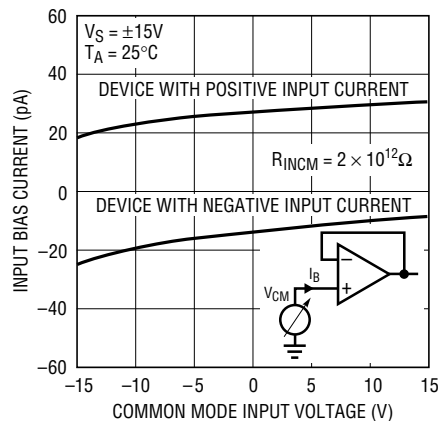

Warm-Up Drift

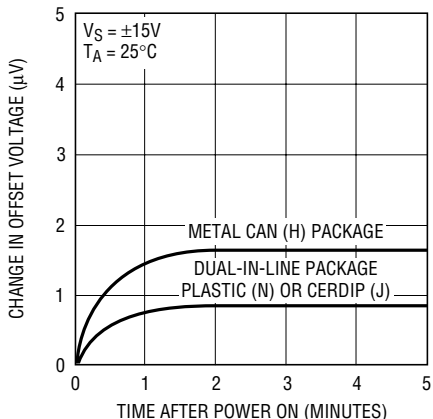

Long-Term Stability of Four Representative Units

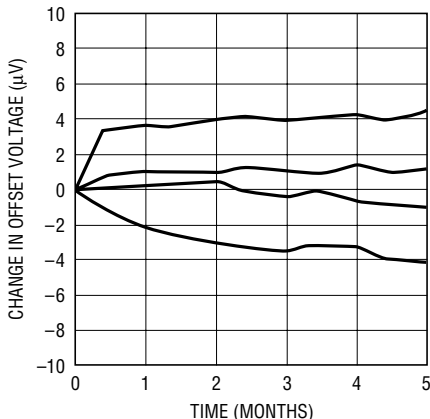

Offset Voltage Drift with Temperature of Four Representative Units

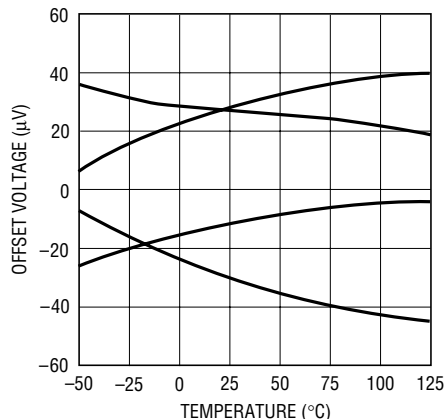

TYPICAL PERFORMANCE CHARACTERISTICS

Supply Current vs Supply Voltage

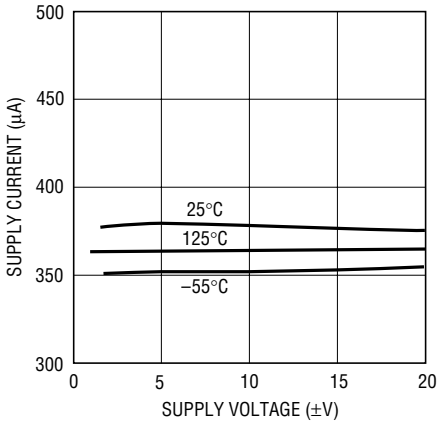

1008 G07

Output Short-Circuit Current vs Time

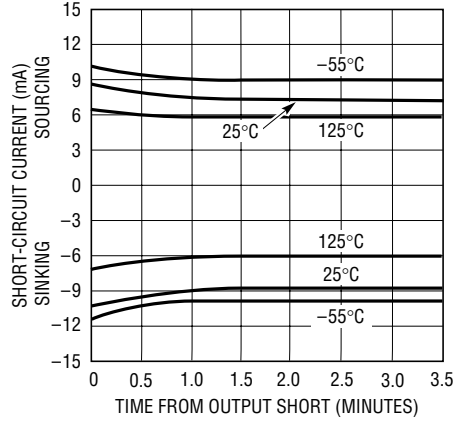

1008 G08

0.1Hz to 10Hz Noise

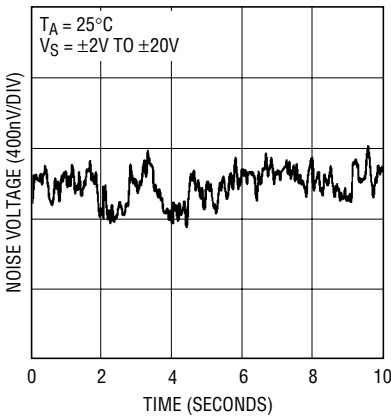

1008 G09

Noise Spectrum

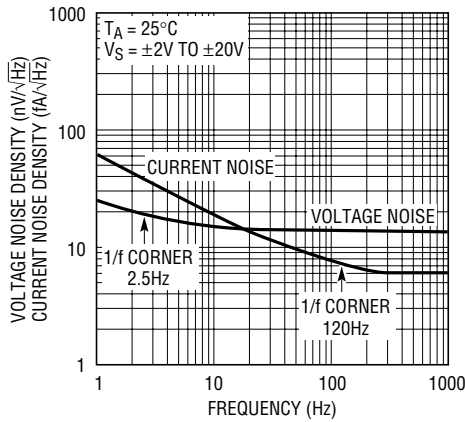

1008 G10

Total Noise vs Source Resistance

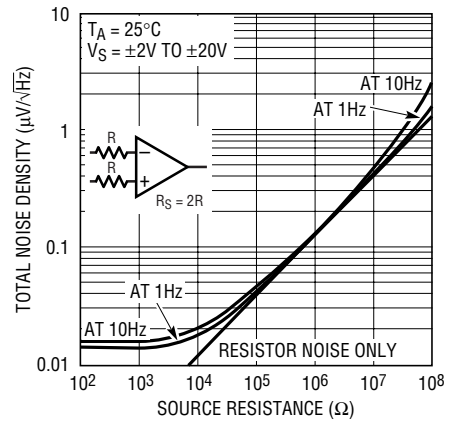

1008 G11

Voltage Gain vs Frequency

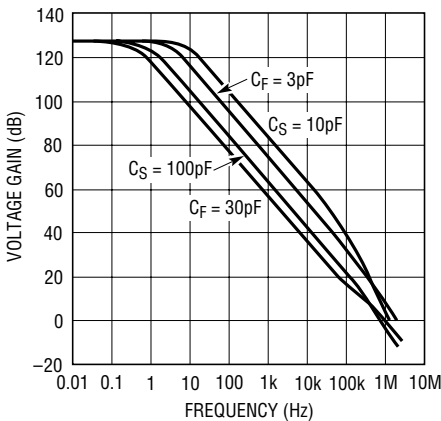

1008 G12

Gain, Phase Shift vs Frequency with Alternate Compensation

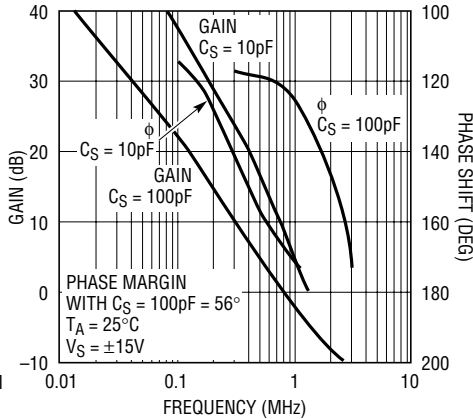

1008 G13

Gain, Phase Shift vs Frequency with Standard (Feedback) Compensation

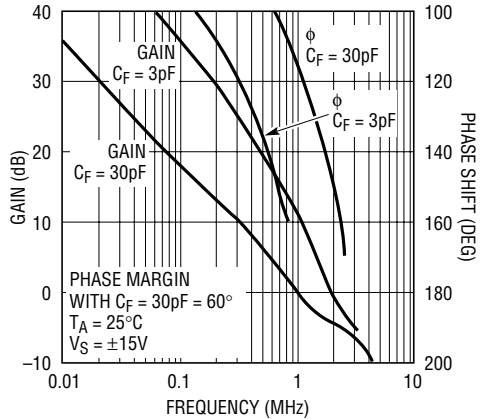

1008 G14

TYPICAL PERFORMANCE CHARACTERISTICS

Voltage Gain vs Load Resistance

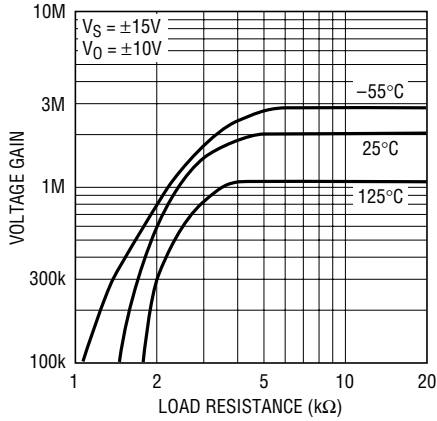

Common Mode Rejection vs Frequency

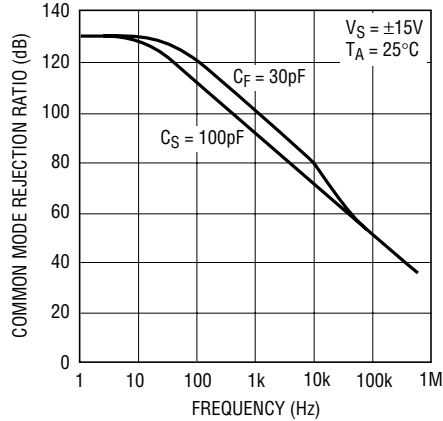

Power Supply Rejection vs Frequency

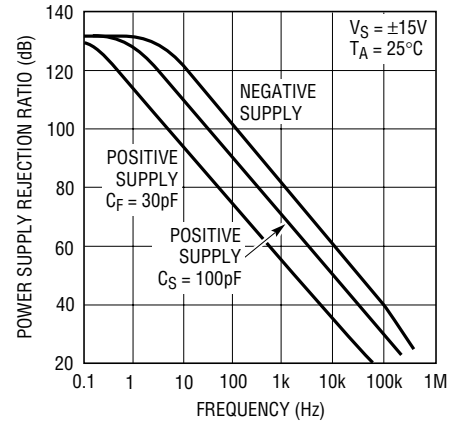

Large-Signal Transient Response

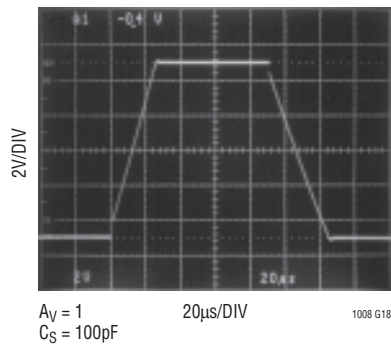

Slew Rate vs Compensation Capacitance

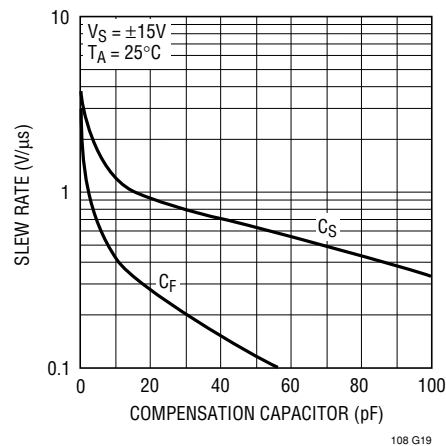

Large-Signal Transient Response

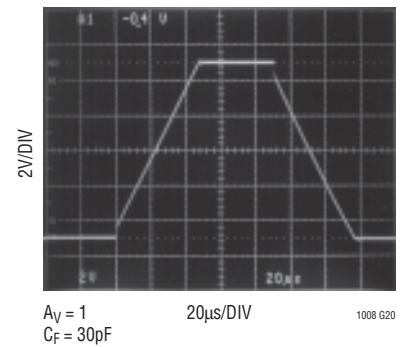

Small-Signal Transient Response

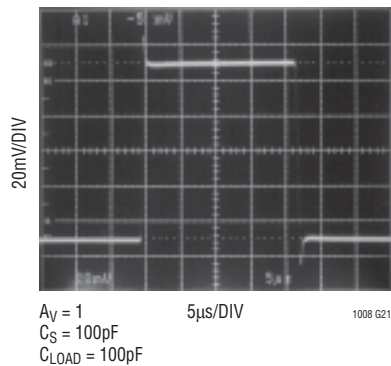

Small-Signal Transient Response

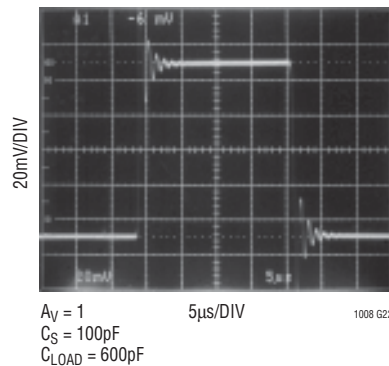

Small-Signal Transient Response

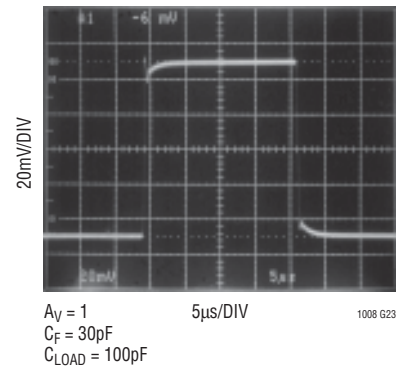

APPLICATIONS INFORMATION

Achieving Picoampere/Microvolt Performance

In order to realize the picoampere—microvolt level accuracy of the LT1008, proper care must be exercised. For example, leakage currents in circuitry external to the op amp can significantly degrade performance. High quality insulation should be used (e.g., Teflon™, Kel-F); cleaning of all insulating surfaces to remove fluxes and other residues will probably be required. Surface coating may be necessary to provide a moisture barrier in high humidity environments.

Board leakage can be minimized by encircling the input circuitry with a guard ring operated at a potential close to that of the inputs: in inverting configurations the guard ring should be tied to ground, in noninverting connections to the inverting input at Pin 2. Guarding both sides of the printed circuit board is required. Bulk leakage reduction depends on the guard ring width. Nanoampere level leakage into the compensation terminals can affect offset voltage and drift with temperature.

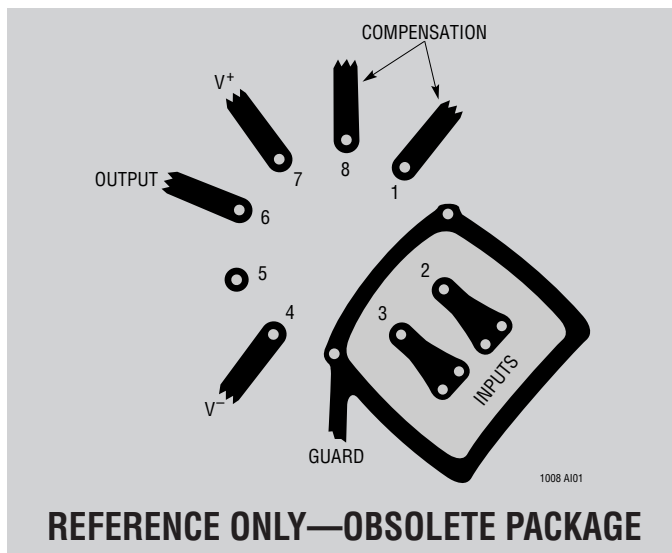

Microvolt level error voltages can also be generated in the external circuitry. Thermocouple effects caused by temperature gradients across dissimilar metals at the contacts to the input terminals can exceed the inherent drift of the amplifier. Air currents over device leads should be minimized, package leads should be short, and the two input leads should be as close together as possible and maintained at the same temperature.

The LT1008 is specified over a wide range of power supply voltages from ±2V to ±18V. Operation with lower supplies is possible down to ±1.2V (two Ni-Cad batteries).

Test Circuit for Offset Voltage and Its Drift with Temperature

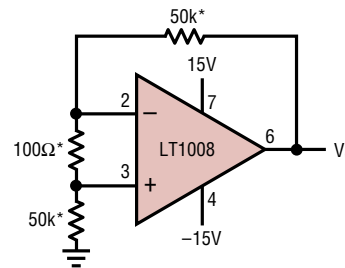

* RESISTORS MUST HAVE LOW THERMOELECTRIC POTENTIAL
THIS CIRCUIT IS ALSO USED AS THE BURN-IN CONFIGURATION FOR THE LT1008 WITH SUPPLY VOLTAGES INCREASED TO ±20V
V_O = 1000V_{OS}

1008 AI02

Noise Testing

The 0.1Hz to 10Hz peak-to-peak noise of the LT1008 is measured in the test circuit shown. The frequency response of this noise tester indicates that the 0.1Hz corner is defined by only one zero. The test time to measure 0.1Hz to 10Hz noise should not exceed 10 seconds, as this time limit acts as an additional zero to eliminate noise contributions from the frequency band below 0.1Hz.

A noise voltage density test is recommended when measuring noise on a large number of units. A 10Hz noise voltage density measurement will correlate well with a 0.1Hz to 10Hz peak-to-peak noise reading since both results are determined by the white noise and the location of the 1/f corner frequency.

Current noise is measured in the circuit shown and calculated by the following formula where the noise of the source resistors is subtracted.

$$i_n = \frac{[e^2_{no} - (820nV)^2]^{1/2}}{40M\Omega \times 100}$$

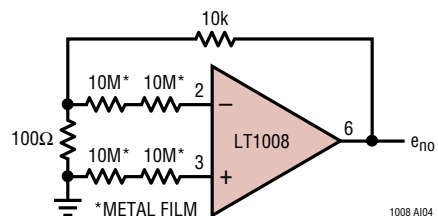

1008 AI04

APPLICATIONS INFORMATION

0.1Hz to 10Hz Noise Test Circuit

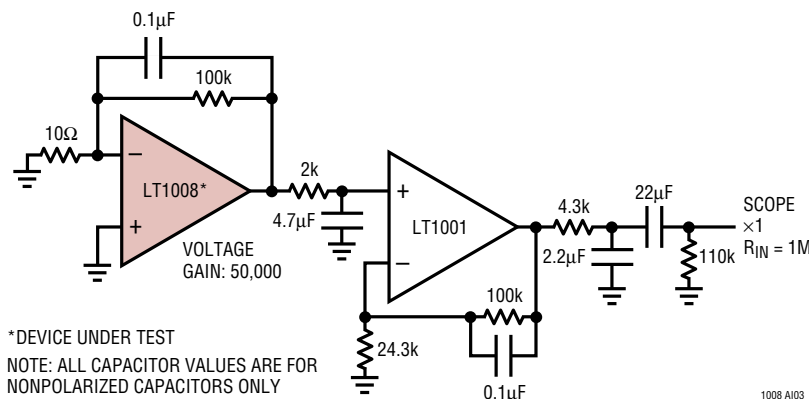

Frequency Compensation

The LT1008 is externally frequency compensated with a single capacitor. The two standard compensation circuits shown earlier are identical to the LM108A/LM308A frequency compensation schemes. Therefore, the LT1008 operational amplifiers can be inserted directly into LM108A/LM308A sockets, with similar AC and upgraded DC performance.

External frequency compensation provides the user with additional flexibility in shaping the frequency response of the amplifier. For example, for a voltage gain of ten and $C_F = 3\text{pF}$, a gain bandwidth product of 5MHz and slew rate of $1.2\text{V}/\mu\text{s}$ can be realized. For closed-loop gains in excess of 200, no external compensation is necessary, and slew rate increases to $4\text{V}/\mu\text{s}$. The LT1008 can also be overcompensated (i.e., $C_F > 30\text{pF}$ or $C_S > 100\text{pF}$) to improve capacitive load handling capability or to narrow noise bandwidth. In many applications, the feedback loop around the amplifier has gain (e.g., logarithmic amplifiers); overcompensation can stabilize these circuits with a single capacitor.

The availability of the compensation terminals permits the use of feedforward frequency compensation to enhance slew rate in low closed-loop gain configurations. The inverter slew rate is increased to $1.4\text{V}/\mu\text{s}$. The voltage follower feedforward scheme bypasses the amplifier's gain stages and slews at nearly $10\text{V}/\mu\text{s}$.

The inputs of the LT1008 are protected with back-to-back diodes. Current limiting resistors are not used, because the leakage of these resistors would prevent the realization of picoampere level bias currents at elevated temperatures.

In the voltage follower configuration, when the input is driven by a fast, large-signal pulse ($>1\text{V}$), the input protection diodes effectively short the output to the input during slewing, and a current, limited only by the output short-circuit protection, will flow through the diodes.

The use of a feedback resistor, as shown in the voltage follower feedforward diagram, is recommended because this resistor keeps the current below the short-circuit limit, resulting in faster recovery and settling of the output.

Inverter Feedforward Compensation

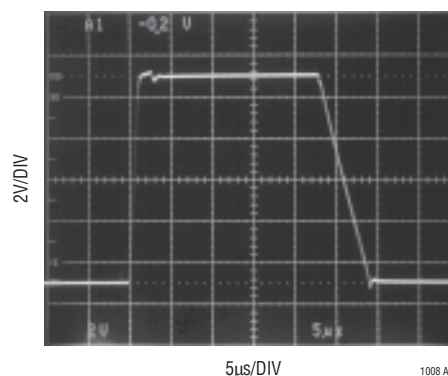
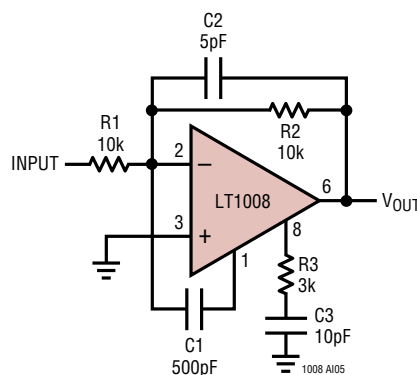

APPLICATIONS INFORMATION

Follower Feedforward Compensation

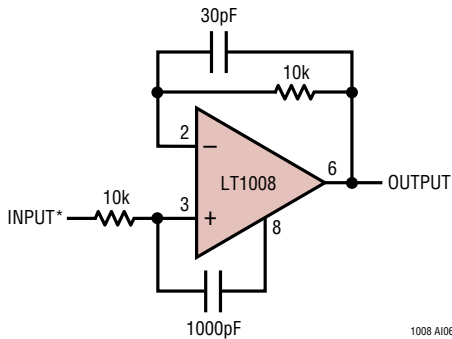

*SOURCE RESISTANCE $\leq 15k$ FOR STABILITY

1008 A106

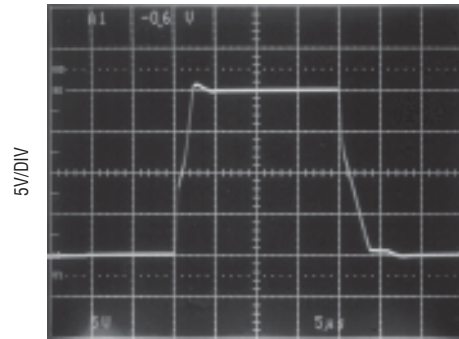

5µs/DIV

1008 A107

TYPICAL APPLICATIONS

Logarithmic Amplifier

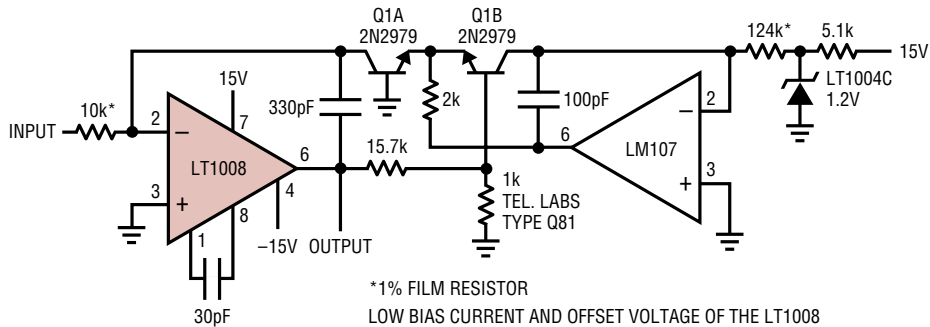

*1% FILM RESISTOR

LOW BIAS CURRENT AND OFFSET VOLTAGE OF THE LT1008 ALLOW 4.5 DECADES OF VOLTAGE INPUT LOGGING

Amplifier for Bridge Transducers

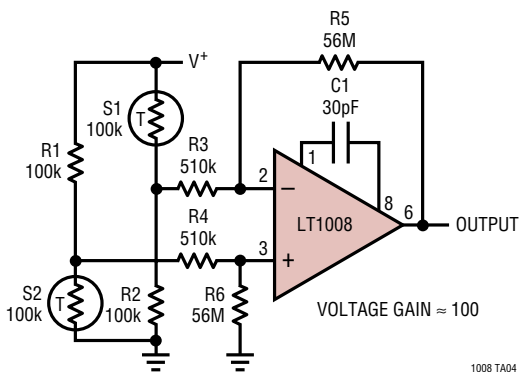

1008 TA04

Saturated Standard Cell Amplifier

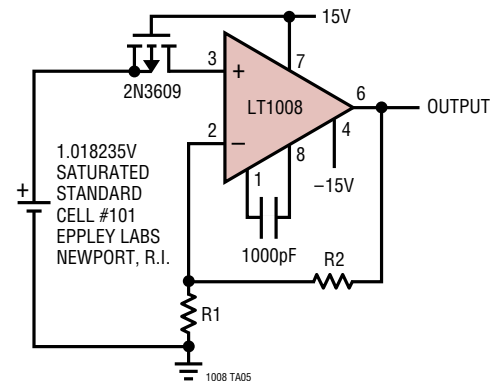

1008 TA05

THE TYPICAL 30pA BIAS CURRENT OF THE LT1008 WILL DEGRADE THE STANDARD CELL BY ONLY 1ppm/YEAR. NOISE IS A FRACTION OF A ppm. UNPROTECTED GATE MOSFET ISOLATES STANDARD CELL ON POWER DOWN

TYPICAL APPLICATIONS

Amplifier for Photodiode Sensor

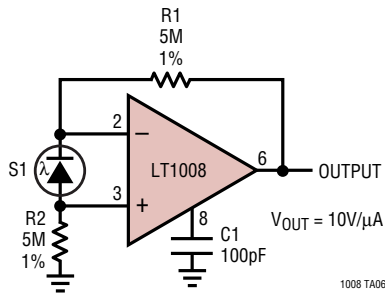

1008 TA06

Five Decade Kelvin-Varley Divider Buffered by the LT1008

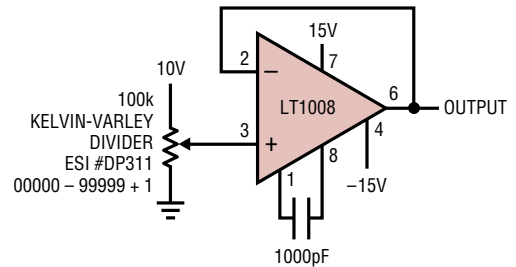

APPROXIMATE ERROR DUE TO NOISE, BIAS CURRENT, COMMON MODE REJECTION. VOLTAGE GAIN OF THE AMPLIFIER IS 1/5 OF A LEAST SIGNIFICANT BIT

1008 TA07

The LT1008 integrator extends low frequency range. Total dynamic range is 0.01Hz to 10kHz (or 120dB) with 0.01% linearity.

Extended Range Charge Pump Voltage to Frequency Converter

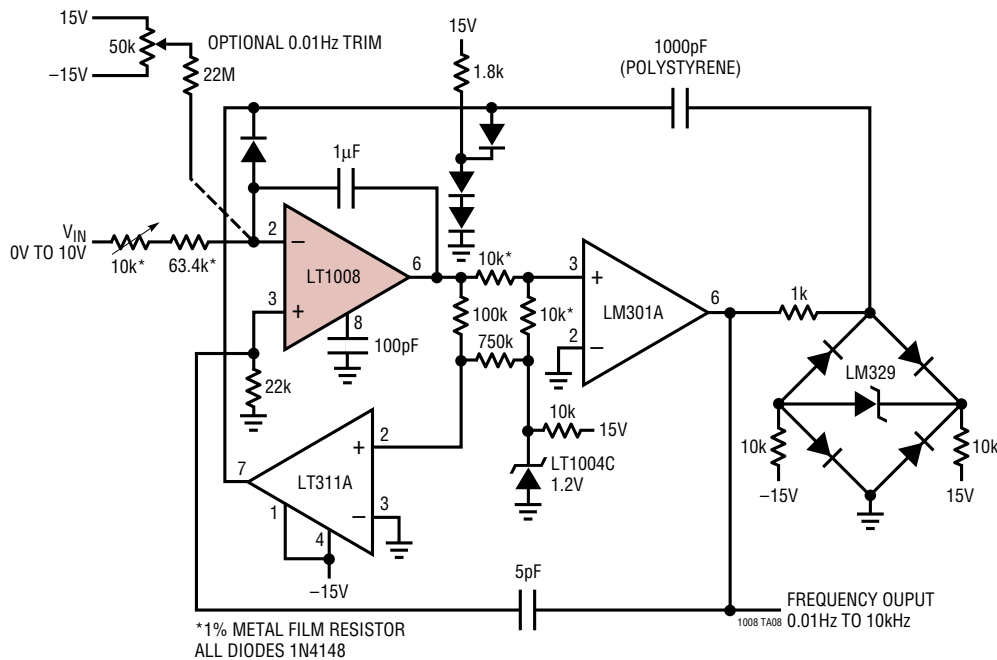

1008 TA08

TYPICAL APPLICATIONS

Precision, Fast Settling, Lowpass Filter

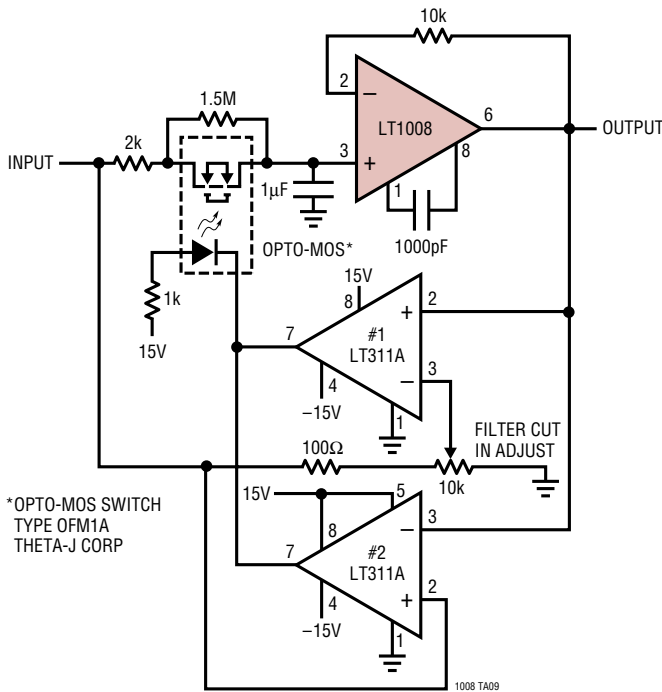

*OPTO-MOS SWITCH
TYPE OFM1A
THETA-J CORP

1008 TA09

This circuit is useful where fast signal acquisition and high precision are required, as in electronic scales.

The filter's time constant is set by the 2k resistor and the 1µF capacitor until comparator 1 switches. The time constant is then set by the 1.5M resistor and the 1µF capacitor. Comparator 2 provides a quick reset.

The circuit settles to a final value three times as fast as a simple 1.5M-1µF filter with almost no DC error.

Fast Precision Inverters

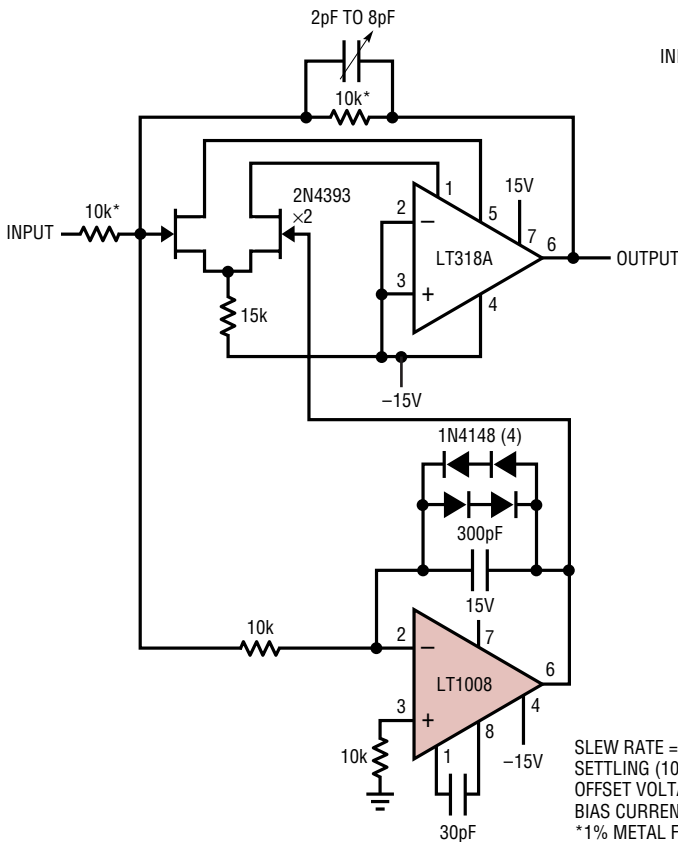

SLEW RATE = 100V/µs
SETTLING (10V STEP) = 5µs TO 0.01%
OFFSET VOLTAGE = 30µV
BIAS CURRENT DC = 30pA
*1% METAL FILM

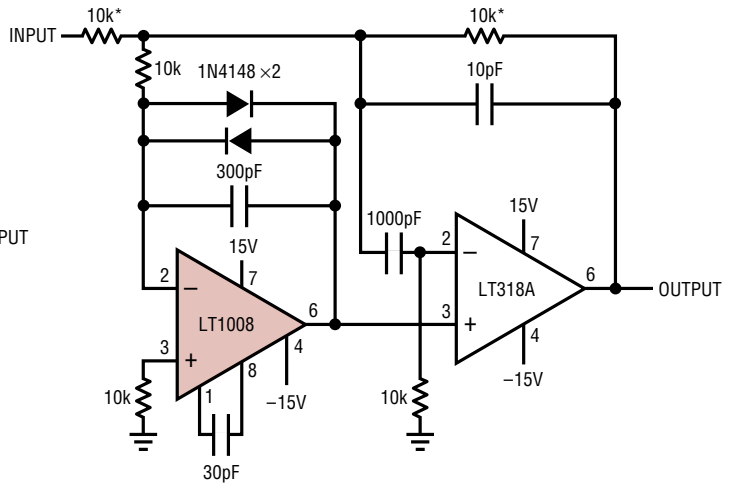

FULL POWER BANDWIDTH = 2MHz
SLEW RATE AT 50V/µs
SETTLING (10V STEP) = 12µs TO 0.01%
BIAS CURRENT DC = 30pA
OFFSET DRIFT = 0.3µV/°C
OFFSET VOLTAGE = 30µV
*1% METAL FILM

1008 TA10

1008fb

SCHEMATIC DIAGRAM

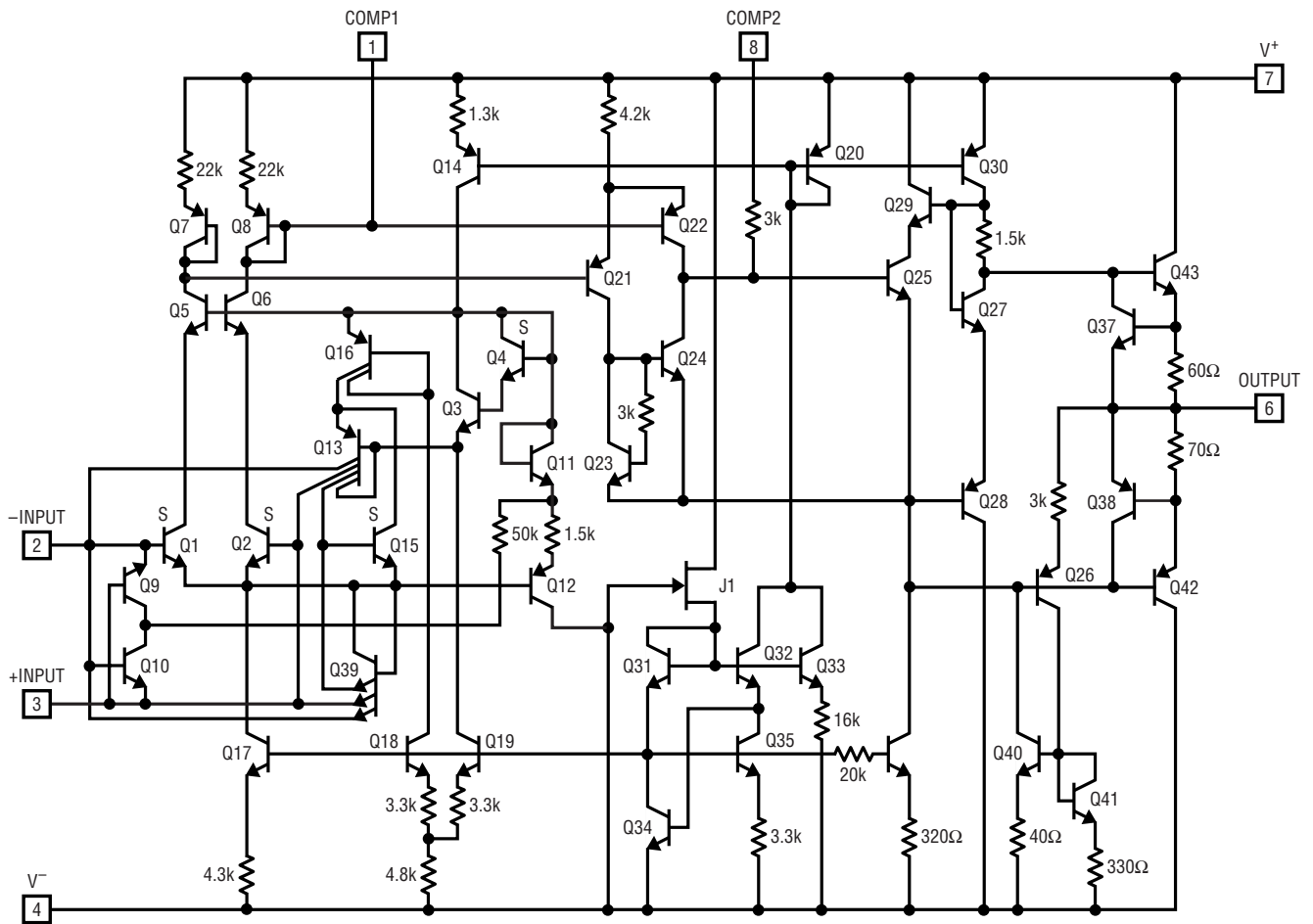

PACKAGE DESCRIPTION

N8 Package 8-Lead PDIP (Narrow .300 Inch) (Reference LTC DWG # 05-08-1510)

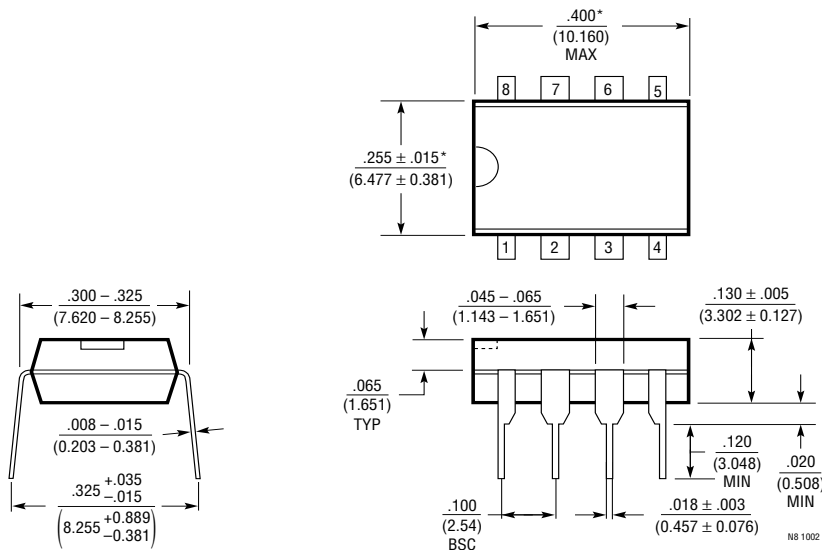

NOTE:
1. DIMENSIONS ARE $\frac{\text{INCHES}}{\text{MILLIMETERS}}$
*THESE DIMENSIONS DO NOT INCLUDE MOLD FLASH OR PROTRUSIONS.
MOLD FLASH OR PROTRUSIONS SHALL NOT EXCEED .010 INCH (0.254mm)

S8 Package 8-Lead Plastic Small Outline (Narrow .150 Inch) (Reference LTC DWG # 05-08-1610)

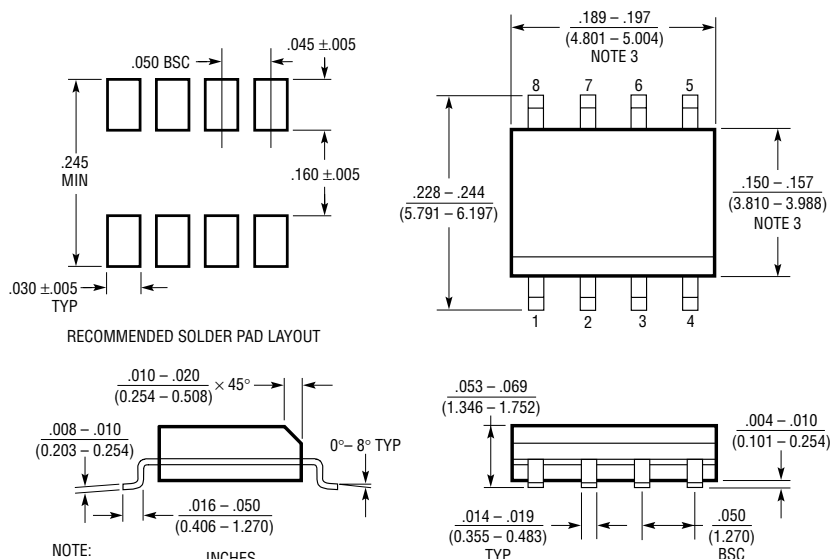

NOTE:
1. DIMENSIONS IN $\frac{\text{INCHES}}{\text{MILLIMETERS}}$
2. DRAWING NOT TO SCALE
3. THESE DIMENSIONS DO NOT INCLUDE MOLD FLASH OR PROTRUSIONS.
MOLD FLASH OR PROTRUSIONS SHALL NOT EXCEED .006" (0.15mm)

S08 0303

TYPICAL APPLICATION

Ammeter measures currents from 100pA to 100μA without the use of expensive high value resistors. Accuracy at

100μA is limited by the offset voltage between Q1 and Q2 and at 100pA by the inverting bias current of the LT1008.

Ammeter with Six Decade Range

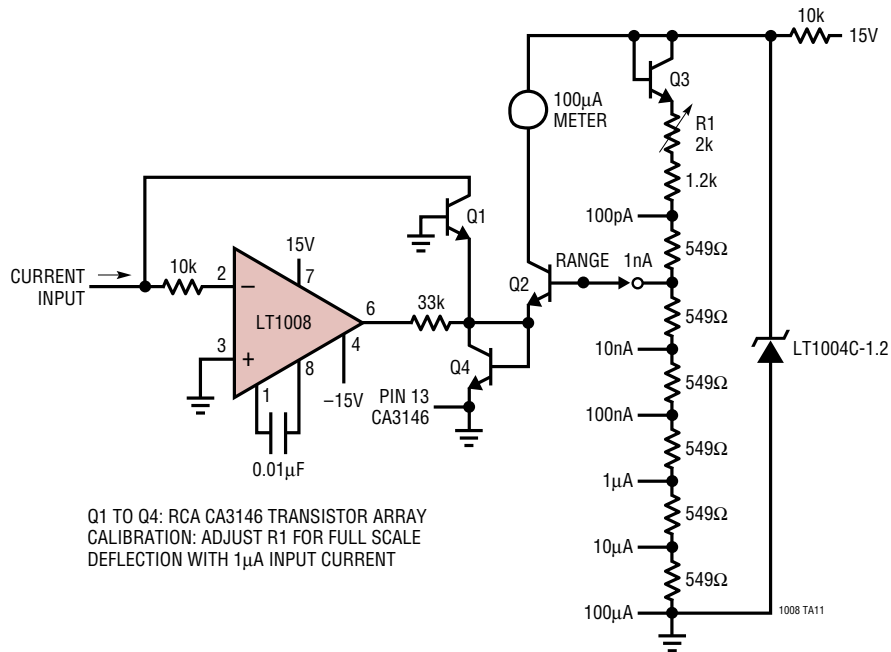

RELATED PARTS

| PART NUMBER | DESCRIPTION | COMMENTS |
|---------------|---|------------------------------------|
| LT1012 | Picoamp Input Current, Microvolt Offset, Low Noise Op Amp | Internally Compensated LT1008 |
| LT1112 | Dual Low Power, Precision, Picoamp Input Op Amp | Dual LT1012 |
| LT1880 | SOT-23, Rail-to-Rail Output, Picoamp Input Current Precision Op Amp | Single SOT-23 Version of LT1884 |
| LT1881/LT1882 | Dual and Quad Rail-to-Rail Output, Picoamp Input Precision Op Amps | Dual/Quad C _{LOAD} Stable |
| LT1884/LT1885 | Dual and Quad Rail-to-Rail Output, Picoamp Input Precision Op Amps | Dual/Quad Faster LT1881/LT1882 |

X-ON Electronics

Largest Supplier of Electrical and Electronic Components

Click to view similar products for [Precision Amplifiers](#) category:

Click to view products by [Analog Devices](#) manufacturer:

Other Similar products are found below :

[561681F](#) [LT6005HGN#PBF](#) [LT6238CGN#PBF](#) [LT6238HGN#PBF](#) [OP05CN8#PBF](#) [OP227GN#PBF](#) [LT6020IDD-1#PBF](#) [LT1124CS8#TR](#)
[NCV20166SN2T1G](#) [NCS21802MUTBG](#) [LT1637MPS8](#) [LT1498IS8](#) [LT1492CS8](#) [TLC27L7CP](#) [TLV2473CDR](#) [LMP2234AMA/NOPB](#)
[LMP7707MA/NOPB](#) [5962-8859301M2A](#) [LMP2231AMAE/NOPB](#) [LMP2234AMTE/NOPB](#) [LMC6022IM/NOPB](#) [LMC6024IM/NOPB](#)
[LMC6081IMX/NOPB](#) [LMP2011MA/NOPB](#) [LMP2231AMFE/NOPB](#) [LMP2232BMA/NOPB](#) [LMP2234AMAE/NOPB](#) [LMP7717MAE/NOPB](#)
[LMV2011MA/NOPB](#) [TLC2201AMDG4](#) [TLE2024BMDWG4](#) [TLV2474AQDRG4Q1](#) [TLV2472QDRQ1](#) [TLC4502IDR](#) [TLC27M2ACP](#)
[TLC2652Q-8DG4](#) [OPA2107APG4](#) [TL054AIDR](#) [TLC272CD](#) [AD8539ARMZ](#) [LTC6084HDD#PBF](#) [LT1638CMS8#TRPBF](#)
[LTC1050CN8#PBF](#) [LT1112ACN8#PBF](#) [LT1996AIDD#PBF](#) [LT1112CN8#PBF](#) [LTC6087CDD#PBF](#) [LT1078S8#PBF](#) [LT1079ACN#PBF](#)
[LTC6242HVCDHC#PBF](#)