

Micropower DC/DC Converter

Adjustable and Fixed 5V, 12V

FEATURES

- No Design Required
- Operates at Supply Voltages from 1V to 30V
- Consumes Only 95 μ A Supply Current
- Works in Step-Up or Step-Down Mode
- Only Three External Off-the-Shelf Components Required
- Low-Battery Detector Comparator On-Chip
- User-Adjustable Current Limit
- Internal 1A Power Switch
- Fixed or Adjustable Output Voltage Versions
- Space-Saving 8-Pin PDIP or SO-8 Package

APPLICATIONS

- Pagers
- Cameras
- Single-Cell to 5V Converters
- Battery Backup Supplies
- Laptop and Palmtop Computers
- Cellular Telephones
- Portable Instruments
- 4mA to 20mA Loop Powered Instruments
- Hand-Held Inventory Computers
- Battery-Powered α , β , and γ Particle Detectors

DESCRIPTION

The LT[®]1073 is a versatile micropower DC/DC converter. The device requires only three external components to deliver a fixed output of 5V or 12V. The very low minimum supply voltage of 1V allows the use of the LT1073 in applications where the primary power source is a single cell. An on-chip auxiliary gain block can function as a low-battery detector or linear post-regulator.

Average current drain of the LT1073-5 used as shown in the Typical Application circuit below is just 135 μ A unloaded, making it ideal for applications where long battery life is important. The circuit shown can deliver 5V at 40mA from an input as low as 1.25V and 5V at 10mA from a 1V input.

The device can easily be configured as a step-up or step-down converter, although for most step-down applications or input sources greater than 3V, the LT1173 is recommended. Switch current limiting is user-adjustable by adding a single external resistor. Unique reverse-battery protection circuitry limits reverse current to safe, non-destructive levels at reverse supply voltages up to 1.6V.

LT, LTC, and LT are registered trademarks of Linear Technology Corporation.

TYPICAL APPLICATION

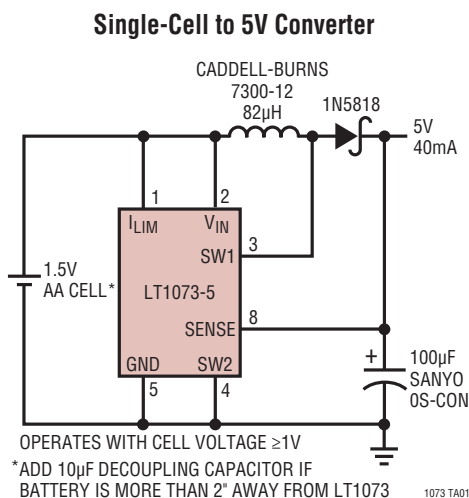

**Single Alkaline "AA" Cell Operating
Hours vs DC Load Current**

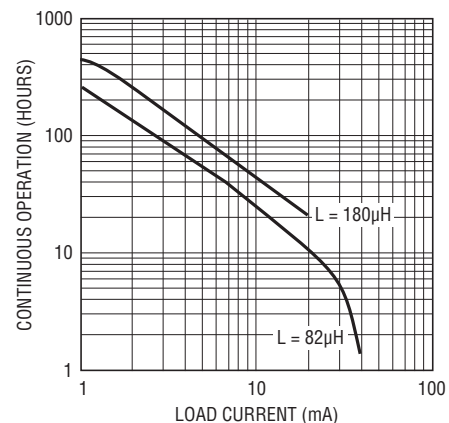

LT1073

ABSOLUTE MAXIMUM RATINGS

(Note 1)

Supply Voltage, Step-Up Mode	15V
Supply Voltage, Step-Down Mode	36V
SW1 Pin Voltage	50V
SW2 Pin Voltage	-0.4 to V_{IN}
Feedback Pin Voltage (LT1073)	5V
Switch Current	1.5A
Maximum Power Dissipation	500mW
Operating Temperature Range	0°C to 70°C
Storage Temperature Range	-65°C to 150°C
Lead Temperature (Soldering, 10 sec).....	300°C

PIN CONFIGURATION

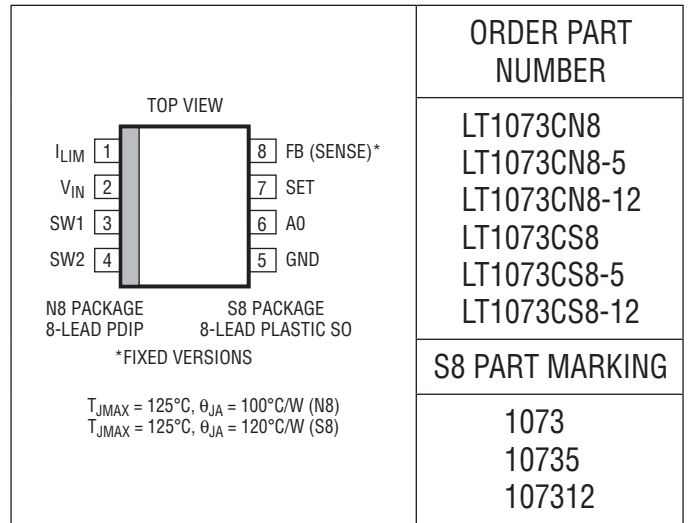

Consult factory for parts specified with wider operating temperature ranges.

ELECTRICAL CHARACTERISTICS

The ● denotes the specifications which apply over the full operating temperature range, otherwise specifications are at $T_A = 25^\circ\text{C}$. $V_{IN} = 1.5\text{V}$ unless otherwise specified.

SYMBOL	PARAMETER	CONDITIONS	MIN	TYP	MAX	UNITS	
I_Q	Quiescent Current	Switch Off	●	95	130	μA	
I_Q	Quiescent Current, Step-Up Mode Configuration	No Load		135		μA	
		LT1073-5		250		μA	
		LT1073-12					
V_{IN}	Input Voltage	Step-Up Mode	●	1.15	12.6	V	
				1.0	12.6	V	
		Step-Down Mode	●		30	V	
	Comparator Trip Point Voltage	LT1073 (Note 2)	●	202	212	222	mV
V_{OUT}	Output Sense Voltage	LT1073-5 (Note 3)	●	4.75	5	5.25	V
		LT1073-12 (Note 3)	●	11.4	12	12.6	V
	Comparator Hysteresis	LT1073	●		5	10	mV
	Output Hysteresis	LT1073-5	●		125	250	mV
		LT1073-12	●		300	600	mV
f_{OSC}	Oscillator Frequency		●	15	19	23	kHz
DC	Duty Cycle	Full Load ($V_{FB} = V_{REF}$)	●	65	72	80	%
t_{ON}	Switch ON Time		●	30	38	50	μs
I_{FB}	Feedback Pin Bias Current	LT1073, $V_{FB} = 0\text{V}$	●		10	50	nA
I_{SET}	Set Pin Bias Current	$V_{SET} = V_{REF}$	●		60	120	nA
V_{AO}	A0 Output Low	$I_{AO} = -100\mu\text{A}$	●		0.15	0.4	V
	Reference Line Regulation	$1\text{V} \leq V_{IN} \leq 1.5\text{V}$	●		0.35	1.0	%V
		$1.5\text{V} \leq V_{IN} \leq 12\text{V}$	●		0.05	0.1	%V
V_{CESAT}	Switch Saturation Voltage	$V_{IN} = 1.5\text{V}$, $I_{SW} = 400\text{mA}$	●		300	400	mV
	Set-Up Mode					600	mV
		$V_{IN} = 1.5\text{V}$, $I_{SW} = 500\text{mA}$	●		400	550	mV
						750	mV
		$V_{IN} = 5\text{V}$, $I_{SW} = 1\text{A}$	●		700	1000	mV
						1500	mV
A_V	A2 Error Amp Gain	$R_L = 100\text{k}\Omega$ (Note 4)	●	400	1000		V/V

ELECTRICAL CHARACTERISTICS The ● denotes the specifications which apply over the full operating temperature range, otherwise specifications are at $T_A = 25^\circ\text{C}$. $V_{IN} = 1.5\text{V}$ unless otherwise specified.

SYMBOL	PARAMETER	CONDITIONS	MIN	TYP	MAX	UNITS
I_{REV}	Reverse Battery Current	(Note 5)		750		mA
I_{LIM}	Current Limit	220 Ω Between I_{LIM} and V_{IN}		400		mA
	Current Limit Temperature Coefficient			-0.3		%/ $^\circ\text{C}$
I_{LEAK}	Switch OFF Leakage Current	Measured at SW1 Pin		1	10	μA
V_{SW2}	Maximum Excursion Below GND	$I_{SW1} \leq 10\mu\text{A}$, Switch Off		-400	-350	mV

Note 1: Absolute Maximum Ratings are those values beyond which the life of a device may be impaired.

Note 2: This specification guarantees that both the high and low trip point of the comparator fall within the 202mV to 222mV range.

Note 3: This specification guarantees that the output voltage of the fixed versions will always fall within the specified range. The waveform at the SENSE pin will exhibit a sawtooth shape due to the comparator hysteresis.

Note 4: 100k resistor connected between a 5V source and the AO pin.

Note 5: The LT1073 is guaranteed to withstand continuous application of 1.6V applied to the GND and SW2 pins while V_{IN} , I_{LIM} and SW1 pins are grounded.

TYPICAL PERFORMANCE CHARACTERISTICS

Saturation Voltage Step-Up Mode (SW2 Pin Grounded)

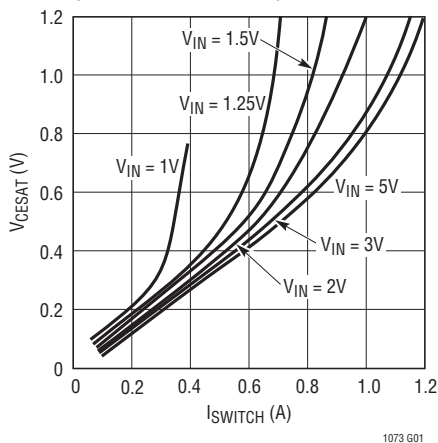

Switch ON Voltage Step-Down Mode (SW1 Pin Connected to V_{IN})

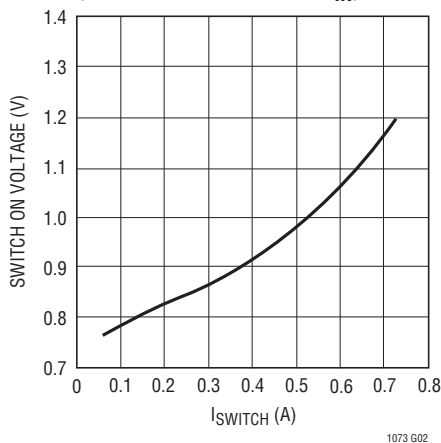

Maximum Switch Current vs R_{LIM}

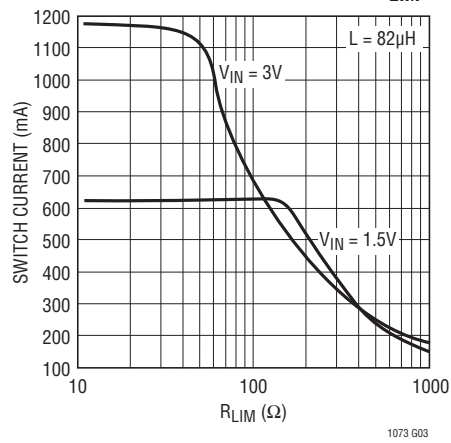

FB Pin Bias Current vs Temperature

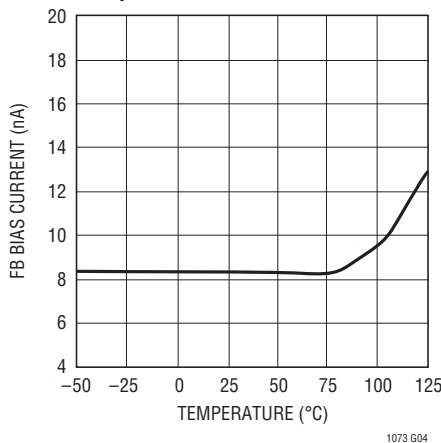

SET Pin Bias Current vs Temperature

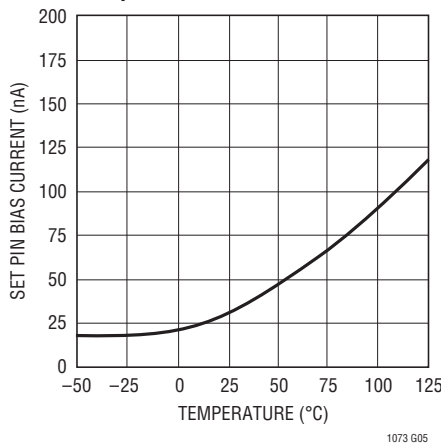

“Gain Block” Gain

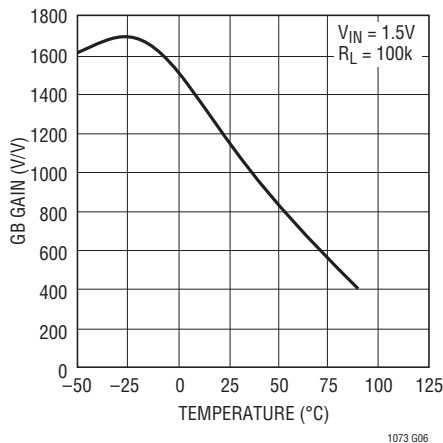

TYPICAL PERFORMANCE CHARACTERISTICS

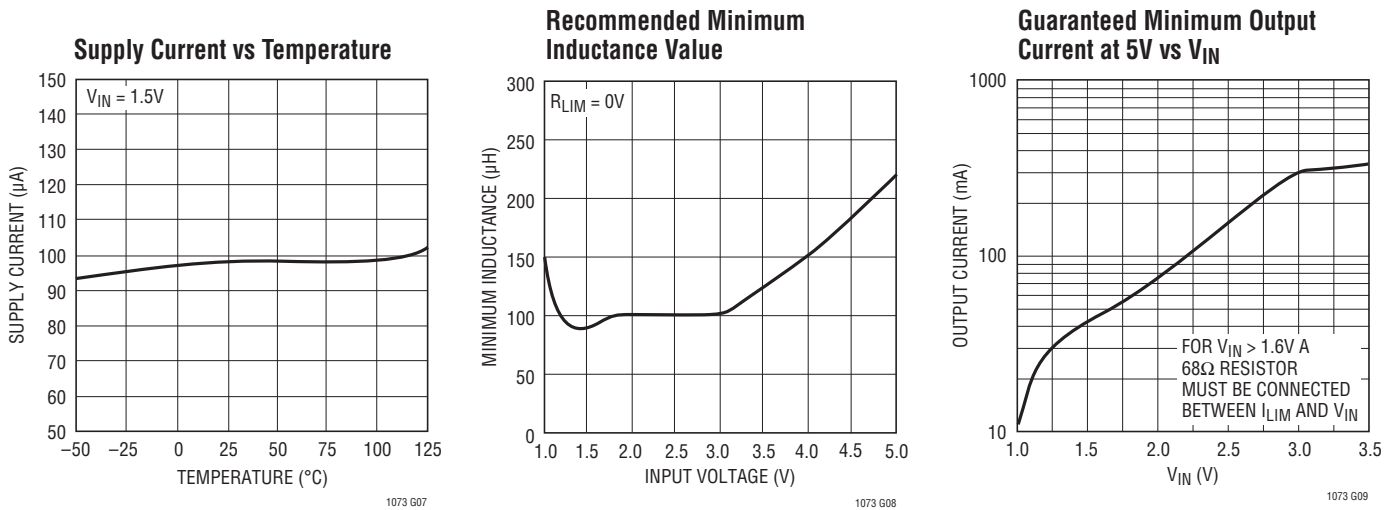

PIN FUNCTIONS

I_{LIM} (Pin 1): Connect this pin to V_{IN} for normal use. Where lower current limit is desired, connect a resistor between I_{LIM} and V_{IN} . A 220 Ω resistor will limit the switch current to approximately 400mA.

V_{IN} (Pin 2): Input Supply Voltage

SW1 (Pin 3): Collector of Power Transistor. For step-up mode connect to inductor/diode. For step-down mode connect to V_{IN} .

SW2 (Pin 4): Emitter of Power Transistor. For step-up mode connect to ground. For step-down mode connect to inductor/diode. This pin must never be allowed to go more than a Schottky diode drop below ground.

GND (Pin 5): Ground.

AO (Pin 6): Auxiliary Gain Block (GB) Output. Open collector, can sink 100 μA .

SET (Pin 7): GB Input. GB is an op amp with positive input connected to SET pin and negative input connected to 212mV reference.

FB/SENSE (Pin 8): On the LT1073 (adjustable) this pin goes to the comparator input. On the LT1073-5 and LT1073-12, this pin goes to the internal application resistor that sets output voltage.

BLOCK DIAGRAMS

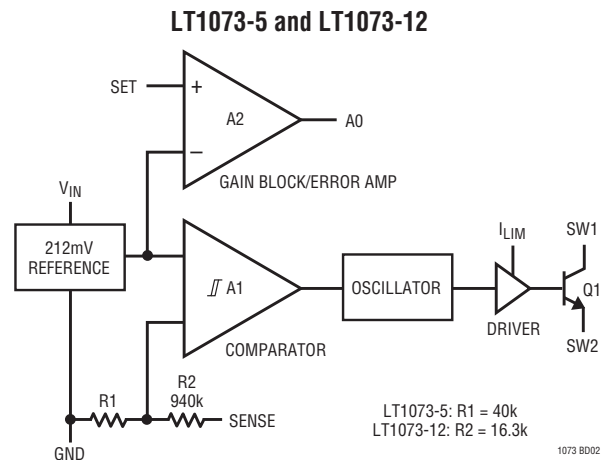
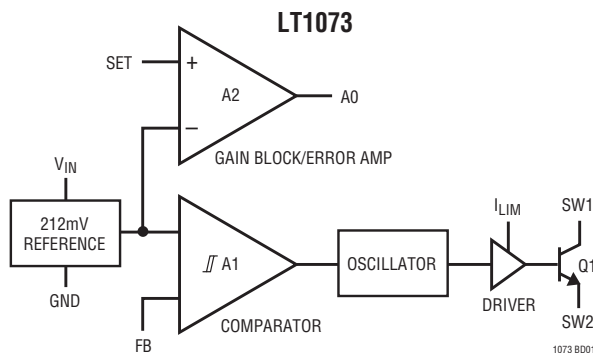

OPERATION

LT1073

The LT1073 is gated oscillator switcher. This type architecture has very low supply current because the switch is cycled only when the feedback pin voltage drops below the reference voltage. Circuit operation can best be understood by referring to the LT1073 Block Diagram. Comparator A1 compares the FB pin voltage with the 212mV reference signal. When FB drops below 212mV, A1 switches on the 19kHz oscillator. The driver amplifier boosts the signal level to drive the output NPN power switch Q1. An adaptive base drive circuit senses switch current and provides just enough base drive to ensure switch saturation without overdriving the switch, resulting in higher efficiency. The switch cycling action raises the output voltage and FB pin voltage. When the FB voltage is sufficient to trip A1, the oscillator is gated off. A small amount of hysteresis built into A1 ensures loop stability without external frequency compensation. When the comparator is low the oscillator and all high current circuitry is turned off, lowering device quiescent current to just 95 μ A for the reference, A1 and A2.

The oscillator is set internally for 38 μ s ON time and 15 μ s OFF time, optimizing the device for step-up circuits where $V_{OUT} \approx 3V_{IN}$, e.g., 1.5V to 5V. Other step-up ratios as well as step-down (buck) converters are possible at slight losses in maximum achievable power output.

A2 is a versatile gain block that can serve as a low-battery detector, a linear post-regulator, or drive an undervoltage lockout circuit. The negative input of A2 is internally connected to the 212mV reference. An external resistor divider from V_{IN} to GND provides the trip point for A2. The AO output can sink 100 μ A (use a 56k resistor pull-up to 5V). This line can signal a microcontroller that the battery voltage has dropped below the preset level.

A resistor connected between the I_{LIM} pin and V_{IN} adjusts maximum switch current. When the switch current exceeds the set value, the switch is turned off. This feature is especially useful when small inductance values are used with high input voltages. If the internal current limit of 1.5A is desired, I_{LIM} should be tied directly to V_{IN} . Propagation delay through the current-limit circuitry is about 2 μ s.

In step-up mode, SW2 is connected to ground and SW1 drives the inductor. In step-down mode, SW1 is connected to V_{IN} and SW2 drives the inductor. Output voltage is set by the following equation in either step-up or step-down modes where R1 is connected from FB to GND and R2 is connected from V_{OUT} to FB.

$$V_{OUT} = (212\text{mV}) \left(\frac{R2}{R1} + 1 \right)$$

LT1073-5 and LT1073-12

The LT1073-5 and LT1073-12 fixed output voltage versions have the gain-setting resistor on-chip. Only three external components are required to construct a fixed-output converter. 5 μ A flows through R1 and R2 in the LT1073-5, and 12.3 μ A flows in the LT1073-12. This current represents a load and the converter must cycle from time to time to maintain the proper output voltage. Output ripple, inherently present in gated-oscillator designs, will typically run around 150mV for the LT1073-5 and 350mV for the LT1073-12 with the proper inductor/capacitor selection. This output ripple can be reduced considerably by using the gain block amp as a preamplifier in front of the FB pin. See the Applications Information section for details.

APPLICATIONS INFORMATION

Table 1. Component Selection for Step-Up Converters

INPUT VOLTAGE (V)	BATTERY TYPE	OUTPUT VOLTAGE (V)	OUTPUT CURRENT (MIN)	INDUCTOR VALUE (μH)	INDUCTOR PART NUMBER	CAPACITOR VALUE (μF)	NOTES
1.55-1.25	Single Alkaline	3	60mA	82	G GA10-822K, CB 7300-12	150	
1.30-1.05	Single Ni-Cad	3	20mA	180	G GA10-183K, CB 7300-16	47	
1.55-1.25	Single Alkaline	5	30mA	82	G GA10-822K, CB 7300-12	100	
1.30-1.05	Single Ni-Cad	5	10mA	180	G GA10-183K, CB 7300-16	22	
3.1-2.1	Two Alkaline	5	80mA	120	G GA10-123K, CB 7300-14	470	*
3.1-2.1	Two Alkaline	5	25mA	470	G GA10-473K, CB 7300-21	150	*
3.3-2.5	Lithium	5	100mA	150	G GA40-153K, CB 6860-15	470	*
3.1-2.1	Two Alkaline	12	25mA	120	G GA10-123K, CB 7300-14	220	
3.1-2.1	Two Alkaline	12	5mA	470	G GA10-473K, CB 7300-21	100	
3.3-2.5	Lithium	12	30mA	150	G GA10-153K, CB 7300-15	220	
4.5-5.5	TTL Supply	12	90mA	220	G GA40-223K, CB 6860-17	470	*
4.5-5.5	TTL Supply	12	22mA	1000	G GA10-104K, CB 7300-25	100	*
4.5-5.5	TTL Supply	24	35mA	220	G GA40-223K, CB 6860-17	150	*

G = GOWANDA

CB = CADELLE-BURNS

*Add 68Ω from I_{LIM} to V_{IN}

Measuring Input Current at Zero or Light Load

Obtaining meaningful numbers for quiescent current and efficiency at low output current involves understanding how the LT1073 operates. At very low or zero load current, the device is idling for seconds at a time. When the output voltage falls enough to trip the comparator, the power switch comes on for a few cycles until the output voltage rises sufficiently to overcome the comparator hysteresis. When the power switch is on, inductor current builds up to hundreds of milliamperes. Ordinary digital multimeters are not capable of measuring average current because of bandwidth and dynamic range limitations. A different approach is required to measure the 100μA off-state and 500mA on-state currents of the circuit.

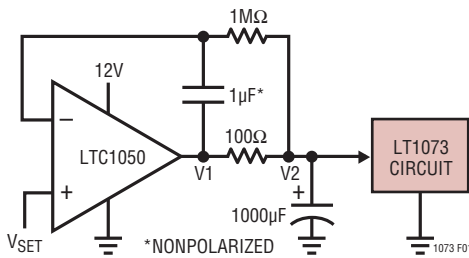

Figure 1. Test Circuit Measures No-Load Quiescent Current of LT1073 Converter

Quiescent current can be accurately measured using the circuit in Figure 1. V_{SET} is set to the input voltage of the

LT1073. The circuit must be “booted” by shorting V₂ to V_{SET}. After the LT1073 output voltage has settled, disconnect the short. Input voltage is V₂ and average input current can be calculated by this formula:

$$I_{IN} = \frac{V_2 - V_1}{100\Omega}$$

Inductor Selection

A DC/DC converter operates by storing energy as magnetic flux, in an inductor core and then switching this energy into the load. Since it is flux, not charge, that is stored, the output voltage can be higher, lower, or opposite in polarity to the input voltage by choosing an appropriate switching topology. To operate as an efficient energy transfer element, the inductor must fulfill three requirements. First, the inductance must be low enough for the inductor to store adequate energy under the worst-case condition of minimum input voltage and switch ON time. The inductance must also be high enough so that maximum current ratings of the LT1073 and inductor are not exceeded at the other worst-case condition of maximum input voltage and ON time. Additionally, the inductor core must be able to store the required flux, i.e., it must not saturate. At power levels generally encountered with LT1073-based designs, small axial-lead units with

APPLICATIONS INFORMATION

saturation current ratings in the 300mA to 1A range (depending on application) are adequate. Lastly, the inductor must have sufficiently low DC resistance so that excessive power is not lost as heat in the windings. An additional consideration is electro-magnetic interference (EMI). Toroid and pot core type inductors are recommended in applications where EMI must be kept to a minimum; for example, where there are sensitive analog circuitry or transducers nearby. Rod core types are a less expensive choice where EMI is not a problem.

Specifying a proper inductor for an application requires first establishing minimum and maximum input voltage, output voltage and output current. In a step-up converter, the inductive events add to the input voltage to produce the output voltage. Power required from the inductor is determined by:

$$P_L = (V_{OUT} + V_D - V_{IN})(I_{OUT})$$

where V_D is the diode drop (0.5V for a 1N5818 Schottky).

Maximum power in the inductor is

$$P_L = E_L \cdot f_{OSC}$$

$$= \frac{1}{2} L i_{PEAK}^2 \cdot f_{OSC}$$

where

$$i_{PEAK} = \left(\frac{V_{IN}}{R} \right) \left(1 - e^{-\frac{Rt_{ON}}{L}} \right)$$

R = Switch equivalent resistance (1Ω maximum) added to the DC resistance of the inductor and t_{ON} = ON time of the switch.

At maximum V_{IN} and ON time, i_{PEAK} should not be allowed to exceed the maximum switch current shown in Figure 2. Some input/output voltage combinations will cause continuous¹ mode operation. In these cases a resistor is needed between I_{LIM} (Pin 1) and V_{IN} (Pin 2) to keep switch current under control. See the “Using the I_{LIM} Pin” section for details.

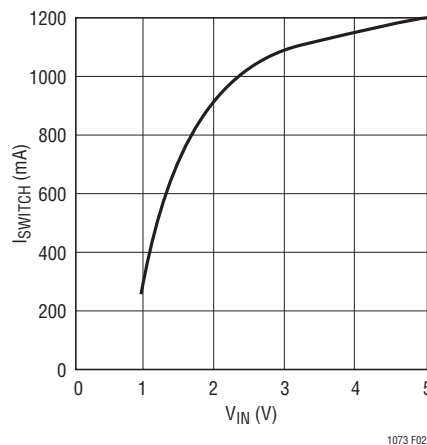

Figure 2. Maximum Switch Current vs Input Voltage

Capacitor Selection

Selecting the right output capacitor is almost as important as selecting the right inductor. A poor choice for a filter capacitor can result in poor efficiency and/or high output ripple. Ordinary aluminum electrolytics, while inexpensive and readily available, may have unacceptably poor equivalent series resistance (ESR) and ESL (inductance). There are low-ESR aluminum capacitors on the market specifically designed for switch-mode DC/DC converters which work much better than general purpose units. Tantalum capacitors provide still better performance at more expense. We recommend OS-CON capacitors from Sanyo Corporation (San Diego, CA). These units are physically quite small and have extremely low ESR. To illustrate, Figures 3, 4, and 5 show the output voltage of an LT1073 based converter with three 100μF capacitors. The peak switch current is 500mA in all cases. Figure 3 shows a Sprague 501D aluminum capacitor. V_{OUT} jumps by over 150mV when the switch turns off, followed by a drop in voltage as the inductor dumps into the capacitor. This works out to be an ESR of over 300mΩ. Figure 4 shows the same circuit, but with a Sprague 150D tantalum capacitor replacing the aluminum unit. Output jump is now about 30mV, corresponding to an ESR of 60mΩ. Figure 5 shows the circuit with an OS-CON unit. ESR is now only 30mΩ.

In very low power applications where every microampere is important, leakage current of the capacitor must be considered. The OS-CON units do have leakage current in the 5μA to 10μA range. If the load is also in the

NOTE 1: i.e., inductor current does not go to zero when the switch is off.

APPLICATIONS INFORMATION

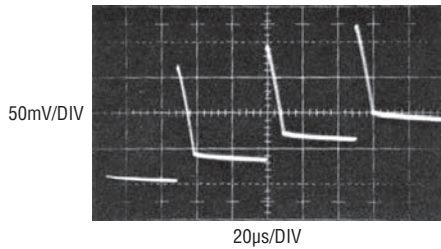

Figure 3. Aluminum

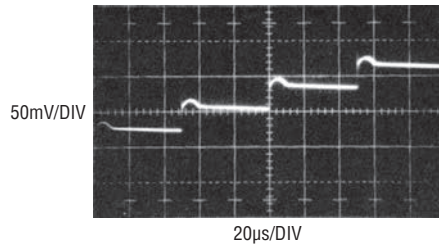

Figure 4. Tantalum

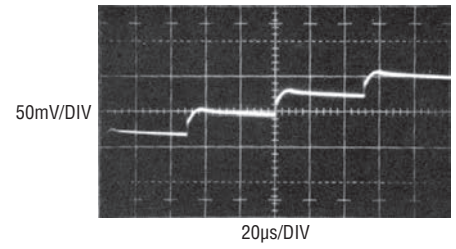

Figure 5. OS-CON

microampere range, a leaky capacitor will noticeably decrease efficiency. In this type application tantalum capacitors are the best choice, with typical leakage currents in the 1µA to 5µA range.

Diode Selection

Speed, forward drop and leakage current are the three main considerations in selecting a catch diode for LT1073 converters. “General-purpose” rectifiers such as the 1N4001 are *unsuitable* for use in *any* switching regulator application. Although they are rated at 1A, the switching time of a 1N4001 is in the 10µs to 50µs range. At best, efficiency will be severely compromised when these diodes are used and at worst, the circuit may not work at all. Most LT1073 circuits will be well served by a 1N5818 Schottky diode. The combination of 500mV forward drop at 1A current, fast turn-on and turn-off time and 4µA to 10µA leakage current fit nicely with LT1073 requirements. At peak switch currents of 100mA or less, a 1N4148 signal diode may be used. This diode has leakage current in the 1nA to 5nA range at 25°C and lower cost than a 1N5818. (You can also use them to get your circuit up and running, but beware of destroying the diode at 1A switch currents.) In situations where the load is intermittent and the LT1073 is idling most of the time, battery life can sometimes be extended by using a silicon diode such as the 1N4933, which can handle 1A but has leakage current of less than 1µA. Efficiency will decrease somewhat compared to a 1N5818 while delivering power, but the lower idle current may be more important.

Step-Up (Boost Mode) Operation

A step-up DC/DC converter delivers an output voltage higher than the input voltage. Step-up converters are

not short-circuit protected since there is a DC path from input to output.

The usual step-up configuration for the LT1073 is shown in Figure 6. The LT1073 first pulls SW1 low causing $V_{IN} - V_{CESAT}$ to appear across L1. A current then builds up in L1. At the end of the switch ON time the current in L1 is²:

$$i_{PEAK} = \frac{V_{IN}}{L} t_{ON}$$

NOTE 2: This simple expression neglects the effect of switch and coil resistance. These are taken into account in the “Inductor Selection” section.

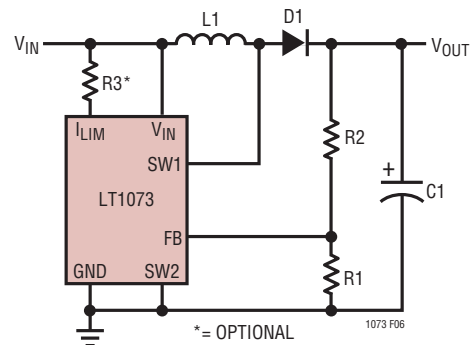

Figure 6. Step-Up Mode Hookup.
(Refer to Table 1 for Component Values)

Immediately after switch turn-off, the SW1 voltage pin starts to rise because current cannot instantaneously stop flowing in L1. When the voltage reaches $V_{OUT} + V_D$, the inductor current flows through D1 into C1, increasing V_{OUT} . This action is repeated as needed by the LT1073 to keep V_{FB} at the internal reference voltage of 212mV. R1 and R2 set the output voltage according to the formula:

$$V_{OUT} = \left(1 + \frac{R2}{R1}\right) (212mV)$$

APPLICATIONS INFORMATION

Step-Down (Buck Mode) Operation

A step-down DC/DC converter converts a higher voltage to a lower voltage. It is short-circuit protected because the switch is in series with the output. Step-down converters are characterized by low output voltage ripple but high input current ripple. The usual hookup for an LT1073-based step-down converter is shown in Figure 7.

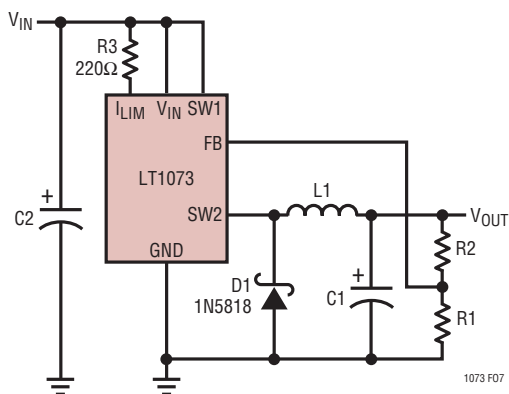

Figure 7. Step-Down Mode Hookup

When the switch turns on, SW2 pulls up to $V_{IN} - V_{SW}$. This puts a voltage across L1 equal to $V_{IN} - V_{SW} - V_{OUT}$, causing a current to build up in L1. At the end of the switch ON time, the current in L1 is equal to

$$i_{PEAK} = \frac{V_{IN} - V_{SW} - V_{OUT}}{L} t_{ON}$$

When the switch turns off the SW2 pin falls rapidly and actually goes below ground. D1 turns on when SW2 reaches 0.4V below ground. **D1 MUST BE A SCHOTTKY DIODE.** The voltage at SW2 must never be allowed to go below -0.5V. A silicon diode such as the 1N4933 will allow SW2 to go to -0.8V, causing potentially destructive power dissipation inside the LT1073. Output voltage is determined by

$$V_{OUT} = \left(1 + \frac{R2}{R1}\right) (212mV)$$

R3 programs switch current limit. This is especially important in applications where the input varies over a wide range. Without R3, the switch stays on for a fixed time each cycle. Under certain conditions the current in L1 can build up to excessive levels, exceeding the switch rating and/or

saturating the inductor. The 220Ω resistor programs the switch to turn off when the current reaches approximately 400mA. When using the LT1073 in step-down mode, output voltage should be limited to 6.2V or less.

Inverting Configurations

The LT1073 can be configured as a positive-to-negative converter (Figure 8), or a negative-to-positive converter (Figure 9). In Figure 8, the arrangement is very similar to a step-down, except that the high side of the feedback is referred to ground. This level shifts the output negative. As in the step-down mode, D1 must be a Schottky diode, and $|V_{OUT}|$ should be less than 6.2V.

In Figure 9, the input is negative while the output is positive. In this configuration, the magnitude of the input voltage can be higher or lower than the output voltage. A level shift, provided by the PNP transistor, supplies proper polarity feedback information to the regulator.

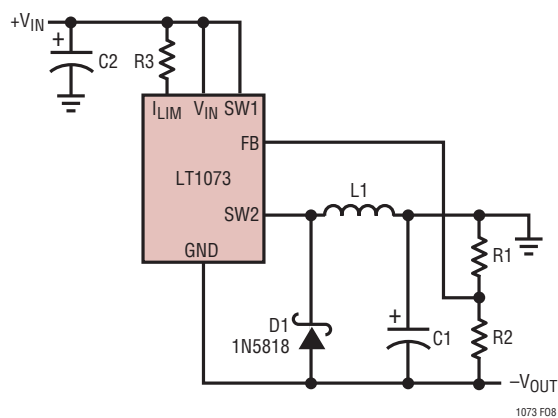

Figure 8. Positive-to-Negative Converter

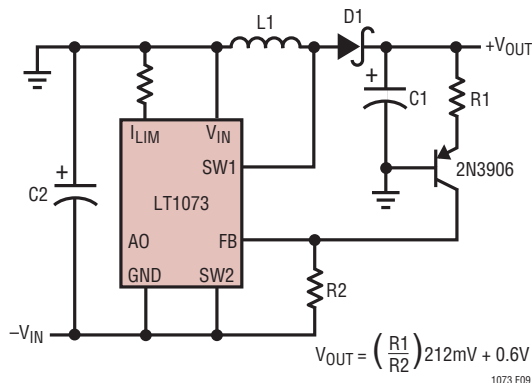

Figure 9. Negative-to-Positive Converter

APPLICATIONS INFORMATION

Using the I_{LIM} Pin

The LT1073 switch can be programmed to turn off at a set switch current, a feature not found on competing devices. This enables the input to vary over a wide range without exceeding the maximum switch rating or saturating the inductor. Consider the case where analysis shows the LT1073 must operate at an 800mA peak switch current with a 2V input. If V_{IN} rises to 4V, the peak switch current will rise to 1.6A, exceeding the maximum switch current rating. With the proper resistor (see the “Maximum Switch Current vs R_{LIM}” characteristic) selected, the switch current will be limited to 800mA, even if the input voltage increases. The LT1073 does this by sampling a small fraction of the switch current and passing this current through the external resistor. When the voltage on the I_{LIM} pin drops a V_{BE} below V_{IN}, the oscillator terminates the cycle. Propagation delay through this loop is about 2μs.

Another situation where the I_{LIM} feature is useful is when the device goes into continuous mode operation. This occurs in step-up mode when

$$\frac{V_{OUT} + V_{DIODE}}{V_{IN} - V_{SW}} < \frac{1}{1-DC}$$

When the input and output voltages satisfy this relationship, inductor current does not go to zero during the switch OFF time. When the switch turns on again, the current ramp starts from the nonzero current level in the inductor just prior to switch turn-on. As shown in

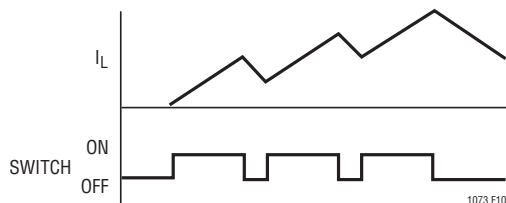

Figure 10. No Current Limit Causes Large Inductor Current Build-Up

Figure 10, the inductor current increases to a high level before the comparator turns off the oscillator. This high current can cause excessive output ripple and requires oversizing the output capacitor and inductor. With the I_{LIM} feature, however, the switch current turns off at a programmed level as shown in Figure 11, keeping output ripple to a minimum.

Using the Gain Block

The gain block (GB) on the LT1073 can be used as an error amplifier, low-battery detector or linear post-regulator. The gain block itself is a very simple PNP input op amp with an open-collector NPN output. The (-) input of the gain block is tied internally to the 212mV reference. The (+) input comes out on the SET pin.

Arrangement of the gain block as a low battery detector is straightforward. Figure 12 shows hookup. R1 and R2 need only be low enough in value so that the bias current of the SET input does not cause large errors. 100kΩ for R2 is adequate.

Output ripple of the LT1073, normally 150mV at 5V_{OUT}, can be reduced significantly by placing the gain block in front of the FB input as shown in Figure 13. This effectively reduces the comparator hysteresis by the gain of the gain block. Output ripple can be reduced to just a few millivolts using this technique. Ripple reduction works with step-down or inverting modes as well.

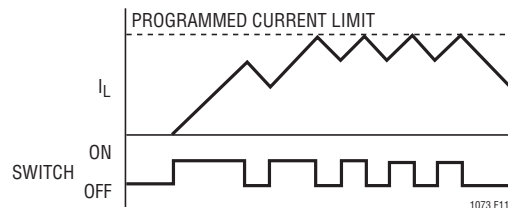

Figure 11. Current Limit Keeps Inductor Current Under Control

APPLICATIONS INFORMATION

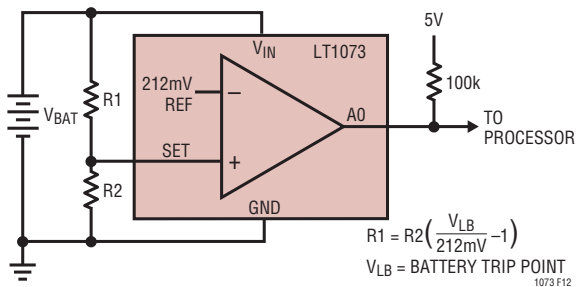

Figure 12. Settling Low Battery Detector Trip Point

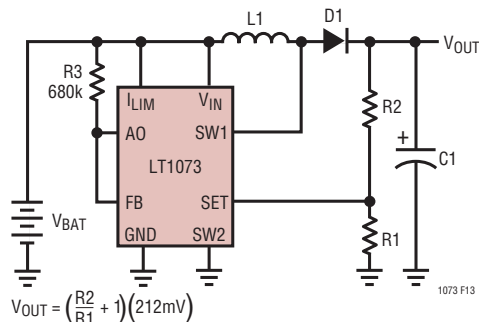

Figure 13. Output Ripple Reduction Using Gain Block

Table 2. Inductor Manufacturers

MANUFACTURER	PART NUMBERS
Gowanda Electronics Corporation 1 Industrial Place Gowanda, NY 14070 716-532-2234	GA10 Series GA40 Series
Caddell-Burns 258 East Second Street Mineola, NY 11501 516-746-2310	7300 Series 6860 Series
Coiltronics International 984 S.W. 13th Court Pompano Beach, FL 33069 305-781-8900	Custom Toroids Surface Mount
Toko America Incorporated 1250 Feehanville Drive Mount Prospect, IL 60056 312-297-0070	Type 8RBS
Renco Electronics Incorporated 60 Jefryn Boulevard, East Deer Park, NY 11729 800-645-5828	RL1283 RL1284

Table 3. Capacitor Manufacturers

MANUFACTURER	PART NUMBERS
Sanyo Video Components 1201 Sanyo Avenue San Diego, CA 92073 619-661-6322	OS-CON Series
Nichicon America Corporation 927 East State Parkway Schaumburg, IL 60173 708-843-7500	PL Series
Sprague Electric Company Lower Main Street Stanford, ME 04073 207-324-4140	150D Solid Tantalums 550D Tantalex

TYPICAL APPLICATIONS

1.5V to 3V Step-Up Converter

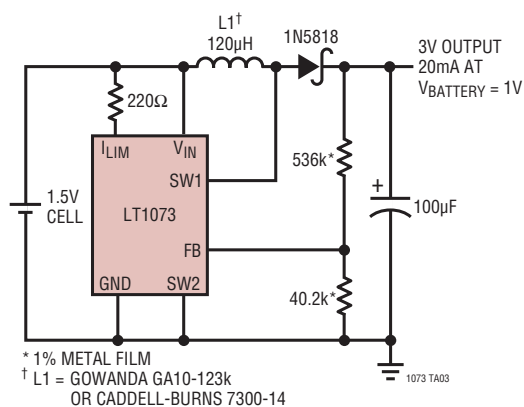

* 1% METAL FILM
† L1 = GOWANDA GA10-123k
OR CADDELL-BURNS 7300-14

1.5V to 9V Step-Up Converter

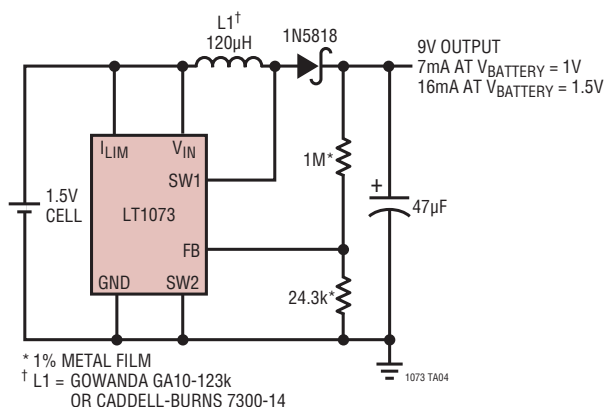

* 1% METAL FILM
† L1 = GOWANDA GA10-123k
OR CADDELL-BURNS 7300-14

TYPICAL APPLICATIONS

1.5V to 12V Step-Up Converter

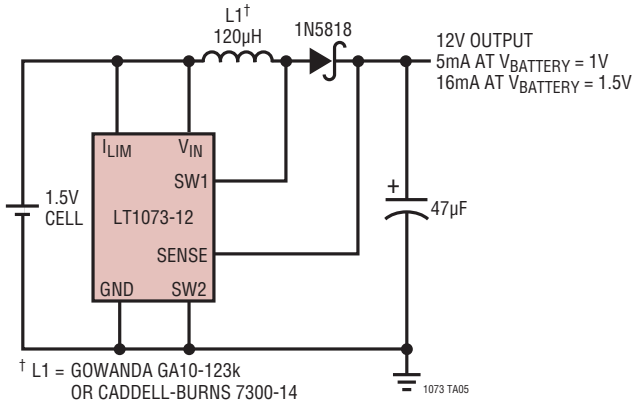

3V to 5V Step-Up Converter

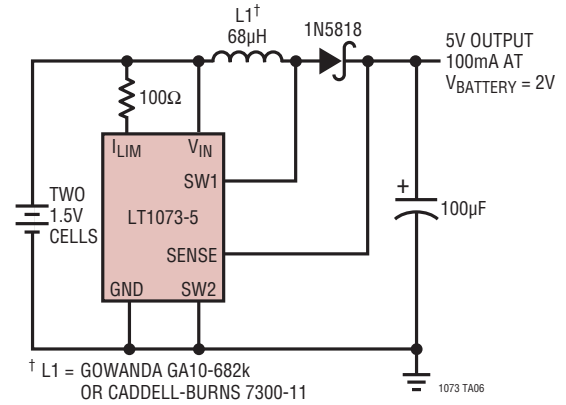

3V to 12V Step-Up Converter

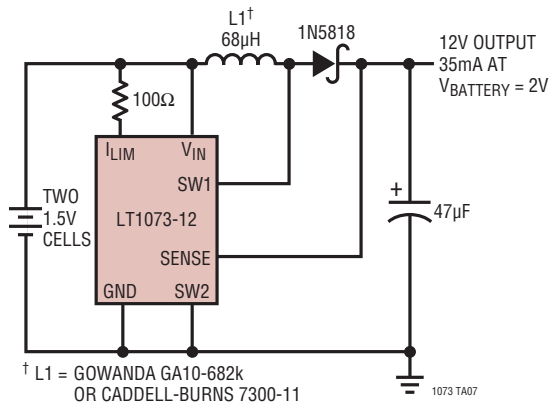

3V to 15V Step-Up Converter

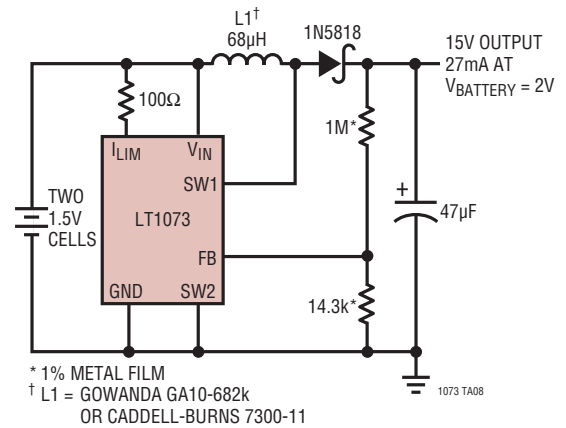

5V to 12V Step-Up Converter

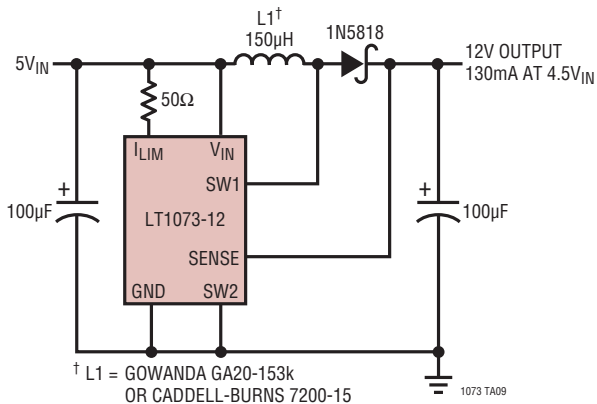

5V to 15V Step-Up Converter

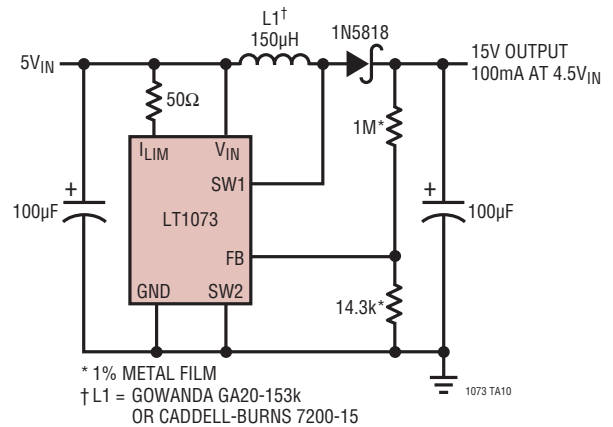

TYPICAL APPLICATIONS

1.5V to 5V Step-Up Converter with Logic Shutdown

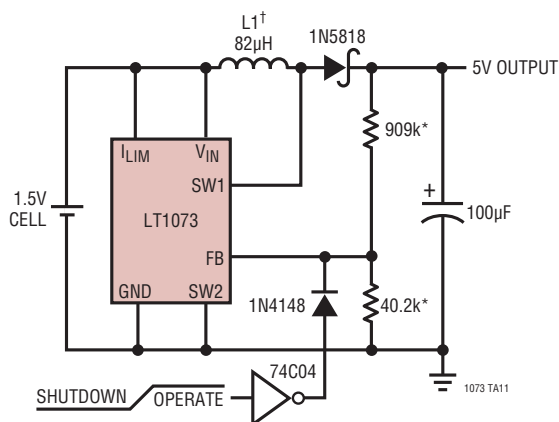

* 1% METAL FILM
 † L1 = GOWANDA GA10-822k
 OR CADDELL-BURNS 7300-12

1.5V to 5V Step-Up Converter with Low-Battery Detector

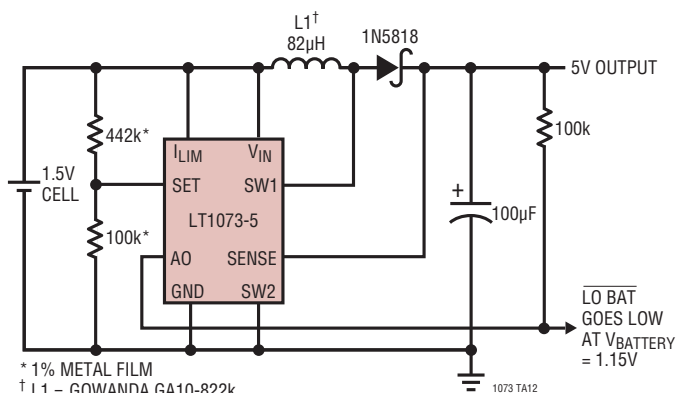

* 1% METAL FILM
 † L1 = GOWANDA GA10-822k
 OR CADDELL-BURNS 7300-12

9V to 3V Step-Down Converter

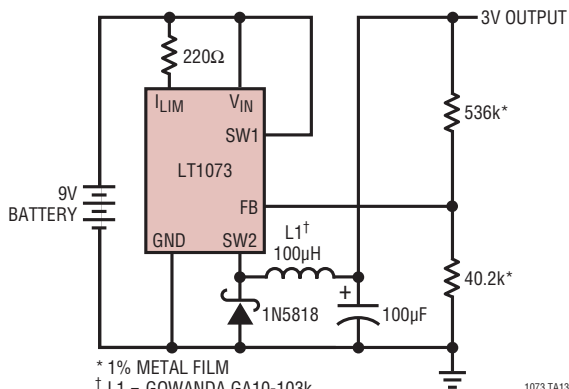

* 1% METAL FILM
 † L1 = GOWANDA GA10-103k
 OR CADDELL-BURNS 7300-13

9V to 5V Step-Down Converter

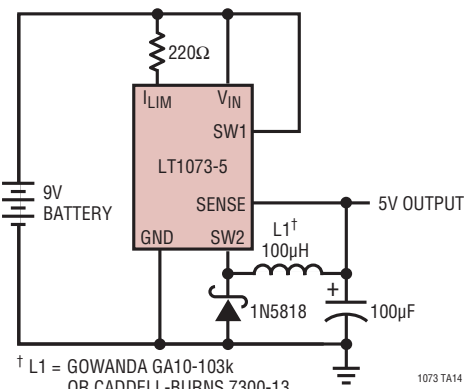

† L1 = GOWANDA GA10-103k
 OR CADDELL-BURNS 7300-13

1.5V to 5V Bootstrapped Step-Up Converter

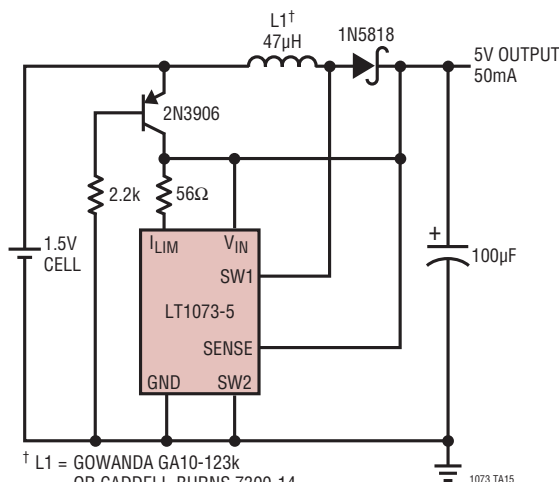

† L1 = GOWANDA GA10-123k
 OR CADDELL-BURNS 7300-14
 MINIMUM START-UP VOLTAGE = 1.1V

Memory Backup Supply

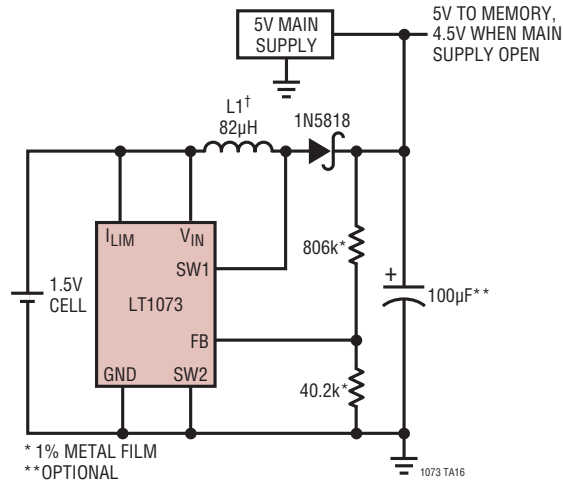

* 1% METAL FILM
 **OPTIONAL
 † L1 = GOWANDA GA10-822k
 OR CADDELL-BURNS 7300-12

TYPICAL APPLICATIONS

3V to 5V Step-Up Converter with Undervoltage Lockout

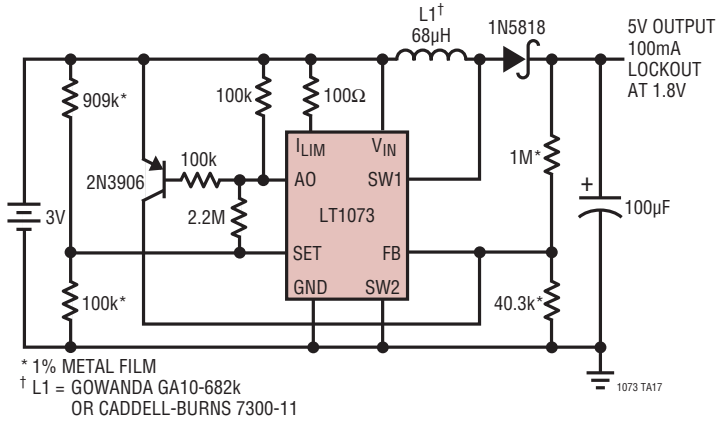

1.5V to 5V Low Noise Step-Up Converter

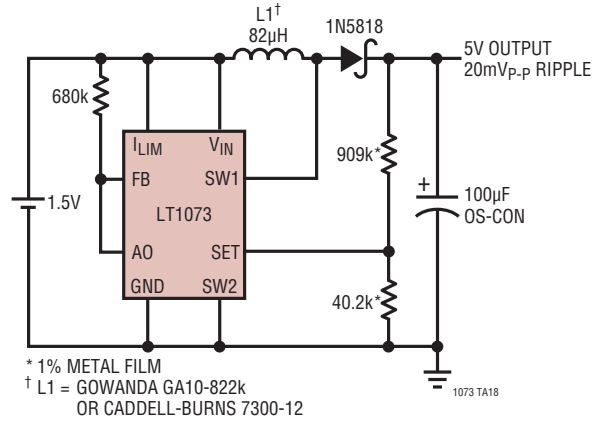

1.5V to 5V Very Low Noise Step-Up Converter

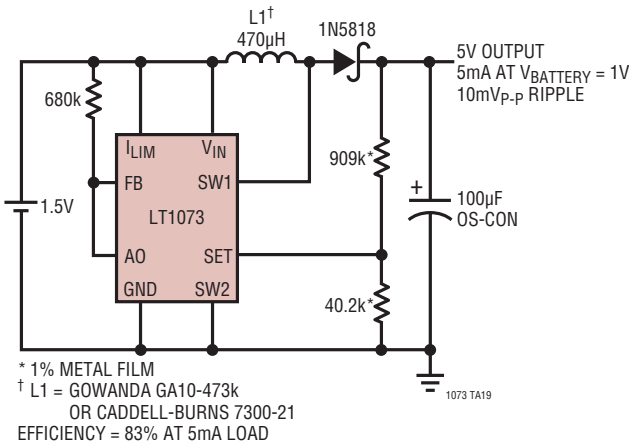

9V to 5V Reduced Noise Step-Down Converter

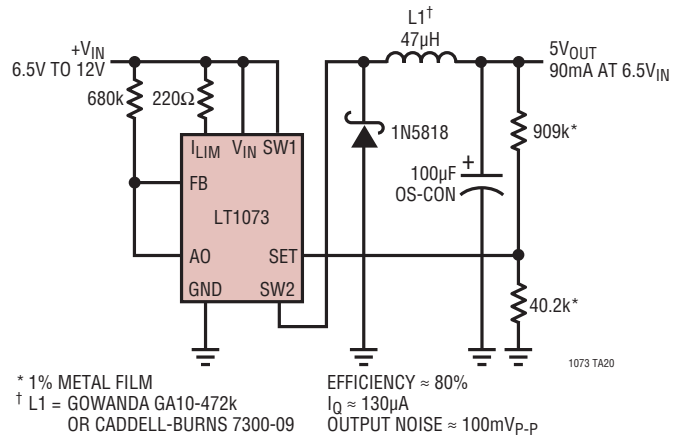

3V to 6V at 1A Step-Up Converter

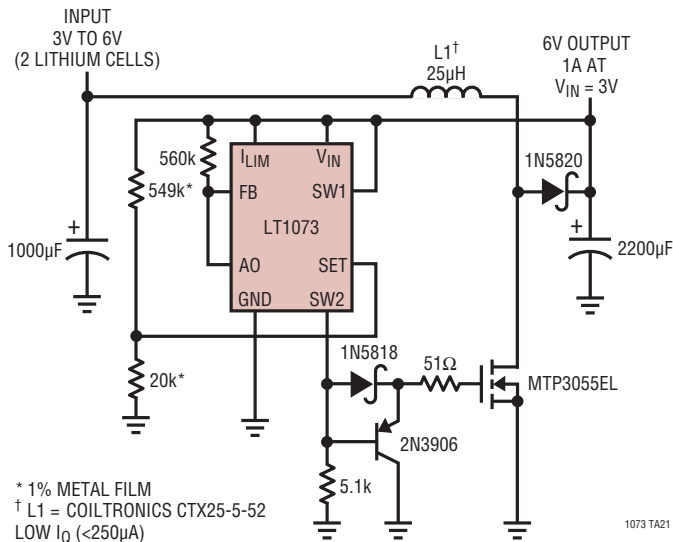

1.5V Powered 350ps Risetime Pulse Generator

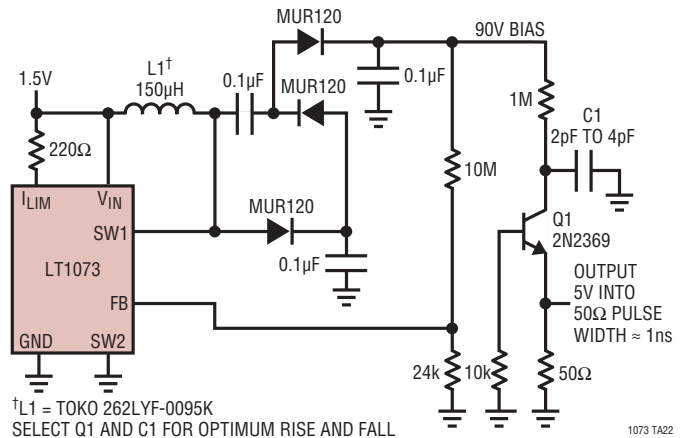

PACKAGE DESCRIPTION Dimensions in inches (millimeters) unless otherwise noted.

N8 Package
8-Lead PDIP (Narrow 0.300)
 (LTC DWG # 05-08-1510)

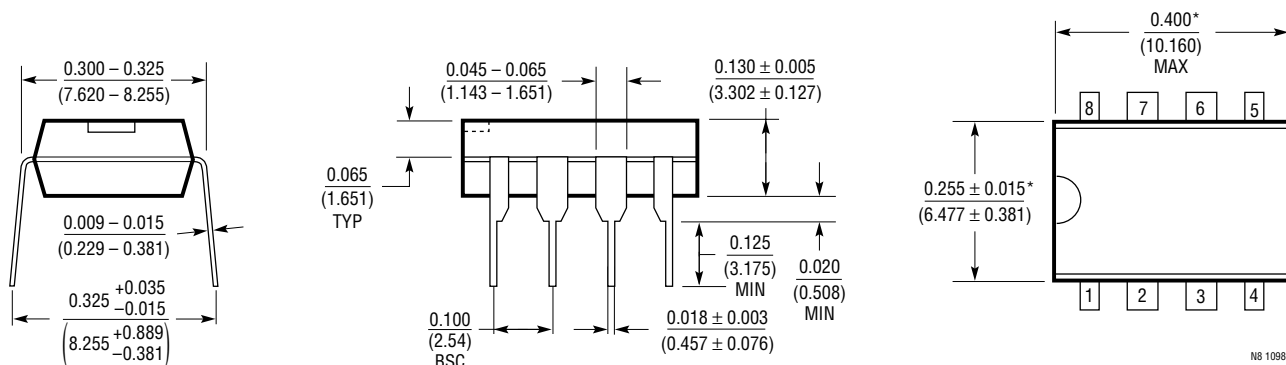

*THESE DIMENSIONS DO NOT INCLUDE MOLD FLASH OR PROTRUSIONS.
 MOLD FLASH OR PROTRUSIONS SHALL NOT EXCEED 0.010 INCH (0.254mm)

S8 Package
8-Lead Plastic Small Outline (Narrow 0.150)
 (LTC DWG # 05-08-1610)

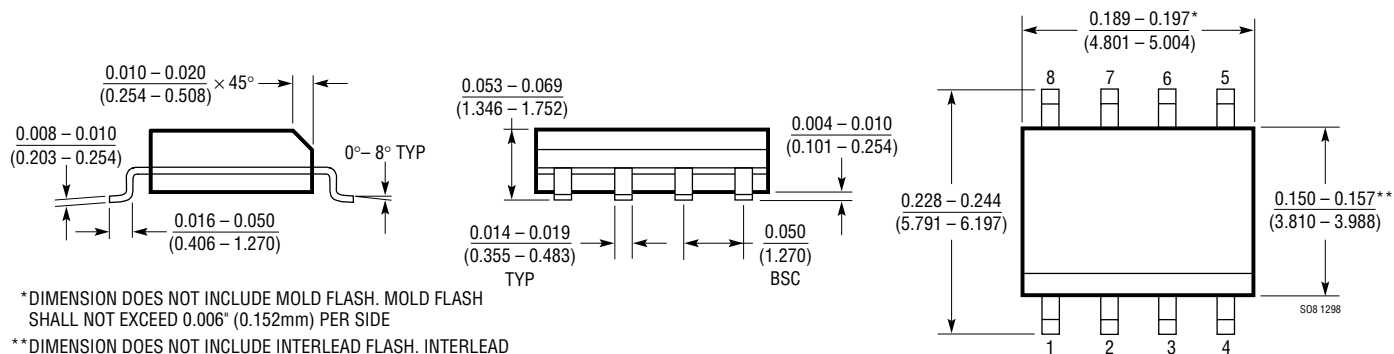

DIMENSION DOES NOT INCLUDE MOLD FLASH. MOLD FLASH SHALL NOT EXCEED 0.006 (0.152mm) PER SIDE
 **DIMENSION DOES NOT INCLUDE INTERLEAD FLASH. INTERLEAD FLASH SHALL NOT EXCEED 0.010* (0.254mm) PER SIDE

TYPICAL APPLICATION

1.5V Powered Temperature Compensated Crystal Oscillator

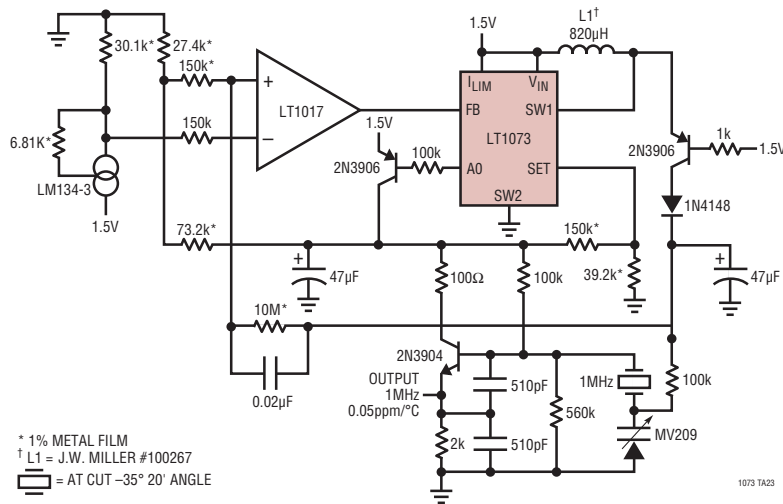

1.5V Powered α , β , γ Particle Detector

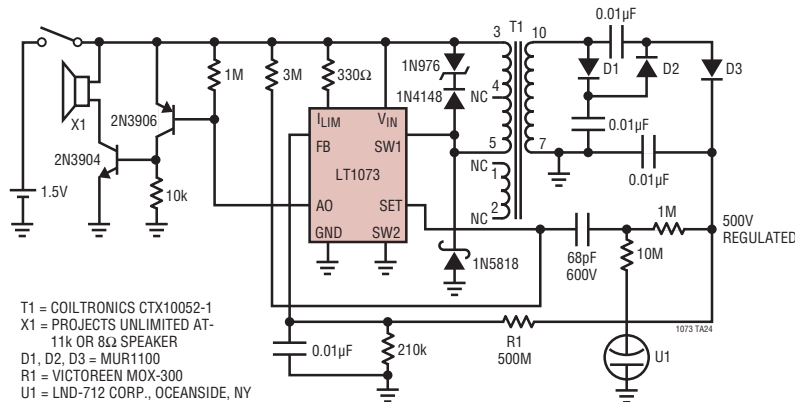

RELATED PARTS

PART NUMBER	DESCRIPTION	COMMENTS
LT1307	Single Cell Micropower 600kHz PWM DC/DC Converter	3.3V at 75mA from One Cell, MSOP Package
LT1316	Burst Mode™ Operation DC/DC with Programmable Current Limit	1.5V Minimum, Precise Control of Peak Current Limit
LT1317	2-Cell Micropower DC/DC with Low-Battery Detector	3.3V at 200mA from Two Cells, 600kHz Fixed Frequency
LT1610	Single Cell Micropower DC/DC Converter	3V at 30mA from 1V, 1.7MHz Fixed Frequency
LT1611	Inverting 1.4MHz Switching Regulator in 5-Lead SOT-23	-5V at 150mA from 5V Input, Tiny SOT-23 Package
LT1613	1.4MHz Switching Regulator in 5-Lead SOT-23	5V at 200mA from 3.3V Input, Tiny SOT-23 Package
LT1615	Micropower Constant Off-Time DC/DC Converter in 5-Lead SOT-23	20V at 12mA from 2.5V, Tiny SOT-23 Package
LT1617	Micropower Inverting DC/DC Converter in 5-Lead SOT-23	-15V at 12mA from 2.5V, Tiny SOT-23 Package
LT1930/LT1930A	1.2MHz/2.2MHz, 1A Switching Regulator in 5-Lead SOT-23	5V at 450mA from 3.3V Input, Tiny SOT-23 Package
LT1931/LT1931A	1.2MHz/2.2MHz, 1A Inverting Switching Regulator in 5-Lead SOT-23	-5V at 350mA from 5V Input, Tiny SOT-23 Package

Burst Mode operation is a trademark of Linear Technology Corporation.

X-ON Electronics

Largest Supplier of Electrical and Electronic Components

Click to view similar products for [Switching Voltage Regulators](#) category:

Click to view products by [Analog Devices](#) manufacturer:

Other Similar products are found below :

[FAN53610AUC33X](#) [FAN53611AUC123X](#) [FAN48610BUC33X](#) [FAN48610BUC45X](#) [FAN48617UC50X](#) [R3](#) [430464BB](#) [KE177614](#)
[FAN53611AUC12X](#) [MAX809TTR](#) [NCV891234MW50R2G](#) [NCP81103MNTXG](#) [NCP81203PMNTXG](#) [NCP81208MNTXG](#)
[NCP81109GMNTXG](#) [SCY1751FCCT1G](#) [NCP81109JMNTXG](#) [AP3409ADNTR-G1](#) [NCP81241MNTXG](#) [LTM8064IY](#) [LT8315EFE#TRPBF](#)
[LTM4664EY#PBF](#) [LTM4668AIY#PBF](#) [NCV1077CSTBT3G](#) [XCL207A123CR-G](#) [MPM54304GMN-0002](#) [MPM54304GMN-0004](#)
[MPM54304GMN-0003](#) [AP62300Z6-7](#) [MP8757GL-P](#) [MIC23356YFT-TR](#) [LD8116CGL](#) [HG2269M/TR](#) [OB2269](#) [XD3526](#) [U6215A](#) [U6215B](#)
[U6620S](#) [LTC3412IFE](#) [LT1425IS](#) [MAX25203BATJA/VY+](#) [MAX77874CEWM+](#) [XC9236D08CER-G](#) [MP3416GJ-P](#) [MP5461GC-Z](#)
[MPQ4415AGQB-Z](#) [MPQ4590GS-Z](#) [MAX38640BENT18+T](#) [MAX77511AEWB+](#) [MAX20406AFOD/VY+](#)