

Constant-Current/Voltage High Efficiency Battery Charger

FEATURES

- Simple Charging of Li-Ion, NiMH and NiCd Batteries
- Very High Efficiency: Up to 97%
- Precision 0.5% Charging Voltage Accuracy
- Preset Battery Voltages: 12.3V, 12.6V, 16.4V and 16.8V
- 5% Charging Current Accuracy
- Charging Current Programmed by Resistor or DAC
- 0.5V Dropout Voltage, Duty Cycle > 99.5%
- AC Adapter Current Limit* Maximizes Charging Rate
- Flag Indicates Li-Ion Charge Completion
- Auto Shutdown with Adapter Removal
- Only 10 μ A Battery Drain When Idle
- Synchronizable Up to 280kHz

APPLICATIONS

- Notebook Computers
- Portable Instruments
- Chargers for Li-Ion, NiMH, NiCd and Lead Acid Rechargeable Batteries

DESCRIPTION

The LT[®]1505 PWM battery charger controller fast charges multiple battery chemistries including lithium-ion (Li-Ion), nickel-metal-hydride (NiMH) and nickel-cadmium (NiCd) using constant-current or constant-voltage control. Maximum current can be easily programmed by resistors or a DAC. The constant-voltage output can be selected for 3 or 4 series Li-Ion cells with 0.5% accuracy.

A third control loop limits the current drawn from the AC adapter during charging*. This allows simultaneous operation of the equipment and fast battery charging without overloading the AC adapter.

The LT1505 can charge batteries ranging from 2.5V to 20V with dropout voltage as low as 0.5V. Synchronous N-channel FETs switching at 200kHz give high efficiency and allow small inductor size. A diode is not required in series with the battery because the charger automatically enters a 10 μ A sleep mode when the wall adapter is unplugged. A logic output indicates Li-Ion full charge when current drops to 20% of the programmed value.

The LT1505 is available in a 28-pin SSOP package.

 LTC and LT are registered trademarks of Linear Technology Corporation.
 *US Patent No. 5,723,970

TYPICAL APPLICATION

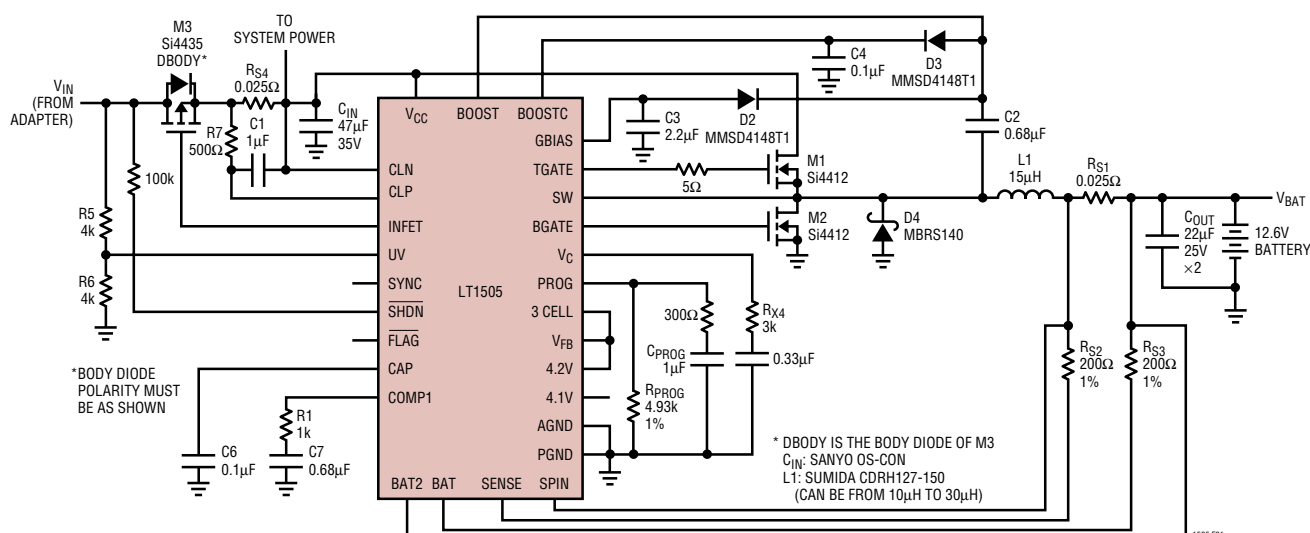

Figure 1. Low Dropout 4A Lithium-Ion Battery Charger

ABSOLUTE MAXIMUM RATINGS (Note 1)

V_{CC} , CLP, CLN, INFET, UV, 3CELL, \overline{FLAG}	27V	TGATE, BGATE Current Continuous	0.2A
SW Voltage with Respect to GND	-2V	TGATE, BGATE Output Energy (per cycle)	2 μ J
BOOST, BOOSTC Voltage with Respect to V_{CC}	10V	Maximum Operating V_{CC}	24V
GBIAS	10V	Operating Ambient Temperature Range	0°C to 70°C
SYNC, BAT2, BAT, SENSE, SPIN	20V	Operating Junction Temperature Range	0°C to 125°C
V_C , PROG, V_{FB} , 4.1V, 4.2V	7V	Storage Temperature Range	-65°C to 150°C
CAP, SHDN	± 3 mA	Lead Temperature (Soldering, 10 sec)	300°C

PACKAGE/ORDER INFORMATION

<p>TOP VIEW</p> <p>G PACKAGE 28-LEAD PLASTIC SSOP $T_{JMAX} = 125^{\circ}\text{C}$, $\theta_{JA} = 100^{\circ}\text{C/W}$</p>	<p>ORDER PART NUMBER</p> <p>LT1505CG</p>	<p>TOP VIEW</p> <p>G PACKAGE 28-LEAD PLASTIC SSOP $T_{JMAX} = 125^{\circ}\text{C}$, $\theta_{JA} = 100^{\circ}\text{C/W}$</p>	<p>ORDER PART NUMBER</p> <p>LT1505CG-1</p> <p>NOTE: LT1505CG-1 DOES NOT HAVE INPUT CURRENT LIMITING FUNCTION.</p>
---	--	---	--

Consult LTC Marketing for parts specified with wider operating temperature ranges.

ELECTRICAL CHARACTERISTICS

The ● denotes specifications which apply over the full operating temperature range, otherwise specifications are at $T_A = 25^{\circ}\text{C}$. $V_{CC} = 18\text{V}$, $V_{BAT} = 12.6\text{V}$, $V_{CLN} = V_{CC}$ (LT1505), no load on any outputs unless otherwise noted.

PARAMETER	CONDITIONS	MIN	TYP	MAX	UNITS	
Overall						
Supply Current	$V_{CC} \leq 24\text{V}$	●	12	15	mA	
Sense Amplifier CA1 Gain and Input Offset Voltage (With $R_{S2} = 200\Omega$, $R_{S3} = 200\Omega$) (Measured across R_{S1} , Figure 1) (Note 2)	$11\text{V} \leq V_{CC} \leq 24\text{V}$, $0\text{V} \leq V_{BAT} \leq 20\text{V}$ $R_{PROG} = 4.93\text{k}$		95	100	105	mV
	$R_{PROG} = 4.93\text{k}$	●	92	100	108	mV
	$R_{PROG} = 49.3\text{k}$		7	10	13	mV
BOOST Pin Current	$V_{BOOST} = V_{SW} + 8\text{V}$, $0\text{V} \leq V_{SW} \leq 20\text{V}$ TGATE High TGATE Low		2	3	mA	
			2	3	mA	
BOOSTC Pin Current	$V_{BOOSTC} = V_{CC} + 8\text{V}$		1		mA	
Reference						
Reference Voltage (Note 3)	$R_{PROG} = 4.93\text{k}$, Measured at V_{FB} with V_A Supplying I_{PROG} and Switching Off		2.453	2.465	2.477	V
Reference Voltage Tolerance	$11\text{V} \leq V_{CC} \leq 24\text{V}$	●	2.441	2.489	V	

ELECTRICAL CHARACTERISTICS The ● denotes specifications which apply over the full operating temperature range, otherwise specifications are at $T_A = 25^\circ\text{C}$. $V_{CC} = 18\text{V}$, $V_{BAT} = 12.6\text{V}$, $V_{CLN} = V_{CC}$ (LT1505), no load on any outputs unless otherwise noted.

PARAMETER	CONDITIONS		MIN	TYP	MAX	UNITS
Preset Battery Voltage (12.3V, 16.4V, 12.6V, 16.8V)						
All Preset Battery Voltages	Measured at BAT2 Pin			0.5		%
Preset Battery Voltage Tolerance	$(V_{BAT} + 0.3\text{V}) \leq V_{CC} \leq 24\text{V}$	●	-1		1	%
BAT2 Pin Input Current	$V_{BAT2} = V_{PRESET} - 1\text{V}$	●			6	μA
Voltage Setting Resistors Tolerance (R4, R5, R6, R7)			-40		40	%
Shutdown						
Undervoltage Lockout (TGATE and BGATE "Off") Threshold (Note 9)	Measured at UV Pin	●	6.3	6.7	7.25	V
UV Pin Input Current	$0\text{V} \leq V_{UV} \leq 8\text{V}$	●	-1		5	μA
Reverse Current from Battery in Micropower Shutdown (Note 10)	$V_{BAT} \leq 20\text{V}$, $V_{UV} \leq 0.4\text{V}$, $V_{CC} = V_{SW} = \text{Battery Voltage}$			10	50	μA
Shutdown Threshold at $\overline{\text{SHDN}}$ Pin When V_{CC} is Connected		●	1		2	V
$\overline{\text{SHDN}}$ Pin Current	$0\text{V} \leq V_{\overline{\text{SHDN}}} \leq 3\text{V}$				8	μA
Supply Current in Shutdown ($V_{\overline{\text{SHDN}}}$ is Low, V_{CC} is Connected)	$V_{CC} \leq 24\text{V}$			15	20	mA
Minimum I_{PROG} for Switching "On"			-1	-4	-22	μA
Minimum I_{PROG} for Switching "Off" at $V_{\text{PROG}} \leq 1\text{V}$		●	-1	-2.4		mA
Current Sense Amplifier CA1 Inputs (SENSE, BAT)						
Input Bias Current (SENSE, BAT)	$V_{\overline{\text{SHDN}}} = \text{High}$ $V_{\overline{\text{SHDN}}} = \text{Low (Shutdown)}$	●		-50	-120 -10	μA μA
Input Common Mode Low		●	-0.25			V
Input Common Mode High		●			$V_{CC} - 0.3$	V
SPIN Input Current	$V_{\overline{\text{SHDN}}} = \text{High}$, $V_{\text{SPIN}} \geq 2\text{V}$ (Note 8) $V_{\overline{\text{SHDN}}} = \text{Low (Shutdown)}$	●			2 10	mA μA
Oscillator						
Switching Frequency (f_{NOM})			180	200	220	kHz
Switching Frequency Tolerance		●	170	200	230	kHz
SYNC Pin Input Current	$V_{\text{SYNC}} = 0\text{V}$ $V_{\text{SYNC}} = 2\text{V}$				-0.5 -30	mA μA
Synchronization Pulse Threshold on SYNC Pin			0.9	1.2	2.0	V
Synchronization Frequency		●	240		280	kHz
Maximum Duty Cycle						
V_{BOOST} Threshold to Turn TGATE Off (Comparator A2) (Note 4)	Measured at $(V_{\text{BOOST}} - V_{\text{SW}})$ Low to High Hysteresis	●	6.8	7.3 0.25	7.6	V V
Maximum Duty Cycle of Natural Frequency 200kHz (Note 5)		●	85	90		%
Current Amplifier CA2						
Transconductance	$V_C = 1\text{V}$, $I_{V_C} = \pm 1\mu\text{A}$		150	200	300	μmho
Maximum V_C for Switch Off		●			0.6	V
I_{V_C} Current (Out of Pin)	$V_C \geq 0.6\text{V}$ $V_C < 0.45\text{V}$	● ●			50 3	μA mA
V_C at Shutdown	$V_{\overline{\text{SHDN}}} = \text{Low (Shutdown)}$	●			0.35	V

1505fc

ELECTRICAL CHARACTERISTICS The ● denotes specifications which apply over the full operating temperature range, otherwise specifications are at $T_A = 25^\circ\text{C}$. $V_{CC} = 18\text{V}$, $V_{BAT} = 12.6\text{V}$, $V_{CLN} = V_{CC}$ (LT1505), no load on any outputs unless otherwise noted.

PARAMETER	CONDITIONS	MIN	TYP	MAX	UNITS	
Voltage Amplifier VA						
Transconductance (Note 3)	Output Current from 50 μA to 500 μA	0.21	0.6	1.0	mho	
Output Source Current	$V_{FB} = V_{PROG} = V_{REF} + 10\text{mV}$	1.1			mA	
V_{FB} Input Bias Current	At 0.5mA VA Output Current, $T_A < 70^\circ\text{C}$ (3 CELL, 4.1V, 4.2V Are Not Connected, $V_{BAT2} = 0\text{V}$)	-10		25	nA	
Current Limit Amplifier CL1						
Turn-On Threshold	0.5mA Output Current	87	92	97	mV	
Transconductance	Output Current from 50 μA to 500 μA	0.5	1	3	mho	
CLP Input Current	0.5mA Output Current		1	3	μA	
CLN Input Current	0.5mA Output Current		0.8	2	mA	
Input P-Channel FET Driver (INFET)						
INFET "On" Clamping Voltage ($V_{CC} - V_{INFET}$)	$V_{CC} \geq 11\text{V}$	● 6.5	7.8	9	V	
INFET "On" Driver Current	$V_{INFET} = V_{CC} - 6\text{V}$	● 8	20		mA	
INFET "Off" Clamping Voltage ($V_{CC} - V_{INFET}$)	V_{CC} Not Connected, $I_{INFET} < -2\mu\text{A}$			1.4	V	
INFET "Off" Drive Current	V_{CC} Not Connected, $(V_{CC} - V_{INFET}) \geq 2\text{V}$		-2.5		mA	
Charging Completion Flag (Comparator E6)						
Charging Completion Threshold (Note 6)	Measured at V_{RS1} , $V_{CAP} = 2\text{V}$ (Note 7)	14	20	28	mV	
Threshold On CAP Pin	Low to High Threshold	●	3.3	4.2	V	
	High to Low Threshold	● 0.6			V	
V_{CAP} at Shutdown	$V_{SHDN} = \text{Low}$ (Shutdown)	●	0.13	0.3	V	
$\overline{\text{FLAG}}$ (Open Collector) Output Low	$V_{CAP} = 4\text{V}$, $I_{\overline{\text{FLAG}}} < 1\text{mA}$	●		0.3	V	
$\overline{\text{FLAG}}$ Pin Leakage Current	$V_{CAP} = 0.6\text{V}$	●		3	μA	
Gate Drivers (TGATE, BGATE)						
V_{GBIAS}	$11\text{V} < V_{CC} < 24\text{V}$, $I_{GBIAS} \leq 15\text{mA}$ $V_{SHDN} = \text{Low}$ (Shutdown)	●	8.4	9.1	9.6	V
		●		1	3	V
V_{TGATE} High ($V_{TGATE} - V_{SW}$)	$I_{TGATE} \leq 20\text{mA}$, $V_{BOOST} = V_{GBIAS} - 0.5\text{V}$	●	5.6	6.6		V
V_{BGATE} High	$I_{BGATE} \leq 20\text{mA}$	●	6.2	7.2		V
V_{TGATE} Low ($V_{TGATE} - V_{SW}$)	$I_{TGATE} \leq 50\text{mA}$	●			0.8	V
V_{BGATE} Low	$I_{BGATE} \leq 50\text{mA}$	●			0.8	V
Peak Gate Drive Current	10nF Load			1	A	
Gate Drive Rise and Fall Time	1nF Load			25	ns	
V_{TGATE} , V_{BGATE} at Shutdown	$V_{SHDN} = \text{Low}$ (Shutdown) $I_{TGATE} = I_{BGATE} = 10\mu\text{A}$	●			1	V

Note 1: Absolute Maximum Ratings are those values beyond which the life of a device may be impaired.

Note 2: Tested with Test Circuit 1.

Note 3: Tested with Test Circuit 2.

Note 4: When V_{CC} and battery voltage differential is low, high duty factor is required. The LT1505 achieves a duty factor greater than 99% by skipping cycles. Only when V_{BOOST} drops below the comparator A2 threshold will TGATE be turned off. See Applications Information.

Note 5: When the system starts, C2 (boost cap) has to be charged up to drive TGATE and to start the system. The LT1505 will keep TGATE off and turn BGATE on for 0.2 μs at 200kHz to charge up C2. Comparator A2 senses V_{BOOST} and switches to the normal PWM mode when V_{BOOST} is above the threshold.

Note 6: See "Lithium-Ion Charging Completion" in the Applications Information Section.

Note 7: Tested with Test Circuit 3.

Note 8: I_{SPIN} keeps switching on to keep V_{BAT} regulated when battery is not present to avoid high surge current from C_{OUT} when battery is inserted.

Note 9: Above undervoltage threshold switching is enabled.

Note 10: Do not connect V_{CC} directly to V_{IN} (see Figure 1). This connection will cause the internal diode between V_{BAT} and V_{CC} to be forward-biased and may cause high current to flow from V_{IN} . When the adapter is removed, V_{CC} will be held up by the body diode of M1.

TYPICAL PERFORMANCE CHARACTERISTICS

Efficiency of Figure 1 Circuit

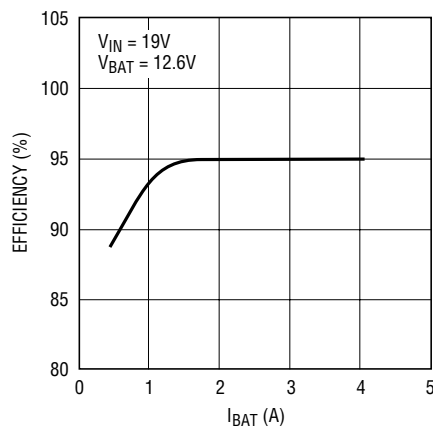

1505 G01

VGBIAS vs IGBIAS

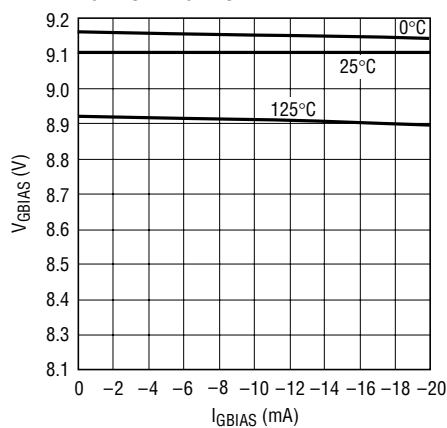

1505 G02

VREF Line Regulation

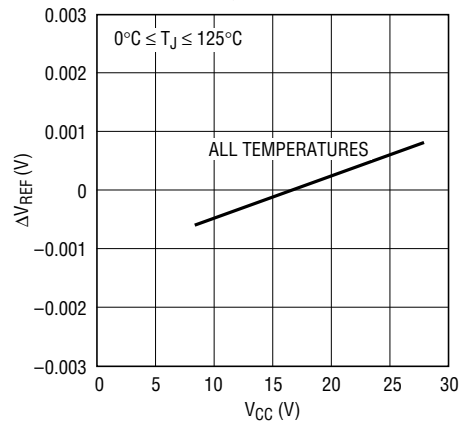

1505 G03

ΔVFB vs IVA (Voltage Amplifier)

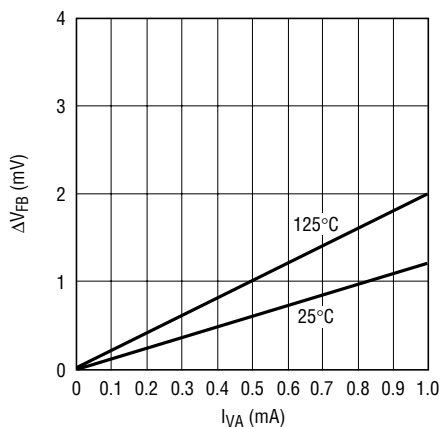

1505 G04

Current Limit Amplifier CL1 Threshold

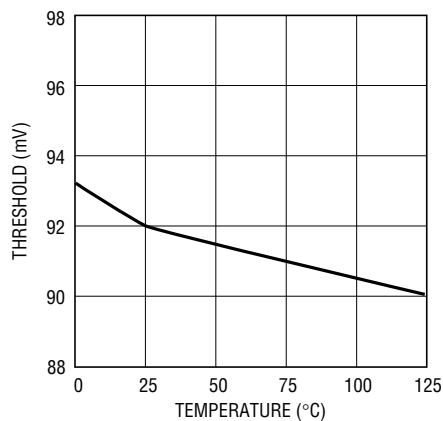

1505 G05

ICC vs VCC

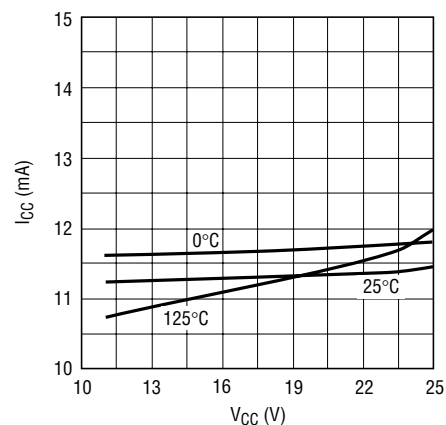

1505 G06

PROG Pin Characteristics

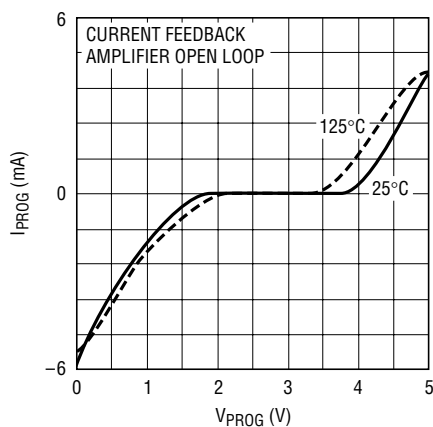

1505 G07

VC Pin Characteristics

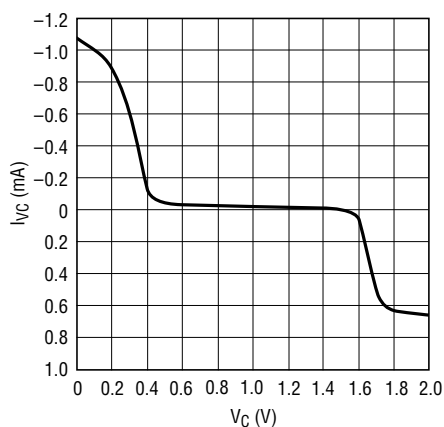

1505 G08

Reference Voltage vs Temperature

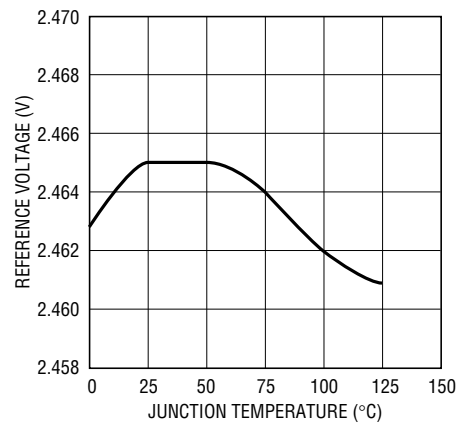

1505 G09

PIN FUNCTIONS

BOOST (Pin 1): This pin is used to bootstrap and supply power for the topside power switch gate drive and control circuitry. In normal operation, V_{BOOST} is powered from an internally generated 8.6V regulator V_{GBIAS} , $V_{\text{BOOST}} \approx V_{\text{CC}} + 9.1\text{V}$ when TGATE is high. Do not force an external voltage on BOOST pin.

TGATE (Pin 2): This pin provides gate drive to the topside power FET. When TGATE is driven on, the gate voltage will be approximately equal to $V_{\text{SW}} + 6.6\text{V}$. A series resistor of 5Ω to 10Ω should be used from this pin to the gate of the topside FET.

SW (Pin 3): This pin is the reference point for the floating topside gate drive circuitry. It is the common connection for the top and bottom side switches and the output inductor. This pin switches between ground and V_{CC} with very high dv/dt rates. Care needs to be taken in the PC layout to keep this node from coupling to other sensitive nodes. A 1A Schottky clamp diode should be placed from this pin to the ground pin, using very short traces to prevent the chip substrate diode from turning on. See Applications Information for more details.

SYNC (Pin 4): Synchronization Input. The LT1505 can be synchronized to an external clock with pulses that have duty cycles between 10% and 95%. An internal one shot that is triggered on the rising edge of the sync pulse makes this input insensitive to the duty cycle of the sync pulse. The input voltage range on this pin is 0V to 20V. This pin can float if not used.

SHDN (Pin 5): Shutdown. When this pin is pulled below 1V, switching will stop, GBIAS will go low and the input currents of CA1 will be off. Note that input current of about $4\mu\text{A}$ keeps the device in shutdown unless an external pull-up signal is applied. The voltage range on this pin is 0V to V_{CC} .

AGND (Pin 6): Low Current Analog Ground.

UV (Pin 7): Undervoltage Lockout Input. The rising threshold is 6.7V with a hysteresis of 0.5V. Switching stops in undervoltage lockout. When the input supply (normally the wall adapter output) to the chip is removed, the UV pin must be pulled down to below 0.7V (a 5k resistor from adapter output to GND is required), otherwise the reverse-battery current will be approximately $200\mu\text{A}$ instead of $10\mu\text{A}$. Do not leave the UV pin floating. If it is connected

to V_{IN} with no resistor divider, the built-in 6.7V undervoltage lockout will be effective. Maximum voltage allowed on this pin is V_{CC} .

INFET (Pin 8): For very low dropout applications, an external P-channel MOSFET can be used to connect the input supply to V_{CC} . This pin provides the gate drive for the PFET. The gate drive is clamped to 8V below V_{CC} . The gate is driven on (low) when $V_{\text{CC}} > (V_{\text{BAT}} + 0.2\text{V})$ and $V_{\text{UV}} > 6.7\text{V}$. The gate is off (high) when $V_{\text{CC}} < (V_{\text{BAT}} + 0.2\text{V})$. The body diode of the PFET is used to pull up V_{CC} to turn on the LT1505.

CLP (Pin 9): LT1505: Positive Input to the Input Current Limit Amplifier CL1. The threshold is set at 92mV. When used to limit input current, a filter is needed to filter out the 200kHz switching noise. (LT1505-1: No Connection.)

CLN (Pin 10): LT1505: Negative Input to the Input Current Limit Amplifier CL1. When used, both CLP and CLN should be connected to a voltage higher than 6V and normally V_{CC} (to the V_{CC} bypass capacitor for less noise). Maximum voltage allowed on both CLP and CLN is $V_{\text{CC}} + 1\text{V}$. (LT1505-1: No Connection.)

COMP1 (Pin 11): LT1505: Compensation Node for the Input Current Limit Amplifier CL1. At input adapter current limit, this pin rises to 1V. By forcing COMP1 low with an external transistor, amplifier CL1 will be disabled (no adapter current limit). Output current is less than 0.2mA. See the Figure 1 circuit for the required resistor and capacitor values. (LT1505-1: connect to GND.)

CAP (Pin 12): A $0.1\mu\text{F}$ capacitor from CAP to ground is needed to filter the sampled charging current signal. This filtered signal is used to set the $\overline{\text{FLAG}}$ pin when the charging current drops below 20% of the programmed maximum charging current.

FLAG (Pin 13): This pin is an open-collector output that is used to indicate the end of charge. The FLAG pin is driven low when the charge current drops below 20% of the programmed charge current. A pull-up resistor is required if this function is used. This pin is capable of sinking at least 1mA. Maximum voltage on this pin is V_{CC} .

4.1V (Pin 14), 4.2V (Pin 15), 3CELL (Pin 16), V_{FB} (Pin 17): These four pins are used to select the battery voltage using the preset internal resistor network. The V_{FB} pin is

PIN FUNCTIONS

the noninverting input to the amplifier, VA in the Block Diagram, that controls the charging current when the device operates in constant voltage mode. The amplifier VA controls the charging current to maintain the voltage on the V_{FB} pin at the reference voltage (2.465V). Input bias current for VA is approximately 3nA. The LT1505 incorporates a resistor divider that can be used to select the correct voltage for either three or four 4.1V or 4.2V lithium-ion cells. For three cells the 3CELL pin is shorted to the V_{FB} pin. For four cells the 3CELL pin is not connected. For 4.1V cells the 4.1V pin is connected to the V_{FB} pin and the 4.2V pin is not connected. For 4.2V cells the 4.2V pin is connected to V_{FB} and the 4.1V pin is not connected. See the table below.

PRESET BATTERY VOLTAGE	PIN SELECTION
12.3V (3 × 4.1V Cell)	4.1V, V _{FB} , 3CELL Short Together
16.4V (4 × 4.1V Cell)	4.1V, V _{FB} , Short Together, 3CELL Floats
12.6V (3 × 4.2V Cell)	4.2V, V _{FB} , 3CELL Short Together
16.8V (4 × 4.2V Cell)	4.2V, V _{FB} , Short Together, 3CELL Floats

For battery voltages other than the preset values, an external resistor divider can be used. If an external divider is used then the 4.1V, 4.2V and 3CELL pins should not be connected and BAT2 pin should be grounded. To maintain the tight voltage tolerance, the external resistors should have better than 0.25% tolerance. Note that the V_{FB} pin will float high and inhibit switching if it is left open.

V_C (Pin 18): This is the control signal of the inner loop of the current mode PWM. Switching starts at 0.9V, higher V_C corresponds to higher charging current in normal operation and reaches 1.1V at full charging current. A capacitor of at least 0.33μF to GND filters out noise and controls the rate of soft start. Pulling this pin low will stop switching. Typical output current is 60μA.

PROG (Pin 19): This pin is for programming the charge current and for system loop compensation. During normal operation, V_{PROG} stays at 2.465V. If it is shorted to GND or more than 1mA is drawn out of the pin, switching will stop. When a microprocessor controlled DAC is used to program charging current, it must be capable of sinking current at a compliance up to 2.465V.

BAT2 (Pin 20): This pin is used to connect the battery to the internal preset voltage setting resistor. An internal switch disconnects the internal divider from the battery when the device is in shutdown or when power is disconnected. This disconnect function eliminates the current drain due to the resistor divider. This pin should be connected to the positive node of the battery if the internal preset divider is used. This pin should be grounded if an external divider is used. Maximum input voltage on this pin is 20V.

SENSE (Pin 21): This pin is the noninverting input to the current amplifier CA1 in the Block Diagram. Typical bias current is -50μA.

SPIN (Pin 22): This pin is for the internal amplifier CA1 bias. It must be connected as shown in the application circuit.

BAT (Pin 23): Current Amplifier CA1 Inverting Input. Typical bias current is -50μA.

V_{CC} (Pin 24): Input Supply. For good bypass, a low ESR capacitor of 10μF or higher is required. Keep the lead length to a minimum. V_{CC} should be between 11V and 24V. Do not force V_{CC} below V_{BAT} by more than 1V with the battery present.

BOOSTC (Pin 25): This pin is used to bootstrap and supply the current sense amplifier CA1 for very low dropout condition. V_{CC} can be as low as only 0.4V above the battery voltage. A diode and a capacitor are needed to get the voltage from V_{BOOST}. If low dropout is not needed and V_{CC} is always 3V or higher than V_{BAT}, this pin can be left floating or tied to V_{CC}. Do not force this pin to a voltage lower than V_{CC}. Typical input current is 1mA.

GBIAS (Pin 26): This is the output of the internal 9.1V regulator to power the drivers and control circuits. This pin must be bypassed to a ground plane with a minimum of 2.2μF ceramic capacitor. Switching will stop when V_{GBIAS} drops below 7V.

BGATE (Pin 27): Low Side Power MOSFET Drive.

PGND (Pin 28): MOSFET Driver Power Ground. A solid system ground plane is very important. See the LT1505 Demo Manual for further information.

BLOCK DIAGRAM (LT1505)

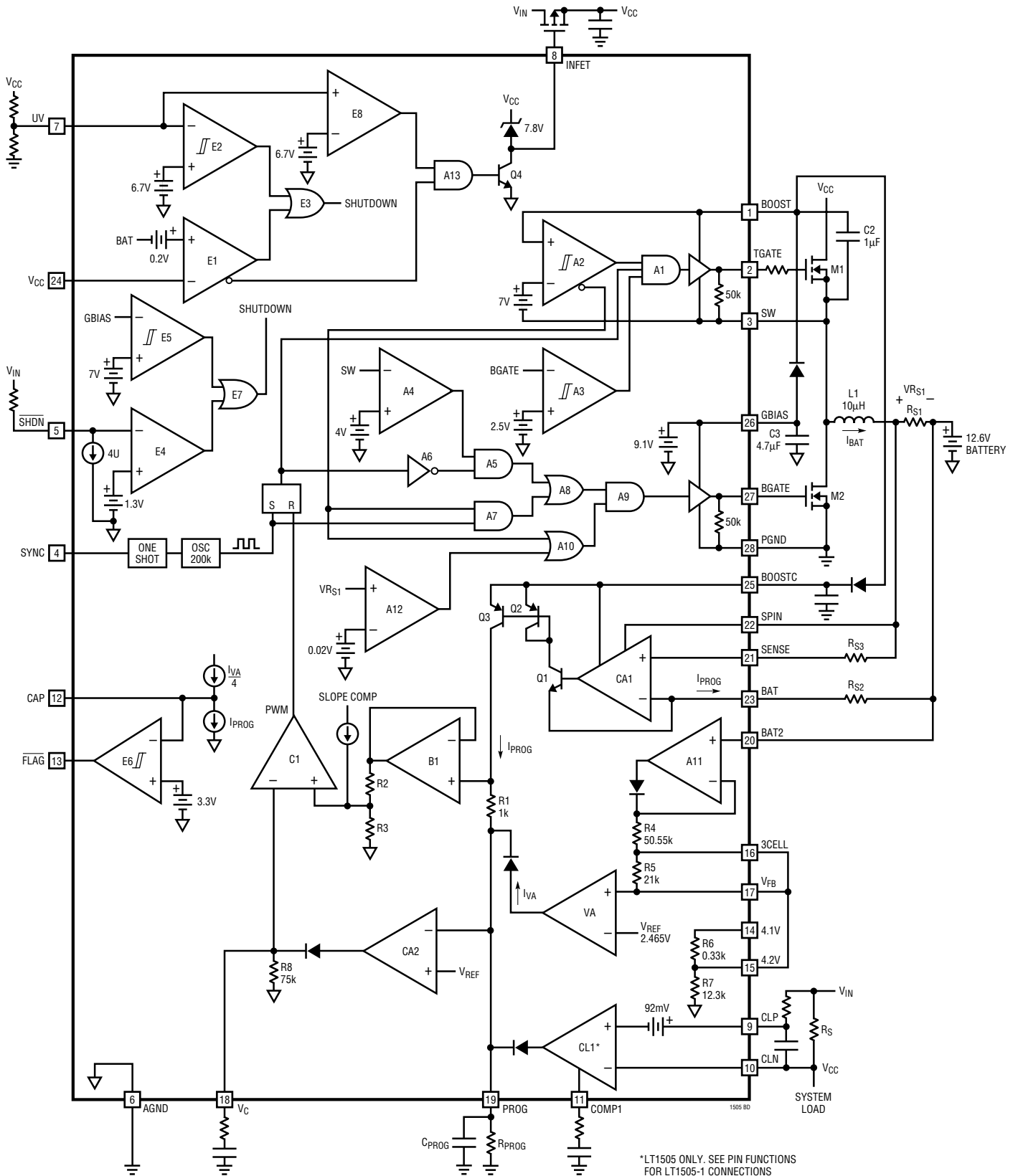

TEST CIRCUITS

Test Circuit 1

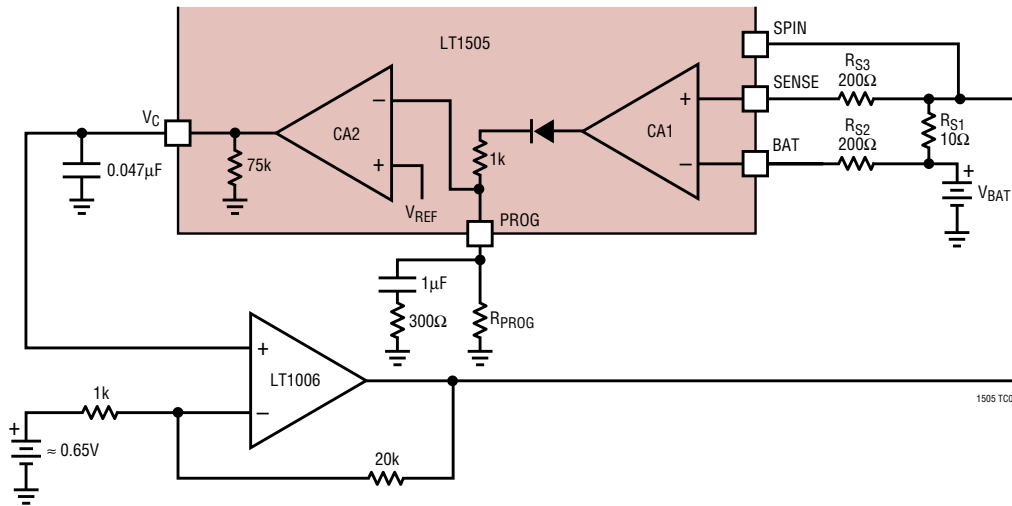

Test Circuit 2

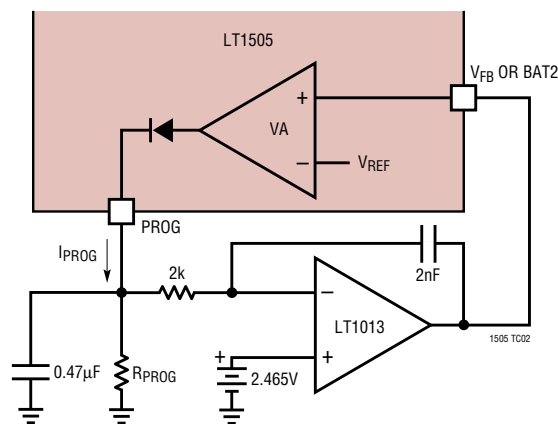

Test Circuit 3

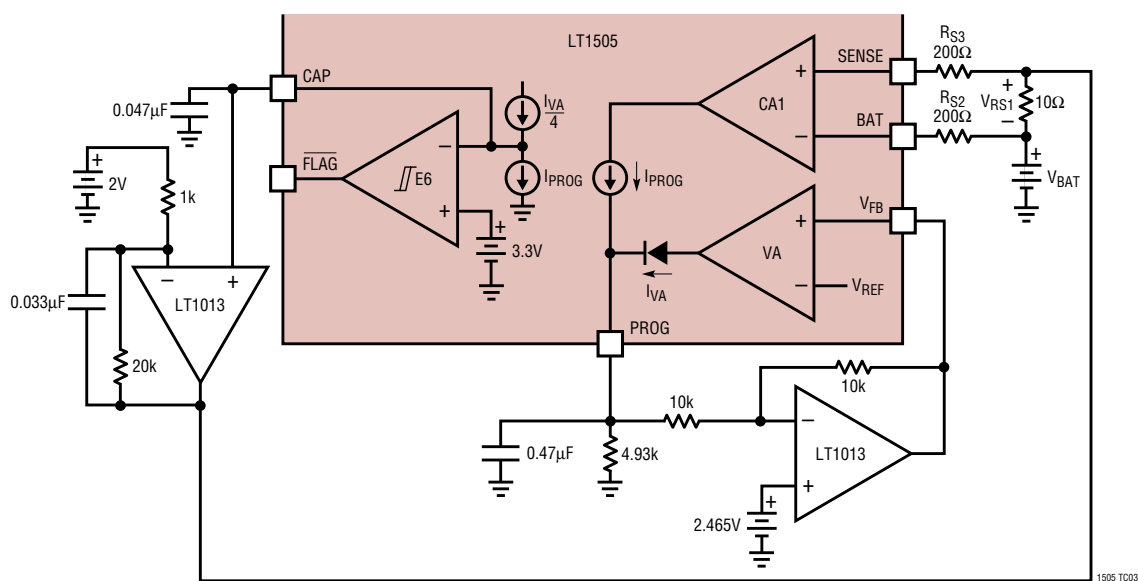

OPERATION

The LT1505 is a synchronous current mode PWM step-down (buck) switcher. The battery DC charge current is programmed by a resistor R_{PROG} (or a DAC output current) at the PROG pin and the ratio of sense resistors R_{S2} over R_{S1} (see Block Diagram). Amplifier CA1 converts the charge current through R_{S1} to a much lower current I_{PROG} ($I_{\text{PROG}} = I_{\text{BAT}} \cdot R_{\text{S1}}/R_{\text{S2}}$) fed into the PROG pin. Amplifier CA2 compares the output of CA1 with the programmed current and drives the PWM loop to force them to be equal. High DC accuracy is achieved with averaging capacitor C_{PROG} . Note that I_{PROG} has both AC and DC components. I_{PROG} goes through R1 and generates a ramp signal that is fed to the PWM control comparator C1 through buffer B1 and level shift resistors R2 and R3, forming the current mode inner loop. The BOOST pin supplies the topside power switch gate drive. The LT1505 generates an $9.1V V_{\text{GBIAS}}$ to power drives and V_{BOOSTC} . BOOSTC pin supplies the current amplifier CA1 with a voltage higher than V_{CC} for low dropout application. For batteries like lithium that require both constant-current and constant-voltage charging, the 0.5% 2.465V reference and the amplifier VA reduce the charge current when battery voltage reaches the preset level. For NiMH and NiCd, VA can be used for overvoltage protection.

The amplifier CL1 monitors and limits the input current, normally from the AC adapter, to a preset level ($92\text{mV}/R_{\text{S}}$).

At input current limit, CL1 will supply the programming current I_{PROG} , thus reducing battery charging current.

To prevent current shoot-through between topside and lowside switches, comparators A3 and A4 assure that one switch turns off before the other is allowed to turn on. Comparator A12 monitors charge current level and turns lowside switch off if it drops below 20% of the programmed value (20mV across R_{S1}) to allow for inductor discontinuous mode operation. Therefore sometimes even in continuous mode operation with light current level the lowside switch stays off.

Comparator E6 monitors the charge current and signals through the FLAG pin when the charger is in voltage mode and the charge current level is reduced to 20%. This charge complete signal can be used to start a timer for charge termination.

The INFET pin drives an external P-channel FET for low dropout application.

When input voltage is removed, V_{CC} will be held up by the body diode of the topside MOSFET. The LT1505 goes into a low current, $10\mu\text{A}$ typical, sleep mode as V_{CC} drops below the battery voltage. To shut down the charger simply pull the V_{C} pin or SHDN pin low with a transistor.

APPLICATIONS INFORMATION

Input and Output Capacitors

In the 4A Lithium Battery Charger (Figure 1), the input capacitor (C_{IN}) is assumed to absorb all input switching ripple current in the converter, so it must have adequate ripple current rating. Worst-case RMS ripple current will be equal to one half of output charging current. Actual capacitance value is not critical. Solid tantalum capacitors such as the AVX TPS and Sprague 593D series have high ripple current rating in a relatively small surface mount package, but *caution must be used when tantalum capacitors are used for input bypass*. High input surge currents can be created when the adapter is hot-plugged to the charger and solid tantalum capacitors have a known failure mechanism when subjected to very high turn-on surge currents. Highest possible voltage rating on the

capacitor will minimize problems. Consult the manufacturer before use. Alternatives include new high capacity ceramic (at least $20\mu\text{F}$) from Tokin or United Chemi-Con/Marcon, et al.

The output capacitor (C_{OUT}) is also assumed to absorb output switching current ripple. The general formula for capacitor current is:

$$I_{\text{RMS}} = \frac{0.29 (V_{\text{BAT}}) \left(1 - \frac{V_{\text{BAT}}}{V_{\text{CC}}}\right)}{(L1)(f)}$$

For example, $V_{\text{CC}} = 19\text{V}$, $V_{\text{BAT}} = 12.6\text{V}$, $L1 = 15\mu\text{H}$, and $f = 200\text{kHz}$, $I_{\text{RMS}} = 0.4\text{A}$.

APPLICATIONS INFORMATION

EMI considerations usually make it desirable to minimize ripple current in the battery leads. Beads or inductors may be added to increase battery impedance at the 200kHz switching frequency. Switching ripple current splits between the battery and the output capacitor depending on the ESR of the output capacitor and the battery impedance. If the ESR of C_{OUT} is 0.2Ω and the battery impedance is raised to 4Ω with a bead or inductor, only 5% of the ripple current will flow in the battery.

Soft Start and Undervoltage Lockout

The LT1505 is soft started by the $0.33\mu\text{F}$ capacitor on the V_C pin. On start-up, the V_C pin voltage will rise quickly to 0.5V , then ramp up at a rate set by the internal $45\mu\text{A}$ pull-up current and the external capacitor. Battery charge current starts ramping up when V_C voltage reaches 0.7V and full current is achieved with V_C at 1.1V . With a $0.33\mu\text{F}$ capacitor, time to reach full charge current is about 10ms and it is assumed that input voltage to the charger will reach full value in less than 10ms . The capacitor can be increased up to $1\mu\text{F}$ if longer input start-up times are needed.

In any switching regulator, conventional timer-based soft starting can be defeated if the input voltage rises much slower than the time out period. This happens because the switching regulators in the battery charger and the computer power supply are typically supplying a fixed amount of power to the load. If input voltage comes up slowly compared to the soft start time, the regulators will try to deliver full power to the load when the input voltage is still well below its final value. If the adapter is current limited, it cannot deliver full power at reduced output voltages and the possibility exists for a quasi “latch” state where the adapter output stays in a current limited state at reduced output voltage. For instance, if maximum charger plus computer load power is 30W , a 15V adapter might be current limited at 2.5A . If adapter voltage is less than $(30\text{W}/2.5\text{A} = 12\text{V})$ when full power is drawn, the adapter voltage will be pulled down by the constant 30W load until it reaches a lower stable state where the switching regulators can no longer supply full load. This situation can be prevented by setting *undervoltage lockout* higher than the minimum adapter voltage where full power can be achieved.

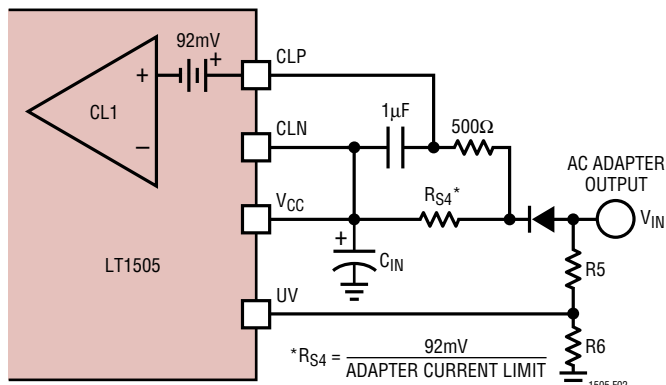

Figure 2. Adapter Current Limiting

A resistor divider is used to set the desired V_{CC} lockout voltage as shown in Figure 2. A typical value for R_6 is 5k and R_5 is found from:

$$R_5 = \frac{R_6(V_{IN} - V_{UV})}{V_{UV}}$$

V_{UV} = Rising lockout threshold on the UV pin

V_{IN} = Charger input voltage that will sustain full load power

Example: With $R_6 = 5\text{k}$, $V_{UV} = 6.7\text{V}$ and setting V_{IN} at 16V ;

$$R_5 = 5\text{k} (16\text{V} - 6.7\text{V}) / 6.7\text{V} = 6.9\text{k}$$

The resistor divider should be connected directly to the adapter output as shown, not to the V_{CC} pin to prevent battery drain with no adapter voltage. If the UV pin is not used, connect it to the adapter output (not V_{CC}) and connect a resistor no greater than 5k to ground. Floating the pin will cause reverse battery current to increase from $10\mu\text{A}$ to $200\mu\text{A}$.

Adapter Current Limiting (Not Applicable for the LT1505-1)

An important feature of the LT1505 is the ability to automatically adjust charge current to a level which avoids overloading the wall adapter. This allows the product to operate at the same time batteries are being charged without complex load management algorithms. Additionally, batteries will automatically be charged at the maximum possible rate of which the adapter is capable.

APPLICATIONS INFORMATION

This is accomplished by sensing total adapter output current and adjusting charge current downward if a preset adapter current limit is exceeded. True analog control is used, with closed loop feedback ensuring that adapter load current remains within limits. Amplifier CL1 in Figure 2 senses the voltage across R_{S4} , connected between the CLP and CLN pins. When this voltage exceeds 92mV, the amplifier will override programmed charge current to limit adapter current to $92\text{mV}/R_{S4}$. A lowpass filter formed by 500Ω and $1\mu\text{F}$ is required to eliminate switching noise. If the current limit is not used, then the R7 /C1 filter and the COMP1 (R1/C7) compensation networks are not needed, and both CLP and CLN pins should be connected to V_{CC} .

Charge Current Programming

The basic formula for charge current is (see Block Diagram):

$$I_{\text{BAT}} = I_{\text{PROG}} \left(\frac{R_{S2}}{R_{S1}} \right) = \left(\frac{2.465\text{V}}{R_{\text{PROG}}} \right) \left(\frac{R_{S2}}{R_{S1}} \right)$$

where R_{PROG} is the total resistance from PROG pin to ground.

For the sense amplifier CA1 biasing purpose, R_{S3} should have the same value as R_{S2} and SPIN should be connected directly to the sense resistor (R_{S1}) as shown in the Block Diagram.

For example, 4A charging current is needed. For low power dissipation on R_{S1} and enough signal to drive the amplifier CA1, let $R_{S1} = 100\text{mV}/4\text{A} = 0.025\Omega$. This limits R_{S1} power to 0.4W. Let $R_{\text{PROG}} = 5\text{k}$, then:

$$\begin{aligned} R_{S2} = R_{S3} &= \frac{(I_{\text{BAT}})(R_{\text{PROG}})(R_{S1})}{2.465\text{V}} \\ &= \frac{(4\text{A})(5\text{k})(0.025)}{2.465\text{V}} = 200\Omega \end{aligned}$$

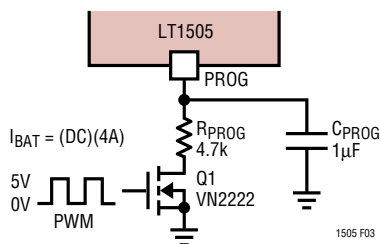

Figure 3. PWM Current Programming

Charge current can also be programmed by pulse width modulating I_{PROG} with a switch Q1 to R_{PROG} at a frequency higher than a few kHz (Figure 3). Charge current will be proportional to the duty cycle of the switch with full current at 100% duty cycle.

When a microprocessor DAC output is used to control charge current, it must be capable of sinking current at a compliance up to 2.5V if connected directly to the PROG pin.

Note that for charge current accuracy and noise immunity, 100mV full scale level across the sense resistor R_{S1} is required. Consequently, both R_{S2} and R_{S3} should be 200Ω .

It is critical to have a good Kelvin connection on the current sense resistor R_{S1} to minimize stray resistive and inductive pickup. R_{S1} should have low parasitic inductance (typical 3nH or less, as exhibited by Dale or IRC sense resistors). The layout path from R_{S2} and R_{S3} to R_{S1} should be kept away from the fast switching SW node. Under low charge current conditions, a low quality sense resistor with high ESL (4nH or higher) coupled with a very noisy current sense path might false trip comparator A12 and turn on BGATE at the wrong time, potentially damaging the bottom power FET. In this case, an RC filter of 10Ω and 10nF should be used across R_{S1} to filter out the noise (see Figure 4).

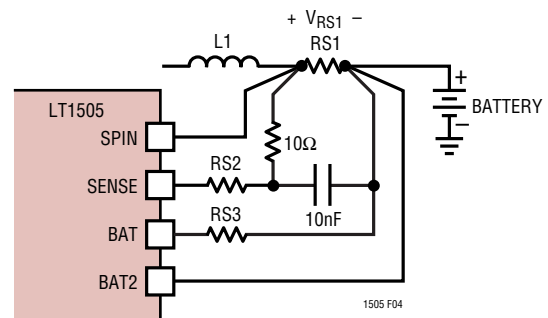

Figure 4. Reducing Current Sensing Noise

Lithium-Ion Charging

The 4A Lithium Battery Charger (Figure 1) charges lithium-ion batteries at a constant 4A until battery voltage reaches the preset value. The charger will then automatically go into a constant-voltage mode with current decreasing to near zero over time as the battery reaches full charge.

APPLICATIONS INFORMATION

Preset Battery Voltage Settings

The LT1505 provides four preset battery voltages: 12.3V, 12.6V, 16.4V and 16.8V. See the Pin Functions section for pin setting voltage selection. An internal switch connects the resistor dividers to the battery sense pin, BAT2. When shutting down the LT1505 by removing adaptor power or by pulling the SHDN pin low, the resistor dividers will be disconnected and will not drain the battery. The BAT2 pin should be connected to the battery when any of the preset battery voltages are used.

External Battery Voltage Setting Resistors

When an external divider is used for other battery voltages, BAT2 should be grounded. Pins 4.1V, 4.2V and 3CELL should be left floating. To minimize battery drain when the charger is off, current through the R3/R4 divider (Figure 5) is set at 15μA. The input current to the V_{FB} pin is 3nA and the error can be neglected.

With divider current set at 15μA, $R4 = 2.465/15\mu\text{A} = 162\text{k}$ and,

$$R3 = \frac{(R4)(V_{\text{BAT}} - 2.465)}{2.465} = \frac{162\text{k}(8.4 - 2.465)}{2.465} = 390\text{k}$$

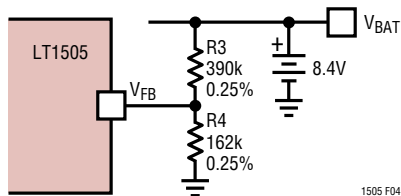

Figure 5. External Resistor Divider

Li-Ion batteries typically require float voltage accuracy of 1% to 2%. Accuracy of the LT1505 V_{FB} voltage is ±0.5% at 25°C and ±1% over the full temperature range. This leads to the possibility that very accurate (0.1%) resistors might be needed for R3 and R4. Actually, the temperature of the LT1505 will rarely exceed 50°C in float mode because charging currents have tapered off to a low level, so 0.25% resistors will normally provide the required level of overall accuracy.

Lithium-Ion Charging Completion

Some battery manufacturers recommend termination of constant-voltage float mode after charge current has dropped below a specified level (typically around 20% of the full current) and a further time-out period of 30 minutes to 90 minutes has elapsed. Check with manufacturers for details. The LT1505 provides a signal at the FLAG pin when charging is in voltage mode and current is reduced to 20% of full current, assuming full charge current is programmed to have 100mV across the current sense resistor (V_{RS1}). The comparator E6 in the Block Diagram compares the charge current sample I_{PROG} to the output current I_{VA} voltage amplifier VA. When the charge current drops to 20% of full current, I_{PROG} will be equal to 0.25 I_{VA} and the open-collector output V_{FLAG} will go low and can be used to start an external timer. When this feature is used, a capacitor of at least 0.1μF is required at the CAP pin to filter out the switching noise and a pull-up resistor is also needed at the FLAG pin. If this feature is not used, C6 is not needed.

Very Low Dropout Operation

The LT1505 can charge the battery even when V_{CC} goes as low as 0.5V above the combined voltages of the battery and the drops on the sense resistor as well as parasitic wiring. This low V_{CC} sometimes requires a duty factor greater than 99% and TGATE stays on for many switching cycles. While TGATE stays on, the voltage V_{BOOST} across the capacitor C2 drops down because TGATE control circuits require 2mA DC current. C2 needs to be recharged before V_{BOOST} drops too low to keep the topside switch on. A unique design allows the LT1505 to operate under these conditions; the comparator A2 monitors V_{BOOST} and when it drops from 9.1V to 6.9V, TGATE will be turned off for about 0.2μs to recharge C2. Note that the LT1505 gets started the same way when power turns on and there is no initial V_{BOOST}.

It is important to use 0.56μF or greater value for C2 to hold V_{BOOST} up for a sufficient amount of time.

When minimum operating V_{CC} is less than 2.5V above the battery voltage, D3 and C4 (see Figure 1) are also needed to bootstrap V_{BOOSTC} higher than V_{CC} to bias the current

APPLICATIONS INFORMATION

amplifier CA1. They are not needed if V_{CC} is at least 2.5V higher than V_{BAT} . The PFET M3 is optional and can be replaced with a diode if V_{IN} is at least 3V higher than V_{BAT} . The gate control pin INFET turns on M3 when V_{IN} gets up above the undervoltage lockout level set by R5 and R6 and is clamped internally to 8V below V_{CC} . In sleep mode when V_{IN} is removed, INFET will clamp M3 V_{SG} to 0.2V.

Shutdown

When adapter power is removed, V_{CC} will drift down and be held by the body diode of the topside NFET switch. As soon as V_{CC} goes down to 0.2V above V_{BAT} , the LT1505 will go into sleep mode drawing only 10 μ A from the battery.

There are two ways to stop switching: pulling the \overline{SHDN} pin low or pulling the V_C pin low. Pulling the \overline{SHDN} pin low will also turn off V_{GBIAS} and CA1 input currents. Pulling the V_C pin low will only stop switching and V_{GBIAS} stays high. Make sure there is a pull-up resistor on the \overline{SHDN} pin even if the \overline{SHDN} pin is not used, otherwise internal pull-down current will keep the \overline{SHDN} pin low and switching off when power turns on.

Each TGATE and BGATE pin has a 50k pull-down resistor to keep the external power FETs off when shut down or power is off.

Note that maximum operating V_{CC} is 24V. For short transients the LT1505 can be operated as high as 27V. For V_{CC} higher than 24V it is preferred to use the V_C pin to shut down. If the \overline{SHDN} pin has to be used to shut down at V_{CC} higher than 24V, the Figure 6 pull-up circuit must be used to slow down the V_{GBIAS} ramp-up rate when the \overline{SHDN} pin is released. Otherwise, high surge current charging the bypass capacitor might damage the LT1505. For V_{CC} less than 24V, only a 100k resistor and no capacitor is needed at \overline{SHDN} pin to V_{IN} for pull-up.

Synchronization

The LT1505 can be synchronized to a frequency range from 240kHz to 280kHz. With a 200ns one-shot timer on chip, the LT1505 provides flexibility on the synchronizing pulse width. Sync pulse threshold is about 1.2V (Figure 7).

Nickel-Cadmium and Nickel-Metal-Hydride Charging

The circuit in the 4A Lithium Battery Charger (Figure 1) can be modified to charge NiCd or NiMH batteries. For example, 2-level charging is needed; 2A when Q1 is on, and 200mA when Q1 is off (Figure 8).

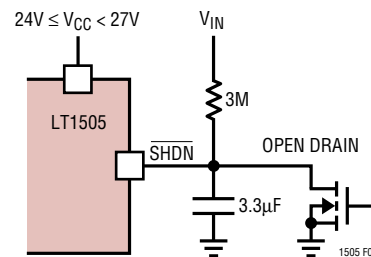

Figure 6. High Input Voltage Shutdown

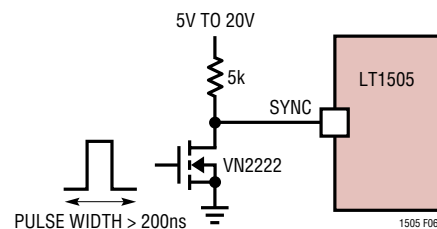

Figure 7. Synchronizing with External Clock

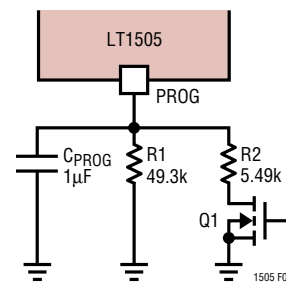

Figure 8. 2-Level Charging

For 2A full current, the current sense resistor (R_{S1}) should be increased to 0.05 Ω so that enough signal (10mV) will be across R_{S1} at 0.2A trickle charge to keep charging current accurate.

For a 2-level charger, R1 and R2 are found from:

$$R1 = \frac{(2.465)(4000)}{I_{LOW}} \quad R2 = \frac{(2.465)(4000)}{I_{HI} - I_{LOW}}$$

APPLICATIONS INFORMATION

All battery chargers with fast charge rates require some means to detect full charge state in the battery to terminate the high charge current. NiCd batteries are typically charged at high current until temperature rise or battery voltage decrease is detected as an indication of near full charge. The charge current is then reduced to a much lower value and maintained as a constant trickle charge. An intermediate “top off” current may be used for a fixed time period to reduce 100% charge time.

NiMH batteries are similar in chemistry to NiCd but have two differences related to charging. First, the inflection characteristic in battery voltage as full charge is approached is not nearly as pronounced. This makes it more difficult to use $-\Delta V$ as an indicator of full charge, and an increase in temperature is more often used with a temperature sensor in the battery pack. Secondly, constant trickle charge may not be recommended. Instead, a moderate level of current is used on a pulse basis ($\approx 1\%$ to 5% duty cycle) with the time-averaged value substituting for a constant low trickle. Please contact the Linear Technology Applications department about charge termination circuits.

If overvoltage protection is needed, R3 and R4 in Figure 5 should be calculated according to the procedure described in the Lithium-Ion Charging section. The V_{FB} pin should be grounded if not used.

Charger Crowbar Protection

If the V_{IN} connector of Figure 1 can be instantaneously shorted (crowbarred) to ground, then a small P-channel FET M4 should be used to quickly turn off the input P-channel FET M3 (see Figure 9), otherwise, high reverse surge current might damage M3. M3 can also be replaced by a diode if dropout voltage and heat dissipation are not problems.

Note that the LT1505 will operate even when V_{BAT} is grounded. If V_{BAT} of Figure 1 charger gets shorted to ground very quickly (crowbarred) from a high battery voltage, slow loop response may allow charge current to build up and damage the topside N-channel FET M1. A small diode D5 (see Figure 10) from the SHDN pin to V_{BAT} will shut down switching and protect the charger.

Note that M4 and/or D5 are needed only if the charger system can be potentially crowbarred.

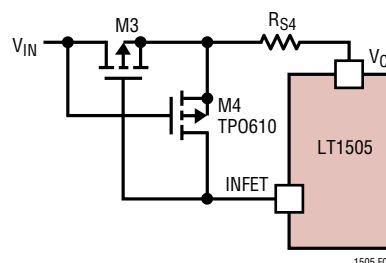

Figure 9. V_{IN} Crowbar Protection

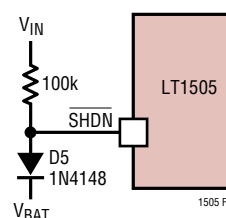

Figure 10. V_{BAT} Crowbar Protection

Layout Considerations

Switch rise and fall times are under 20ns for maximum efficiency. To prevent radiation, the power MOSFETs, the SW pin and input bypass capacitor leads should be kept as short as possible. A Schottky diode (D4 in Figure 1) rated for at least 1A is necessary to clamp the SW pin and should be placed close to the low side MOSFET. A ground plane should be used under the switching circuitry to prevent interplane coupling and to act as a thermal spreading path. Note that the inductor is probably the most heat dissipating device in the charging system. The resistance on a 4A, $15\mu\text{H}$ inductor, can be 0.03Ω . With DC and AC losses, the power dissipation can go as high as 0.8W. Expanded traces should be used for the inductor leads for low thermal resistance.

The fast switching high current ground path including the MOSFETs, D4 and input bypass capacitor should be kept very short. Another smaller input bypass ($1\mu\text{F}$ ceramic) should be placed very close to the chip. The demo board DC219 should be used for layout reference.

PACKAGE DESCRIPTION

G Package
28-Lead Plastic SSOP (5.3mm)
 (Reference LTC DWG # 05-08-1640)

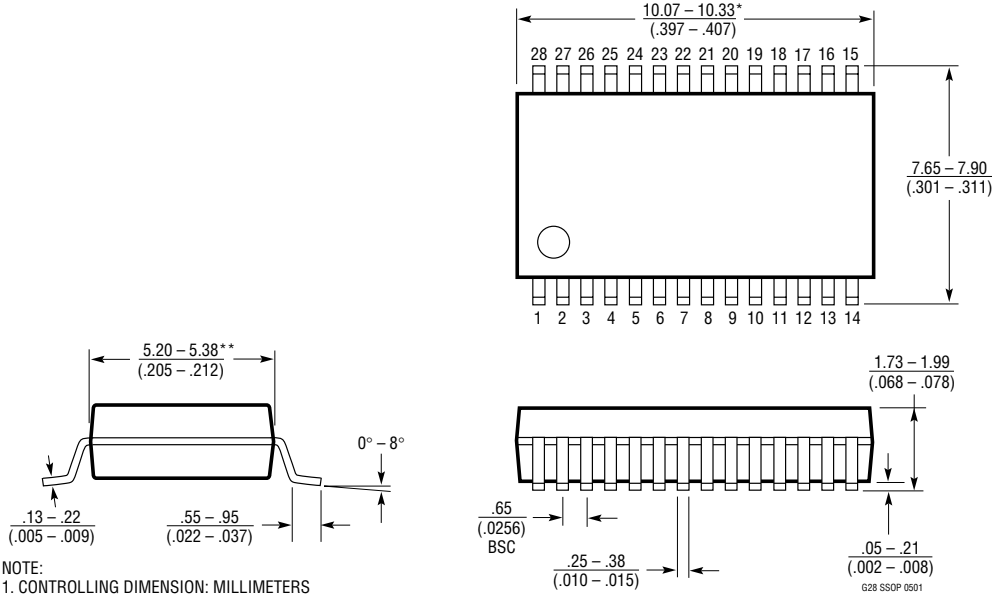

NOTE:
 1. CONTROLLING DIMENSION: MILLIMETERS
 2. DIMENSIONS ARE IN MILLIMETERS (INCHES)
 3. DRAWING NOT TO SCALE
 *DIMENSIONS DO NOT INCLUDE MOLD FLASH. MOLD FLASH SHALL NOT EXCEED .152mm (.006") PER SIDE
 **DIMENSIONS DO NOT INCLUDE INTERLEAD FLASH. INTERLEAD FLASH SHALL NOT EXCEED .254mm (.010") PER SIDE

RELATED PARTS

PART NUMBER	DESCRIPTION	COMMENTS
LT1372/LT1377	1.5A, 500kHz/1MHz Step-Up Switching Regulators	High Frequency, Small Inductor, High Efficiency Switchers, SO-8
LT1376	1.5A, 500kHz Step-Down Switching Regulator	High Frequency, Small Inductor, High Efficiency Switcher, SO-8
LT1510	Constant-Voltage/Constant-Current Battery Charger	Up to 1.5A Charge Current, Small SO-8 Footprint
LT1511	3A Constant-Voltage/Constant-Current Battery Charger	Charges Lithium, NiCd and NiMH Batteries, 28-Lead SO Package
LT1512	SEPIC CC/CV Battery Charger	V _{IN} Can Be Higher or Lower Than Battery Voltage, 2A Internal Switch
LT1513	SEPIC CC/CV Battery Charger	V _{IN} Can Be Higher or Lower Than Battery Voltage, 3A Internal Switch
LT1571	Constant-Voltage/Constant-Current Battery Charger	1.5A Charge Current, Preset Voltage for 1 or 2 Li-Ion Cells, C/10 Flag
LTC1731	Linear Charger Controller	Programmable Timer; 8-Pin MSOP; C/10 Flag
LTC1732	Linear Charger Controller	AC Adapter Present Flag; Programmable Timer; 10-Pin MSOP; C/10 Flag
LTC1733	Linear Charger with Integrated FET	1.5A Charge Current, Programmable Timer, 10-Pin Thermally Enhanced MSOP Package
LTC1734	Linear Charger Controller	Inexpensive Constant-Voltage/Constant-Current Li-Ion Charger, 5-Pin SOT-23 Package
LTC1759	SMBus Controlled Smart Battery Charger	LT1505 Charger Functionality with SMBus Control
LT1769	2A Constant-Voltage/Constant-Current Battery Charger	Charges Lithium, NiCd and NiMH Batteries, 20-Lead Exposed Pad TSSOP
LTC1960	Dual Battery Charger and Selector with SPI Interface	I _{CHARGE} up to 6A, Fast Charge, Longer Battery Life, Crisis Management

X-ON Electronics

Largest Supplier of Electrical and Electronic Components

Click to view similar products for [Battery Management](#) category:

Click to view products by [Analog Devices](#) manufacturer:

Other Similar products are found below :

[MP26121DQ-LF-P](#) [NCP1855FCCT1G](#) [FAN54063UCX](#) [LC05132C01NMTTTG](#) [SN2040DSQR](#) [ME4075AM5G](#) [AP5054HTCER](#) [TC2120-NB](#) [XPD977B](#) [XPD977B18](#) [4056H](#) [DW01](#) [DW06](#) [CM1002-UD](#) [CM1002-W](#) [CM1002-X](#) [CM1002-Y](#) [CM1006-B](#) [CM1006-Q](#) [CM1006-WB](#) [CM1006-LCD](#) [CM1006-LBD](#) [CM1006-WF](#) [CM1006-LF](#) [CM1006-WG](#) [CM1006-WH](#) [CM1006-LG](#) [CM1003-S02BD](#) [CM1003-S09EA](#) [CM1003-S10ED](#) [CM1003-S11ED](#) [CM1003-S12BC](#) [CM1003-S13CC](#) [CM1003-S24BC](#) [CM1003-S26BC](#) [CM1003-WAD](#) [CM1003-BBD](#) [CM1003-BFD](#) [CM1003-BND](#) [CM1003-BLD](#) [CM1003-DAD](#) [CM1003-BMD](#) [CM1003-BPD](#) [CM1003-BKD](#) [CM1003-BAE](#) [CM1003-BHE](#) [CM1102B-FF](#) [CM1102B-FD](#) [CM1102B-GD](#) [CM1112-DAE](#)