

FEATURES

- **1A, 0.5Ω, 30V Internal Switch**
- Operates with V_{IN} as Low as 1.5V
- 600kHz Fixed Frequency Operation
- Low-Battery Detector Stays Active in Shutdown
- Low V_{CESAT} Switch: 410mV at 800mA
- Pin-for-Pin Compatible with the LT1317B
- Small 8-Lead MSOP and SO Packages

APPLICATIONS

- LCD Bias Supplies
- GPS Receivers
- Battery Backup
- Portable Electronic Equipment
- Diagnostic Medical Instrumentation

DESCRIPTION

The LT[®]1949 is a fixed frequency step-up DC/DC converter with a 1A, 0.5Ω internal switch. Capable of generating 10V at 175mA from a 3.3V input, the LT1949 is ideal for generating bias voltages for large screen LCD panels. Constant frequency 600kHz operation results in a low noise output that is easy to filter and the 30V switch rating allows output voltage up to 28V using a single inductor. An external compensation pin gives the user flexibility in optimizing loop compensation, allowing small low ESR ceramic capacitors to be used at the output. The 8-lead MSOP and SO packages ensure a low profile overall solution.

The LT1949 includes a low-battery detector that stays alive when the device goes into shutdown. Quiescent current in shutdown is 25μA, while operating current is 4.5mA.

 LTC and LT are registered trademarks of Linear Technology Corporation.

TYPICAL APPLICATION

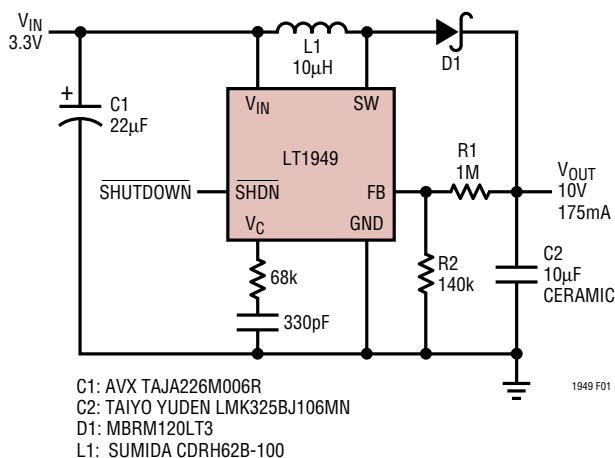

Figure 1. 3.3V to 10V/175mA DC/DC Converter

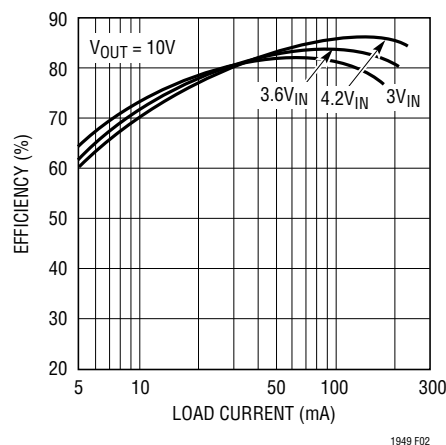
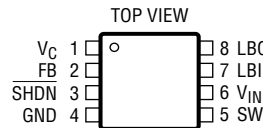
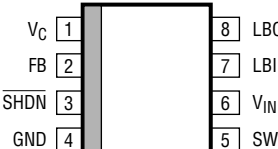

Figure 2. 3.3V to 10V Converter Efficiency

ABSOLUTE MAXIMUM RATINGS (Note 1)

V_{IN} , LBO Voltage	12V	Junction Temperature	125°C
SW Voltage	-0.4V to 30V	Operating Temperature Range (Note 2)	
FB Voltage	$V_{IN} + 0.3V$	LT1949EMS8	-40°C to 85°C
V_C Voltage	2V	LT1949ES8/LT1949IS8	-40°C to 85°C
LBI Voltage	$0V \leq V_{LBI} \leq 1V$	Storage Temperature	-65°C to 150°C
SHDN Voltage	6V	Lead Temperature (Soldering, 10sec)	300°C

PACKAGE/ORDER INFORMATION

 <p>MS8 PACKAGE 8-LEAD PLASTIC MSOP $T_{JMAX} = 125^{\circ}C, \theta_{JA} = 120^{\circ}C/W$</p>	ORDER PART NUMBER	 <p>S8 PACKAGE 8-LEAD PLASTIC SO $T_{JMAX} = 125^{\circ}C, \theta_{JA} = 120^{\circ}C/W$</p>	ORDER PART NUMBER
	LT1949EMS8		LT1949ES8 LT1949IS8
	MS8 PART MARKING		S8 PART MARKING
	LTJC		1949E 1949I

Consult factory for Military grade parts.

ELECTRICAL CHARACTERISTICS The ● denotes specifications which apply over the full operating temperature range, otherwise specifications are $T_A = 25^{\circ}C$. $V_{IN} = 2V$, $V_{SHDN} = 2V$ unless otherwise noted.

SYMBOL	PARAMETER	CONDITIONS	MIN	TYP	MAX	UNITS	
I_Q	Quiescent Current	$V_{SHDN} = 0V$	●	4.5	7.5	mA	
			●	25	40	μA	
V_{FB}	Feedback Voltage		●	1.22	1.24	1.26	V
			●	1.20	1.24	1.26	V
I_B	FB Pin Bias Current (Note 3)		●	12	80	nA	
	Input Voltage Range		●	1.7	12	V	
g_m	Error Amp Transconductance	$\Delta I = 5\mu A$	●	70	140	240	$\mu mhos$
A_V	Error Amp Voltage Gain			700		V/V	
	Maximum Duty Cycle		●	80	85	%	
	Switch Current Limit (Note 4)	$V_{IN} = 2.5V, Duty Cycle = 30\%$	●	1	1.13	1.5	A
		$V_{IN} = 2.5V, Duty Cycle = 30\%$	●	0.95		1.5	A
f_{OSC}	Switching Frequency		●	500	600	750	kHz
	Shutdown Pin Current	$V_{SHDN} = V_{IN}$ $V_{SHDN} = 0V$	●	0.015	0.1	μA	
●			-2.3	-7	μA		
	LBI Threshold Voltage		●	190	200	210	mV
			●	180	200	220	mV
	LBO Output Low	$I_{SINK} = 10\mu A$	●	0.15	0.25	V	
	LBO Leakage Current	$V_{LBI} = 250mV, V_{LBO} = 5V$	●	0.02	0.1	μA	
	LBI Input Bias Current (Note 5)	$V_{LBI} = 150mV$	●	5	60	nA	
	Low-Battery Detector Gain	1M Ω Pull-Up		2000		V/V	
	Switch Leakage Current	$V_{SW} = 5V$	●	0.01	3	μA	

ELECTRICAL CHARACTERISTICS

The ● denotes specifications which apply over the full operating temperature range, otherwise specifications are $T_A = 25^\circ\text{C}$. $V_{IN} = 2\text{V}$, $V_{SHDN} = 2\text{V}$ unless otherwise noted.

SYMBOL	PARAMETER	CONDITIONS	MIN	TYP	MAX	UNITS
	Switch V_{CESAT}	$I_{SW} = 800\text{mA}$ $I_{SW} = 500\text{mA}$	●	410	400	mV
	Reference Line Regulation	$1.8\text{V} \leq V_{IN} \leq 12\text{V}$	●	0.08	0.15	%/V
	$\overline{\text{SHDN}}$ Input Voltage High		●	1.4	6	V
	$\overline{\text{SHDN}}$ Input Voltage Low		●		0.4	V

Note 1: Absolute Maximum Ratings are those values beyond which the life of a device may be impaired.

Note 2: The LT1949E is guaranteed to meet performance specifications from 0°C to 70°C . Specifications over the -40°C to 85°C operating temperature range are assured by design, characterization and correlation with statistical process controls.

Note 3: Bias current flows into FB pin.

Note 4: Switch current limit guaranteed by design and/or correlation to static tests. Duty cycle affects current limit due to ramp generator.

Note 5: Bias current flows out of LBI pin.

TYPICAL PERFORMANCE CHARACTERISTICS

Oscillator Frequency

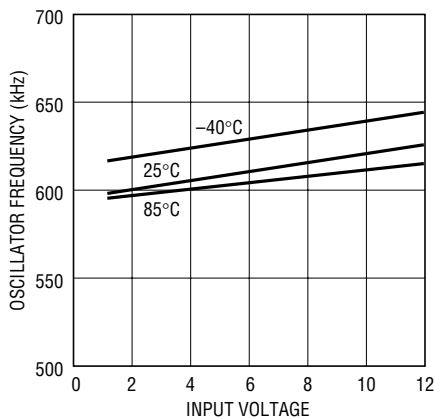

1949 G01

Switch Current Limit

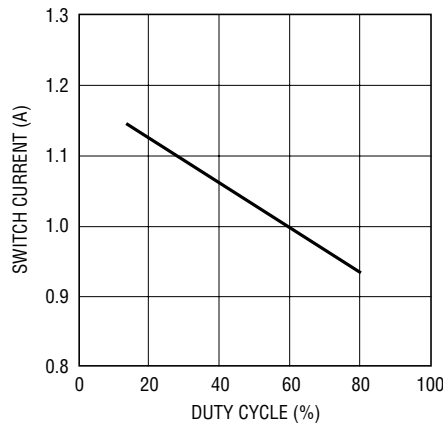

1949 G02

Switch Current Limit, Duty Cycle = 30%

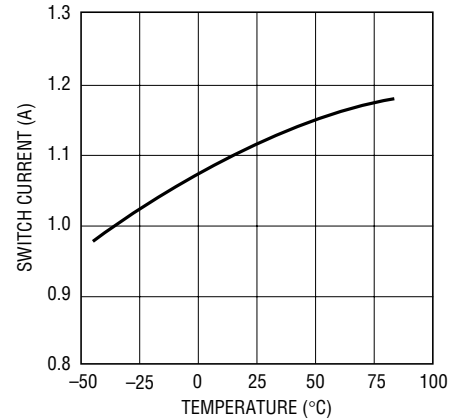

1949 G03

Switch Voltage Drop (V_{CESAT})

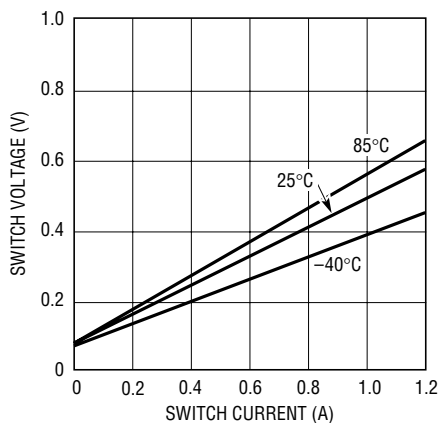

1949 G04

Feedback Voltage

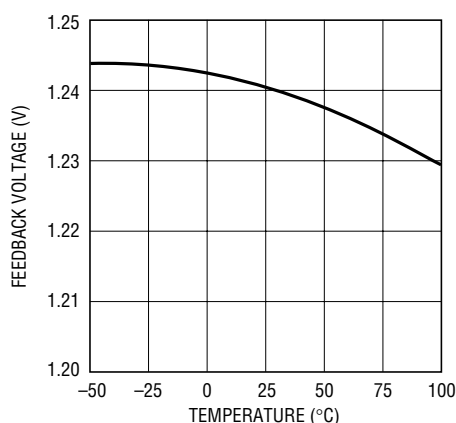

1949 G05

Quiescent Current, $\overline{\text{SHDN}} = 2\text{V}$

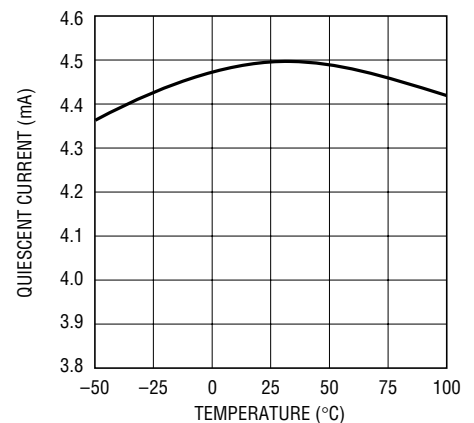

1949 G06

TYPICAL PERFORMANCE CHARACTERISTICS

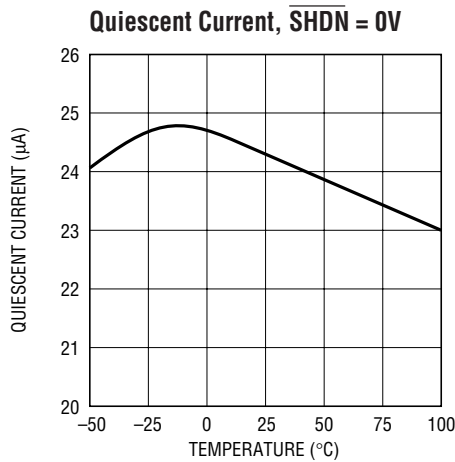

1317 TPC10

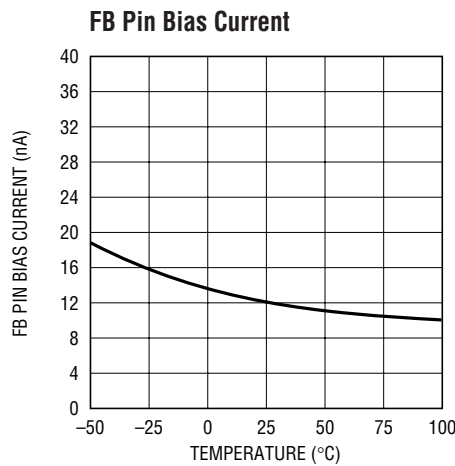

1317 TPC11

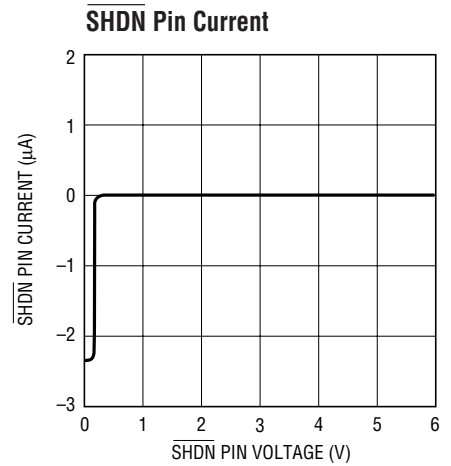

1317 TPC12

Load Regulation

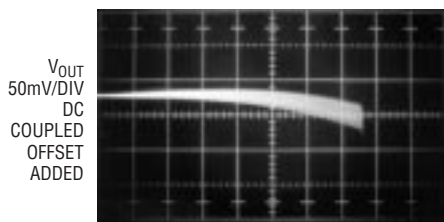

$V_{IN} = 3\text{V}$
 $V_{OUT} = 10\text{V}$
 $L1 = 10\mu\text{H}$, SUMIDA CD54
 $C_{OUT} = 10\mu\text{F}$ CERAMIC

1949 G10

Load Regulation

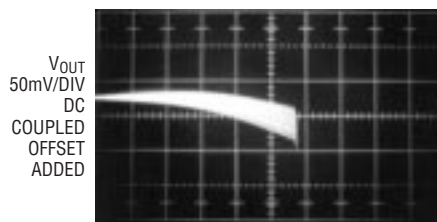

$V_{IN} = 4\text{V}$
 $V_{OUT} = 10\text{V}$
 $L1 = 10\mu\text{H}$, SUMIDA CD54
 $C_{OUT} = 10\mu\text{F}$ CERAMIC

1949 G11

Transient Response

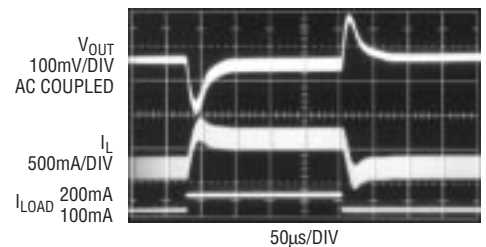

$V_{IN} = 3.3\text{V}$
 $V_{OUT} = 10\text{V}$
 CIRCUIT OF FIGURE 1

1949 G12

PIN FUNCTIONS

V_C (Pin 1): Compensation Pin for Error Amplifier. Connect a series RC network from this pin to ground. Typical values for compensation are a 68k/330pF combination when using ceramic output capacitors. Minimize trace area at V_C .

FB (Pin 2): Feedback Pin. Reference voltage is 1.24V. Connect resistor divider tap here. Minimize trace area at FB. Set V_{OUT} according to: $V_{OUT} = 1.24\text{V}(1 + R1/R2)$.

$\overline{\text{SHDN}}$ (Pin 3): Shutdown. Pull this pin low for shutdown mode (only the low-battery detector remains active). Leave this pin floating or tie to a voltage between 1.4V and 6V to enable the device. $\overline{\text{SHDN}}$ pin is logic level and need only meet the logic specification (1.4V for high, 0.4V for low).

GND (Pin 4): Ground. Connect directly to local ground plane.

SW (Pin 5): Switch Pin. Connect inductor/diode here. Minimize trace area at this pin to keep EMI down.

V_{IN} (Pin 6): Supply Pin. Must be bypassed close to the pin.

LBI (Pin 7): Low-Battery Detector Input. 200mV reference. Voltage on LBI must stay between ground and 700mV. Low-battery detector remains active in shutdown mode.

LBO (Pin 8): Low-Battery Detector Output. Open collector, can sink 10µA. A 1MΩ pull-up is recommended.

BLOCK DIAGRAM

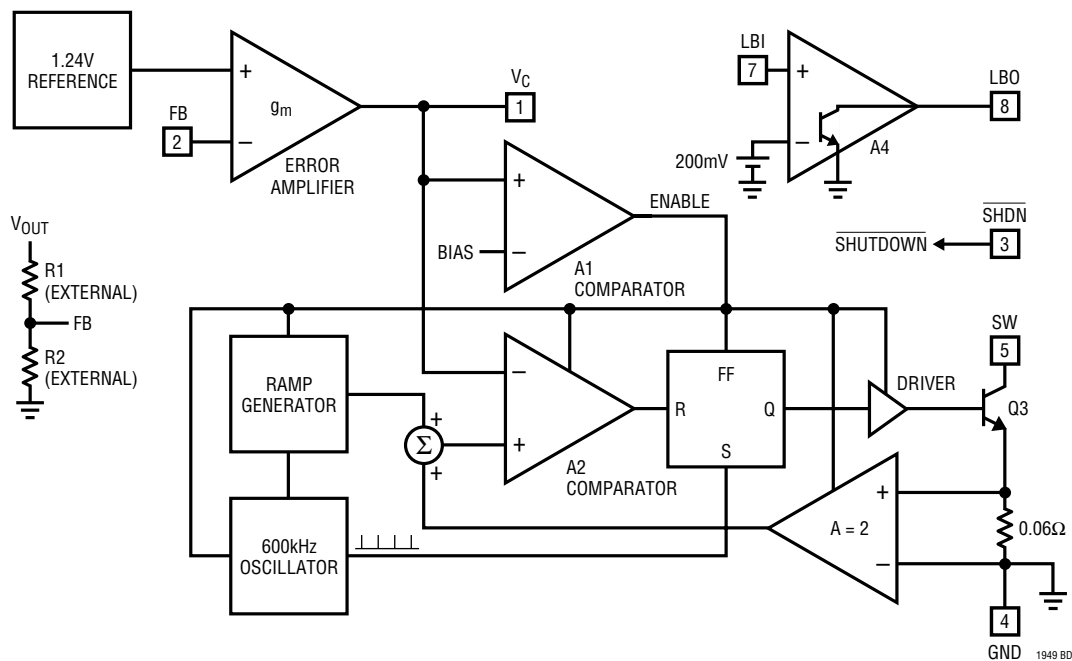

Figure 3. LT1949 Block Diagram

OPERATION

The LT1949 is a current mode, fixed frequency step-up DC/DC converter with an internal 1A NPN power transistor. Operation can best be understood by referring to the Block Diagram.

At the beginning of each oscillator cycle, the flip-flop is set and the switch is turned on. Current in the switch ramps up until the voltage at A2's positive input reaches the V_C pin voltage, causing A2's output to change state and the switch to be turned off. The signal at A2's positive input is a summation of a signal representing switch current and a ramp generator (introduced to avoid subharmonic oscillations at duty factors greater than 50%). If the load increases, V_{OUT} (and FB) will drop slightly and the error amplifier will drive V_C to a higher voltage, causing current in the switch to increase. In this way, the error amplifier drives the V_C pin to the voltage necessary to satisfy the load. Frequency compensation is provided by an external series RC network connected between the V_C pin and ground.

Layout Hints

The LT1949 switches current at high speed, mandating careful attention to layout for proper performance. *You will not get advertised performance with careless layouts.* Figure 4 shows recommended component placement for a boost (step-up) converter. Follow this closely in your PC layout. Note the direct path of the switching loops. Input capacitor C1 *must* be placed close (<5mm) to the IC package. As little as 10mm of wire or PC trace from C_{IN} to V_{IN} will cause problems such as inability to regulate or oscillation.

The ground terminal of output capacitor C2 should tie close to Pin 4 of the LT1949. Doing this reduces di/dt in the ground copper which keeps high frequency spikes to a minimum. The DC/DC converter ground should tie to the PC board ground plane at one place only, to avoid introducing di/dt in the ground plane.

OPERATION

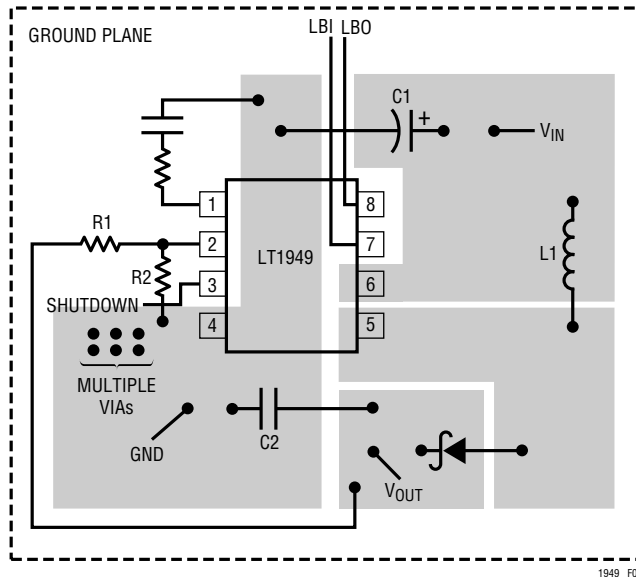

Figure 4. Recommended Component Placement for Boost Converter. Note Direct High Current Paths Using Wide PC Traces. Minimize Trace Area at Pin 1 (V_C) and Pin 2 (FB). Use Multiple Vias to Tie Pin 4 Copper to Ground Plane. Use Vias at One Location Only to Avoid Introducing Switching Currents into the Ground Plane

APPLICATIONS INFORMATION

Low-Battery Detector

The LT1949's low-battery detector is a simple PNP input gain stage with an open collector NPN output. The negative input of the gain stage is tied internally to a 200mV ±5% reference. The positive input is the LBI pin. Arrangement as a low-battery detector is straightforward.

Figure 5 details hookup. R1 and R2 need only be low enough in value so that the bias current of the LBI pin doesn't cause large errors. For R2, 100k is adequate. The 200mV reference can also be accessed as shown in Figure 6. The low-battery detector remains active in shutdown.

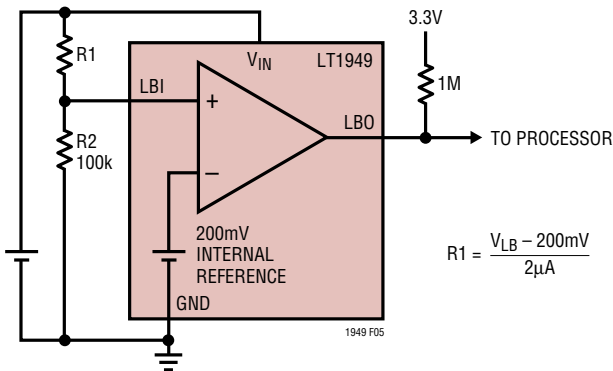

Figure 5. Setting Low-Battery Detector Trip Point

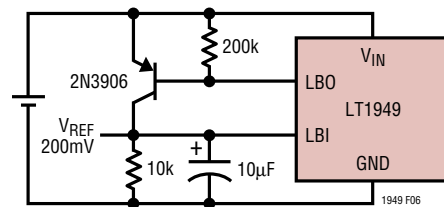
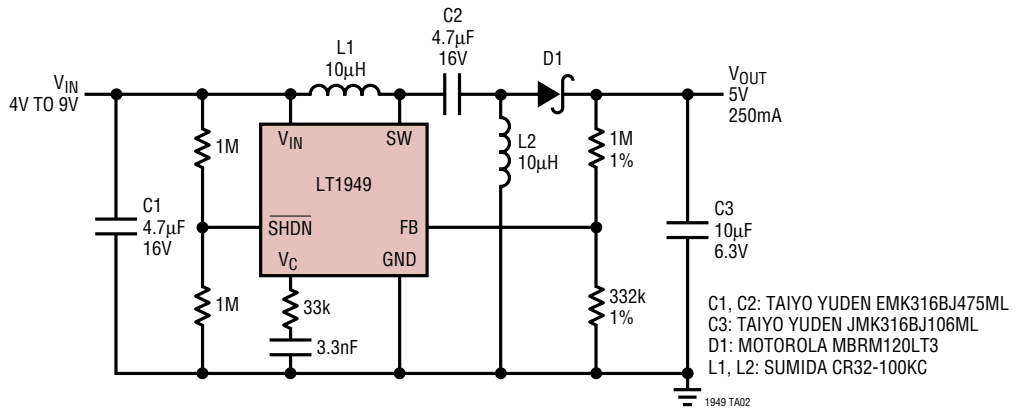

Figure 6. Accessing 200mV Reference

TYPICAL APPLICATION

4 Cell to 5V SEPIC Converter



PACKAGE DESCRIPTION

Dimensions in inches (millimeters) unless otherwise noted.

MS8 Package
8-Lead Plastic MSOP
 (LTC DWG # 05-08-1660)

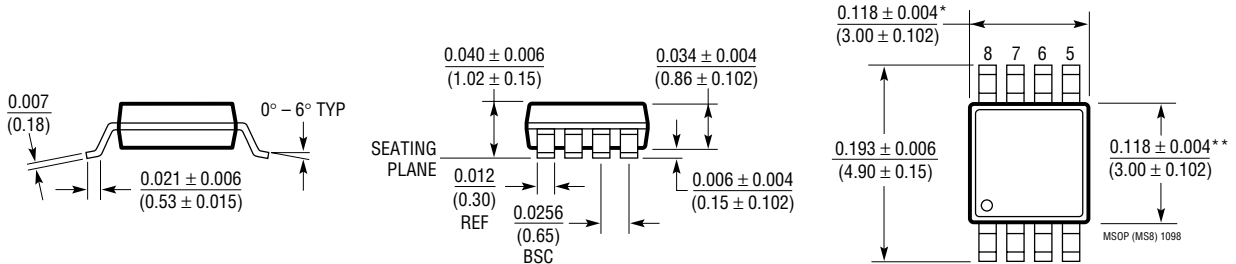

* DIMENSION DOES NOT INCLUDE MOLD FLASH, PROTRUSIONS OR GATE BURRS. MOLD FLASH, PROTRUSIONS OR GATE BURRS SHALL NOT EXCEED 0.006* (0.152mm) PER SIDE

** DIMENSION DOES NOT INCLUDE INTERLEAD FLASH OR PROTRUSIONS. INTERLEAD FLASH OR PROTRUSIONS SHALL NOT EXCEED 0.006* (0.152mm) PER SIDE

S8 Package
8-Lead Plastic Small Outline (Narrow 0.150)
 (LTC DWG # 05-08-1610)

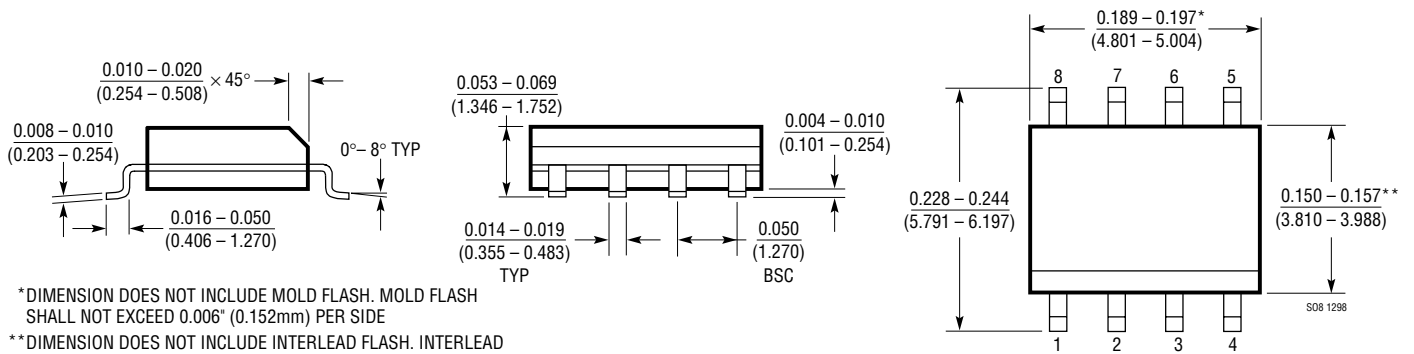

DIMENSION DOES NOT INCLUDE MOLD FLASH. MOLD FLASH SHALL NOT EXCEED 0.006 (0.152mm) PER SIDE

**DIMENSION DOES NOT INCLUDE INTERLEAD FLASH. INTERLEAD FLASH SHALL NOT EXCEED 0.010* (0.254mm) PER SIDE

TYPICAL APPLICATION

Low Profile Triple Output LCD Bias Generator

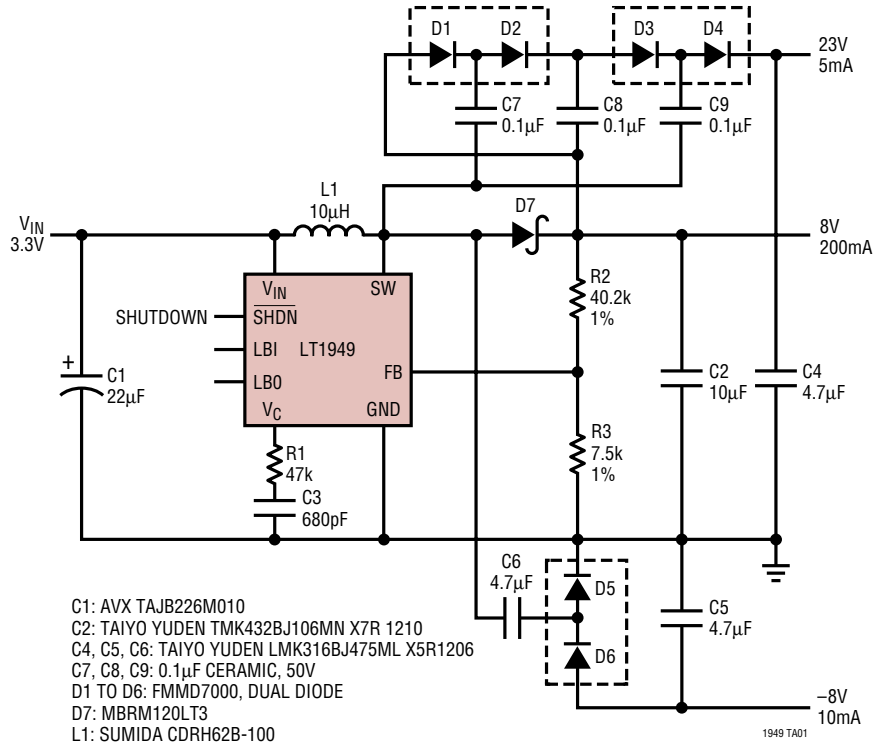

RELATED PARTS

PART NUMBER	DESCRIPTION	COMMENTS
LT1054	High Power Regulated Charge Pump	Up to 100mA Output with No Inductors
LT1302	High Output Current Micropower DC/DC Converter	5V/600mA from 2V, 2A Internal Switch, 200µA I _Q
LT1304	2-Cell Micropower DC/DC Converter	Low-Battery Detector Active in Shutdown
LT1307B	Single Cell Micropower 600kHz PWM DC/DC Converter	3.3V at 75mA from 1 Cell, MSOP Package
LT1308B	2A 600kHz PWM DC/DC Converter	TSSOP Package
LT1317B	Micropower, 600kHz PWM DC/DC Converter	2 Cells to 3.3V at 200mA, MSOP Package
LTC [®] 1516	2-Cell to 5V Regulated Charge Pump	12µA I _Q , No Inductors, 5V at 50mA from 3V Input
LT1613	Single Cell 1.4MHz PWM DC/DC Converter	3.3V to 5V at 200mA, SOT-23 Package
LTC1682	Doubler Charge Pump with Low Noise Linear Regulator	3.3V and 5V Outputs with 60µV _{RMS} Noise, Up to 80mA Output
LTC1754	Micropower 3.3V/5V Charge Pump with Shutdown	Up to 50mA Output, I _Q = 13µA, SOT-23 Package

X-ON Electronics

Largest Supplier of Electrical and Electronic Components

Click to view similar products for [Switching Voltage Regulators](#) category:

Click to view products by [Analog Devices](#) manufacturer:

Other Similar products are found below :

[FAN53610AUC33X](#) [FAN53611AUC123X](#) [FAN48610BUC33X](#) [FAN48610BUC45X](#) [FAN48617UC50X](#) [R3](#) [430464BB](#) [KE177614](#)
[MAX809TTR](#) [NCV891234MW50R2G](#) [NCP81103MNTXG](#) [NCP81203PMNTXG](#) [NCP81208MNTXG](#) [NCP81109GMNTXG](#)
[SCY1751FCCT1G](#) [NCP81109JMNTXG](#) [AP3409ADNTR-G1](#) [NCP81241MNTXG](#) [LTM8064IY](#) [LT8315EFE#TRPBF](#) [LTM4664EY#PBF](#)
[LTM4668AIY#PBF](#) [NCV1077CSTBT3G](#) [XCL207A123CR-G](#) [MPM54304GMN-0002](#) [MPM54304GMN-0004](#) [MPM54304GMN-0003](#)
[AP62300Z6-7](#) [MP8757GL-P](#) [MIC23356YFT-TR](#) [LD8116CGL](#) [HG2269M/TR](#) [OB2269](#) [XD3526](#) [U6215A](#) [U6215B](#) [U6620S](#) [LTC3412IFE](#)
[LT1425IS](#) [MAX25203BATJA/VY+](#) [MAX77874CEWM+](#) [XC9236D08CER-G](#) [MP3416GJ-P](#) [BD9S201NUX-CE2](#) [MP5461GC-Z](#)
[MPQ4415AGQB-Z](#) [MPQ4590GS-Z](#) [MAX38640BENT18+T](#) [MAX77511AEWB+](#) [MAX20406AFOD/VY+](#)