

# 36V, 2A, 2.8MHz Step-Down Switching Regulator with 50µA Quiescent Current

## FEATURES

- **Wide Input Range: 3.6V to 34V Operating, 36V Maximum**
- **2A Maximum Output Current**
- **Low Ripple Burst Mode® Operation**  
 50µA  $I_Q$  at 12V<sub>IN</sub> to 3.3V<sub>OUT</sub>  
 Output Ripple < 15mV
- **Adjustable Switching Frequency: 300kHz to 2.8MHz**
- **Low Shutdown Current:  $I_Q < 1\mu A$**
- **Integrated Boost Diode**
- Power Good Flag
- Saturating Switch Design: 0.18Ω On-Resistance
- 1.265V Feedback Reference Voltage
- Output Voltage: 1.265V to 20V
- Soft-Start Capability
- Synchronizable Between 275kHz to 475kHz
- Small 10-Pin Thermally Enhanced MSOP and (3mm x 3mm) DFN Packages

## APPLICATIONS

- Automotive Battery Regulation
- Power for Portable Products
- Distributed Supply Regulation
- Industrial Supplies
- Wall Transformer Regulation

## DESCRIPTION

The LT®3481 is an adjustable frequency (300kHz to 2.8MHz) monolithic buck switching regulator that accepts input voltages up to 34V (36V maximum). A high efficiency 0.18Ω switch is included on the die along with a boost Schottky diode and the necessary oscillator, control, and logic circuitry. Current mode topology is used for fast transient response and good loop stability. Low ripple Burst Mode operation maintains high efficiency at low output currents while keeping output ripple below 15mV in a typical application. In addition, the LT3481 can further enhance low output current efficiency by drawing bias current from the output when V<sub>OUT</sub> is above 3V. Shutdown reduces input supply current to less than 1µA while a resistor and capacitor on the RUN/SS pin provide a controlled output voltage ramp (soft-start). A power good flag signals when V<sub>OUT</sub> reaches 90% of the programmed output voltage. The LT3481 is available in 10-Pin MSOP and 3mm x 3mm DFN packages with exposed pads for low thermal resistance.

LT, LT, LTC, LTM, Burst Mode, Linear Technology and the Linear logo are registered trademarks of Linear Technology Corporation. All other trademarks are the property of their respective owners.

## TYPICAL APPLICATION

3.3V Step-Down Converter

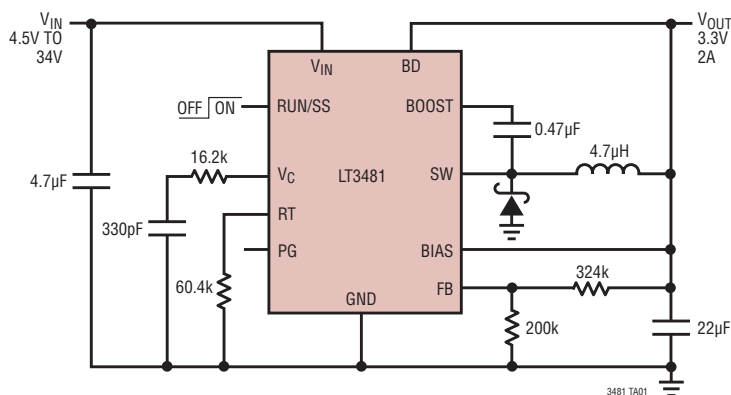

Efficiency

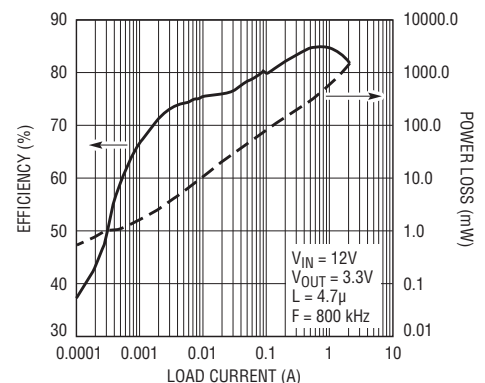

# LT3481

## ABSOLUTE MAXIMUM RATINGS (Note 1)

$V_{IN}$ , RUN/SS Voltage.....	36V
BOOST Pin Voltage.....	56V
BOOST Pin Above SW Pin.....	30V
FB, RT, $V_C$ Voltage.....	5V
BIAS, PG, BD Voltage.....	30V
Maximum Junction Temperature.....	125°C
LT3481E, LT3481I.....	125°C
LT3481H.....	150°C

Operating Temperature Range (Note 2)	
LT3481E.....	-40°C to 85°C
LT3481I.....	-40°C to 125°C
LT3481H.....	-40°C to 150°C
Storage Temperature Range.....	-65°C to 150°C
Lead Temperature (Soldering, 10 sec)	
MSE Only.....	300°C

## PIN CONFIGURATION



## ORDER INFORMATION

LEAD FREE FINISH	TAPE AND REEL	PART MARKING*	PACKAGE DESCRIPTION	TEMPERATURE RANGE
LT3481EDD#PBF	LT3481EDD#TRPBF	LBVS	10-Lead (3mm × 3mm) Plastic DFN	-40°C to 85°C
LT3481IDD#PBF	LT3481IDD#TRPBF	LBVV	10-Lead (3mm × 3mm) Plastic DFN	-40°C to 125°C
LT3481HDD#PBF	LT3481HDD#TRPBF	LBVS	10-Lead (3mm × 3mm) Plastic DFN	-40°C to 150°C
LT3481EMSE#PBF	LT3481EMSE#TRPBF	LTBVT	10-Lead Plastic MSOP	-40°C to 85°C
LT3481IMSE#PBF	LT3481IMSE#TRPBF	LTBVW	10-Lead Plastic MSOP	-40°C to 125°C
LT3481HMSE#PBF	LT3481HMSE#TRPBF	LTBVT	10-Lead Plastic MSOP	-40°C to 150°C
LEAD BASED FINISH	TAPE AND REEL	PART MARKING*	PACKAGE DESCRIPTION	TEMPERATURE RANGE
LT3481EDD	LT3481EDD#TR	LBVS	10-Lead (3mm × 3mm) Plastic DFN	-40°C to 85°C
LT3481IDD	LT3481IDD#TR	LBVV	10-Lead (3mm × 3mm) Plastic DFN	-40°C to 125°C
LT3481HDD	LT3481HDD#TR	LBVS	10-Lead (3mm × 3mm) Plastic DFN	-40°C to 150°C
LT3481EMSE	LT3481EMSE#TR	LTBVT	10-Lead Plastic MSOP	-40°C to 85°C
LT3481IMSE	LT3481IMSE#TR	LTBVW	10-Lead Plastic MSOP	-40°C to 125°C
LT3481HMSE	LT3481HMSE#TR	LTBVT	10-Lead Plastic MSOP	-40°C to 150°C

Consult LTC Marketing for parts specified with wider operating temperature ranges. \*The temperature grade is identified by a label on the shipping container.

For more information on lead free part marking, go to: <http://www.linear.com/leadfree/>

For more information on tape and reel specifications, go to: <http://www.linear.com/tapeandreeel/>

**ELECTRICAL CHARACTERISTICS** The ● denotes the specifications which apply over the full operating temperature range, otherwise specifications are at  $T_A = 25^\circ\text{C}$ .  $V_{IN} = 10\text{V}$ ,  $V_{RUN/SS} = 10\text{V}$ ,  $V_{BOOST} = 15\text{V}$ ,  $V_{BIAS} = 3.3\text{V}$  unless otherwise noted. (Note 2)

PARAMETER	CONDITIONS		MIN	TYP	MAX	UNITS
Minimum Input Voltage		●		3	3.6	V
Quiescent Current from $V_{IN}$	$V_{RUN/SS} = 0.2\text{V}$			0.01	0.5	$\mu\text{A}$
	$V_{BIAS} = 3\text{V}$ , Not Switching	●		22	60	$\mu\text{A}$
	$V_{BIAS} = 0$ , Not Switching			75	120	$\mu\text{A}$
Quiescent Current from BIAS	$V_{RUN/SS} = 0.2\text{V}$			0.01	0.5	$\mu\text{A}$
	$V_{BIAS} = 3\text{V}$ , Not Switching	●		50	120	$\mu\text{A}$
	$V_{BIAS} = 0$ , Not Switching			0	5	$\mu\text{A}$
Minimum Bias Voltage				2.7	3	V
Feedback Voltage		●	1.25 1.24	1.265 1.265	1.29 1.3	V V
FB Pin Bias Current (Note 3)	$V_{FB} = 1.25\text{V}$ , $V_C = 0.4\text{V}$	●		30	100	nA
FB Voltage Line Regulation	$4\text{V} < V_{IN} < 34\text{V}$			0.002	0.02	%/V
Error Amp $g_m$				330		$\mu\text{Mho}$
Error Amp Gain				800		
$V_C$ Source Current				65		$\mu\text{A}$
$V_C$ Sink Current				85		$\mu\text{A}$
$V_C$ Pin to Switch Current Gain				3.5		A/V
$V_C$ Clamp Voltage				2		V
Switching Frequency	$R_T = 8.66\text{k}$ $R_T = 29.4\text{k}$ $R_T = 187\text{k}$		2.5 1.25 250	2.8 1.4 300	3.1 1.55 350	MHz MHz kHz
Minimum Switch Off-Time		●		130	200	nS
Switch Current Limit	Duty Cycle = 5%		3.2	3.8	4.4	A
Switch $V_{CESAT}$	$I_{SW} = 2\text{A}$			360		mV
Boost Schottky Reverse Leakage	$V_{SW} = 10\text{V}$ , $V_{BIAS} = 0\text{V}$			0.02	2	$\mu\text{A}$
Minimum Boost Voltage (Note 4)		●		1.5	2.1	V
BOOST Pin Current	$I_{SW} = 1\text{A}$			18	35	mA
RUN/SS Pin Current	$V_{RUN/SS} = 2.5\text{V}$			5	10	$\mu\text{A}$
RUN/SS Input Voltage High			2.5			V
RUN/SS Input Voltage Low					0.2	V
PG Threshold Offset from Feedback Voltage	$V_{FB}$ Rising			122		mV
PG Hysteresis				5		mV
PG Leakage	$V_{PG} = 5\text{V}$			0.1	1	$\mu\text{A}$
PG Sink Current	$V_{PG} = 3\text{V}$	●	100	600		$\mu\text{A}$

**Note 1:** Stresses beyond those listed under Absolute Maximum Ratings may cause permanent damage to the device. Exposure to any Absolute Maximum Rating condition for extended periods may affect device reliability and lifetime.

**Note 2:** The LT3481E is guaranteed to meet performance specifications from  $0^\circ\text{C}$  to  $85^\circ\text{C}$ . Specifications over the  $-40^\circ\text{C}$  to  $85^\circ\text{C}$  operating temperature range are assured by design, characterization and correlation with statistical process controls. The LT3481I specifications are

guaranteed over the  $-40^\circ\text{C}$  to  $125^\circ\text{C}$  temperature range. The LT3481H specifications are guaranteed over the  $-40^\circ\text{C}$  to  $150^\circ\text{C}$  operating temperature range. High junction temperatures degrade operating lifetimes. Operating lifetime is derated at junction temperatures greater than  $125^\circ\text{C}$ .

**Note 3:** Bias current flows into the FB pin.

**Note 4:** This is the minimum voltage across the boost capacitor needed to guarantee full saturation of the switch.

TYPICAL PERFORMANCE CHARACTERISTICS

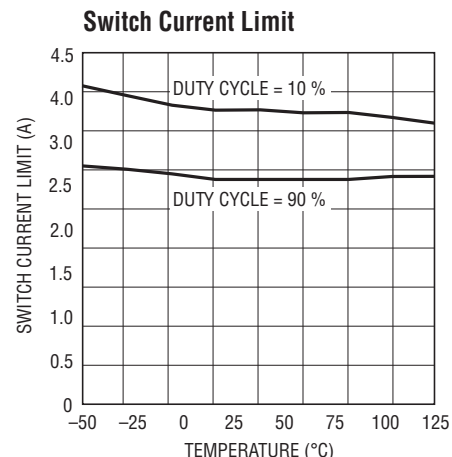
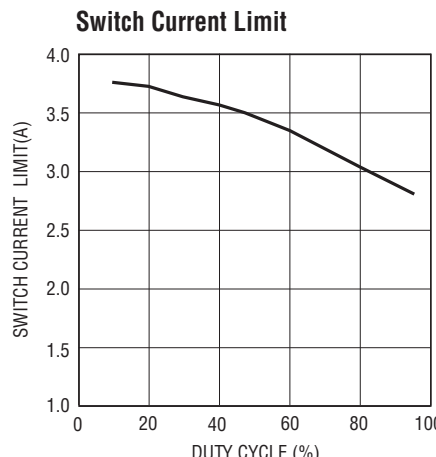
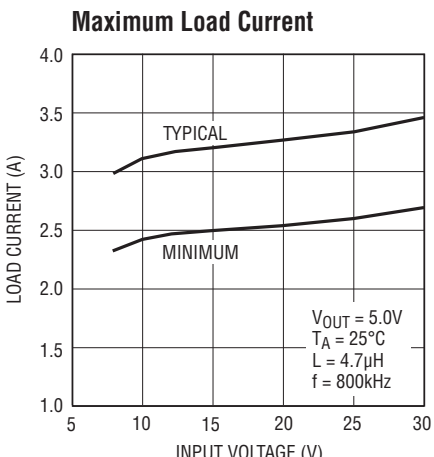
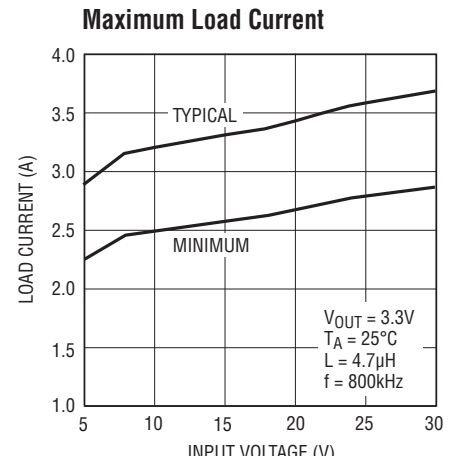
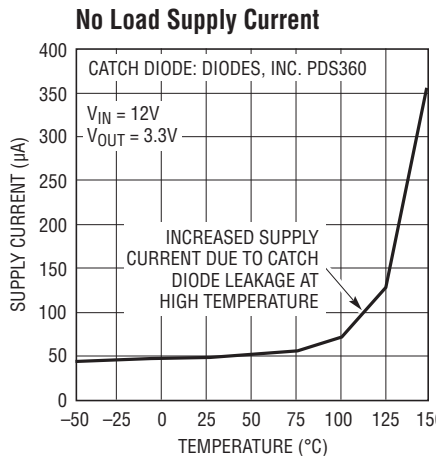
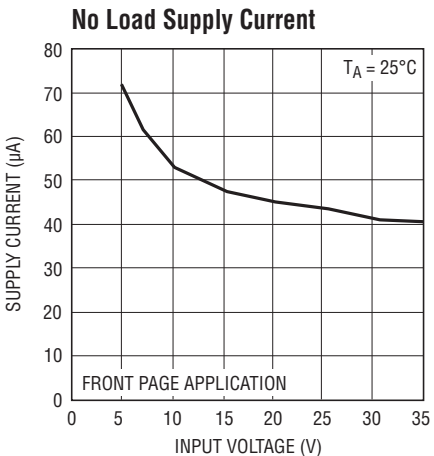
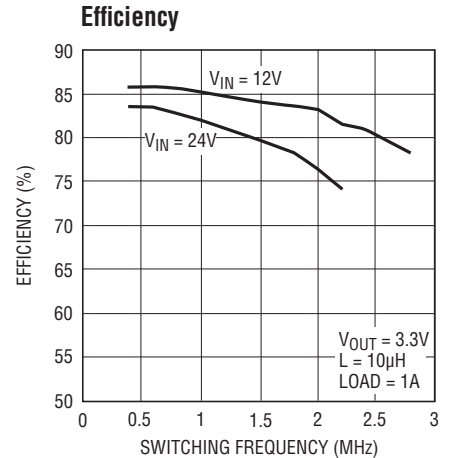
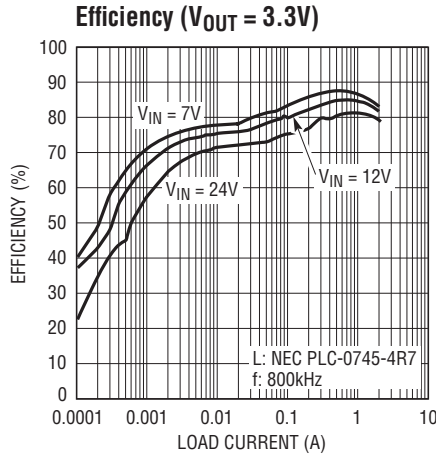
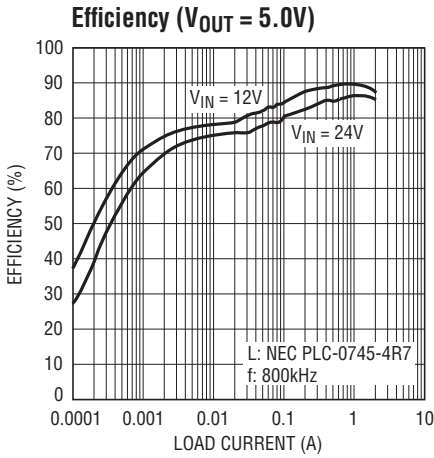

# TYPICAL PERFORMANCE CHARACTERISTICS

**Switch Voltage Drop**

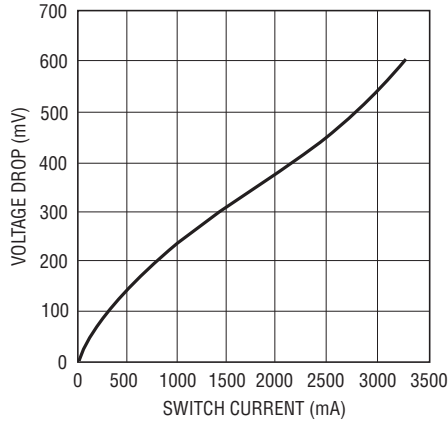

3481 G10

**BOOST Pin Current**

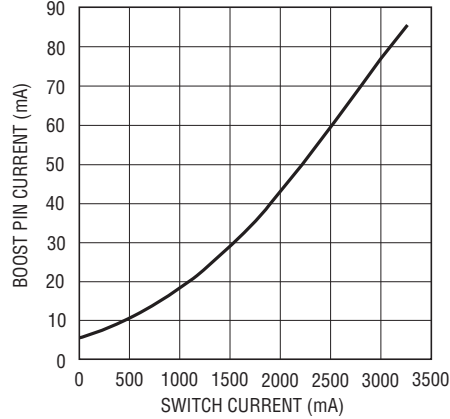

3481 G11

**Feedback Voltage**

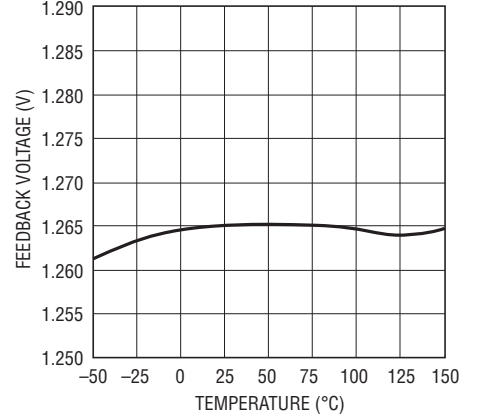

4381 G12

**Switching Frequency**

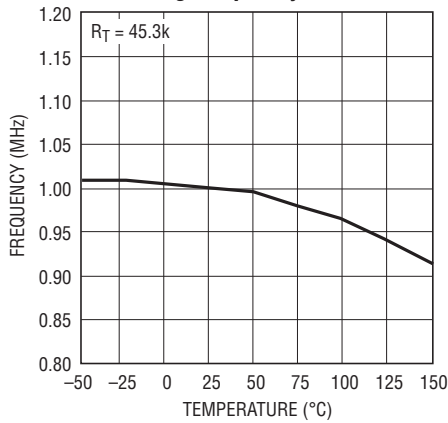

4381 G13

**Frequency Foldback**

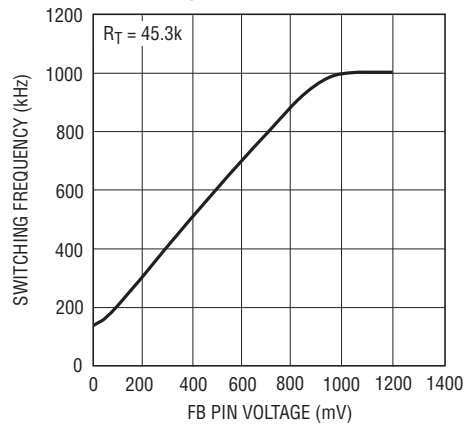

3481 G14

**Minimum Switch On-Time**

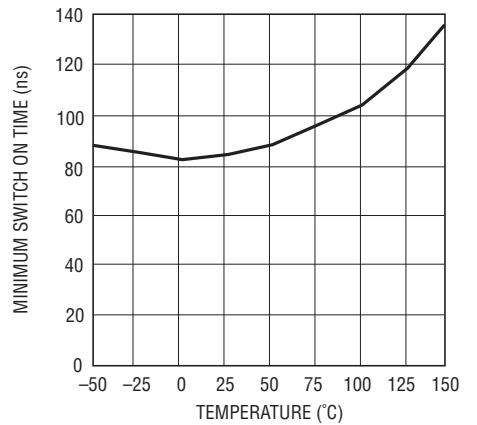

3481 G15

**Soft-Start**

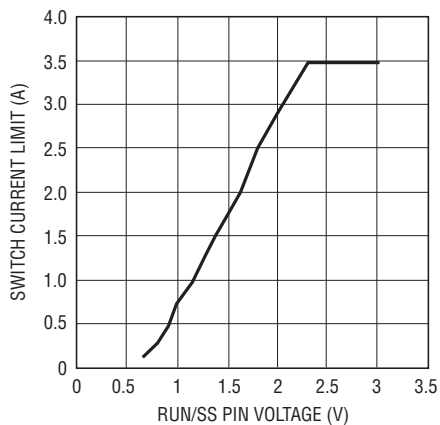

3481 G16

**RUN/SS Pin Current**

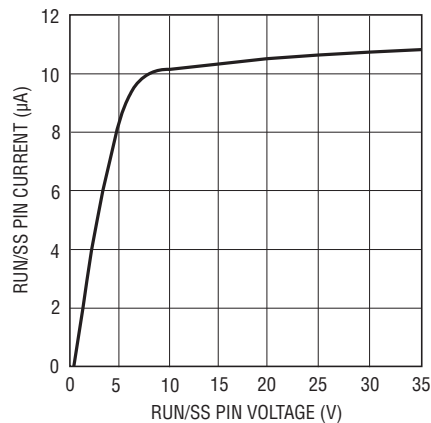

3481 G17

**Boost Diode**

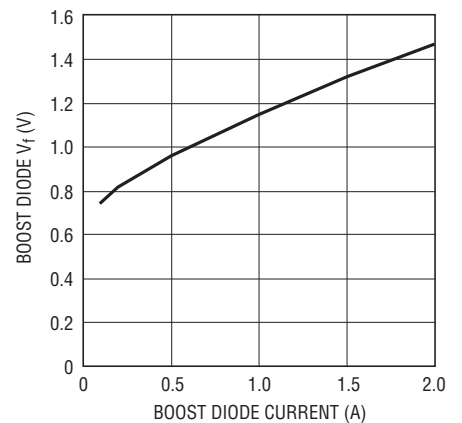

3481 G18

## TYPICAL PERFORMANCE CHARACTERISTICS

### Error Amp Output Current

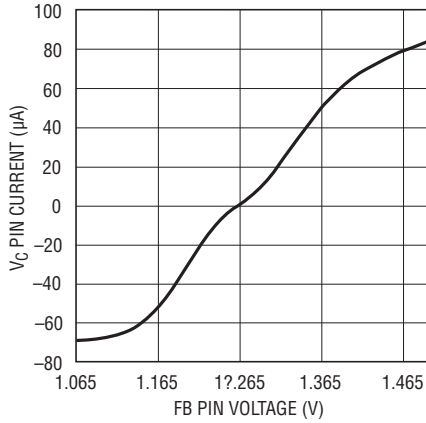

3481 G19

### Minimum Input Voltage

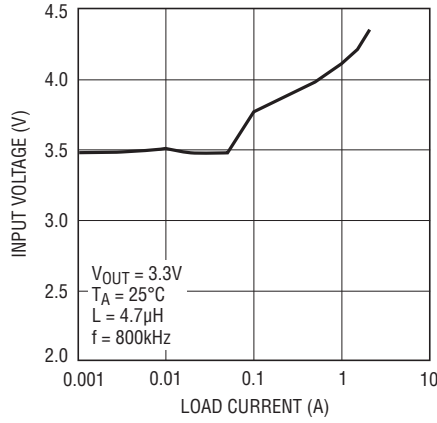

3481 G20

### Minimum Input Voltage

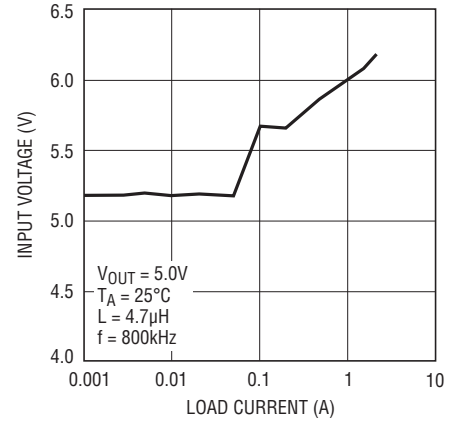

3481 G21

### V<sub>C</sub> Voltages

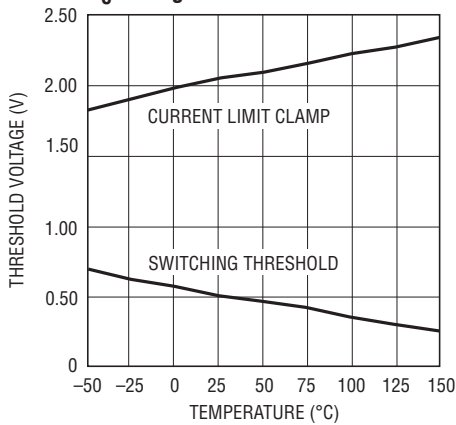

3481 G22

### Power Good Threshold

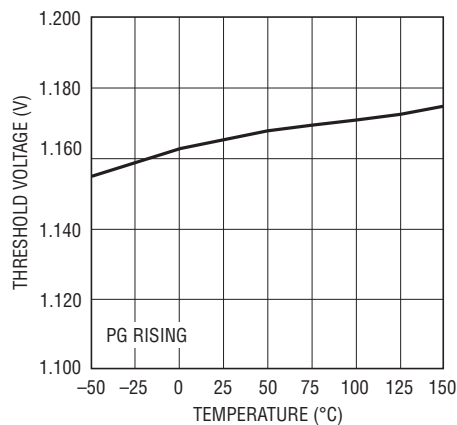

3481 G23

### Switching Waveforms; Burst Mode Operation

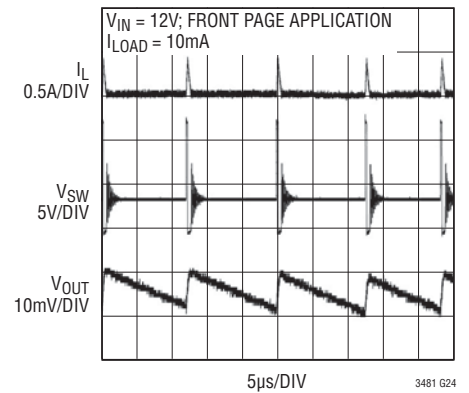

3481 G24

### Switching Waveforms; Transition from Burst Mode Operation to Full Frequency

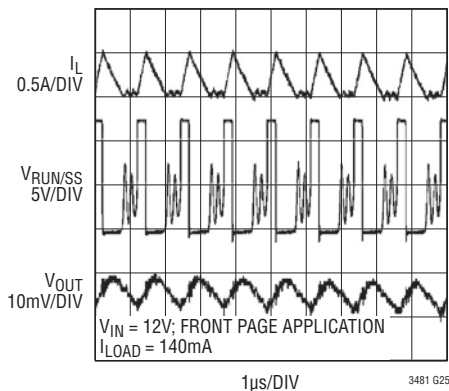

3481 G25

### Switching Waveforms; Full Frequency Continuous Operation

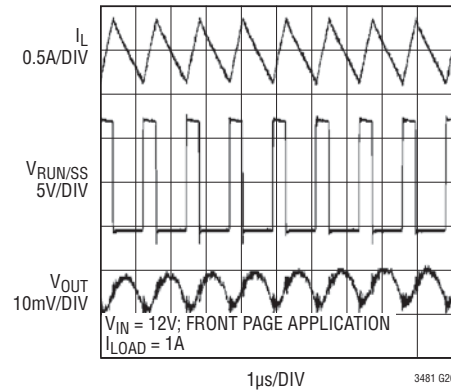

3481 G26

## PIN FUNCTIONS

**BD (Pin 1):** This pin connects to the anode of the boost Schottky diode.

**BOOST (Pin 2):** This pin is used to provide a drive voltage, higher than the input voltage, to the internal bipolar NPN power switch.

**SW (Pin 3):** The SW pin is the output of the internal power switch. Connect this pin to the inductor, catch diode and boost capacitor.

**V<sub>IN</sub> (Pin 4):** The V<sub>IN</sub> pin supplies current to the LT3481's internal regulator and to the internal power switch. This pin must be locally bypassed.

**RUN/SS (Pin 5):** The RUN/SS pin is used to put the LT3481 in shutdown mode. Tie to ground to shut down the LT3481. Tie to 2.3V or more for normal operation. If the shutdown feature is not used, tie this pin to the V<sub>IN</sub> pin. RUN/SS also provides a soft-start function; see the Applications Information section.

**PG (Pin 6):** The PG pin is the open-collector output of an internal comparator. PG remains low until the FB pin is within 10% of the final regulation voltage. PG output is valid when V<sub>IN</sub> is above 3.5V and RUN/SS is high.

**BIAS (Pin 7):** The BIAS pin supplies the current to the LT3481's internal regulator. Tie this pin to the lowest available voltage source above 3V (typically V<sub>OUT</sub>). This architecture increases efficiency especially when the input voltage is much higher than the output.

**FB (Pin 8):** The LT3481 regulates the FB pin to 1.265V. Connect the feedback resistor divider tap to this pin.

**V<sub>C</sub> (Pin 9):** The V<sub>C</sub> pin is the output of the internal error amplifier. The voltage on this pin controls the peak switch current. Tie an RC network from this pin to ground to compensate the control loop.

**RT (Pin 10):** Oscillator Resistor Input. Connecting a resistor to ground from this pin sets the switching frequency.

**Exposed Pad (Pin 11):** Ground. The Exposed Pad must be soldered to PCB.

## BLOCK DIAGRAM

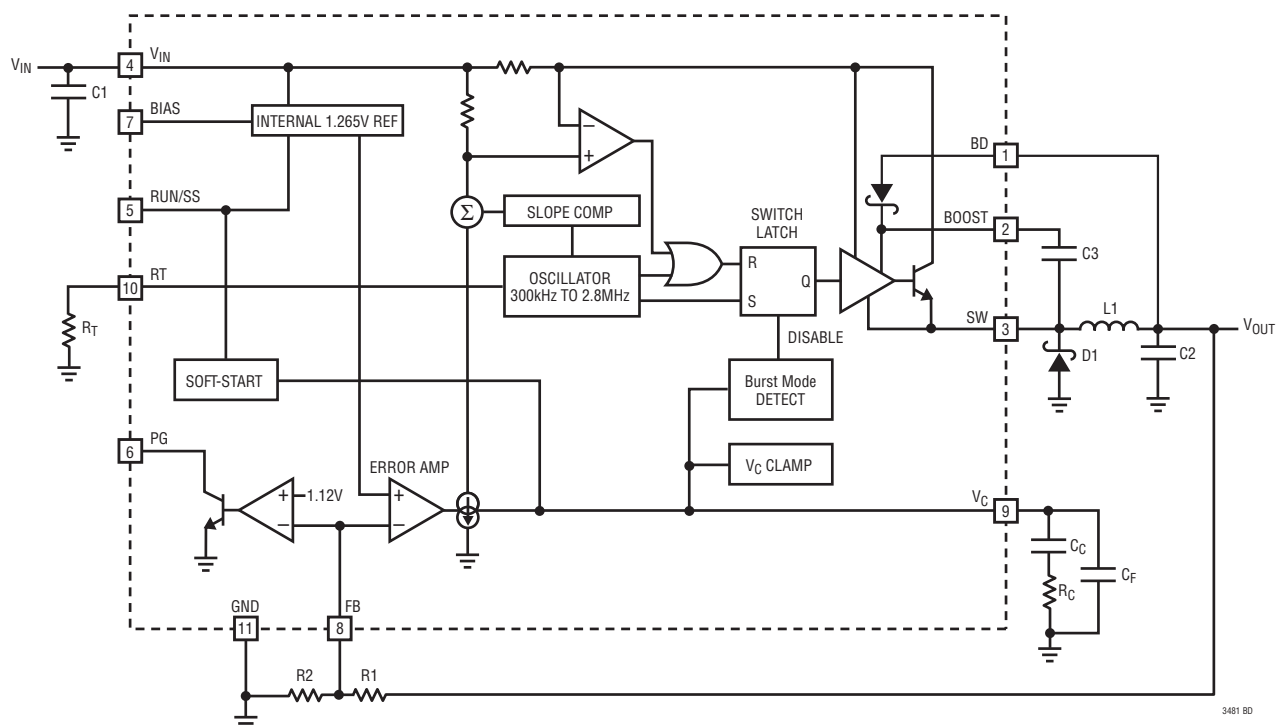

3481 BD

3481fc

## OPERATION

The LT3481 is a constant frequency, current mode step-down regulator. An oscillator, with frequency set by  $R_T$ , enables an RS flip-flop, turning on the internal power switch. An amplifier and comparator monitor the current flowing between the  $V_{IN}$  and SW pins, turning the switch off when this current reaches a level determined by the voltage at  $V_C$ . An error amplifier measures the output voltage through an external resistor divider tied to the FB pin and servos the  $V_C$  pin. If the error amplifier's output increases, more current is delivered to the output; if it decreases, less current is delivered. An active clamp on the  $V_C$  pin provides current limit. The  $V_C$  pin is also clamped to the voltage on the RUN/SS pin; soft-start is implemented by generating a voltage ramp at the RUN/SS pin using an external resistor and capacitor.

An internal regulator provides power to the control circuitry. The bias regulator normally draws power from the  $V_{IN}$  pin, but if the BIAS pin is connected to an external voltage higher than 3V bias power will be drawn from the external source (typically the regulated output voltage). This improves efficiency. The RUN/SS pin is used to place the LT3481 in shutdown, disconnecting the output and reducing the input current to less than  $1\mu\text{A}$ .

The switch driver operates from either the input or from the BOOST pin. An external capacitor and diode are used to generate a voltage at the BOOST pin that is higher than the input supply. This allows the driver to fully saturate the internal bipolar NPN power switch for efficient operation.

To further optimize efficiency, the LT3481 automatically switches to Burst Mode operation in light load situations. Between bursts, all circuitry associated with controlling the output switch is shut down reducing the input supply current to  $50\mu\text{A}$  in a typical application.

The oscillator reduces the LT3481's operating frequency when the voltage at the FB pin is low. This frequency foldback helps to control the output current during startup and overload.

The LT3481 contains a power good comparator which trips when the FB pin is at 91% of its regulated value. The PG output is an open-collector transistor that is off when the output is in regulation, allowing an external resistor to pull the PG pin high. Power good is valid when the LT3481 is enabled and  $V_{IN}$  is above 3.6V.



## APPLICATIONS INFORMATION

### FB Resistor Network

The output voltage is programmed with a resistor divider between the output and the FB pin. Choose the 1% resistors according to:

$$R1 = R2 \left( \frac{V_{OUT}}{1.265} - 1 \right)$$

Reference designators refer to the Block Diagram.

### Setting the Switching Frequency

The LT3481 uses a constant frequency PWM architecture that can be programmed to switch from 300kHz to 2.8MHz by using a resistor tied from the RT pin to ground. A table showing the necessary  $R_T$  value for a desired switching frequency is in Figure 1.

SWITCHING FREQUENCY (MHz)	$R_T$ VALUE (k $\Omega$ )
0.2	267
0.3	187
0.4	133
0.6	84.5
0.8	60.4
1.0	45.3
1.2	36.5
1.4	29.4
1.6	23.7
1.8	20.5
2.0	16.9
2.2	14.3
2.4	12.1
2.6	10.2
2.8	8.66

Figure 1. Switching Frequency vs  $R_T$  Value

### Operating Frequency Trade-Offs

Selection of the operating frequency is a trade-off between efficiency, component size, minimum dropout voltage, and maximum input voltage. The advantage of high frequency operation is that smaller inductor and capacitor values may be used. The disadvantages are lower efficiency, lower maximum input voltage, and higher dropout voltage. The highest acceptable switching frequency ( $f_{SW(MAX)}$ ) for a given application can be calculated as follows:

$$f_{SW(MAX)} = \frac{V_D + V_{OUT}}{t_{ON(MIN)} (V_D + V_{IN} - V_{SW})}$$

where  $V_{IN}$  is the typical input voltage,  $V_{OUT}$  is the output voltage, is the catch diode drop ( $\sim 0.5V$ ),  $V_{SW}$  is the internal switch drop ( $\sim 0.5V$  at max load). This equation shows that slower switching frequency is necessary to safely accommodate high  $V_{IN}/V_{OUT}$  ratio. Also, as shown in the next section, lower frequency allows a lower dropout voltage. The reason input voltage range depends on the switching frequency is because the LT3481 switch has finite minimum on and off times. The switch can turn on for a minimum of  $\sim 150ns$  and turn off for a minimum of  $\sim 150ns$ . This means that the minimum and maximum duty cycles are:

$$DC_{MIN} = f_{SW} t_{ON(MIN)}$$

$$DC_{MAX} = 1 - f_{SW} t_{OFF(MIN)}$$

where  $f_{SW}$  is the switching frequency, the  $t_{ON(MIN)}$  is the minimum switch on-time ( $\sim 150ns$ ), and the  $t_{OFF(MIN)}$  is the minimum switch off-time ( $\sim 150ns$ ). These equations show that duty cycle range increases when switching frequency is decreased.

A good choice of switching frequency should allow adequate input voltage range (see next section) and keep the inductor and capacitor values small.

### Input Voltage Range

The maximum input voltage for LT3481 applications depends on switching frequency, the absolute maximum ratings on  $V_{IN}$  and BOOST pins, and on operating mode.

If the output is in start-up or short-circuit operating modes, then  $V_{IN}$  must be below 34V and below the result of the following equation:

$$V_{IN(MAX)} = \frac{V_{OUT} + V_D}{f_{SW} t_{ON(MIN)}} - V_D + V_{SW}$$

where  $V_{IN(MAX)}$  is the maximum operating input voltage,  $V_{OUT}$  is the output voltage,  $V_D$  is the catch diode drop ( $\sim 0.5V$ ),  $V_{SW}$  is the internal switch drop ( $\sim 0.5V$  at max load),  $f_{SW}$  is the switching frequency (set by  $R_T$ ), and  $t_{ON(MIN)}$  is the minimum switch on-time ( $\sim 150ns$ ). Note that a higher switching frequency will depress the maximum operating input voltage. Conversely, a lower switching

## APPLICATIONS INFORMATION

frequency will be necessary to achieve safe operation at high input voltages.

If the output is in regulation and no short-circuit or start-up events are expected, then input voltage transients of up to 36V are acceptable regardless of the switching frequency. In this mode, the LT3481 may enter pulse-skipping operation where some switching pulses are skipped to maintain output regulation. In this mode the output voltage ripple and inductor current ripple will be higher than in normal operation.

The minimum input voltage is determined by either the LT3481's minimum operating voltage of ~3.6V or by its maximum duty cycle (see equation in previous section). The minimum input voltage due to duty cycle is:

$$V_{IN(MIN)} = \frac{V_{OUT} + V_D}{1 - f_{SW} t_{OFF(MIN)}} - V_D + V_{SW}$$

where  $V_{IN(MIN)}$  is the minimum input voltage, and  $t_{OFF(MIN)}$  is the minimum switch off-time (150ns). Note that higher switching frequency will increase the minimum input voltage. If a lower dropout voltage is desired, a lower switching frequency should be used.

### Inductor Selection

For a given input and output voltage, the inductor value and switching frequency will determine the ripple current. The ripple current  $\Delta I_L$  increases with higher  $V_{IN}$  or  $V_{OUT}$  and decreases with higher inductance and faster switching frequency. A reasonable starting point for selecting the ripple current is:

$$\Delta I_L = 0.4(I_{OUT(MAX)})$$

where  $I_{OUT(MAX)}$  is the maximum output load current. To guarantee sufficient output current, peak inductor current must be lower than the LT3481's switch current limit ( $I_{LIM}$ ). The peak inductor current is:

$$I_{L(PEAK)} = I_{OUT(MAX)} + \Delta I_L/2$$

where  $I_{L(PEAK)}$  is the peak inductor current,  $I_{OUT(MAX)}$  is the maximum output load current, and  $\Delta I_L$  is the inductor ripple current. The LT3481's switch current limit ( $I_{LIM}$ ) is

at least 3.5A at low duty cycles and decreases linearly to 2.5A at DC = 0.8. The maximum output current is a function of the inductor ripple current:

$$I_{OUT(MAX)} = I_{LIM} - \Delta I_L/2$$

Be sure to pick an inductor ripple current that provides sufficient maximum output current ( $I_{OUT(MAX)}$ ).

The largest inductor ripple current occurs at the highest  $V_{IN}$ . To guarantee that the ripple current stays below the specified maximum, the inductor value should be chosen according to the following equation:

$$L = \left( \frac{V_{OUT} + V_D}{f \Delta I_L} \right) \left( 1 - \frac{V_{OUT} + V_D}{V_{IN(MAX)}} \right)$$

where  $V_D$  is the voltage drop of the catch diode (~0.4V),  $V_{IN(MAX)}$  is the maximum input voltage,  $V_{OUT}$  is the output voltage,  $f_{SW}$  is the switching frequency (set by RT), and L is in the inductor value.

The inductor's RMS current rating must be greater than the maximum load current and its saturation current should be about 30% higher. For robust operation in fault conditions (start-up or short circuit) and high input voltage (>30V), the saturation current should be above 3.5A. To keep the efficiency high, the series resistance (DCR) should be less than 0.1 $\Omega$ , and the core material should be intended for high frequency applications. Table 1 lists several vendors and suitable types.

**Table 1. Inductor Vendors**

VENDOR	URL	PART SERIES	TYPE
Murata	www.murata.com	LQH55D	Open
TDK	www.componenttdk.com	SLF7045 SLF10145	Shielded Shielded
Toko	www.toko.com	D62CB D63CB D75C D75F	Shielded Shielded Shielded Open
Sumida	www.sumida.com	CR54 CDRH74 CDRH6D38 CR75	Open Shielded Shielded Open

## APPLICATIONS INFORMATION

Of course, such a simple design guide will not always result in the optimum inductor for your application. A larger value inductor provides a slightly higher maximum load current and will reduce the output voltage ripple. If your load is lower than 2A, then you can decrease the value of the inductor and operate with higher ripple current. This allows you to use a physically smaller inductor, or one with a lower DCR resulting in higher efficiency. There are several graphs in the Typical Performance Characteristics section of this data sheet that show the maximum load current as a function of input voltage and inductor value for several popular output voltages. Low inductance may result in discontinuous mode operation, which is okay but further reduces maximum load current. For details of maximum output current and discontinuous mode operation, see Linear Technology Application Note 44. Finally, for duty cycles greater than 50% ( $V_{OUT}/V_{IN} > 0.5$ ), there is a minimum inductance required to avoid subharmonic oscillations. See AN19.

### Input Capacitor

Bypass the input of the LT3481 circuit with a ceramic capacitor of X7R or X5R type. Y5V types have poor performance over temperature and applied voltage, and should not be used. A 4.7 $\mu$ F to 10 $\mu$ F ceramic capacitor is adequate to bypass the LT3481 and will easily handle the ripple current. Note that larger input capacitance is required when a lower switching frequency is used. If the input power source has high impedance, or there is significant inductance due to long wires or cables, additional bulk capacitance may be necessary. This can be provided with a low performance electrolytic capacitor.

Step-down regulators draw current from the input supply in pulses with very fast rise and fall times. The input capacitor is required to reduce the resulting voltage ripple at the LT3481 and to force this very high frequency switching current into a tight local loop, minimizing EMI. A 4.7 $\mu$ F capacitor is capable of this task, but only if it is placed close to the LT3481 and the catch diode (see the

PCB Layout section). A second precaution regarding the ceramic input capacitor concerns the maximum input voltage rating of the LT3481. A ceramic input capacitor combined with trace or cable inductance forms a high quality (under damped) tank circuit. If the LT3481 circuit is plugged into a live supply, the input voltage can ring to twice its nominal value, possibly exceeding the LT3481's voltage rating. This situation is easily avoided (see the Hot Plugging Safety section).

For space sensitive applications, a 2.2 $\mu$ F ceramic capacitor can be used for local bypassing of the LT3481 input. However, the lower input capacitance will result in increased input current ripple and input voltage ripple, and may couple noise into other circuitry. Also, the increased voltage ripple will raise the minimum operating voltage of the LT3481 to ~3.7V.

### Output Capacitor and Output Ripple

The output capacitor has two essential functions. Along with the inductor, it filters the square wave generated by the LT3481 to produce the DC output. In this role it determines the output ripple, and low impedance at the switching frequency is important. The second function is to store energy in order to satisfy transient loads and stabilize the LT3481's control loop. Ceramic capacitors have very low equivalent series resistance (ESR) and provide the best ripple performance. A good starting value is:

$$C_{OUT} = \frac{100}{V_{OUT} f_{SW}}$$

where  $f_{SW}$  is in MHz, and  $C_{OUT}$  is the recommended output capacitance in  $\mu$ F. Use X5R or X7R types. This choice will provide low output ripple and good transient response. Transient performance can be improved with a higher value capacitor if the compensation network is also adjusted to maintain the loop bandwidth. A lower value of output capacitor can be used to save space and cost but transient performance will suffer. See the Frequency Compensation section to choose an appropriate compensation network.

## APPLICATIONS INFORMATION

**Table 2. Capacitor Vendors**

VENDOR	PHONE	URL	PART SERIES	COMMANDS
Panasonic	(714) 373-7366	www.panasonic.com	Ceramic, Polymer, Tantalum	EEF Series
Kemet	(864) 963-6300	www.kemet.com	Ceramic, Tantalum	T494, T495
Sanyo	(408) 749-9714	www.sanyovideo.com	Ceramic, Polymer, Tantalum	POSCAP
Murata	(408) 436-1300	www.murata.com	Ceramic	
AVX		www.avxcorp.com	Ceramic, Tantalum	TPS Series
Taiyo Yuden	(864) 963-6300	www.taiyo-yuden.com	Ceramic	

When choosing a capacitor, look carefully through the data sheet to find out what the actual capacitance is under operating conditions (applied voltage and temperature). A physically larger capacitor, or one with a higher voltage rating, may be required. High performance tantalum or electrolytic capacitors can be used for the output capacitor. Low ESR is important, so choose one that is intended for use in switching regulators. The ESR should be specified by the supplier, and should be  $0.05\Omega$  or less. Such a capacitor will be larger than a ceramic capacitor and will have a larger capacitance, because the capacitor must be large to achieve low ESR. Table 2 lists several capacitor vendors.

### Catch Diode

The catch diode conducts current only during switch off time. Average forward current in normal operation can be calculated from:

$$I_{D(AVG)} = I_{OUT} (V_{IN} - V_{OUT})/V_{IN}$$

where  $I_{OUT}$  is the output load current. The only reason to consider a diode with a larger current rating than necessary for nominal operation is for the worst-case condition of shorted output. The diode current will then increase to the typical peak switch current. Peak reverse voltage is equal to the regulator input voltage. Use a diode with a reverse voltage rating greater than the input voltage. Table 3 lists several Schottky diodes and their manufacturers.

**Table 3. Diode Vendors**

PART NUMBER	$V_R$ (V)	$I_{AVE}$ (A)	$V_F$ AT 1A (mV)	$V_F$ AT 2A (mV)
On Semiconductor MBRM120E MBRM140	20 40	1 1	530 550	595
Diodes Inc. B120 B130 B220 B230 DFLS240L	20 30 20 30 40	1 1 2 2 2	500 500	500 500 500
International Rectifier 10BQ030 20BQ030	30 30	1 2	420	470 470

### Ceramic Capacitors

Ceramic capacitors are small, robust and have very low ESR. However, ceramic capacitors can cause problems when used with the LT3481 due to their piezoelectric nature. When in Burst Mode operation, the LT3481's switching frequency depends on the load current, and at very light loads the LT3481 can excite the ceramic capacitor at audio frequencies, generating audible noise. Since the LT3481 operates at a lower current limit during Burst Mode operation, the noise is typically very quiet to a casual ear. If this is unacceptable, use a high performance tantalum or electrolytic capacitor at the output.

## APPLICATIONS INFORMATION

A final precaution regarding ceramic capacitors concerns the maximum input voltage rating of the LT3481. A ceramic input capacitor combined with trace or cable inductance forms a high quality (under damped) tank circuit. If the LT3481 circuit is plugged into a live supply, the input voltage can ring to twice its nominal value, possibly exceeding the LT3481's rating. This situation is easily avoided (see the Hot Plugging Safely section).

### Frequency Compensation

The LT3481 uses current mode control to regulate the output. This simplifies loop compensation. In particular, the LT3481 does not require the ESR of the output capacitor for stability, so you are free to use ceramic capacitors to achieve low output ripple and small circuit size. Frequency compensation is provided by the components tied to the  $V_C$  pin, as shown in Figure 2. Generally a capacitor ( $C_C$ ) and a resistor ( $R_C$ ) in series to ground are used. In addition, there may be lower value capacitor in parallel. This capacitor ( $C_F$ ) is not part of the loop compensation but is used to filter noise at the switching frequency, and is required only if a phase-lead capacitor is used or if the output capacitor has high ESR.

Loop compensation determines the stability and transient performance. Designing the compensation network is a bit complicated and the best values depend on the application and in particular the type of output capacitor. A practical approach is to start with one of the circuits in this data sheet that is similar to your application and tune the compensation network to optimize the performance. Stability should then be checked across all operating conditions, including load current, input voltage and temperature. The LT1375 data sheet contains a more thorough discussion of loop compensation and describes how to test the stability using a transient load. Figure 2 shows an equivalent circuit for the LT3481 control loop. The error amplifier is a transconductance amplifier with finite output impedance. The power section, consisting of the modulator, power switch and inductor, is modeled as a transconductance amplifier generating an output current proportional to the voltage at the  $V_C$  pin. Note that the output capacitor integrates this current, and that the

capacitor on the  $V_C$  pin ( $C_C$ ) integrates the error amplifier output current, resulting in two poles in the loop. In most cases a zero is required and comes from either the output capacitor ESR or from a resistor  $R_C$  in series with  $C_C$ . This simple model works well as long as the value of the inductor is not too high and the loop crossover frequency is much lower than the switching frequency. A phase lead capacitor ( $C_{PL}$ ) across the feedback divider may improve the transient response. Figure 3 shows the transient response when the load current is stepped from 500mA to 1500mA and back to 500mA.

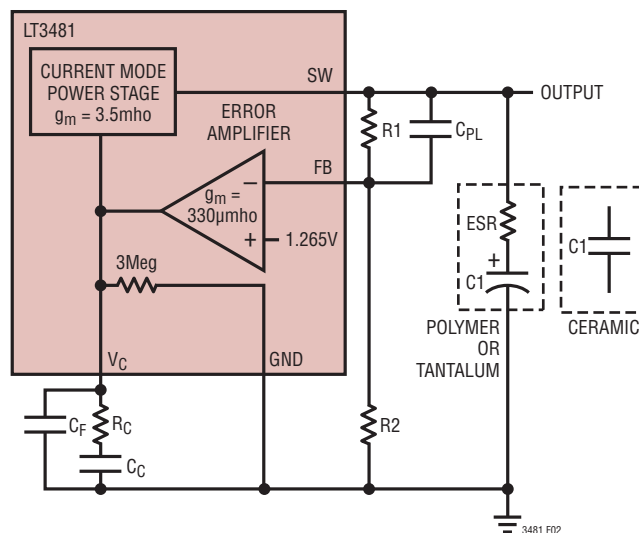

Figure 2. Model for Loop Response

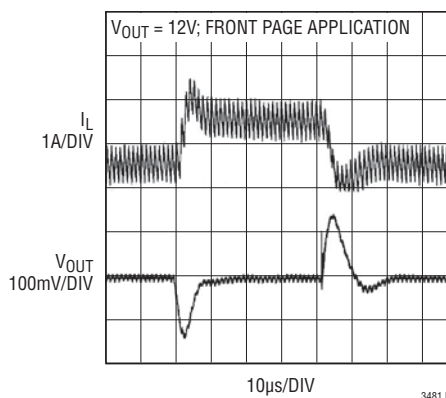

Figure 3. Transient Load Response of the LT3481 Front Page Application as the Load Current is Stepped from 500mA to 1500mA.  $V_{OUT} = 3.3V$

## APPLICATIONS INFORMATION

### Burst Mode Operation

To enhance efficiency at light loads, the LT3481 automatically switches to Burst Mode operation which keeps the output capacitor charged to the proper voltage while minimizing the input quiescent current. During Burst Mode operation, the LT3481 delivers single cycle bursts of current to the output capacitor followed by sleep periods where the output power is delivered to the load by the output capacitor. In addition,  $V_{IN}$  and BIAS quiescent currents are reduced to typically  $20\mu A$  and  $50\mu A$  respectively during the sleep time. As the load current decreases towards a no load condition, the percentage of time that the LT3481 operates in sleep mode increases and the average input current is greatly reduced resulting in higher efficiency. See Figure 4.

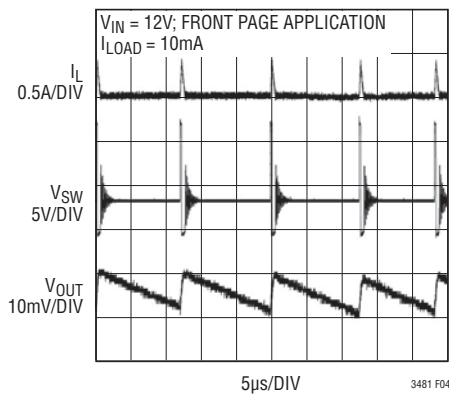
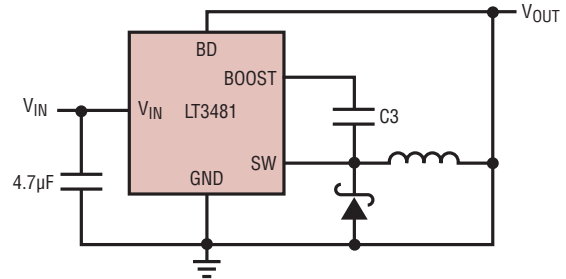

Figure 4. Burst Mode Operation

### BOOST and BIAS Pin Considerations

Capacitor C3 and the internal boost Schottky diode (see the Block Diagram) are used to generate a boost voltage that is higher than the input voltage. In most cases a  $0.22\mu F$  capacitor will work well. Figure 2 shows three ways to arrange the boost circuit. The BOOST pin must be more than 2.3V above the SW pin for best efficiency. For outputs of 3V and above, the standard circuit (Figure 5a) is best. For outputs between 2.8V and 3V, use a  $1\mu F$  boost capacitor. A 2.5V output presents a special case because it is marginally adequate to support the boosted drive stage while using the internal boost diode. For reliable BOOST pin operation with 2.5V outputs use a good external Schottky diode (such as the ON Semi MBR0540), and a  $1\mu F$  boost capacitor (see Figure 5b). For lower output voltages the

boost diode can be tied to the input (Figure 5c), or to another supply greater than 2.8V. The circuit in Figure 5a is more efficient because the BOOST pin current and BIAS pin quiescent current comes from a lower voltage source. You must also be sure that the maximum voltage ratings of the BOOST and BIAS pins are not exceeded.



(5a) For  $V_{OUT} > 2.8V$

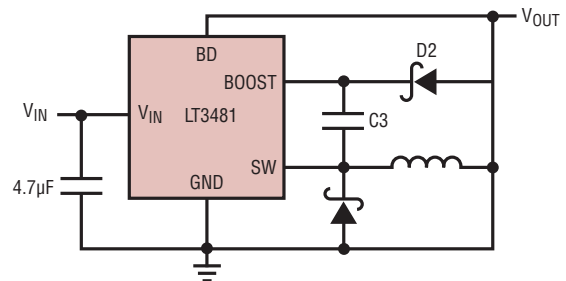

(5b) For  $2.5V < V_{OUT} < 2.8V$

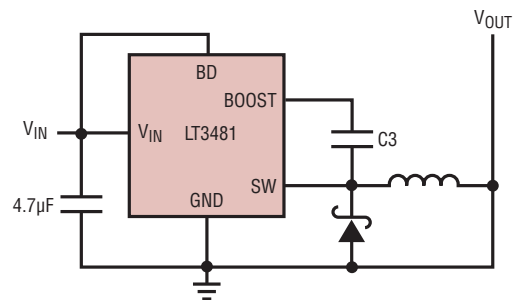

(5c) For  $V_{OUT} < 2.5V$

Figure 5. Three Circuits For Generating The Boost Voltage

The minimum operating voltage of an LT3481 application is limited by the minimum input voltage (3.6V) and by the maximum duty cycle as outlined in a previous section. For proper startup, the minimum input voltage is also limited by the boost circuit. If the input voltage is ramped slowly, or the LT3481 is turned on with its RUN/SS pin when the output is already in regulation, then the boost capacitor

## APPLICATIONS INFORMATION

may not be fully charged. Because the boost capacitor is charged with the energy stored in the inductor, the circuit will rely on some minimum load current to get the boost circuit running properly. This minimum load will depend on input and output voltages, and on the arrangement of the boost circuit. The minimum load generally goes to zero once the circuit has started. Figure 6 shows a plot of minimum load to start and to run as a function of input voltage. In many cases the discharged output capacitor will present a load to the switcher, which will allow it to start. The plots show the worst-case situation where  $V_{IN}$  is ramping very slowly. For lower start-up voltage, the boost diode can be tied to  $V_{IN}$ ; however, this restricts the input range to one-half of the absolute maximum rating of the BOOST pin.

At light loads, the inductor current becomes discontinuous and the effective duty cycle can be very high. This reduces the minimum input voltage to approximately 300mV above  $V_{OUT}$ . At higher load currents, the inductor current is continuous and the duty cycle is limited by the maximum duty cycle of the LT3481, requiring a higher input voltage to maintain regulation.

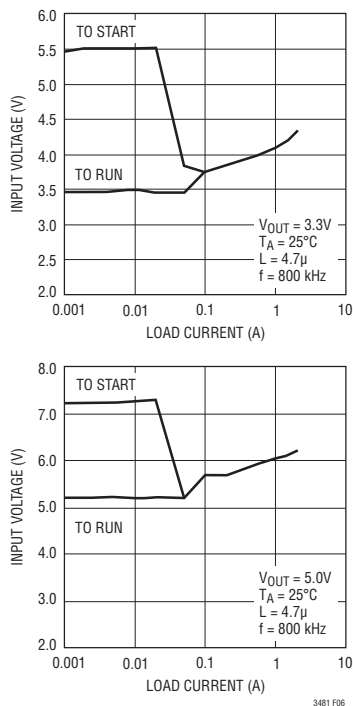

Figure 6. The Minimum Input Voltage Depends on Output Voltage, Load Current and Boost Circuit

### Soft-Start

The RUN/SS pin can be used to soft-start the LT3481, reducing the maximum input current during start-up. The RUN/SS pin is driven through an external RC filter to create a voltage ramp at this pin. Figure 7 shows the start-up and shutdown waveforms with the soft-start circuit. By choosing a large RC time constant, the peak start-up current can be reduced to the current that is required to regulate the output, with no overshoot. Choose the value of the resistor so that it can supply  $20\mu A$  when the RUN/SS pin reaches 2.3V.

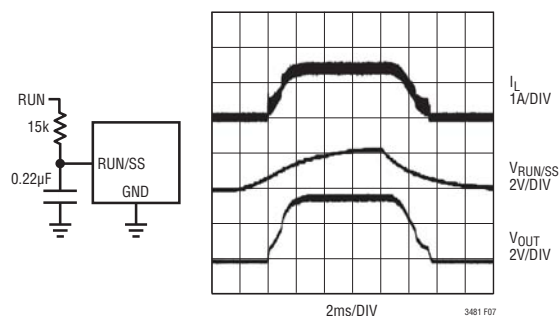

Figure 7. To Soft-Start the LT3481, Add a Resistor and Capacitor to the RUN/SS Pin

### Synchronization

The internal oscillator of the LT3481 can be synchronized to an external 275kHz to 475kHz clock by using a 5pF to 20pF capacitor to connect the clock signal to the RT pin. The resistor tying the RT pin to ground should be chosen such that the LT3481 oscillates 20% lower than the intended synchronization frequency (see Setting the Switching Frequency section).

The LT3481 should not be synchronized until its output is near regulation as indicated by the PG flag. This can be done with the system microcontroller/microprocessor or with a discrete circuit by using the PG output. If a sync signal is applied while the PG is low, the LT3481 may exhibit erratic operation. See Typical Applications.

When applying a sync signal, positive clock transitions reset LT3481's internal clock and negative transitions initiate a switch cycle. The amplitude of the sync signal must be at least 2V. The sync signal duty cycle can range

## APPLICATIONS INFORMATION

from 5% up to a maximum value given by the following equation:

$$DC_{\text{SYNC(MAX)}} = \left( 1 - \frac{V_{\text{OUT}} + V_D}{V_{\text{IN}} - V_{\text{SW}} + V_D} \right) - f_{\text{SW}} \cdot 600\text{ns}$$

where  $V_{\text{OUT}}$  is the programmed output voltage,  $V_D$  is the diode forward drop,  $V_{\text{IN}}$  is the typical input voltage,  $V_{\text{SW}}$  is the switch drop, and  $f_{\text{SW}}$  is the desired switching frequency. For example, a 24V input to 5V output at 300kHz can be synchronized to a square wave with a maximum duty cycle of 60%. For some applications, such as 12V<sub>IN</sub> to 5V<sub>OUT</sub> at 350kHz, the maximum allowable sync duty cycle will be less than 50%. If a low duty cycle clock cannot be obtained from the system, then a one-shot should be used between the sync signal and the LT3481. See Typical Applications.

The value of the coupling capacitor which connects the clock signal to the RT pin should be chosen based on the clock signal amplitude. Good starting values for 3.3V and 5V clock signals are 10pF and 5pF, respectively. These values should be tested and adjusted for each individual application to assure reliable operation.

Caution should be used when synchronizing more than 50% above the initial switching frequency (as set by the R<sub>T</sub> resistor) because at higher clock frequencies the amplitude of the internal slope compensation used to prevent subharmonic switching is reduced. This type of subharmonic switching only occurs at input voltages less than twice output voltage. Higher inductor values will tend to reduce this problem.

### Shorted and Reversed Input Protection

If the inductor is chosen so that it won't saturate excessively, an LT3481 buck regulator will tolerate a shorted output. There is another situation to consider in systems where the output will be held high when the input to the LT3481 is absent. This may occur in battery charging applications or in battery backup systems where a battery or some other supply is diode ORed with the LT3481's output. If the  $V_{\text{IN}}$  pin is allowed to float and the RUN/SS pin is held high (either by a logic signal or because it is tied to  $V_{\text{IN}}$ ), then the LT3481's internal circuitry will pull its quiescent current through its SW pin. This is fine if

your system can tolerate a few mA in this state. If you ground the RUN/SS pin, the SW pin current will drop to essentially zero. However, if the  $V_{\text{IN}}$  pin is grounded while the output is held high, then parasitic diodes inside the LT3481 can pull large currents from the output through the SW pin and the  $V_{\text{IN}}$  pin. Figure 8 shows a circuit that will run only when the input voltage is present and that protects against a shorted or reversed input.

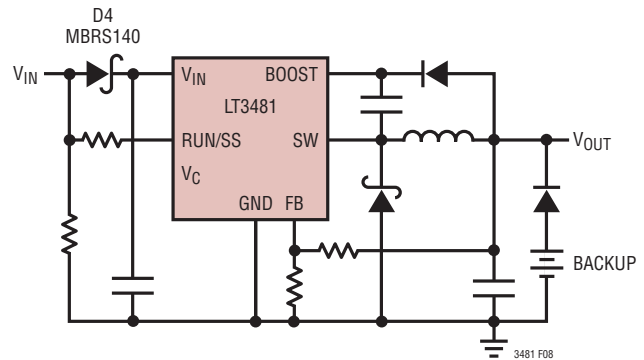

**Figure 8. Diode D4 Prevents a Shorted Input from Discharging a Backup Battery Tied to the Output. It Also Protects the Circuit from a Reversed Input. The LT3481 Runs Only When the Input is Present**

### PCB Layout

For proper operation and minimum EMI, care must be taken during printed circuit board layout. Figure 9 shows the recommended component placement with trace, ground plane and via locations. Note that large, switched currents flow in the LT3481's  $V_{\text{IN}}$  and SW pins, the catch diode (D1) and the input capacitor (C1). The loop formed by these components should be as small as possible. These components, along with the inductor and output capacitor, should be placed on the same side of the circuit board, and their connections should be made on that layer. Place a local, unbroken ground plane below these components. The SW and BOOST nodes should be as small as possible. Finally, keep the FB and  $V_C$  nodes small so that the ground traces will shield them from the SW and BOOST nodes. The Exposed Pad on the bottom of the package must be soldered to ground so that the pad acts as a heat sink. To keep thermal resistance low, extend the ground plane as much as possible, and add thermal vias under and near the LT3481 to additional ground planes within the circuit board and on the bottom side.

3481fc



APPLICATIONS INFORMATION

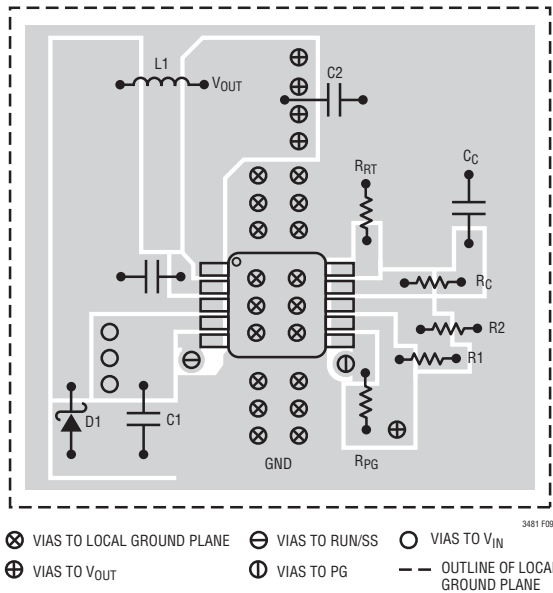

Figure 9. A Good PCB Layout Ensures Proper, Low EMI Operation

Hot Plugging Safely

The small size, robustness and low impedance of ceramic capacitors make them an attractive option for the input bypass capacitor of LT3481 circuits. However, these capacitors can cause problems if the LT3481 is plugged into a live supply (see Linear Technology Application Note 88 for a complete discussion). The low loss ceramic capacitor, combined with stray inductance in series with the power source, forms an under damped tank circuit, and the voltage at the  $V_{IN}$  pin of the LT3481 can ring to twice the nominal input voltage, possibly exceeding the LT3481's rating and damaging the part. If the input supply is poorly controlled or the user will be plugging the LT3481 into an energized supply, the input network should be designed to prevent this overshoot. Figure 10 shows the waveforms that result when an LT3481 circuit is connected to a 24V supply through six feet of 24-gauge twisted pair. The

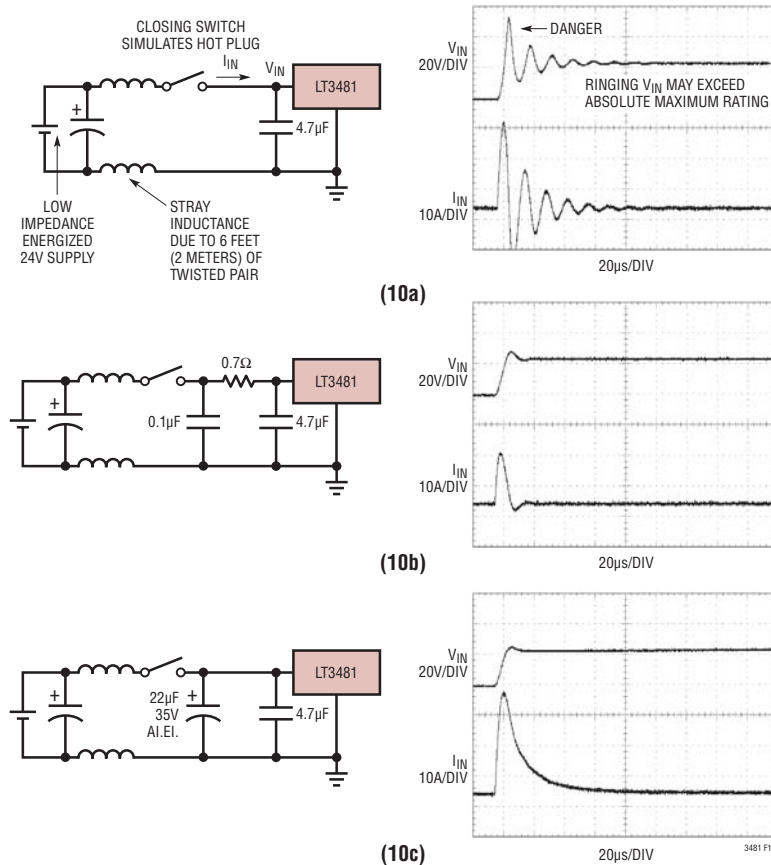

Figure 10. A Well Chosen Input Network Prevents Input Voltage Overshoot and Ensures Reliable Operation when the LT3481 is Connected to a Live Supply

## APPLICATIONS INFORMATION

first plot is the response with a 4.7 $\mu$ F ceramic capacitor at the input. The input voltage rings as high as 50V and the input current peaks at 26A. A good solution is shown in Figure 10b. A 0.7 $\Omega$  resistor is added in series with the input to eliminate the voltage overshoot (it also reduces the peak input current). A 0.1 $\mu$ F capacitor improves high frequency filtering. For high input voltages its impact on efficiency is minor, reducing efficiency by 1.5 percent for a 5V output at full load operating from 24V.

### High Temperature Considerations

The PCB must provide heat sinking to keep the LT3481 cool. The Exposed Pad on the bottom of the package must be soldered to a ground plane. This ground should be tied to large copper layers below with thermal vias; these layers will spread the heat dissipated by the LT3481. Place additional vias can reduce thermal resistance further. With these steps, the thermal resistance from die (or junction) to ambient can be reduced to  $\theta_{JA} = 35^{\circ}\text{C}/\text{W}$  or less. With 100LFPM airflow, this resistance can fall by another 25%. Further increases in airflow will lead to lower thermal resistance. Because of the large output current capability of

the LT3481, it is possible to dissipate enough heat to raise the junction temperature beyond the absolute maximum of 125 $^{\circ}\text{C}$  (150 $^{\circ}\text{C}$  for the H grade). When operating at high ambient temperatures, the maximum load current should be derated as the ambient temperature approaches 125 $^{\circ}\text{C}$  (150 $^{\circ}\text{C}$  for the H grade).

Power dissipation within the LT3481 can be estimated by calculating the total power loss from an efficiency measurement and subtracting the catch diode loss. The die temperature is calculated by multiplying the LT3481 power dissipation by the thermal resistance from junction to ambient.

### Other Linear Technology Publications

Application Notes 19, 35 and 44 contain more detailed descriptions and design information for buck regulators and other switching regulators. The LT1376 data sheet has a more extensive discussion of output ripple, loop compensation and stability testing. Design Note 100 shows how to generate a bipolar output supply using a buck regulator.

## TYPICAL APPLICATIONS

5V Step-Down Converter

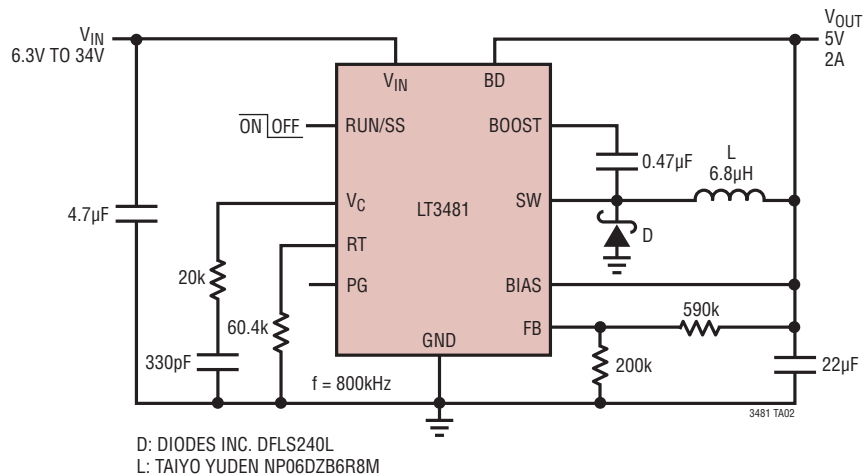

TYPICAL APPLICATIONS

3.3V Step-Down Converter

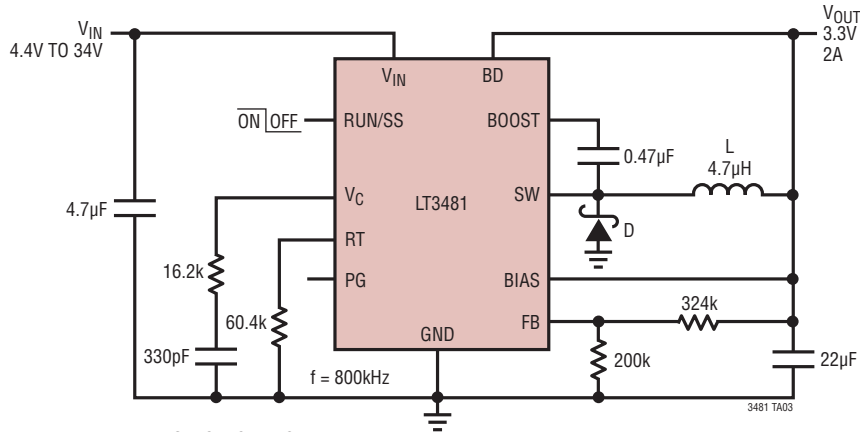

D: DIODES INC. DFSL240L  
L: TAIYO YUDEN NP06DZB4R7M

2.5V Step-Down Converter

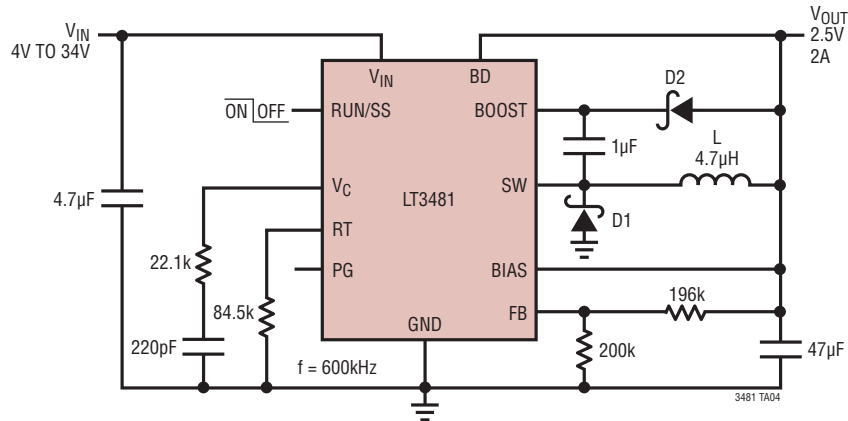

D1: DIODES INC. DFSL240L  
D2: MBR0540  
L: TAIYO YUDEN NP06DZB4R7M

5V, 2MHz Step-Down Converter

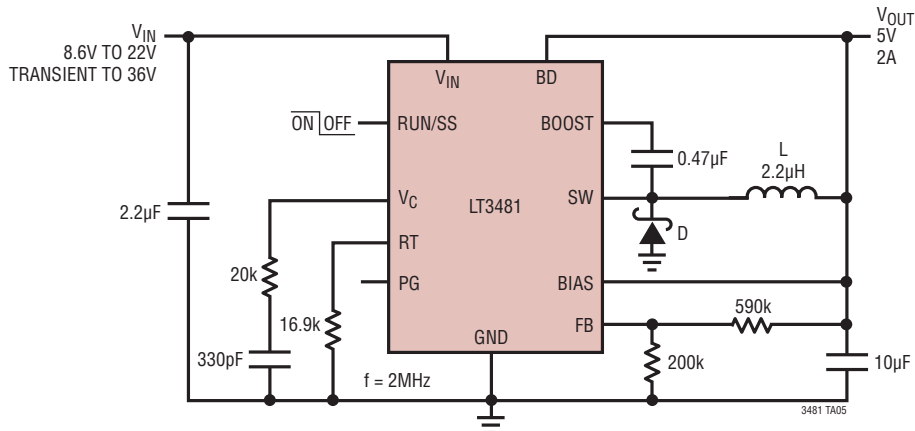

D: DIODES INC. DFSL240L  
L: SUMIDA CDRM4D22/HP-2R2

## TYPICAL APPLICATIONS

### 12V Step-Down Converter

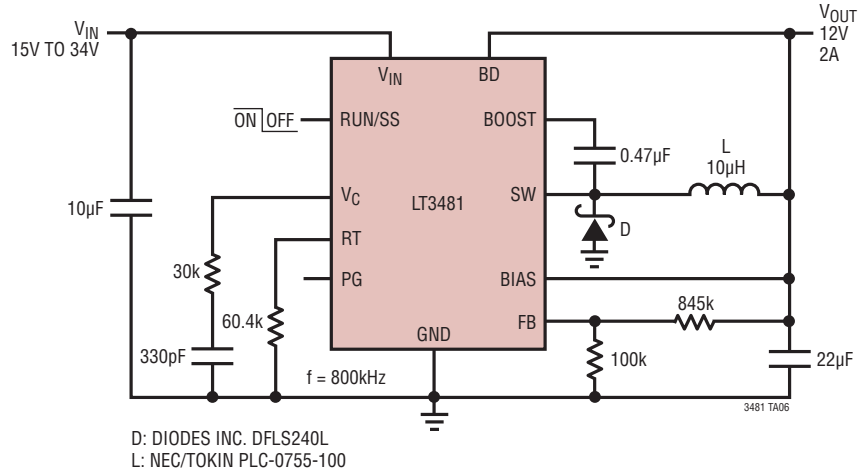

### 5V Step-Down Converter with Sync Input

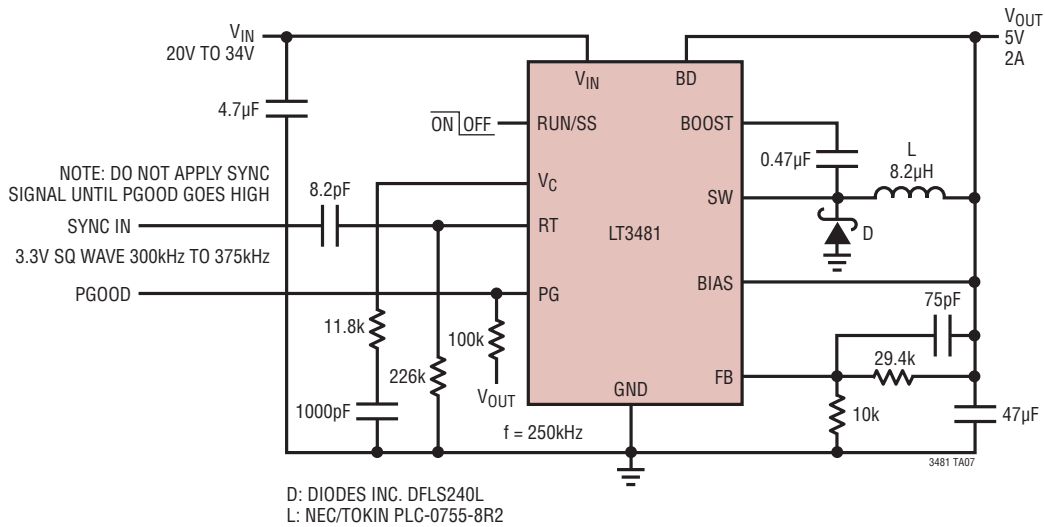

TYPICAL APPLICATIONS

5V Step-Down Converter with Sync and One-Shot

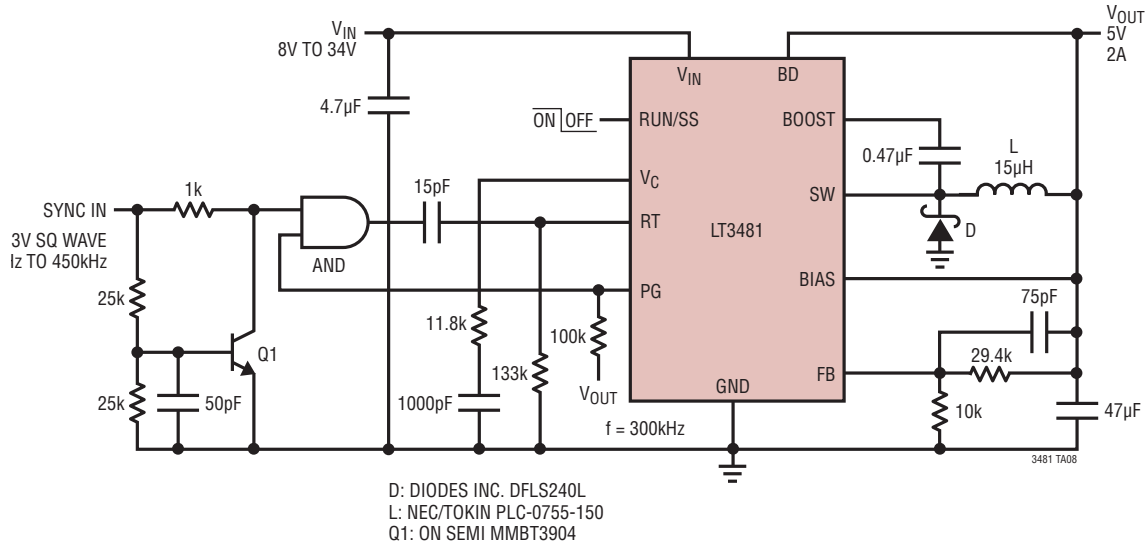

1.8V Step-Down Converter

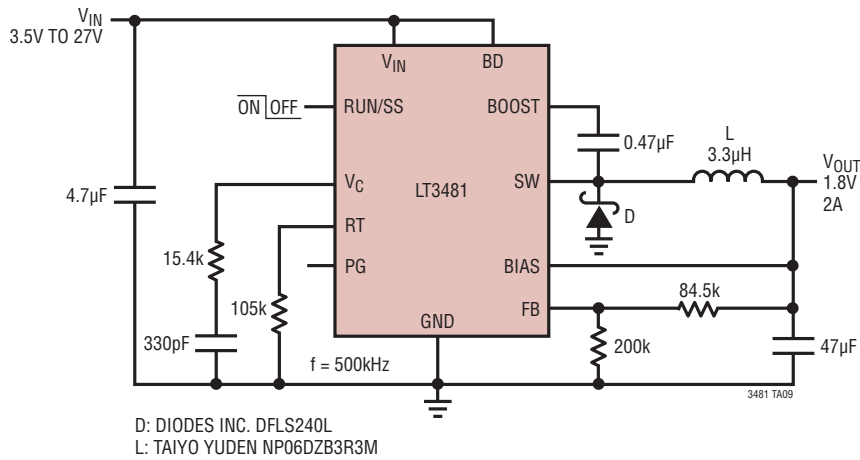

**PACKAGE DESCRIPTION**

**DD Package**  
**10-Lead Plastic DFN (3mm × 3mm)**  
 (Reference LTC DWG # 05-08-1699 Rev B)

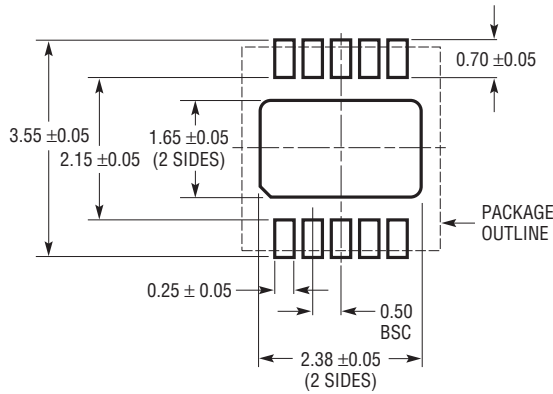

**RECOMMENDED SOLDER PAD PITCH AND DIMENSIONS**

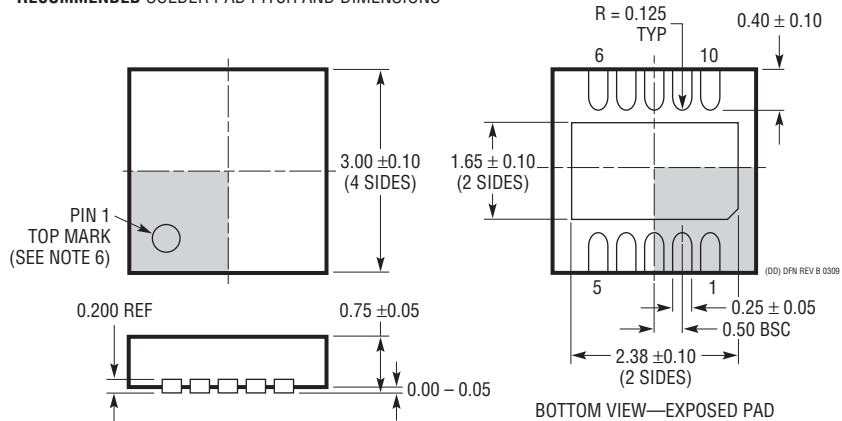

**NOTE:**

1. DRAWING TO BE MADE A JEDEC PACKAGE OUTLINE M0-229 VARIATION OF (WEED-2). CHECK THE LTC WEBSITE DATA SHEET FOR CURRENT STATUS OF VARIATION ASSIGNMENT
2. DRAWING NOT TO SCALE
3. ALL DIMENSIONS ARE IN MILLIMETERS
4. DIMENSIONS OF EXPOSED PAD ON BOTTOM OF PACKAGE DO NOT INCLUDE MOLD FLASH. MOLD FLASH, IF PRESENT, SHALL NOT EXCEED 0.15mm ON ANY SIDE
5. EXPOSED PAD SHALL BE SOLDER PLATED
6. SHADED AREA IS ONLY A REFERENCE FOR PIN 1 LOCATION ON THE TOP AND BOTTOM OF PACKAGE

# PACKAGE DESCRIPTION

## MSE Package 10-Lead Plastic MSOP, Exposed Die Pad (Reference LTC DWG # 05-08-1664 Rev C)

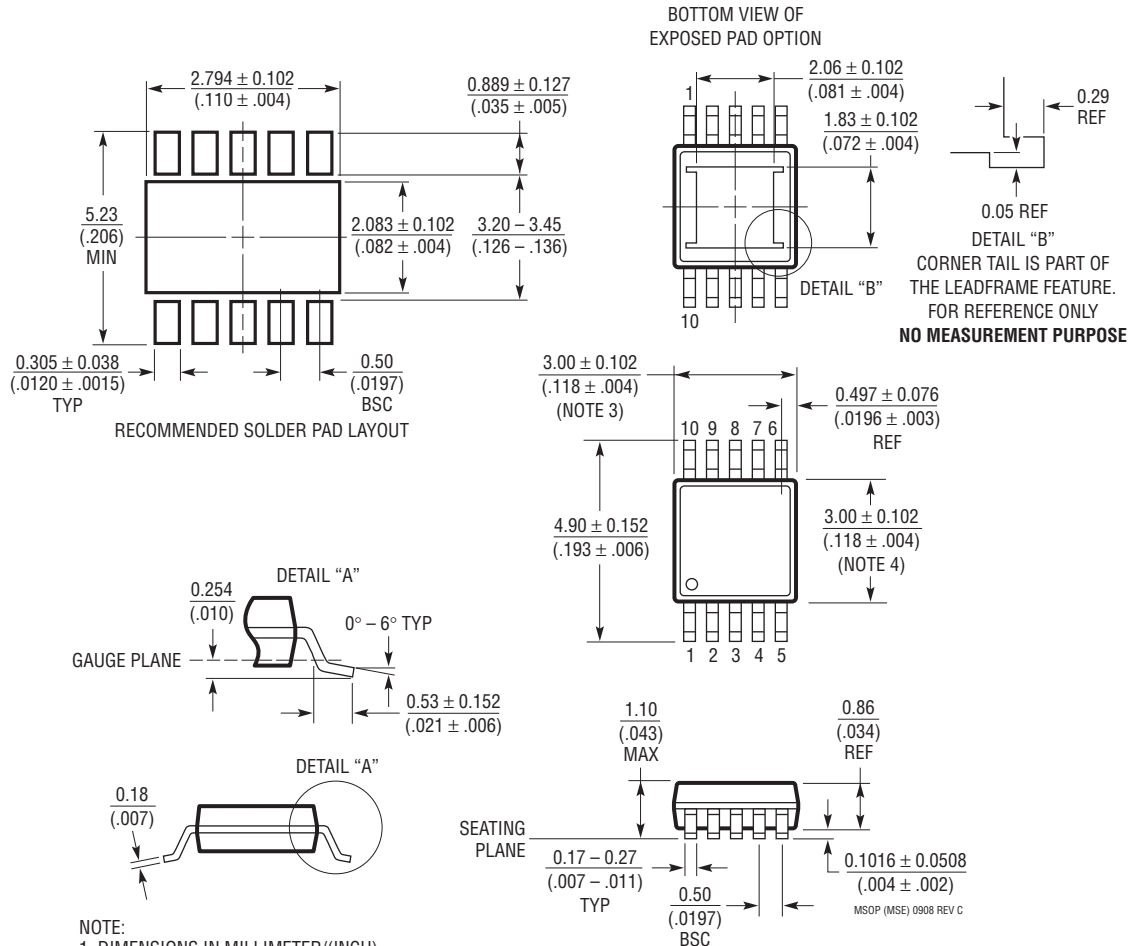

- NOTE:
1. DIMENSIONS IN MILLIMETER/(INCH)
  2. DRAWING NOT TO SCALE
  3. DIMENSION DOES NOT INCLUDE MOLD FLASH, PROTRUSIONS OR GATE BURRS.  
MOLD FLASH, PROTRUSIONS OR GATE BURRS SHALL NOT EXCEED 0.152mm (.006") PER SIDE
  4. DIMENSION DOES NOT INCLUDE INTERLEAD FLASH OR PROTRUSIONS.  
INTERLEAD FLASH OR PROTRUSIONS SHALL NOT EXCEED 0.152mm (.006") PER SIDE
  5. LEAD COPLANARITY (BOTTOM OF LEADS AFTER FORMING) SHALL BE 0.102mm (.004") MAX

## TYPICAL APPLICATION

### 1.265V Step-Down Converter

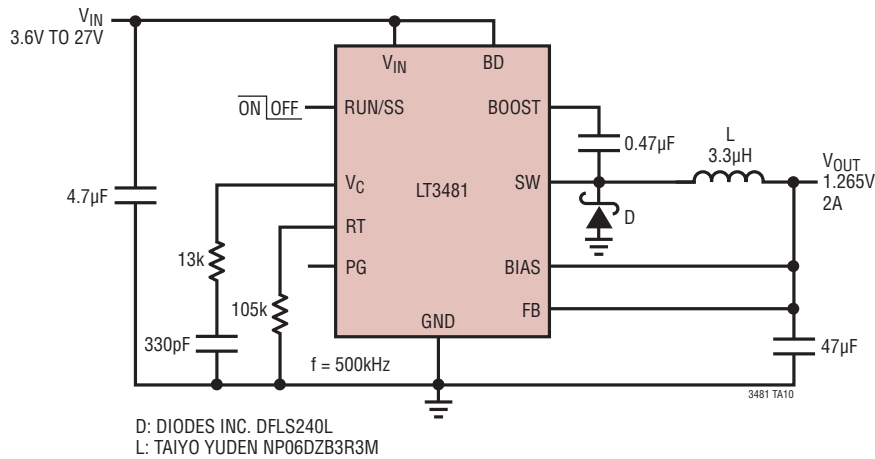

## RELATED PARTS

PART NUMBER	DESCRIPTION	COMMENTS
LT1933	500mA ( $I_{OUT}$ ), 500kHz Step-Down Switching Regulator in SOT-23	$V_{IN}$ : 3.6V to 36V, $V_{OUT(MIN)}$ = 1.2V, $I_Q$ = 1.6mA, $I_{SD}$ < 1µA, ThinSOT™ Package
LT3437	60V, 400mA ( $I_{OUT}$ ), MicroPower Step-Down DC/DC Converter with Burst Mode Operation	$V_{IN}$ : 3.3V to 80V, $V_{OUT(MIN)}$ = 1.25V, $I_Q$ = 100µA, $I_{SD}$ < 1µA, DFN Package
LT1936	36V, 1.4A ( $I_{OUT}$ ), 500kHz High Efficiency Step-Down DC/DC Converter	$V_{IN}$ : 3.6V to 36V, $V_{OUT(MIN)}$ = 1.2V, $I_Q$ = 1.9mA, $I_{SD}$ < 1µA, MS8E Package
LT3493	36V, 1.2A ( $I_{OUT}$ ), 750kHz High Efficiency Step-Down DC/DC Converter	$V_{IN}$ : 3.6V to 40V, $V_{OUT(MIN)}$ = 0.8V, $I_Q$ = 1.9mA, $I_{SD}$ < 1µA, DFN Package
LT1976/LT1977	60V, 1.2A ( $I_{OUT}$ ), 200kHz/500kHz, High Efficiency Step-Down DC/DC Converter with Burst Mode Operation	$V_{IN}$ : 3.3V to 60V, $V_{OUT(MIN)}$ = 1.20V, $I_Q$ = 100µA, $I_{SD}$ < 1µA, TSSOP16E Package
LT1767	25V, 1.2A ( $I_{OUT}$ ), 1.1MHz, High Efficiency Step-Down DC/DC Converter	$V_{IN}$ : 3.0V to 25V, $V_{OUT(MIN)}$ = 1.20V, $I_Q$ = 1mA, $I_{SD}$ < 6µA, MS8E Package
LT1940	Dual 25V, 1.4A ( $I_{OUT}$ ), 1.1MHz, High Efficiency Step-Down DC/DC Converter	$V_{IN}$ : 3.6V to 25V, $V_{OUT(MIN)}$ = 1.20V, $I_Q$ = 3.8mA, $I_{SD}$ < 30µA, TSSOP16E Package
LT1766	60V, 1.2A ( $I_{OUT}$ ), 200kHz, High Efficiency Step-Down DC/DC Converter	$V_{IN}$ : 5.5V to 60V, $V_{OUT(MIN)}$ = 1.20V, $I_Q$ = 2.5mA, $I_{SD}$ = 25µA, TSSOP16E Package
LT3434/LT3435	60V, 2.4A ( $I_{OUT}$ ), 200/500kHz, High Efficiency Step-Down DC/DC Converter with Burst Mode Operation	$V_{IN}$ : 3.3V to 60V, $V_{OUT(MIN)}$ = 1.20V, $I_Q$ = 100µA, $I_{SD}$ < 1µA, TSSOP16E Package

ThinSOT is a trademark of Linear Technology Corporation.



## X-ON Electronics

Largest Supplier of Electrical and Electronic Components

*Click to view similar products for [Switching Voltage Regulators](#) category:*

*Click to view products by [Analog Devices](#) manufacturer:*

Other Similar products are found below :

[TLF30682QVS01XUMA1](#) [TPSM84209RKHR](#) [FAN53526UC106X](#) [FAN53526UC128X](#) [MP1587EN-LF](#) [FAN48610BUC33X](#)  
[FAN48617UC50X](#) [FAN53526UC89X](#) [MIC45116-1YMP-T1](#) [NCV891234MW50R2G](#) [AST1S31PUR](#) [16017](#) [A6986FTR](#) [NCP81103MNTXG](#)  
[NCP81203PMNTXG](#) [MAX17242ETPA+](#) [MAX16935RATEB/V+](#) [MP2313GJ-Z](#) [NCP81208MNTXG](#) [MP8759GD-Z](#) [FAN53526UC100X](#)  
[FAN53526UC84X](#) [PCA9412AUKZ](#) [MP2314SGJ-Z](#) [AS1340A-BTDM-10](#) [MP3421GG-P](#) [NCP81109GMNTXG](#) [MP6003DN-LF-Z](#)  
[MAX16935BAUES/V+](#) [LT8315IFE#PBF](#) [SCY1751FCCT1G](#) [NCP81109JMNTXG](#) [MAX16956AUBA/V+](#) [AP3409ADNTR-G1](#)  
[FAN48623UC36FX](#) [MPQ2454GH](#) [MPQ2454GH-AEC1](#) [MP21148GQD-P](#) [AS3701B-BWLM-68](#) [MPQ2143DJ-P](#) [MP9942AGJ-P](#)  
[MP8759GD-P](#) [MP5610GQG-P](#) [MP28200GG-P](#) [MP2451DJ-LF-Z](#) [MP2326GD-P](#) [MP2314SGJ-P](#) [MP2158AGQH-P](#) [MP2148GQD-18-P](#)  
[MP1470HGJ-P](#)