

42V_{IN} Micropower No-Opto Isolated Flyback Converter with 65V/1.2A Switch

FEATURES

- 2.7V to 42V Input Voltage Range
- 1.2A, 65V Internal DMOS Power Switch
- Low Quiescent Current:
 - 100µA in Sleep Mode
 - 350µA in Active Mode
- Boundary Mode Operation at Heavy Load
- Low-Ripple Burst Mode® Operation at Light Load
- Minimum Load <0.5% (Typ) of Full Output
- V_{OUT} Set with a Single External Resistor
- No Transformer Third Winding or Opto-Isolator Required for Regulation
- Accurate EN/UVLO Threshold and Hysteresis
- Internal Compensation and Soft-Start
- Output Short-Circuit Protection
- 5-Lead TSOT-23 Package
- AEC-Q100 Qualified for Automotive Applications

APPLICATIONS

- Isolated Telecom, Automotive, Industrial, Medical Power Supplies
- Isolated Auxiliary/Housekeeping Power Supplies

DESCRIPTION

The **LT®8301** is a micropower isolated flyback converter. By sampling the isolated output voltage directly from the primary-side flyback waveform, the part requires no third winding or opto-isolator for regulation. The output voltage is programmed with a single external resistor. Internal compensation and soft-start further reduce external component count. Boundary mode operation provides a small magnetic solution with excellent load regulation. Low ripple Burst Mode operation maintains high efficiency at light load while minimizing the output voltage ripple. A 1.2A, 65V DMOS power switch is integrated along with all high voltage circuitry and control logic into a 5-lead ThinSOT™ package.

The LT8301 operates from an input voltage range of 2.7V to 42V and can deliver up to 6W of isolated output power. The high level of integration and the use of boundary and low ripple burst modes result in a simple to use, low component count, and high efficiency application solution for isolated power delivery.

All registered trademarks and trademarks are the property of their respective owners. Protected by U.S. Patents, including 5438499, 7463497, and 7471522.

TYPICAL APPLICATION

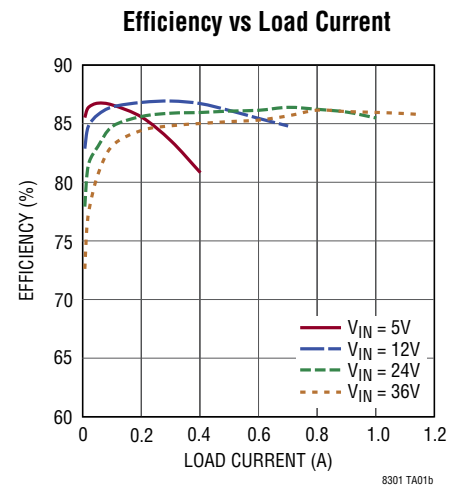
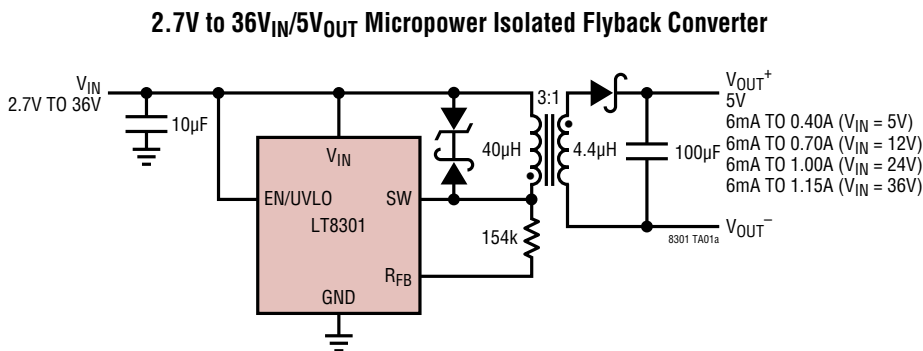

LT8301

ABSOLUTE MAXIMUM RATINGS

(Note 1)

SW (Note 2)	65V
V_{IN}	42V
EN/UVLO	V_{IN}
R_{FB}	$V_{IN} - 0.5V$ to V_{IN}
Current into R_{FB}	200 μ A
Operating Junction Temperature Range (Notes 3, 4)	
LT8301E, LT8301I	-40°C to 125°C
LT8301J, LT8301H	-40°C to 150°C
LT8301MP	-55°C to 150°C
Storage Temperature Range	-65°C to 150°C

PIN CONFIGURATION

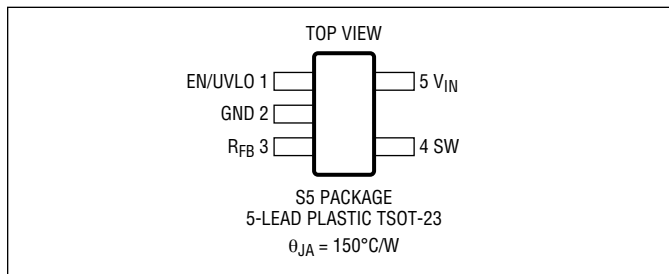

ORDER INFORMATION

LEAD FREE FINISH	TAPE AND REEL	PART MARKING*	PACKAGE DESCRIPTION	TEMPERATURE RANGE
LT8301ES5#TRMPBF	LT8301ES5#TRPBF	LTGMF	5-Lead Plastic TSOT-23	-40°C to 125°C
LT8301IS5#TRMPBF	LT8301IS5#TRPBF	LTGMF	5-Lead Plastic TSOT-23	-40°C to 125°C
LT8301JS5#TRMPBF	LT8301JS5#TRPBF	LTGMF	5-Lead Plastic TSOT-23	-40°C to 150°C
LT8301HS5#TRMPBF	LT8301HS5#TRPBF	LTGMF	5-Lead Plastic TSOT-23	-40°C to 150°C
LT8301MPS5#TRMPBF	LT8301MPS5#TRPBF	LTGMF	5-Lead Plastic TSOT-23	-55°C to 150°C

AUTOMOTIVE PRODUCTS**

LT8301ES5#WTRMPBF	LT8301ES5#WTRPBF	LTGMF	5-Lead Plastic TSOT-23	-40°C to 125°C
LT8301IS5#WTRMPBF	LT8301IS5#WTRPBF	LTGMF	5-Lead Plastic TSOT-23	-40°C to 125°C
LT8301JS5#WTRMPBF	LT8301JS5#WTRPBF	LTGMF	5-Lead Plastic TSOT-23	-40°C to 150°C
LT8301HS5#WTRMPBF	LT8301HS5#WTRPBF	LTGMF	5-Lead Plastic TSOT-23	-40°C to 150°C

Contact the factory for parts specified with wider operating temperature ranges. *The temperature grade is identified by a label on the shipping container.

Tape and reel specifications. Some packages are available in 500 unit reels through designated sales channels with #TRMPBF suffix.

**Versions of this part are available with controlled manufacturing to support the quality and reliability requirements of automotive applications. These models are designated with a #W suffix. Only the automotive grade products shown are available for use in automotive applications. Contact your local Analog Devices account representative for specific product ordering information and to obtain the specific Automotive Reliability reports for these models.

ELECTRICAL CHARACTERISTICS The ● denotes the specifications which apply over the full operating temperature range, otherwise specifications are at $T_A = 25^\circ\text{C}$. $V_{IN} = 5\text{V}$, $V_{EN/UVLO} = V_{IN}$ unless otherwise noted.

SYMBOL	PARAMETER	CONDITIONS	MIN	TYP	MAX	UNIT
V_{IN}	Input Voltage Range		● 2.7		42	V
	V_{IN} UVLO Threshold	Rising Falling		2.5 2.3	2.65	V V
I_Q	V_{IN} Quiescent Current	$V_{EN/UVLO} = 0.2\text{V}$		0.8	2	μA
		$V_{EN/UVLO} = 1.1\text{V}$		215		μA
		Sleep Mode (Switch Off)		100		μA
		Active Mode (Switch On)		350		μA
	EN/UVLO Shutdown Threshold	For Lowest Off I_Q	● 0.2	0.55		V
	EN/UVLO Enable Threshold	Falling Hysteresis	1.204	1.228 0.014	1.248	V V
I_{HYS}	EN/UVLO Hysteresis Current	$V_{EN/UVLO} = 0.2\text{V}$	-0.1	0	0.1	μA
		$V_{EN/UVLO} = 1.1\text{V}$	2.2	2.5	2.8	μA
		$V_{EN/UVLO} = 1.3\text{V}$	-0.1	0	0.1	μA
f_{MIN}	Minimum Switching Frequency		9.4	10	10.6	kHz
$t_{ON(MIN)}$	Minimum Switch-On Time			170		ns
$t_{OFF(MAX)}$	Maximum Switch-Off Time	Backup Timer		190		μs
$I_{SW(MAX)}$	Maximum SW Current Limit		● 1.200	1.375	1.550	A
$I_{SW(MIN)}$	Minimum SW Current Limit		● 0.22	0.29	0.36	A
$R_{DS(ON)}$	Switch On-Resistance	$I_{SW} = 500\text{mA}$		0.4		Ω
I_{LKG}	Switch Leakage Current	$V_{IN} = 42\text{V}$, $V_{SW} = 65\text{V}$		0.1	0.5	μA
I_{RFB}	R_{FB} Regulation Current		● 97.5	100	102.5	μA
	R_{FB} Regulation Current Line Regulation	$2.7\text{V} \leq V_{IN} \leq 42\text{V}$		0.02	0.1	%/V

Note 1: Stresses beyond those listed under Absolute Maximum Ratings may cause permanent damage to the device. Exposure to any Absolute Maximum Rating condition for extended periods may affect device reliability and lifetime.

Note 2: The SW pin is rated to 65V for transients. Depending on the leakage inductance voltage spike, operating waveforms of the SW pin should be derated to keep the flyback voltage spike below 65V as shown in Figure 5.

Note 3: The LT8301E is guaranteed to meet performance specifications from 0°C to 125°C operating junction temperature. Specifications over the -40°C to 125°C operating junction temperature range are assured by design, characterization and correlation with statistical process controls.

The LT8301I is guaranteed over the full -40°C to 125°C operating junction temperature range. The LT8301J and LT8301H are guaranteed over the full -40°C to 150°C operating junction temperature range. The LT8301MP is guaranteed over the full -55°C to 150°C operating junction temperature range. High junction temperatures degrade operating lifetimes. Operating lifetime is derated at junction temperature greater than 125°C.

Note 4: The LT8301 includes overtemperature protection that is intended to protect the device during momentary overload conditions. Junction temperature will exceed 150°C when overtemperature protection is active. Continuous operation above the specified maximum operating junction temperature may impair device reliability.

TYPICAL PERFORMANCE CHARACTERISTICS $T_A = 25^\circ\text{C}$, unless otherwise noted.

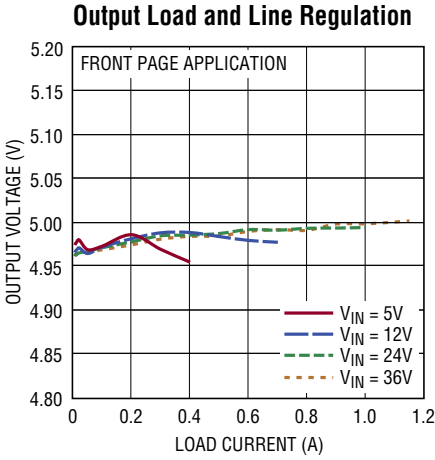

8301 G01

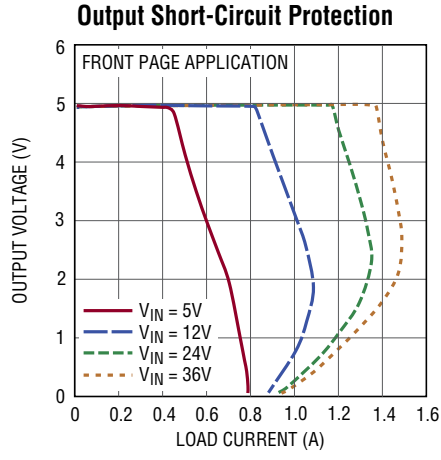

8301 G02

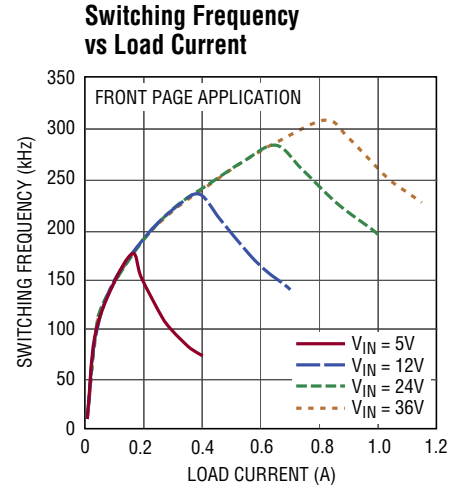

8301 G03

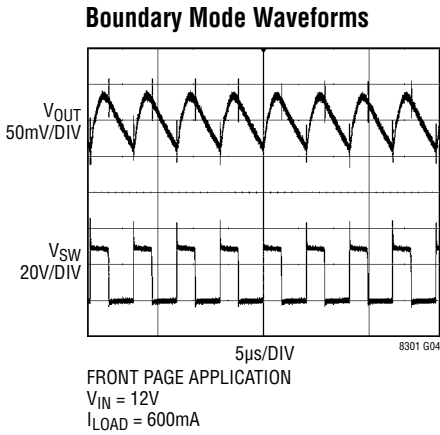

8301 G04

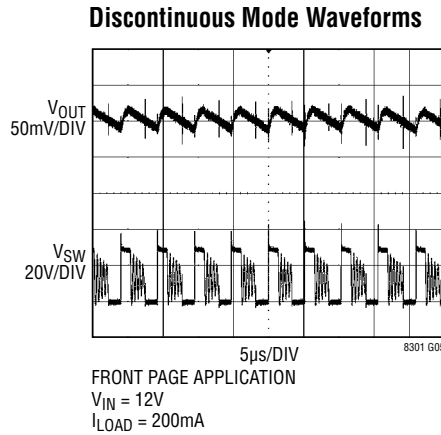

8301 G05

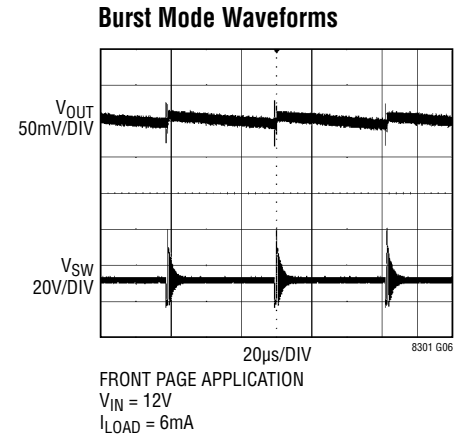

8301 G06

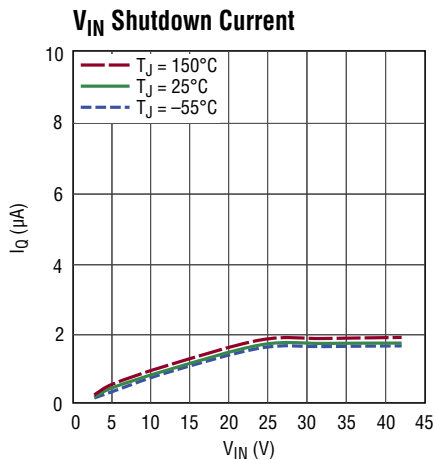

8301 G07

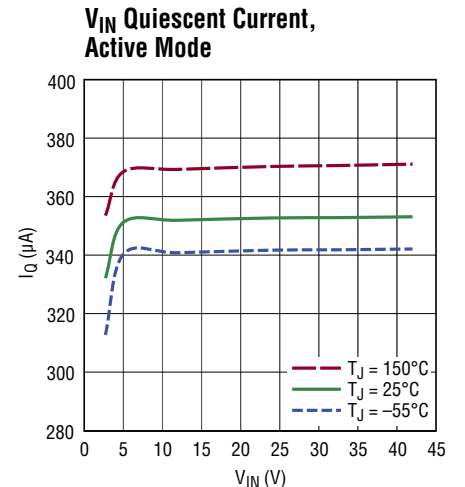
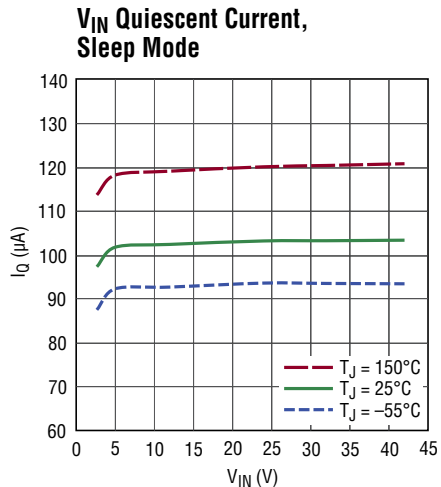

8301 G08

TYPICAL PERFORMANCE CHARACTERISTICS $T_A = 25^\circ\text{C}$, unless otherwise noted.

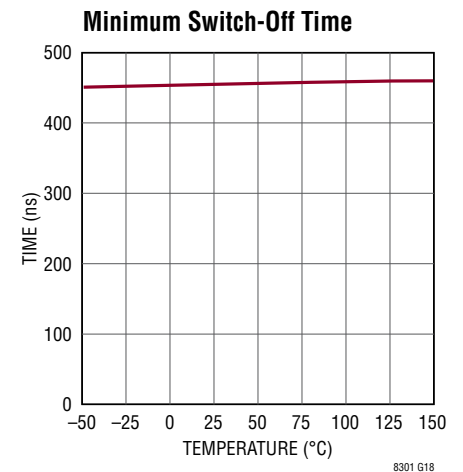
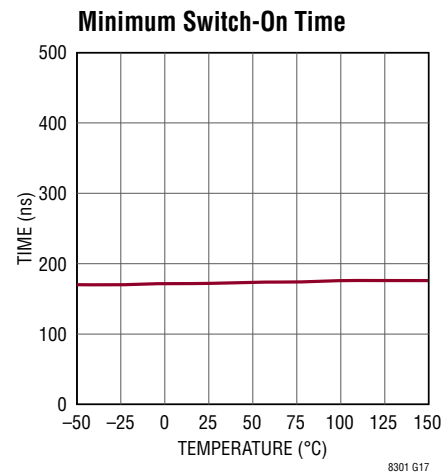
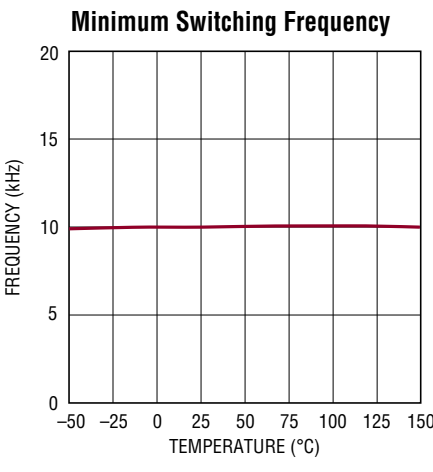
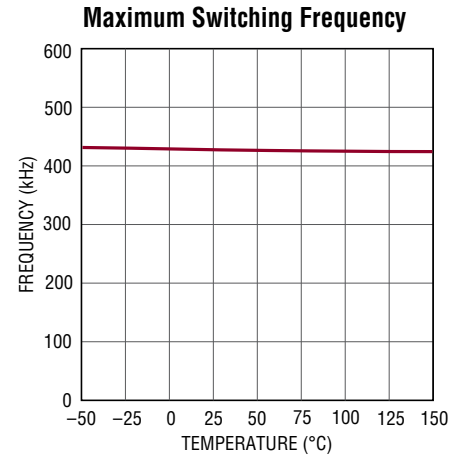
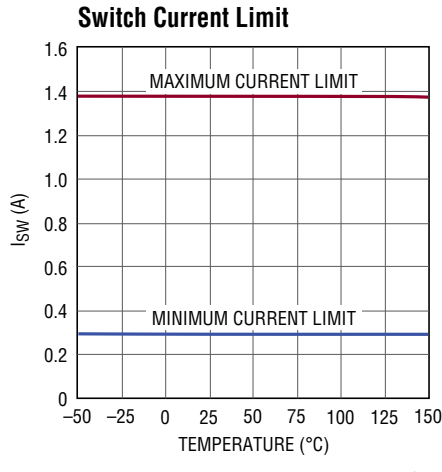
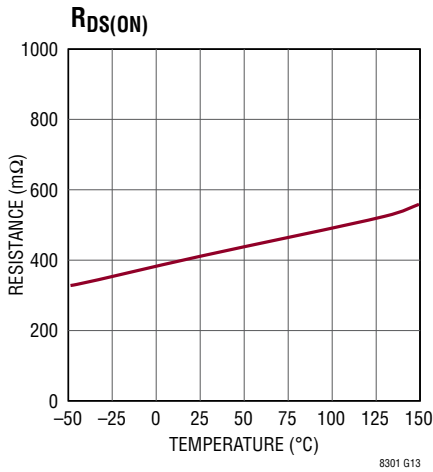
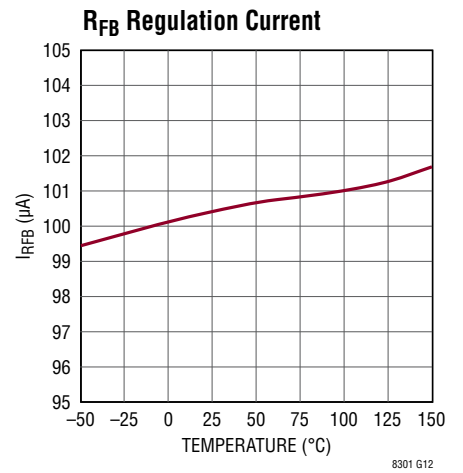
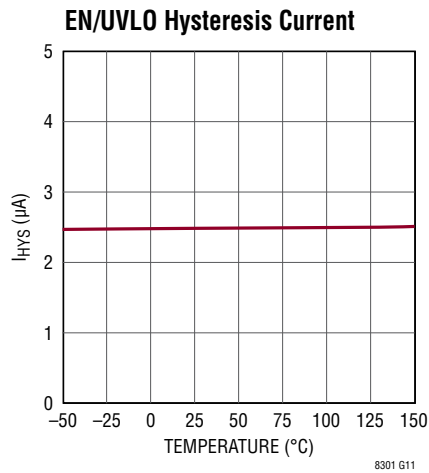
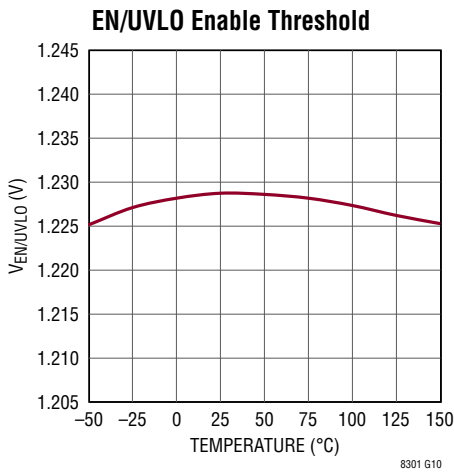

PIN FUNCTIONS

EN/UVLO (Pin 1): Enable/Undervoltage Lockout. The EN/UVLO pin is used to enable the LT8301. Pull the pin below 0.2V to shut down the LT8301. This pin has an accurate 1.228V threshold and can be used to program a V_{IN} undervoltage lockout (UVLO) threshold using a resistor divider from V_{IN} to ground. A 2.5 μ A current hysteresis allows the programming of V_{IN} UVLO hysteresis. If neither function is used, tie this pin directly to V_{IN} .

GND (Pin 2): Ground. Tie this pin directly to local ground plane.

R_{FB} (Pin 3): Input Pin for External Feedback Resistor. Connect a resistor from this pin to the transformer primary

SW pin. The ratio of the R_{FB} resistor to an internal 10k resistor, times a trimmed 1.0V reference voltage, determines the output voltage (plus the effect of any non-unity transformer turns ratio). Minimize trace area at this pin.

SW (Pin 4): Drain of the 65V Internal DMOS Power Switch. Minimize trace area at this pin to reduce EMI and voltage spikes.

V_{IN} (Pin 5): Input Supply. The V_{IN} pin supplies current to internal circuitry and serves as a reference voltage for the feedback circuitry connected to the R_{FB} pin. Locally bypass this pin to ground with a capacitor.

BLOCK DIAGRAM

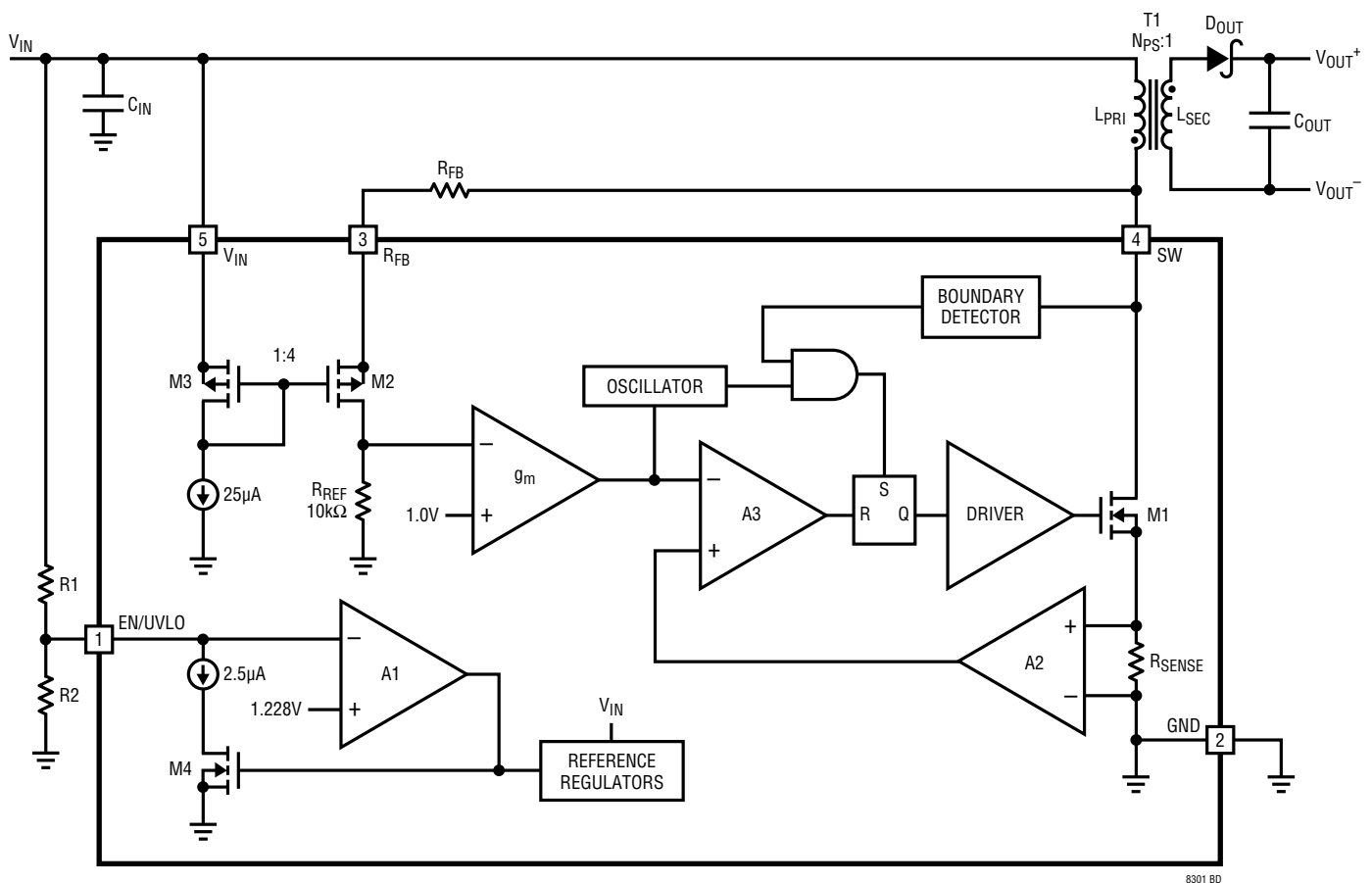

OPERATION

The LT8301 is a current mode switching regulator IC designed specially for the isolated flyback topology. The key problem in isolated topologies is how to communicate the output voltage information from the isolated secondary side of the transformer to the primary side for regulation. Historically, opto-isolators or extra transformer windings communicate this information across the isolation boundary. Opto-isolator circuits waste output power, and the extra components increase the cost and physical size of the power supply. Opto-isolators can also cause system issues due to limited dynamic response, nonlinearity, unit-to-unit variation and aging over lifetime. Circuits employing extra transformer windings also exhibit deficiencies, as using an extra winding adds to the transformer's physical size and cost, and dynamic response is often mediocre.

The LT8301 samples the isolated output voltage through the primary-side flyback pulse waveform. In this manner, neither opto-isolator nor extra transformer winding is required for regulation. Since the LT8301 operates in either boundary conduction mode or discontinuous conduction mode, the output voltage is always sampled on the SW pin when the secondary current is zero. This method improves load regulation without the need of external load compensation components.

The LT8301 is a simple to use micropower isolated flyback converter housed in a 5-lead TSOT-23 package. The output voltage is programmed with a single external resistor. By integrating the loop compensation and soft-start inside, the part further reduces the number of external components. As shown in the Block Diagram, many of the blocks are similar to those found in traditional switching regulators including reference, regulators, oscillator, logic, current amplifier, current comparator, driver, and power switch. The novel sections include a flyback pulse sense circuit, a sample-and-hold error amplifier, and a boundary mode detector, as well as the additional logic for boundary conduction mode, discontinuous conduction mode, and low ripple Burst Mode operation.

Boundary Conduction Mode Operation

The LT8301 features boundary conduction mode operation at heavy load, where the chip turns on the primary power switch when the secondary current is zero. Boundary conduction mode is a variable frequency, variable peak-current switching scheme. The power switch turns on and the transformer primary current increases until an internally controlled peak current limit. After the power switch turns off, the voltage on the SW pin rises to the output voltage multiplied by the primary-to-secondary transformer turns ratio plus the input voltage. When the secondary current through the output diode falls to zero, the SW pin voltage collapses and rings around V_{IN} . A boundary mode detector senses this event and turns the power switch back on.

Boundary conduction mode returns the secondary current to zero every cycle, so parasitic resistive voltage drops do not cause load regulation errors. Boundary conduction mode also allows the use of smaller transformers compared to continuous conduction mode and does not exhibit sub-harmonic oscillation.

Discontinuous Conduction Mode Operation

As the load gets lighter, boundary conduction mode increases the switching frequency and decreases the switch peak current at the same ratio. Running at a higher switching frequency up to several MHz increases switching and gate charge losses. To avoid this scenario, the LT8301 has an additional internal oscillator, which clamps the maximum switching frequency to be less than 430kHz (typ). Once the switching frequency hits the internal frequency clamp, the part starts to delay the switch turn-on and operates in discontinuous conduction mode.

Low Ripple Burst Mode Operation

Unlike traditional flyback converters, the LT8301 has to turn on and off at least for a minimum amount of time and with a minimum frequency to allow accurate sampling

OPERATION

of the output voltage. The inherent minimum switch current limit and minimum switch-off time are necessary to guarantee the correct operation of specific applications.

As the load gets very light, the LT8301 starts to fold back the switching frequency while keeping the minimum switch current limit. So the load current is able to decrease while still allowing minimum switch-off time for

the sample-and-hold error amplifier. Meanwhile, the part switches between sleep mode and active mode, thereby reducing the effective quiescent current to improve light load efficiency. In this condition, the LT8301 operates in low ripple Burst Mode. The 10kHz (typ) minimum switching frequency determines how often the output voltage is sampled and also the minimum load requirement.

APPLICATIONS INFORMATION

Output Voltage

The R_{FB} resistor as depicted in the Block Diagram is the only external resistor used to program the output voltage. The LT8301 operates similar to traditional current mode switchers, except in the use of a unique flyback pulse sense circuit and a sample-and-hold error amplifier, which sample and therefore regulate the isolated output voltage from the flyback pulse.

Operation is as follows: when the power switch M1 turns off, the SW pin voltage rises above the V_{IN} supply. The amplitude of the flyback pulse, i.e., the difference between the SW pin voltage and V_{IN} supply, is given as:

$$V_{FLBK} = (V_{OUT} + V_F + I_{SEC} \cdot ESR) \cdot N_{PS}$$

$$V_F = \text{Output diode forward voltage}$$

$$I_{SEC} = \text{Transformer secondary current}$$

$$ESR = \text{Total impedance of secondary circuit}$$

$$N_{PS} = \text{Transformer effective primary-to-secondary turns ratio}$$

The flyback voltage is then converted to a current I_{RFB} by the flyback pulse sense circuit (M2 and M3). This current I_{RFB} also flows through the internal 10k R_{REF} resistor to generate a ground-referred voltage. The resulting voltage feeds to the inverting input of the sample-and-hold error amplifier. Since the sample-and-hold error amplifier samples the voltage when the secondary current is zero, the $(I_{SEC} \cdot ESR)$ term in the V_{FLBK} equation can be assumed to be zero.

An internal trimmed reference voltage, V_{IREF} 1.0V, feeds to the non-inverting input of the sample-and-hold error amplifier. The relatively high gain in the overall loop causes the voltage across R_{REF} resistor to be nearly equal to V_{IREF} . The resulting relationship between V_{FLBK} and V_{IREF} can be expressed as:

$$\left(\frac{V_{FLBK}}{R_{FB}} \right) \cdot R_{REF} = V_{IREF}$$

or

$$V_{FLBK} = \left(\frac{V_{IREF}}{R_{REF}} \right) \cdot R_{FB} = I_{RFB} \cdot R_{FB}$$

V_{IREF} = Internal trimmed reference voltage

$I_{RFB} = R_{FB}$ regulation current = 100 μ A

Combination with the previous V_{FLBK} equation yields an equation for V_{OUT} , in terms of the R_{FB} resistor, transformer turns ratio, and diode forward voltage:

$$V_{OUT} = 100\mu\text{A} \cdot \left(\frac{R_{FB}}{N_{PS}} \right) - V_F$$

Output Temperature Coefficient

The first term in the V_{OUT} equation does not have temperature dependence, but the output diode forward voltage V_F has a significant negative temperature coefficient ($-1\text{mV}/^\circ\text{C}$ to $-2\text{mV}/^\circ\text{C}$). Such a negative temperature coefficient produces approximately 200mV to 300mV voltage variation on the output voltage across temperature.

APPLICATIONS INFORMATION

For higher voltage outputs, such as 12V and 24V, the output diode temperature coefficient has a negligible effect on the output voltage regulation. For lower voltage outputs, such as 3.3V and 5V, however, the output diode temperature coefficient does count for an extra 2% to 5% output voltage regulation. For customers requiring tight output voltage regulation across temperature, please refer to other ADI parts with integrated temperature compensation features.

Selecting Actual R_{FB} Resistor Value

The LT8301 uses a unique sampling scheme to regulate the isolated output voltage. Due to the sampling nature, the scheme contains repeatable delays and error sources, which will affect the output voltage and force a re-evaluation of the R_{FB} resistor value. Therefore, a simple two-step process is required to choose feedback resistor R_{FB} .

Rearrangement of the expression for V_{OUT} in the Output Voltage section yields the starting value for R_{FB} :

$$R_{FB} = \frac{N_{PS} \cdot (V_{OUT} + V_F)}{100\mu A}$$

V_{OUT} = Output voltage

V_F = Output diode forward voltage = $\sim 0.3V$

N_{PS} = Transformer effective primary-to-secondary turns ratio

Power up the application with the starting R_{FB} value and other components connected, and measure the regulated output voltage, $V_{OUT(MEAS)}$. The final R_{FB} value can be adjusted to:

$$R_{FB(FINAL)} = \frac{V_{OUT}}{V_{OUT(MEAS)}} \cdot R_{FB}$$

Once the final R_{FB} value is selected, the regulation accuracy from board to board for a given application will be very consistent, typically under $\pm 5\%$ when including device variation of all the components in the system (assuming resistor tolerances and transformer windings matching within $\pm 1\%$). However, if the transformer or the output diode is changed, or the layout is dramatically altered, there may be some change in V_{OUT} .

Output Power

A flyback converter has a complicated relationship between the input and output currents compared to a buck or a boost converter. A boost converter has a relatively constant maximum input current regardless of input voltage and a buck converter has a relatively constant maximum output current regardless of input voltage. This is due to the continuous non-switching behavior of the two currents. A flyback converter has both discontinuous input and output currents which make it similar to a non-isolated buck-boost converter. The duty cycle will affect the input and output currents, making it hard to predict output power. In addition, the winding ratio can be changed to multiply the output current at the expense of a higher switch voltage.

The graphs in Figures 1 to 4 show the typical maximum output power possible for the output voltages 3.3V, 5V, 12V, and 24V. The maximum output power curve is the calculated output power if the switch voltage is 50V during the switch-off time. 15V of margin is left for leakage inductance voltage spike. To achieve this power level at a given input, a winding ratio value must be calculated to stress the switch to 50V, resulting in some odd ratio values. The curves below the maximum output power curve are examples of common winding ratio values and the amount of output power at given input voltages.

One design example would be a 5V output converter with a minimum input voltage of 8V and a maximum input voltage of 32V. A three-to-one winding ratio fits this design example perfectly and outputs equal to 5.42W at 32V but lowers to 2.71W at 8V.

The following equations calculate output power:

$$P_{OUT} = \eta \cdot V_{IN} \cdot D \cdot I_{SW(MAX)} \cdot 0.5$$

$$\eta = \text{Efficiency} = \sim 85\%$$

$$D = \text{Duty Cycle} = \frac{(V_{OUT} + V_F) \cdot N_{PS}}{(V_{OUT} + V_F) \cdot N_{PS} + V_{IN}}$$

$$I_{SW(MAX)} = \text{Maximum switch current limit} = 1.2A \text{ (min)}$$

APPLICATIONS INFORMATION

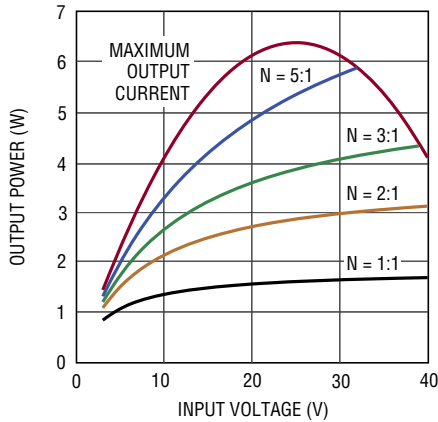

Figure 1. Output Power for 3.3V Output

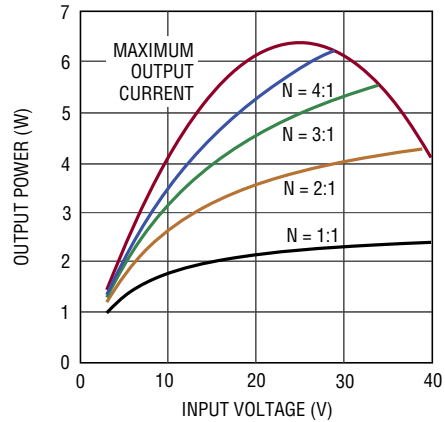

Figure 2. Output Power for 5V Output

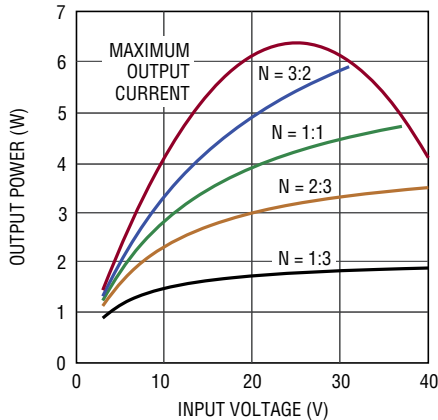

Figure 3. Output Power for 12V Output

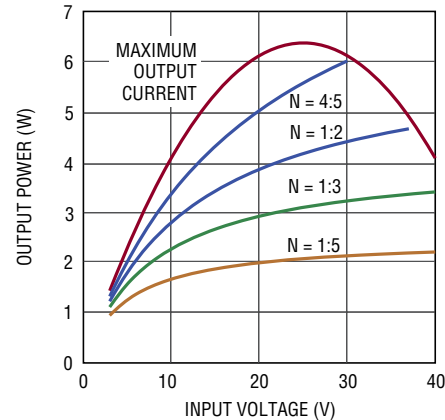

Figure 4. Output Power for 24V Output

Primary Inductance Requirement

The LT8301 obtains output voltage information from the reflected output voltage on the SW pin. The conduction of secondary current reflects the output voltage on the primary SW pin. The sample-and-hold error amplifier needs a minimum 450ns to settle and sample the reflected output voltage. In order to ensure proper sampling, the secondary winding needs to conduct current for a minimum of 450ns. The following equation gives the minimum value for primary-side magnetizing inductance:

$$L_{PRI} \geq \frac{t_{OFF(MIN)} \cdot N_{PS} \cdot (V_{OUT} + V_F)}{I_{SW(MIN)}}$$

$t_{OFF(MIN)}$ = Minimum switch-off time = 450ns

$I_{SW(MIN)}$ = Minimum switch current limit = 290mA (typ)

In addition to the primary inductance requirement for the minimum switch-off time, the LT8301 has minimum switch-on time that prevents the chip from turning on the power switch shorter than approximately 170ns. This minimum switch-on time is mainly for leading-edge blanking the initial switch turn-on current spike. If the inductor current exceeds the desired current limit during that time, oscillation may occur at the output as the current control loop will lose its ability to regulate. Therefore, the following equation relating to maximum input voltage must also be followed in selecting primary-side magnetizing inductance:

$$L_{PRI} \geq \frac{t_{ON(MIN)} \cdot V_{IN(MAX)}}{I_{SW(MIN)}}$$

$t_{ON(MIN)}$ = Minimum switch-on time = 170ns

APPLICATIONS INFORMATION

In general, choose a transformer with its primary magnetizing inductance about 30% larger than the minimum values calculated above. A transformer with much larger inductance will have a bigger physical size and may cause instability at light load.

Selecting a Transformer

Transformer specification and design is perhaps the most critical part of successfully applying the LT8301. In addition to the usual list of guidelines dealing with high frequency isolated power supply transformer design, the following information should be carefully considered.

Analog Devices has worked with several leading magnetic component manufacturers to produce pre-designed fly-back transformers for use with the LT8301. Table 1 shows the details of these transformers.

Turns Ratio

Note that when choosing the R_{FB} resistor to set output voltage, the user has relative freedom in selecting a transformer turns ratio to suit a given application. In contrast, the use of simple ratios of small integers, e.g., 3:1, 2:1, 1:1, provides more freedom in settling total turns and mutual inductance.

Table 1. Pre-designed Transformers—Typical Specifications

TRANSFORMER PART NUMBER	DIMENSIONS (W × L × H) (mm)	L _{PRI} (μH)	L _{LKG} (μH)	NP:NS	R _{PRI} (mΩ)	R _{SEC} (mΩ)	VENDOR	TARGET APPLICATIONS		
								V _{IN} (V)	V _{OUT} (V)	I _{OUT} (A)
750313973	15.24 × 13.34 × 11.43	40	1	4:1	80	40	Würth Elektronik	8 to 36	3.3	0.80
750370047	13.35 × 10.8 × 9.14	30	1	3:1:1	60	12.5	Würth Elektronik	8 to 32	5	0.55
750313974	15.24 × 13.34 × 11.43	40	1	3:1	80	50	Würth Elektronik	8 to 36	5	0.55
750313970	15.24 × 13.34 × 11.43	40	1	2:1	80	70	Würth Elektronik	18 to 42	3.3	0.75
750310799	9.14 × 9.78 × 10.54	25	0.125	1:1:0.33	60	74	Würth Elektronik	8 to 30	12	0.22
750313972	15.24 × 13.34 × 11.43	40	1	1:1	80	185	Würth Elektronik	18 to 42	5	0.42
750313975	15.24 × 13.34 × 11.43	40	1	1:2	110	865	Würth Elektronik	8 to 36	24	0.12
750313976	15.24 × 13.34 × 11.43	40	1	1:4	110	2300	Würth Elektronik	8 to 32	48	0.05
12387-T036	15.5 × 12.5 × 11.5	40	2	4:1	160	25	Sumida	8 to 36	3.3	0.80
12387-T037	15.5 × 12.5 × 11.5	40	2	3:1	210	30	Sumida	8 to 36	5	0.55
12387-T040	15.5 × 12.5 × 11.5	40	1.5	2:1	210	50	Sumida	18 to 42	3.3	0.75
12387-T041	15.5 × 12.5 × 11.5	40	1.5	1:1	210	200	Sumida	18 to 42	5	0.42
12387-T038	15.5 × 12.5 × 11.5	40	2	1:2	220	460	Sumida	8 to 36	24	0.12
12387-T039	15.5 × 12.5 × 11.5	40	2	1:4	220	2200	Sumida	8 to 32	48	0.05
PA3948.003NL	15.24 × 13.08 × 11.45	40	1.45	4:1	210	26	Pulse Engineering	8 to 36	3.3	0.80
PA3948.004NL	15.24 × 13.08 × 11.45	40	1.95	3:1	220	29	Pulse Engineering	8 to 36	5	0.55
PA3948.001NL	15.24 × 13.08 × 11.45	40	1.45	2:1	410	70	Pulse Engineering	18 to 42	3.3	0.75
PA3948.002NL	15.24 × 13.08 × 11.45	40	1.45	1:1	405	235	Pulse Engineering	18 to 42	5	0.42
PA3948.005NL	15.24 × 13.08 × 11.45	40	1.60	1:2	220	1275	Pulse Engineering	8 to 36	24	0.12
PA3948.006NL	15.24 × 13.08 × 11.45	40	1.65	1:4	220	3350	Pulse Engineering	8 to 32	48	0.05

APPLICATIONS INFORMATION

Typically, choose the transformer turns ratio to maximize available output power. For low output voltages (3.3V or 5V), a larger N:1 turns ratio can be used with multiple primary windings relative to the secondary to maximize the transformer's current gain (and output power). However, remember that the SW pin sees a voltage that is equal to the maximum input supply voltage plus the output voltage multiplied by the turns ratio. In addition, leakage inductance will cause a voltage spike ($V_{LEAKAGE}$) on top of this reflected voltage. This total quantity needs to remain below the 65V absolute maximum rating of the SW pin to prevent breakdown of the internal power switch. Together these conditions place an upper limit on the turns ratio, N_{PS} , for a given application. Choose a turns ratio low enough to ensure:

$$N_{PS} < \frac{65V - V_{IN(MAX)} - V_{LEAKAGE}}{V_{OUT} + V_F}$$

For lower output power levels, choose a smaller N:1 turns ratio to alleviate the SW pin voltage stress. Although a 1:N turns ratio makes it possible to have very high output voltages without exceeding the breakdown voltage of the internal power switch, the multiplied parasitic capacitance through turns ratio may cause the switch turn-on current spike ringing beyond 170ns leading-edge blanking, thereby producing light load instability in certain applications. So any 1:N turns ratio should be fully evaluated before its use with the LT8301.

The turns ratio is an important element in the isolated feedback scheme, and directly affects the output voltage accuracy. Make sure the transformer manufacturer specifies turns ratio accuracy within $\pm 1\%$.

Saturation Current

The current in the transformer windings should not exceed its rated saturation current. Energy injected once the core is saturated will not be transferred to the secondary and will instead be dissipated in the core. When designing custom transformers to be used with the LT8301, the saturation current should always be specified by the transformer manufacturers.

Winding Resistance

Resistance in either the primary or secondary windings will reduce overall power efficiency. Good output voltage regulation will be maintained independent of winding resistance due to the boundary/discontinuous conduction mode operation of the LT8301.

Leakage Inductance and Snubbers

Transformer leakage inductance on either the primary or secondary causes a voltage spike to appear on the primary after the power switch turns off. This spike is increasingly prominent at higher load currents where more stored energy must be dissipated. It is very important to minimize transformer leakage inductance.

When designing an application, adequate margin should be kept for the worst-case leakage voltage spikes even under overload conditions. In most cases shown in Figure 5, the reflected output voltage on the primary plus V_{IN} should be kept below 50V. This leaves at least 15V margin for the leakage spike across line and load conditions. A larger voltage margin will be required for poorly wound transformers or for excessive leakage inductance.

In addition to the voltage spikes, the leakage inductance also causes the SW pin ringing for a while after the power switch turns off. To prevent the voltage ringing falsely triggering the boundary mode detector, the LT8301 internally blanks the boundary mode detector for approximately 350ns. Any remaining voltage ringing after 350ns may turn the power switch back on again before the secondary current falls to zero. So the leakage inductance spike ringing should be limited to less than 350ns.

APPLICATIONS INFORMATION

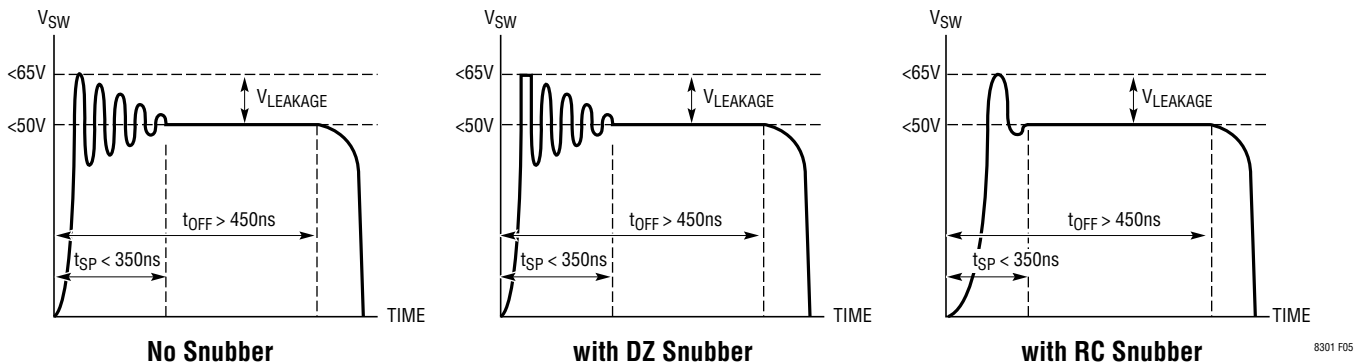

Figure 5. Maximum Voltages for SW Pin Flyback Waveform

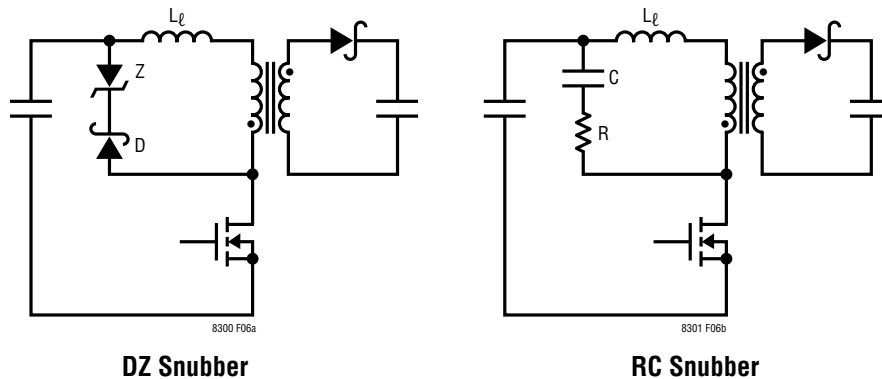

Figure 6. Snubber Circuits

A snubber circuit is recommended for most applications. Two types of snubber circuits shown in Figure 6 that can protect the internal power switch include the DZ (diode-Zener) snubber and the RC (resistor-capacitor) snubber. The DZ snubber ensures well defined and consistent clamping voltage and has slightly higher power efficiency, while the RC snubber quickly damps the voltage spike ringing and provides better load regulation and EMI performance. Figure 5 shows the flyback waveforms with the DZ and RC snubbers.

For the DZ snubber, proper care must be taken when choosing both the diode and the Zener diode. Schottky diodes are typically the best choice, but some PN diodes can be used if they turn on fast enough to limit the leakage inductance spike. Choose a diode that has a reverse-voltage rating higher than the maximum SW pin voltage. The

Zener diode breakdown voltage should be chosen to balance power loss and switch voltage protection. The best compromise is to choose the largest voltage breakdown. Use the following equation to make the proper choice:

$$V_{ZENER(MAX)} \leq 65V - V_{IN(MAX)}$$

For an application with a maximum input voltage of 32V, choose a 20V Zener diode, the $V_{ZENER(MAX)}$ of which is around 21V and below the 33V maximum.

The power loss in the clamp will determine the power rating of the Zener diode. Power loss in the clamp is highest at maximum load and minimum input voltage. The switch current is highest at this point along with the energy stored in the leakage inductance. A 0.25W Zener will satisfy most applications when the highest V_{ZENER} is chosen.

APPLICATIONS INFORMATION

Tables 2 and 3 show some recommended diodes and Zener diodes.

Table 2. Recommended Zener Diodes

PART	V _{ZENER} (V)	POWER (W)	CASE	VENDOR
CMDZ5248B	18	0.25	SOD-323	Central Semiconductor
CMDZ5250B	20	0.25	SOD-323	

Table 3. Recommended Diodes

PART	I _{MAX} (A)	V _{REVERSE} (V)	CASE	VENDOR
CMHD4448	0.25	100	SOD-123	Central Semiconductor
DFLS1100	1	100	PowerDI-123	Diodes Inc.
DFLS1150	1	150	PowerDI-123	Diodes Inc.

The recommended approach for designing an RC snubber is to measure the period of the ringing on the SW pin when the power switch turns off without the snubber and then add capacitance (starting with 100pF) until the period of the ringing is 1.5 to 2 times longer. The change in period will determine the value of the parasitic capacitance, from which the parasitic inductance can be determined from the initial period, as well. Once the value of the SW node capacitance and inductance is known, a series resistor can be added to the snubber capacitance to dissipate power and critically dampen the ringing. The equation for deriving the optimal series resistance using the observed periods (t_{PERIOD} and $t_{PERIOD(SNUBBED)}$) and snubber capacitance ($C_{SNUBBER}$) is:

$$C_{PAR} = \frac{C_{SNUBBER}}{\left(\frac{t_{PERIOD(SNUBBED)}}{t_{PERIOD}}\right)^2 - 1}$$

$$L_{PAR} = \frac{t_{PERIOD}^2}{C_{PAR} \cdot 4\pi^2}$$

$$R_{SNUBBER} = \sqrt{\frac{L_{PAR}}{C_{PAR}}}$$

Note that energy absorbed by the RC snubber will be converted to heat and will not be delivered to the load. In high voltage or high current applications, the snubber may need to be sized for thermal dissipation.

Undervoltage Lockout (UVLO)

A resistive divider from V_{IN} to the EN/UVLO pin implements undervoltage lockout (UVLO). The EN/UVLO pin falling threshold is set at 1.228V with 14mV hysteresis. In addition, the EN/UVLO pin sinks 2.5 μ A when the voltage at the pin is below 1.228V. This current provides user programmable hysteresis based on the value of R1. The programmable UVLO thresholds are:

$$V_{IN(UVLO+)} = \frac{1.242V \cdot (R1+R2)}{R2} + 2.5\mu A \cdot R1$$

$$V_{IN(UVLO-)} = \frac{1.228V \cdot (R1+R2)}{R2}$$

Figure 7 shows the implementation of external shutdown control while still using the UVLO function. The NMOS grounds the EN/UVLO pin when turned on, and puts the LT8301 in shutdown with quiescent current less than 2 μ A.

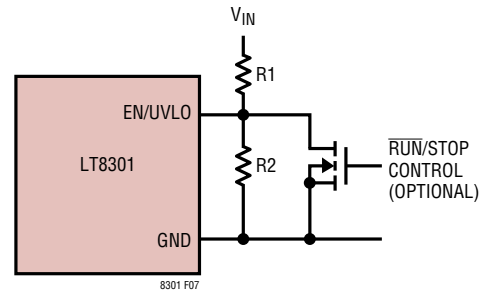

Figure 7. Undervoltage Lockout (UVLO)

APPLICATIONS INFORMATION

Minimum Load Requirement

The LT8301 samples the isolated output voltage from the primary-side flyback pulse waveform. The flyback pulse occurs once the primary switch turns off and the secondary winding conducts current. In order to sample the output voltage, the LT8301 has to turn on and off at least for a minimum amount of time and with a minimum frequency. The LT8301 delivers a minimum amount of energy even during light load conditions to ensure accurate output voltage information. The minimum energy delivery creates a minimum load requirement, which can be approximately estimated as:

$$I_{LOAD(MIN)} = \frac{L_{PRI} \cdot I_{SW(MIN)}^2 \cdot f_{MIN}}{2 \cdot V_{OUT}}$$

L_{PRI} = Transformer primary inductance

$I_{SW(MIN)}$ = Minimum switch current limit = 360mA (max)

f_{MIN} = Minimum switching frequency = 10.6kHz (max)

The LT8301 typically needs less than 0.5% of its full output power as minimum load. Alternatively, a Zener diode with its breakdown of 20% higher than the output voltage can serve as a minimum load if pre-loading is not acceptable. For a 5V output, use a 6V Zener with cathode connected to the output.

Output Short-Circuit Protection

When the output is heavily overloaded or shorted, the reflected SW pin waveform rings longer than the internal blanking time. If no protection scheme is applied, after the 450ns minimum switch-off time, the excessive ring might falsely trigger the boundary mode detector and turn the power switch back on again before the secondary current falls to zero. The part then runs into continuous conduction mode at maximum switching frequency, and the switch current may run away. To prevent the switch current from running away under this condition, the LT8301 gradually folds back both maximum switch current limit and switching frequency as the output voltage drops from regulation. As a result, the switch current remains below 1.375A (typ) maximum switch current limit. In the

worst-case scenario where the output is directly shorted to ground through a long wire and the huge ring after folding back still falsely triggers the boundary mode detector, a secondary overcurrent protection ensures that the LT8301 can still function properly. Once the switch current hits 2.2A overcurrent limit, a soft-start cycle initiates and throttles back both switch current limit and switching frequency very hard. This output short protection prevents the switch current from running away and limits the average output diode current.

Design Example

Use the following design example as a guide to design applications for the LT8301. The design example involves designing a 5V output with a 500mA load current and an input range from 8V to 32V.

$$V_{IN(MIN)} = 8V, V_{IN(NOM)} = 12V, V_{IN(MAX)} = 32V, \\ V_{OUT} = 5V, I_{OUT} = 500mA$$

Step 1: Select the Transformer Turns Ratio.

$$N_{PS} < \frac{65V - V_{IN(MAX)} - V_{LEAKAGE}}{V_{OUT} + V_F}$$

$V_{LEAKAGE}$ = Margin for transformer leakage spike = 15V

V_F = Output diode forward voltage = ~0.3V

Example:

$$N_{PS} < \frac{65V - 32V - 15V}{5V + 0.3V} = 3.4$$

The choice of transformer turns ratio is critical in determining output current capability of the converter. Table 4 shows the switch voltage stress and output current capability at different transformer turns ratio.

Table 4. Switch Voltage Stress and Output Current Capability vs Turns Ratio

N_{PS}	$V_{SW(MAX)}$ at $V_{IN(MAX)}$ (V)	$I_{OUT(MAX)}$ at $V_{IN(MIN)}$ (mA)	DUTY CYCLE (%)
1:1	37.3	330	14-40
2:1	42.6	470	25-57
3:1	47.9	540	33-67

Since only $N_{PS} = 3$ can meet the 500mA output current requirement, $N_{PS} = 3$ is chosen in this example.

APPLICATIONS INFORMATION

Step 2: Determine the Primary Inductance.

Primary inductance for the transformer must be set above a minimum value to satisfy the minimum switch-off and switch-on time requirements:

$$L_{PRI} \geq \frac{t_{OFF(MIN)} \cdot N_{PS} \cdot (V_{OUT} + V_F)}{I_{SW(MIN)}}$$

$$L_{PRI} \geq \frac{t_{ON(MIN)} \cdot V_{IN(MAX)}}{I_{SW(MIN)}}$$

$$t_{OFF(MIN)} = 450\text{ns}$$

$$t_{ON(MIN)} = 170\text{ns}$$

$$I_{SW(MIN)} = 290\text{mA (typ)}$$

Example:

$$L_{PRI} \geq \frac{450\text{ns} \cdot 3 \cdot (5\text{V} + 0.3\text{V})}{290\text{mA}} = 25\mu\text{H}$$

$$L_{PRI} \geq \frac{170\text{ns} \cdot 32\text{V}}{290\text{mA}} = 19\mu\text{H}$$

Most transformers specify primary inductance with a tolerance of $\pm 20\%$. With other component tolerance considered, choose a transformer with its primary inductance 30% larger than the minimum values calculated above. $L_{PRI} = 40\mu\text{H}$ is then chosen in this example.

Once the primary inductance has been determined, the maximum load switching frequency can be calculated as:

$$f_{SW} = \frac{1}{t_{ON} + t_{OFF}} = \frac{1}{\frac{L_{PRI} \cdot I_{SW}}{V_{IN}} + \frac{L_{PRI} \cdot I_{SW}}{N_{PS} \cdot (V_{OUT} + V_F)}}$$

$$I_{SW} = \frac{V_{OUT} \cdot I_{OUT} \cdot 2}{\eta \cdot V_{IN} \cdot D}$$

Example:

$$D = \frac{(5\text{V} + 0.3\text{V}) \cdot 3}{(5\text{V} + 0.3\text{V}) \cdot 3 + 12\text{V}} = 0.57$$

$$I_{SW} = \frac{5\text{V} \cdot 0.5\text{A} \cdot 2}{0.85 \cdot 12\text{V} \cdot 0.57} = 0.86\text{A}$$

$$f_{SW} = 199\text{kHz}$$

The transformer also needs to be rated for the correct saturation current level across line and load conditions. A saturation current rating larger than 2A is necessary to work with the LT8301. The 750313974 from Würth is chosen as the flyback transformer.

Step 3: Choose the Output Diode.

Two main criteria for choosing the output diode include forward current rating and reverse voltage rating. The maximum load requirement is a good first-order guess as the average current requirement for the output diode. A conservative metric is the maximum switch current limit multiplied by the turns ratio,

$$I_{DIODE(MAX)} = I_{SW(MAX)} \cdot N_{PS}$$

Example:

$$I_{DIODE(MAX)} = 4.125\text{A}$$

Next calculate reverse voltage requirement using maximum V_{IN} :

$$V_{REVERSE} = V_{OUT} + \frac{V_{IN(MAX)}}{N_{PS}}$$

Example:

$$V_{REVERSE} = 5\text{V} + \frac{32\text{V}}{3} = 15.6\text{V}$$

The CSMH5-20 (5A, 20V diode) from Central Semiconductor is chosen.

APPLICATIONS INFORMATION

Step 4: Choose the Output Capacitor.

The output capacitor should be chosen to minimize the output voltage ripple while considering the increase in size and cost of a larger capacitor. Use the equation below to calculate the output capacitance:

$$C_{OUT} = \frac{L_{PRI} \cdot I_{SW}^2}{2 \cdot V_{OUT} \cdot \Delta V_{OUT}}$$

Example:

Design for output voltage ripple less than 1% of V_{OUT} , i.e., 50mV.

$$C_{OUT} = \frac{40\mu\text{H} \cdot (0.86\text{A})^2}{2 \cdot 5\text{V} \cdot 0.05\text{V}} = 60\mu\text{F}$$

Remember ceramic capacitors lose capacitance with applied voltage. The capacitance can drop to 40% of quoted capacitance at the maximum voltage rating. So a 100 μF , 10V rating ceramic capacitor is chosen X5R or X7R type is recommended.

Step 5: Design Snubber Circuit.

The snubber circuit protects the power switch from leakage inductance voltage spike. A DZ snubber is recommended for this application because of lower leakage inductance and larger voltage margin. The Zener and the diode need to be selected.

The maximum Zener breakdown voltage is set according to the maximum V_{IN} :

$$V_{ZENER(MAX)} \leq 65\text{V} - V_{IN(MAX)}$$

Example:

$$V_{ZENER(MAX)} \leq 65\text{V} - 32\text{V} = 33\text{V}$$

A 20V Zener with a maximum of 21V will provide optimal protection and minimize power loss. So a 20V, 0.25W Zener from Central Semiconductor (CMDZ5250B) is chosen.

Choose a diode that is fast and has sufficient reverse voltage breakdown:

$$V_{REVERSE} > V_{SW(MAX)}$$

$$V_{SW(MAX)} = V_{IN(MAX)} + V_{ZENER(MAX)}$$

Example:

$$V_{REVERSE} > 53\text{V}$$

A 100V, 0.25A diode from Central Semiconductor (CMHD4448) is chosen.

Step 6: Select the R_{FB} Resistor.

Use the following equation to calculate the starting value for R_{FB} :

$$R_{FB} = \frac{N_{PS} \cdot (V_{OUT} + V_F)}{100\mu\text{A}}$$

Example:

$$R_{FB} = \frac{3 \cdot (5\text{V} + 0.3\text{V})}{100\mu\text{A}} = 159\text{k}$$

Depending on the tolerance of standard resistor values, the precise resistor value may not exist. For 1% standard values, a 158k resistor should be close enough. As discussed in the Application Information section, the final R_{FB} value should be adjusted on the measured output voltage.

APPLICATIONS INFORMATION

Step 7: Select the EN/UVLO Resistors.

Determine the amount of hysteresis required and calculate R1 resistor value:

$$V_{IN(HYS)} = 2.5\mu A \cdot R1$$

Example:

Choose 2V of hysteresis,

$$R1 = 806k$$

Determine the UVLO thresholds and calculate R2 resistor value:

$$V_{IN(UVLO+)} = \frac{1.242V \cdot (R1 + R2)}{R2} + 2.5\mu A \cdot R1$$

Example:

Set V_{IN} UVLO rising threshold to 7.5V,

$$R2 = 232k$$

$$V_{IN(UVLO+)} = 7.5V$$

$$V_{IN(UVLO-)} = 5.5V$$

Step 8: Ensure minimum load.

The theoretical minimum load can be approximately estimated as:

$$I_{LOAD(MIN)} = \frac{40\mu H \cdot (360mA)^2 \cdot 10.6kHz}{2 \cdot 5V} = 5.5mA$$

Remember to check the minimum load requirement in real application. The minimum load occurs at the point where the output voltage begins to climb up as the converter delivers more energy than what is consumed at the output. The real minimum load for this application is about 6mA. In this example, a 820Ω resistor is selected as the minimum load.

TYPICAL APPLICATIONS

2.7V to 36V_{IN}/15V_{OUT} Micropower Isolated Flyback Converter

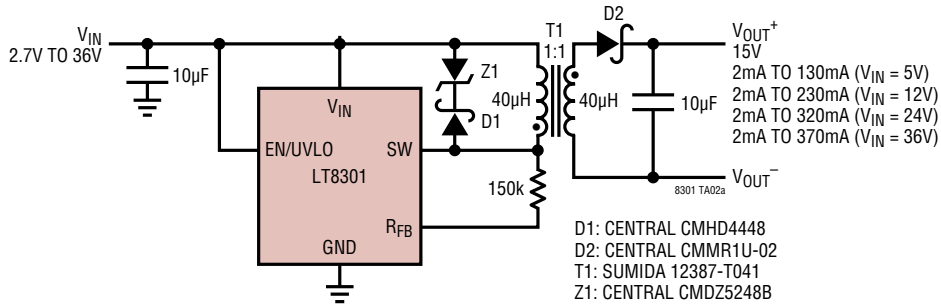

Efficiency vs Load Current

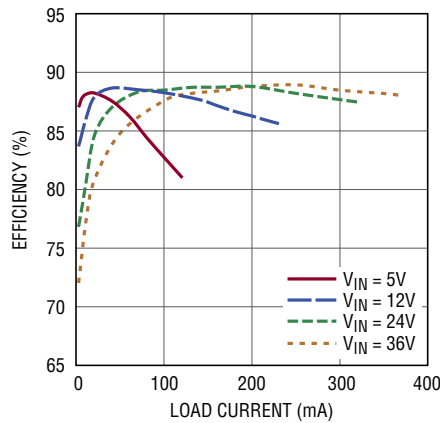

8301 TA02b

8V to 36V_{IN}/3.3V_{OUT} Micropower Isolated Flyback Converter

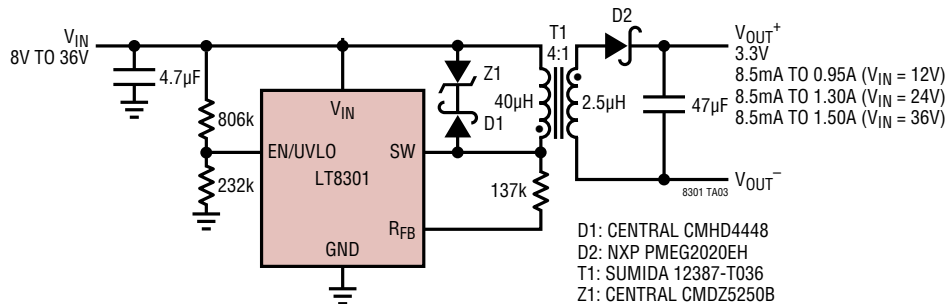

TYPICAL APPLICATIONS

8V to 36V_{IN}/24V_{OUT} Micropower Isolated Flyback Converter

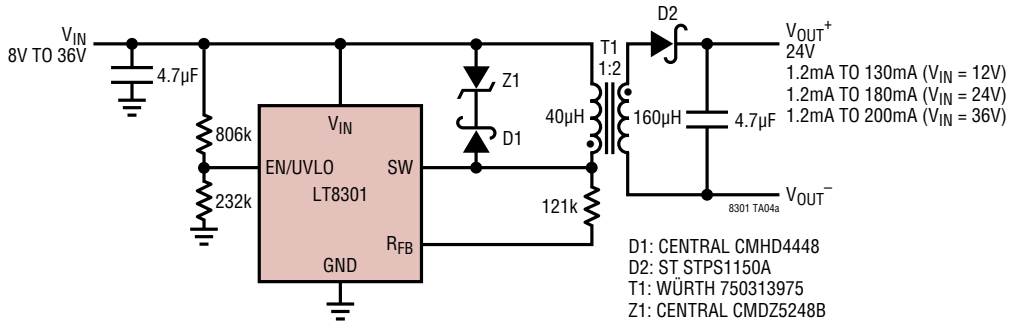

Efficiency vs Load Current

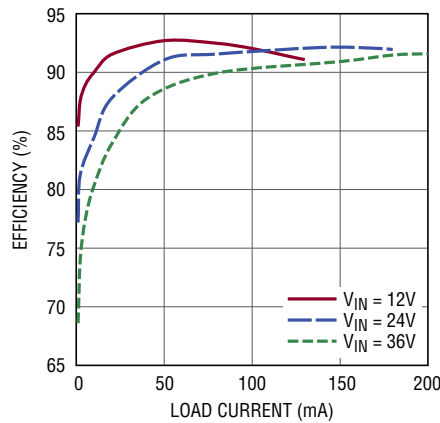

8V to 36V_{IN}/48V_{OUT} Micropower Isolated Flyback Converter

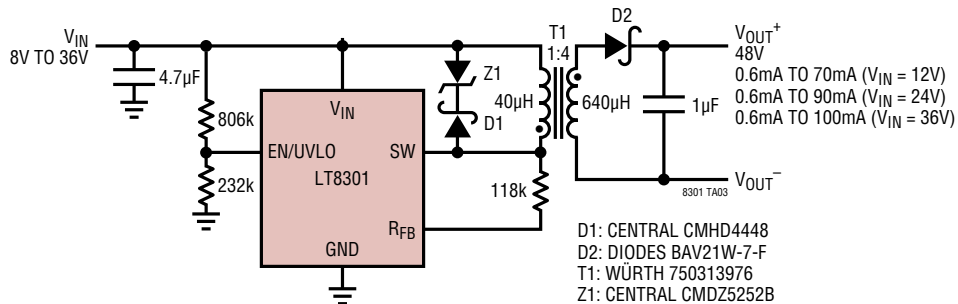

TYPICAL APPLICATIONS

V_{IN} to $(V_{IN} + 10V)/(V_{IN} - 10V)$ Micropower Converter

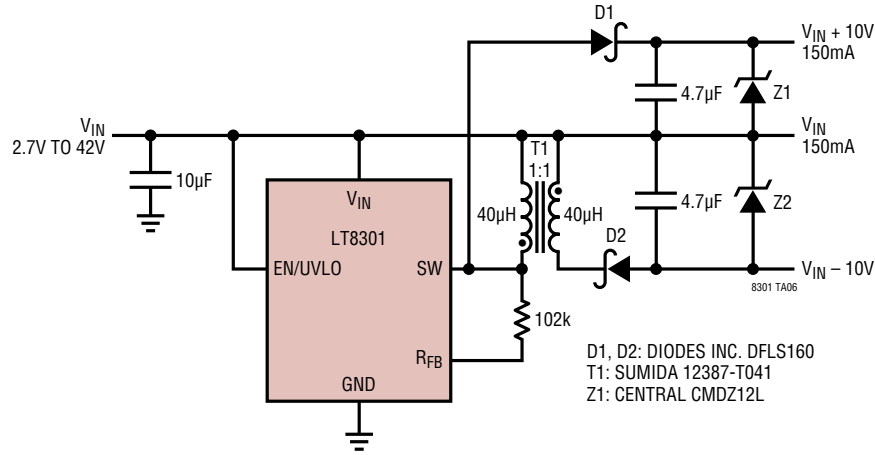

12V to 24V_{IN}/Four 15V_{OUT} Micropower Isolated Flyback Converter

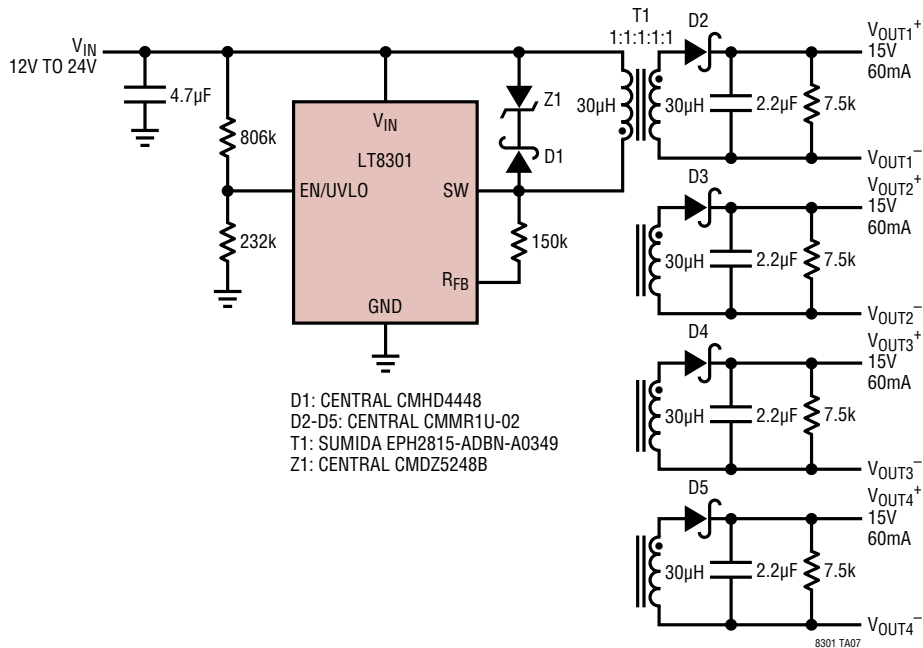

PACKAGE DESCRIPTION

S5 Package
5-Lead Plastic TSOT-23
 (Reference LTC DWG # 05-08-1635 Rev B)

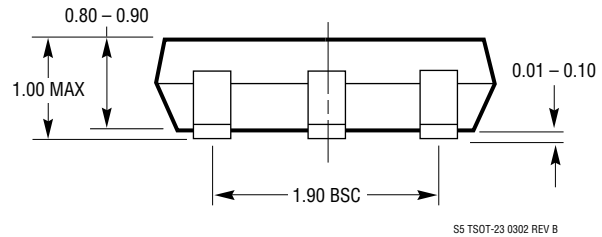
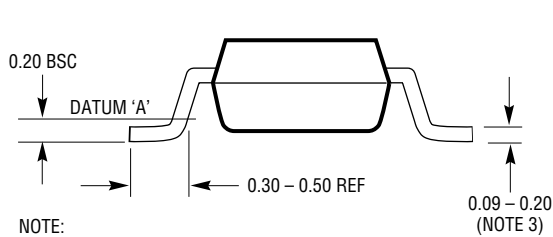
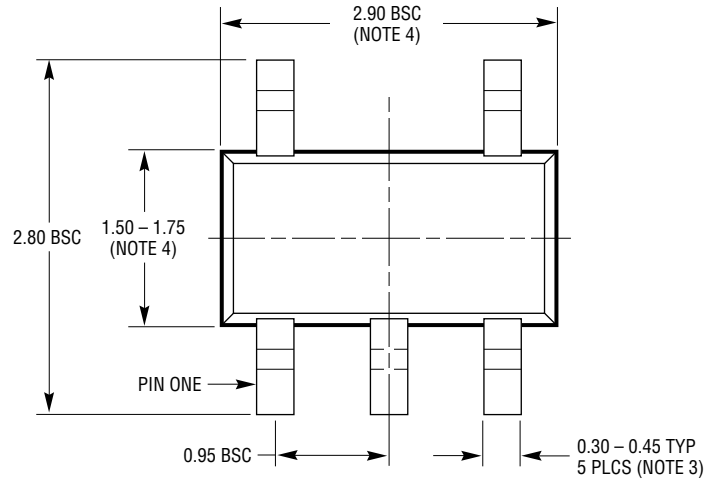
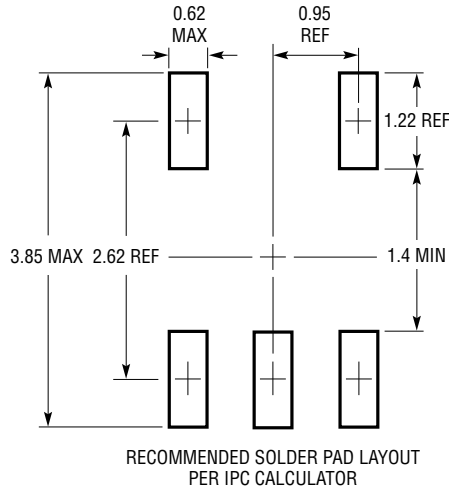

- NOTE:
1. DIMENSIONS ARE IN MILLIMETERS
 2. DRAWING NOT TO SCALE
 3. DIMENSIONS ARE INCLUSIVE OF PLATING
 4. DIMENSIONS ARE EXCLUSIVE OF MOLD FLASH AND METAL BURR
 5. MOLD FLASH SHALL NOT EXCEED 0.254mm
 6. JEDEC PACKAGE REFERENCE IS MO-193

S5 TSOT-23 0302 REV B

REVISION HISTORY

REV	DATE	DESCRIPTION	PAGE NUMBER
A	04/19	Added AEC-Q100 Qualified Front Page Feature Bullet	1
		Added Automotive (W) Flow Parts to Order Information Section	2
B	05/20	Added J-Grade Option and Specifications	2, 3

TYPICAL APPLICATION

8V to 36V_{IN}/12V_{OUT} Micropower Isolated Flyback Converter

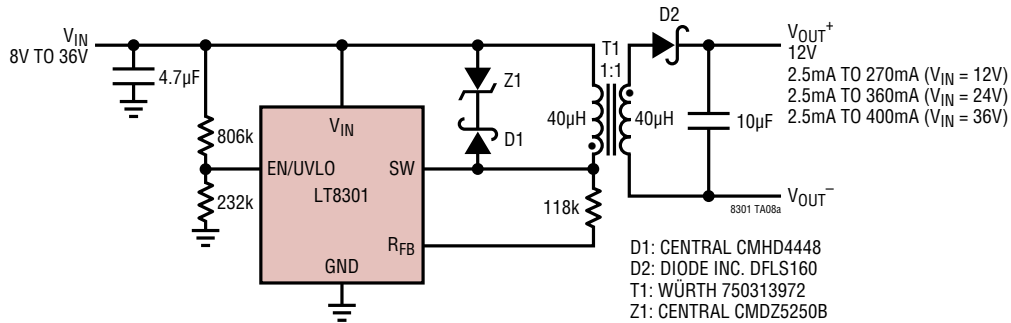

Efficiency vs Load Current

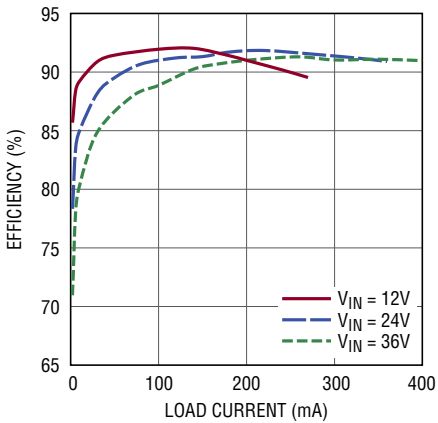

8301 TA08b

Output Load and Line Regulation

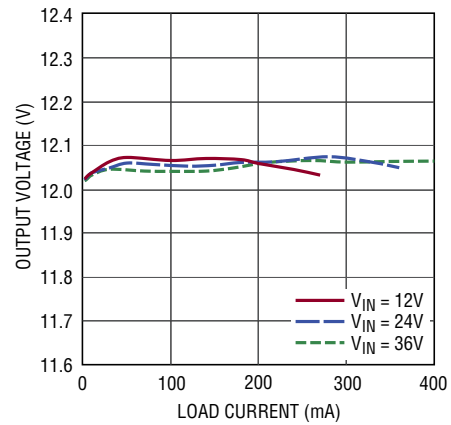

8301 TA08c

RELATED PARTS

PART NUMBER	DESCRIPTION	COMMENTS
LT8300	100V _{IN} Micropower Isolated Flyback Converter with 150V/260mA Switch	Low I _Q Monolithic No-Opto Flybacks, 5-Lead TSOT-23
LT8302	42V _{IN} Micropower Isolated Flyback Converter with 65V/3.6A Switch	Low I _Q Monolithic No-Opto Flybacks, 8-Lead SO-8E
LT8309	Secondary-Side Synchronous Rectifier Driver	4.5V ≤ V _{CC} ≤ 40V, Fast Turn-On and Turn-Off, 5-Lead TSOT-23
LT3511/LT3512	100V Isolated Flyback Converters	Monolithic No-Opto Flybacks with Integrated 240mA/420mA Switch, MSOP-16(12)
LT3748	100V Isolated Flyback Controller	5V ≤ V _{IN} ≤ 100V, No Opto Flyback, MSOP-16 with High Voltage Spacing
LT3798	Off-Line Isolated No Opto-Coupler Flyback Controller with Active PFC	V _{IN} and V _{OUT} Limited Only by External Components
LT3573/LT3574/LT3575	40V Isolated Flyback Converters	Monolithic No-Opto Flybacks with Integrated 1.25A/0.65A/2.5A Switch
LT3757A/LT3759/LT3758	40V/100V Flyback/Boost Controllers	Universal Controllers with Small Package and Powerful Gate Drive
LT3957/LT3958	40V/100V Flyback/Boost Converters	Monolithic with Integrated 5A/3.3A Switch
LTC®3803/LTC3803-3/LTC3803-5	200kHz/300kHz Flyback Controllers in SOT-23	V _{IN} and V _{OUT} Limited by External Components
LTC3805/LTC3805-5	Adjustable Frequency Flyback Controllers	V _{IN} and V _{OUT} Limited by External Components

Rev. B

X-ON Electronics

Largest Supplier of Electrical and Electronic Components

Click to view similar products for [Switching Voltage Regulators](#) category:

Click to view products by [Analog Devices](#) manufacturer:

Other Similar products are found below :

[FAN53610AUC33X](#) [FAN53611AUC123X](#) [FAN48610BUC33X](#) [FAN48610BUC45X](#) [FAN48617UC50X](#) [R3](#) [430464BB](#) [KE177614](#)
[FAN53611AUC12X](#) [MAX809TTR](#) [NCV891234MW50R2G](#) [NCP81103MNTXG](#) [NCP81203PMNTXG](#) [NCP81208MNTXG](#)
[NCP81109GMNTXG](#) [SCY1751FCCT1G](#) [NCP81109JMNTXG](#) [AP3409ADNTR-G1](#) [NCP81241MNTXG](#) [LTM8064IY](#) [LT8315EFE#TRPBF](#)
[LTM4664EY#PBF](#) [LTM4668AIY#PBF](#) [NCV1077CSTBT3G](#) [XCL207A123CR-G](#) [MPM54304GMN-0002](#) [MPM54304GMN-0004](#)
[MPM54304GMN-0003](#) [AP62300Z6-7](#) [MP8757GL-P](#) [MIC23356YFT-TR](#) [LD8116CGL](#) [HG2269M/TR](#) [OB2269](#) [XD3526](#) [U6215A](#) [U6215B](#)
[U6620S](#) [LTC3412IFE](#) [LT1425IS](#) [MAX25203BATJA/VY+](#) [MAX77874CEWM+](#) [XC9236D08CER-G](#) [MP3416GJ-P](#) [MP5461GC-Z](#)
[MPQ4590GS-Z](#) [MAX38640BENT18+T](#) [MAX77511AEWB+](#) [MAX20406AFOD/VY+](#) [MAX20408AFOC/VY+](#)