

# 100mA Ultralow Noise Charge Pump LED Supply with Output Current Adjust

## FEATURES

- Input Noise Filter Minimizes Supply Noise
- Constant Frequency Operation
- 3-Bit LED Current Control
- No Inductors
- Low Shutdown Current:  $I_{IN} < 1\mu A$
- Output Current: 100mA
- $V_{IN}$  Range: 2.7V to 4.5V
- 1.8MHz Switching Frequency
- Soft-Start Limits Inrush Current at Turn-On
- Short-Circuit and Overtemperature Protected
- Available in 10-Pin MSOP Package

## APPLICATIONS

- White LED Backlighting
- Programmable Boost Current Source

## DESCRIPTION

The LTC<sup>®</sup>3201 is an ultralow noise, constant frequency, charge pump DC/DC converter specifically designed for powering white LEDs. The part produces a low noise boosted supply capable of supplying 100mA of output current. LED current is regulated for accurate and stable backlighting. A 3-bit DAC provides output current adjust for brightness control.

Low external parts count (one small flying capacitor and three small bypass capacitors) and small MSOP-10 package size make the LTC3201 ideally suited for space constrained applications. An input noise filter further reduces input noise, thus enabling direct connection to the battery. High switching frequency enables the use of small external capacitors.

The LTC3201 contains overtemperature protection and can survive an indefinite output short to GND. Internal soft-start circuitry also prevents excessive inrush current on start-up. A low current shutdown feature disconnects the load from  $V_{IN}$  and reduces quiescent current to less than  $1\mu A$ .

LT, LTC and LT are registered trademarks of Linear Technology Corporation.

## TYPICAL APPLICATION

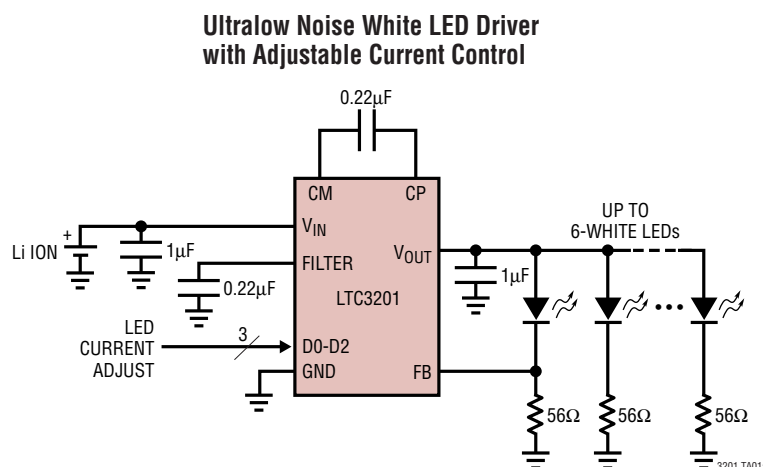

**Input Current Ripple**

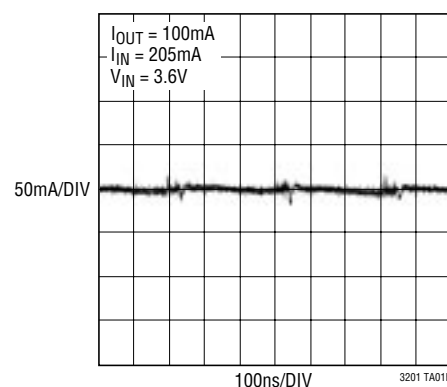

## ABSOLUTE MAXIMUM RATINGS

(Note 1)

$V_{IN}$ , $V_{FILTER}$ , $V_{OUT}$ , CP, CM to GND .....	-0.3V to 6V
D0, D1, D2, FB to GND .....	-0.3V to ( $V_{IN} + 0.3V$ )
$V_{OUT}$ Short-Circuit Duration .....	Indefinite
$I_{OUT}$ .....	150mA
Operating Temperature Range (Note 2) ...	-40°C to 85°C
Storage Temperature Range .....	-65°C to 150°C
Lead Temperature (Soldering, 10 sec) .....	300°C

## PACKAGE/ORDER INFORMATION

<p>MS PACKAGE 10-LEAD PLASTIC MSOP</p> <p><math>T_{JMAX} = 150^{\circ}C</math>  <math>\theta_{JA} = 130^{\circ}C/W</math> (1 LAYER BOARD)  <math>\theta_{JA} = 100^{\circ}C/W</math> (4 LAYER BOARD)</p>	ORDER PART NUMBER
	LTC3201EMS
	MS PART MARKING
	LTVB

Consult LTC Marketing for parts specified with wider operating temperature ranges.

## ELECTRICAL CHARACTERISTICS

The ● denotes the specifications which apply over the full operating temperature range, otherwise specifications are at  $T_A = 25^{\circ}C$ .  $V_{IN} = 3.6V$ ,  $C_{FILTER} = C_{FLY} = 0.22\mu F$ ,  $C_{IN} = C_{OUT} = 1\mu F$ ,  $t_{MIN}$  to  $t_{MAX}$  unless otherwise noted.

PARAMETER	CONDITIONS	MIN	TYP	MAX	UNITS
$V_{IN}$ Operating Voltage		● 2.7		4.5	V
$V_{IN}$ Operating Current	$I_{OUT} = 0mA$	●	4	6.5	mA
$V_{IN}$ Shutdown Current	D0, D1, D2 = 0V, $V_{OUT} = 0V$	●		1	$\mu A$
Open-Loop Output Impedance	$I_{OUT} = 100mA$		8		$\Omega$
Input Current Ripple	$I_{IN} = 200mA$		30		$mA_{P-P}$
Output Ripple	$I_{OUT} = 100mA$ , $C_{OUT} = 1\mu F$		30		$mV_{P-P}$
$V_{FB}$ Regulation Voltage	D0 = D1 = D2 = $V_{IN}$	● 0.57	0.63	0.66	V
$V_{FB}$ DAC Step Size			90		mV
Switching Frequency	Oscillator Free Running		1.4	1.8	MHz
D0 to D2 Input Threshold		● 0.4		1.1	V
D0 to D2 Input Current		● -1		1	$\mu A$
$V_{OUT}$ Short-Circuit Current	$V_{OUT} = 0V$		150		mA
$V_{OUT}$ Turn-On Time	$I_{OUT} = 0mA$		1		ms

**Note 1:** Absolute Maximum Ratings are those values beyond which the life of a device may be impaired.

**Note 2:** The LTC3201E is guaranteed to meet performance specifications from 0°C to 70°C. Specifications over the -40°C to 85°C operating temperature range are assured by design, characterization and correlation with statistical process controls.

# TYPICAL PERFORMANCE CHARACTERISTICS

**Feedback Voltage vs Supply Voltage**

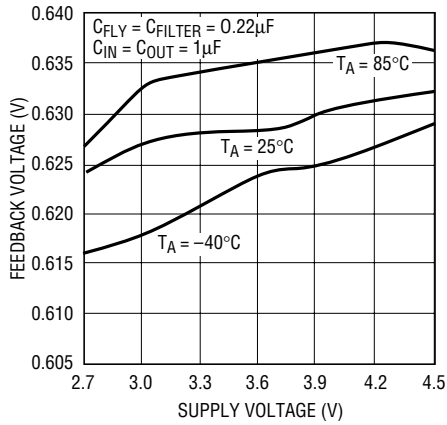

3201 G01

**Output Voltage vs Load Current**

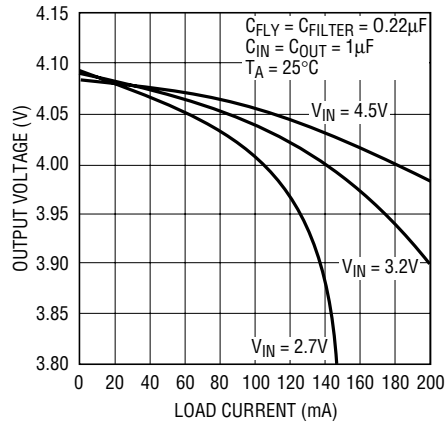

3201 G02

**Oscillator Frequency vs Supply Voltage**

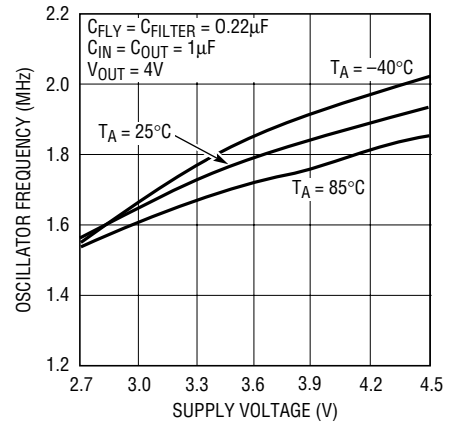

3201 G03

**Short-Circuit Current vs Supply Voltage**

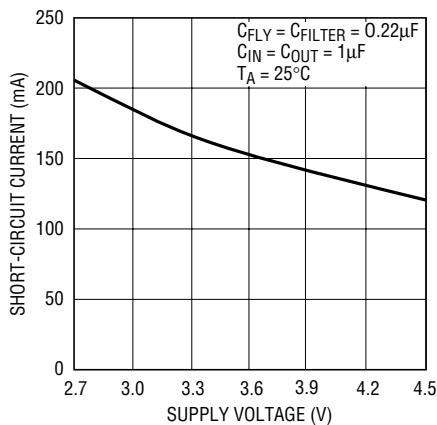

3201 G04

**Feedback Voltage vs Supply Voltage**  
 $I_{OUT} = 100mA, V_{OUT} = 4V$

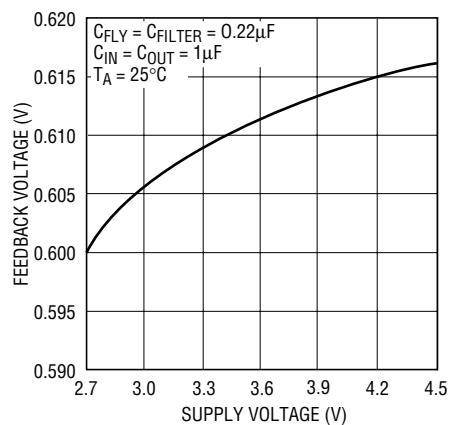

3201 G05

**Feedback Voltage vs I<sub>OUT</sub>**

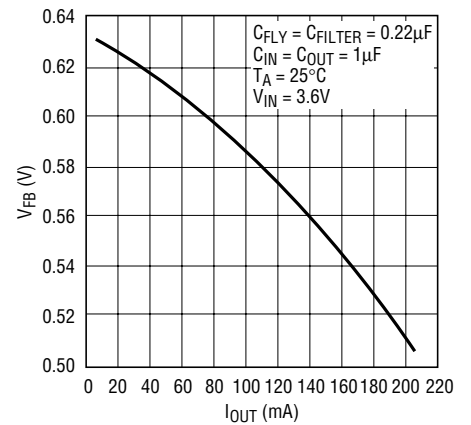

3201 G06

## PIN FUNCTIONS

**V<sub>OUT</sub> (Pin 1):** Charge Pump Output. Bypass with a 1 $\mu$ F ceramic capacitor to GND.

**CP (Pin 2):** Flying Capacitor Positive Terminal.

**FILTER (Pin 3):** Input Noise Filter Terminal. Bypass with a 0.22 $\mu$ F high resonant frequency ceramic capacitor to GND. Place filter capacitor less than 1/8" from device.

**CM (Pin 4):** Flying Capacitor Negative Terminal.

**GND (Pin 5):** Ground. Connect to a ground plane for best performance.

**D0 (Pin 6):** Current Control DAC LSB Input.

**D1 (Pin 7):** Current Control DAC Bit 1 Input.

**D2 (Pin 8):** Current Control DAC MSB Input. Inputs D0 to D2 program a 3-bit DAC output which is used as the

internal reference voltage. The DAC output reference voltage is used to regulate amount of current flowing through the LEDs. An internal control loop adjusts the charge pump output such that the voltage drop across an external sense resistor connected from FB to GND equals the internal DAC output reference voltage. See Truth Table in Applications Information section for internal reference settings vs DAC code. When D0 to D2 are low, the part enters a low current shutdown mode and the load is disconnected from V<sub>IN</sub>.

**V<sub>IN</sub> (Pin 9):** Input Voltage. V<sub>IN</sub> may be between 2.7V and 4.5V. Bypass V<sub>IN</sub> with a 1 $\mu$ F low ESR capacitor to ground.

**FB (Pin 10):** Charge Pump Feedback Input. This pin acts as a sense pin for I<sub>OUT</sub>. Connect a sense resistor between FB and GND to set the output current. I<sub>OUT</sub> will be adjusted until V<sub>FB</sub> = internal DAC output reference.

## SIMPLIFIED BLOCK DIAGRAM

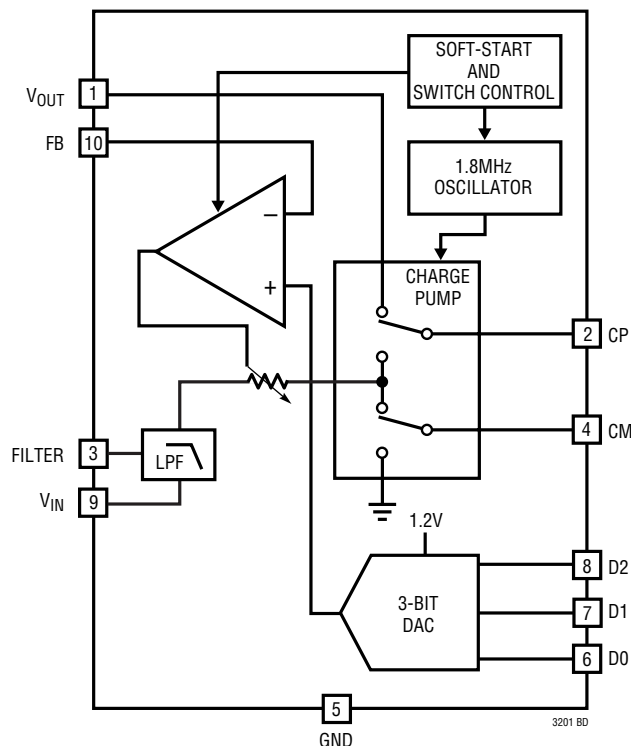

## APPLICATIONS INFORMATION

### Operation (Refer to Simplified Block Diagram)

The LTC3201 is a switched capacitor boost charge pump especially designed to drive white LEDs in backlighting applications. The LTC3201's internal regulation loop maintains constant LED output current by monitoring the voltage at the FB pin. The device has a novel internal filter that, along with an external 0.22 $\mu$ F capacitor, significantly reduces input current ripple. An internal 7-state DAC allows the user to lower the regulation voltage at the FB pin, thus lowering the LED current. To regulate the output current, the user places a sense resistor between FB and GND. The white LED is then placed between  $V_{OUT}$  and FB. The value at the FB pin is then compared to the output of the DAC. The charge pump output voltage is then changed to equalize the DAC output and the FB pin. The value of the sense resistor determines the maximum value of the output current.

When the charge pump is enabled, a two-phase nonoverlapping clock activates the charge pump switches. The flying capacitor is charged to  $V_{IN}$  on phase one of the clock. On phase two of the clock, it is stacked in series with  $V_{IN}$  and connected to  $V_{OUT}$ . This sequence of charging and discharging the flying capacitor continues at a free running frequency of 1.8MHz (typ) until the FB pin voltage reaches the value of the DAC.

In shutdown mode all circuitry is turned off and the LTC3201 draws only leakage current (<1 $\mu$ A) from the  $V_{IN}$  supply. Furthermore,  $V_{OUT}$  is disconnected from  $V_{IN}$ . The LTC3201 is in shutdown when a logic low is applied to all three D0:D2 pins. Note that if  $V_{OUT}$  floats to >1.5V, shutdown current will increase to 10 $\mu$ A max. In normal operation, the quiescent supply current of the LTC3201 will be slightly higher if any of the D0:D2 pins is driven high with a signal that is below  $V_{IN}$  than if it is driven all the way to  $V_{IN}$ . Since the D0:D2 pins are high impedance CMOS inputs, they should never be allowed to float.

### Input Current Ripple

The LTC3201 is designed to minimize the current ripple at  $V_{IN}$ . Typical charge pump boost converters draw large amounts of current from  $V_{IN}$  during both phase 1 and phase 2 of the clocking. If there is a large nonoverlap time between the two phases, the current being drawn from  $V_{IN}$

can go down to zero during this time. At the full load of 100mA at the output, this means that the input could potentially go from 200mA down to 0mA during the nonoverlap time. The LTC3201 mitigates this problem by minimizing the nonoverlap time, using a high (1.8MHz) frequency clock, and employing a novel noise FILTER network. The noise filter consists of internal circuitry plus external capacitors at the FILTER and  $V_{IN}$  pins. The filter capacitor serves to cancel the higher frequency components of the noise, while the  $V_{IN}$  capacitor cancels out the lower frequency components. The recommended values are 0.22 $\mu$ F for the FILTER capacitor and 1 $\mu$ F for the  $V_{IN}$  capacitor. Note that these capacitors must be of the highest possible resonant frequencies. See Layout Considerations.

### 3-Bit DAC for Output Current Control

Digital pins D0, D1, D2 are used to control the output current level.  $D0 = D1 = D2 = V_{IN}$  allows the user to program an output LED current that is equal to  $0.63V/R_{SENSE}$ , where  $R_{SENSE}$  is the resistor connected to any single LED and connected between FB and ground. Due to the finite transconductance of the regulation loop, for a given diode setting, the voltage at the FB Pin will decrease as output current increases. All LEDs subsequently connected in parallel should then have similar currents. The mismatching of the LED  $V_F$  and the mismatching of the sense resistors will cause a differential current error between LEDs connected to the same output. Once the sense resistor is selected, the user can then control the voltage applied across that resistor by changing the digital values at D0:D2. This in turn controls the current into the LED. Note that there are only 7 available current states. The 8th is reserved to shutdown. This is the all 0s code. Refer to Table below.

D0	D1	D2	FB
HIGH	HIGH	HIGH	0.63V
HIGH	HIGH	LOW	0.54V
HIGH	LOW	HIGH	0.45V
HIGH	LOW	LOW	0.36V
LOW	HIGH	HIGH	0.27V
LOW	HIGH	LOW	0.18V
LOW	LOW	HIGH	0.09V
LOW	LOW	LOW	Shutdown

## APPLICATIONS INFORMATION

### Power Efficiency

The power efficiency ( $\eta$ ) of the LTC3201 is similar to that of a linear regulator with an effective input voltage of twice the actual input voltage. This occurs because the input current for a voltage doubling charge pump is approximately twice the output current. In an ideal regulator the power efficiency would be given by:

$$\eta = \frac{P_{OUT}}{P_{IN}} = \frac{V_{OUT} \cdot I_{OUT}}{V_{IN} \cdot 2I_{OUT}} = \frac{V_{OUT}}{2V_{IN}}$$

At moderate to high output power the switching losses and quiescent current of LTC3201 are relatively low. Due to the high clocking frequency, however, the current used for charging and discharging the switches starts to reduce efficiency. Furthermore, due to the low  $V_F$  of the LEDs, power delivered will remain low.

### Short-Circuit/Thermal Protection

The LTC3201 has short-circuit current limiting as well as overtemperature protection. During short-circuit conditions, the output current is limited to typically 150mA. On-chip thermal shutdown circuitry disables the charge pump once the junction temperature exceeds approximately 160°C and re-enables the charge pump once the junction temperature drops back to approximately 150°C. The LTC3201 will cycle in and out of thermal shutdown indefinitely without latching or damage until the short-circuit on  $V_{OUT}$  is removed.

### $V_{OUT}$ Capacitor Selection

The style and value of capacitors used with the LTC3201 determine several important parameters such as output ripple, charge pump strength and minimum start-up time.

To reduce noise and ripple, it is recommended that low ESR ( $<0.1\Omega$ ) capacitors be used for  $C_{FILTER}$ ,  $C_{IN}$ ,  $C_{OUT}$ . These capacitors should be ceramic.

The value of  $C_{OUT}$  controls the amount of output ripple. Increasing the size of  $C_{OUT}$  to 10 $\mu$ F or greater will reduce the output ripple at the expense of higher turn-on times and start-up current. See the section Output Ripple. A 1 $\mu$ F  $C_{OUT}$  is recommended.

### $V_{IN}$ , $V_{FILTER}$ Capacitor Selection

The value and resonant frequency of  $C_{FILTER}$  and  $C_{IN}$  greatly determine the current noise profile at  $V_{IN}$ .  $C_{FILTER}$  should be a high frequency 0.22 $\mu$ F capacitor with a resonant frequency over 30MHz. Input capacitor  $C_{IN}$  should be a 1 $\mu$ F ceramic capacitor with a resonant frequency over 1MHz. The X5R capacitor is a good choice for both. The values of  $C_{FILTER}$  (0.22 $\mu$ F) and  $C_{IN}$  (1 $\mu$ F) provide optimum high and low frequency input current filtering. A higher filter cap value will result in lower low frequency input current ripple, but with increased high frequency ripple. The key at the FILTER node is that the capacitor has to be very high frequency. If capacitor technology improves the bandwidth, then higher values should be used. Similarly, increasing the input capacitor value but decreasing its resonant frequency will not really help. Decreasing it will help the high frequency performance while increasing the low frequency current ripple.

### Direct Connection to Battery

Due to the ultra low input current ripple, it is possible to connect the LTC3201 directly to the battery without using regulators or high frequency chokes.

### Flying Capacitor Selection

*Warning: A polarized capacitor such as tantalum or aluminum should never be used for the flying capacitor since its voltage can reverse upon start-up. Low ESR ceramic capacitors should always be used for the flying capacitor.*

The flying capacitor controls the strength of the charge pump. In order to achieve the rated output current it is necessary to have at least 0.22 $\mu$ F of capacitance for the flying capacitor. Capacitors of different materials lose their capacitance with higher temperature and voltage at different rates. For example, a ceramic capacitor made of X7R material will retain most of its capacitance from -40°C to 85°C whereas a Z5U and Y5V style capacitor will lose considerable capacitance over that range. Z5U and Y5V capacitors may also have a very strong voltage coefficient causing them to lose 60% or more of their capacitance when the rated voltage is applied. Therefore, when comparing different capacitors it is often more



## APPLICATIONS INFORMATION

appropriate to compare the achievable capacitance for a given case size rather than discussing the specified capacitance value. For example, over the rated voltage and temperature, a 1 $\mu$ F, 10V, Y5V ceramic capacitor in an 0603 case may not provide any more capacitance than a 0.22 $\mu$ F 10V X7R available in the same 0603 case. The capacitor manufacturer's data sheet should be consulted to determine what value of capacitor is needed to ensure 0.22 $\mu$ F at all temperatures and voltages.

Below is a list of ceramic capacitor manufacturers and how to contact them:

AVX	(843) 448-9411	www.avxcorp.com
Kemet	(864) 963-6300	www.kemet.com
Murata	(770) 436-1300	www.murata.com
Taiyo Yuden	(800) 348-2496	www.t-yuden.com
Vishay	(610) 644-1300	www.vishay.com

### Open-Loop Output Impedance

The theoretical minimum open-loop output impedance of a voltage doubling charge pump is given by:

$$R_{OUT(MIN)} = \frac{2V_{IN} - V_{OUT}}{I_{OUT}} = \frac{1}{FC}$$

where F is the switching frequency (1.8MHz typ) and C is the value of the flying capacitor. (Using units of MHz and  $\mu$ F is convenient since they cancel each other). Note that the charge pump will typically be weaker than the theoretical limit due to additional switch resistance. Under normal operation, however, with  $V_{OUT} \approx 4V$ ,  $I_{OUT} < 100mA$ ,  $V_{IN} > 3V$ , the output impedance is given by the closed-loop value of  $\sim 0.5\Omega$ .

### Output Ripple

The value of  $C_{OUT}$  directly controls the amount of ripple for a given load current. Increasing the size of  $C_{OUT}$  will reduce the output ripple at the expense of higher minimum turn-on time and higher start-up current. The peak-to-peak output ripple is approximated by the expression:

$$V_{RIPPLE(P-P)} \cong \frac{I_{OUT}}{2F \cdot C_{OUT}}$$

F is the switching frequency (1.8MHz typ).

### Loop Stability

Both the style and the value of  $C_{OUT}$  can affect the stability of the LTC3201. The device uses a closed loop to adjust the strength of the charge pump to match the required output current. The error signal of this loop is directly stored on the output capacitor. The output capacitor also serves to form the dominant pole of the loop. To prevent ringing or instability, it is important for the output capacitor to maintain at least 0.47 $\mu$ F over all ambient and operating conditions.

Excessive ESR on the output capacitor will degrade the loop stability of the LTC3201. The closed loop DC impedance is nominally 0.5 $\Omega$ . The output will thus change by 50mV with a 100mA load. Output capacitors with ESR of 0.3 $\Omega$  or greater could cause instability or poor transient response. To avoid these problems, ceramic capacitors should be used. A tight board layout with good ground plane is also recommended.

### Soft-Start

The LTC3201 has built-in soft-start circuitry to prevent excessive input current flow at  $V_{IN}$  during start-up. The soft-start time is programmed at approximately 30 $\mu$ s.

### Layout Considerations

Due to the high switching frequency and large transient currents produced by the LTC3201, careful board layout is necessary. A true ground plane is a must. To minimize high frequency input noise ripple, it is especially important that the filter capacitor be placed with the shortest distance to the LTC3201 (1/8 inch or less). The filter capacitor should have the highest possible resonant frequency. Conversely, the input capacitor does not need to be placed close to the pin. The input capacitor serves to cancel out the lower frequency input noise ripple. Extra inductance on the  $V_{IN}$  line actually helps input current ripple. Note that if the  $V_{IN}$  trace is lengthened to add parasitic inductance, it starts to look like an antenna and worsen the radiated noise. It is recommended that the filter capacitor be placed on the left hand side next to Pin 3. The flying capacitor can then be placed on the top of the device. It is also important

## TYPICAL APPLICATION

to place the output capacitor as close to the pin as possible to minimize inductive ringing and parasitic resistance.

### Thermal Management

For higher input voltages and maximum output current there can be substantial power dissipation in the LTC3201. If the junction temperature increases above approximately 160°C the thermal shutdown circuitry will

automatically deactivate the output. To reduce the maximum junction temperature, a good thermal connection to PC board is recommended. Connecting the GND pin (Pin 4) to a ground plane, and maintaining a solid ground plane under the device on two layers of the PC board can reduce the thermal resistance of the package and PC board system.

## PACKAGE DESCRIPTION

**MS Package**  
**10-Lead Plastic MSOP**  
(Reference LTC DWG # 05-08-1661)

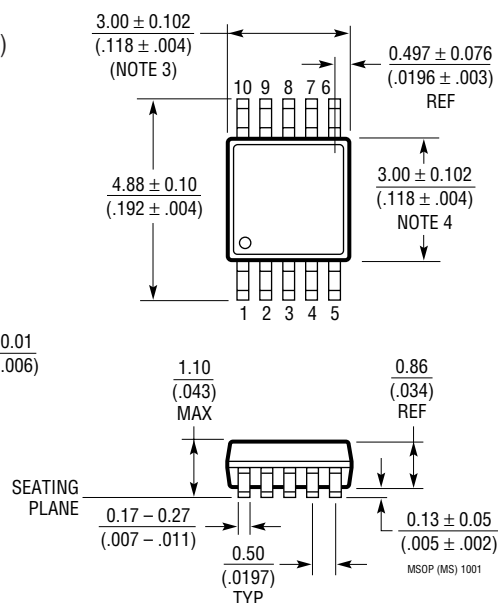
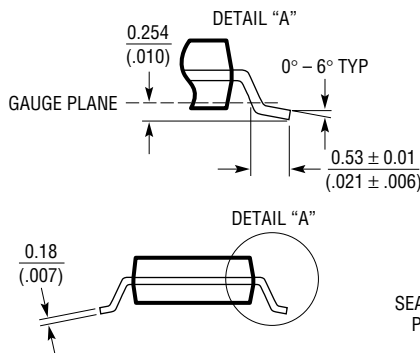
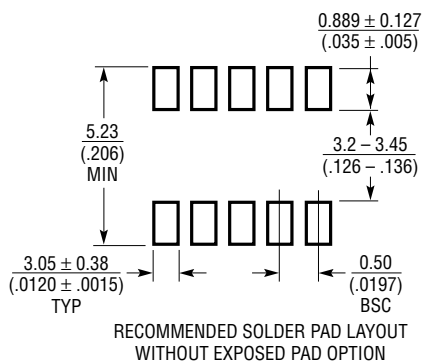

**NOTE:**

1. DIMENSIONS IN MILLIMETER/(INCH)
2. DRAWING NOT TO SCALE
3. DIMENSION DOES NOT INCLUDE MOLD FLASH, PROTRUSIONS OR GATE BURRS. MOLD FLASH, PROTRUSIONS OR GATE BURRS SHALL NOT EXCEED 0.152mm (.006") PER SIDE
4. DIMENSION DOES NOT INCLUDE INTERLEAD FLASH OR PROTRUSIONS. INTERLEAD FLASH OR PROTRUSIONS SHALL NOT EXCEED 0.152mm (.006") PER SIDE
5. LEAD COPLANARITY (BOTTOM OF LEADS AFTER FORMING) SHALL BE 0.102mm (.004") MAX

## RELATED PARTS

PART NUMBER	DESCRIPTION	COMMENTS
LTC1682/-3.3/-5	Doubler Charge Pumps with Low Noise LDO	MS8 and SO-8 Packages, I <sub>OUT</sub> = 80mA, Output Noise = 60μV <sub>RMS</sub>
LTC1751/-3.3/-5	Doubler Charge Pumps	V <sub>OUT</sub> = 5V at 100mA, V <sub>OUT</sub> = 3.3V at 80mA, ADJ, MSOP Packages
LTC1754-3.3/-5	Doubler Charge Pumps with Shutdown	ThinSOT™ Package, I <sub>Q</sub> = 13μA, I <sub>OUT</sub> = 50mA
LTC1928-5	Doubler Charge Pumps with Low Noise LDO	ThinSOT Output Noise = 90μV <sub>RMS</sub> , V <sub>OUT</sub> = 5V, V <sub>IN</sub> = 2.7V to 4.4V
LT1932	Low Noise Boost Regulator LED Driver	ThinSOT Package, High Efficiency, up to 16 LEDs
LTC3200/-5	Low Noise Doubler Charge Pump	MS8 and ThinSOT (LTC3200-5) Package, I <sub>OUT</sub> = 100mA, 2MHz Fixed Frequency
LTC3202	Low Noise High Efficiency Charge Pump	MS10 Package, 125mA Output, High Efficiency

ThinSOT is a trademark of Linear Technology Corporation.



## X-ON Electronics

Largest Supplier of Electrical and Electronic Components

*Click to view similar products for [LED Lighting Drivers](#) category:*

*Click to view products by [Analog Devices](#) manufacturer:*

Other Similar products are found below :

[LV5235V-MPB-H](#) [MB39C602PNF-G-JNEFE1](#) [MIC2871YMK-T5](#) [AL1676-10BS7-13](#) [AL1676-20AS7-13](#) [AP5726WUG-7](#) [ICL8201](#)  
[IS31BL3228B-UTLS2-TR](#) [IS31BL3506B-TTLS2-TR](#) [AL3157F-7](#) [AP5725FDCG-7](#) [LV52204MTTBG](#) [AP5725WUG-7](#) [STP4CMPQTR](#)  
[NCL30086BDR2G](#) [CAT4004BHU2-GT3](#) [LV52207AXA-VH](#) [AP1694AS-13](#) [TLE4242EJ](#) [KTD2027EWE-TR](#) [AS3688](#) [IS31LT3172-GRLS4-TR](#) [TLD2311EL](#) [KTD2694EDQ-TR](#) [KTZ8864EJAA-TR](#) [IS32LT3174-GRLA3-TR](#) [MP2488DN-LF-Z](#) [NLM0010XTSA1](#) [AL1676-20BS7-13](#)  
[ZXLD1370QESTTC](#) [MPQ7220GF-AEC1-P](#) [MPQ7220GR-AEC1-P](#) [MPQ4425BGJ-AEC1-P](#) [MPQ7220GF-AEC1-Z](#) [MPQ4425BGJ-AEC1-Z](#)  
[IS31FL3737B-QFLS4-TR](#) [IS31FL3239-QFLS4-TR](#) [KTD2058EUAC-TR](#) [KTD2037EWE-TR](#) [DIO5662ST6](#) [KTD2026BEWE-TR](#)  
[MAX20052CATC/V+](#) [MAX25606AUP/V+](#) [BD6586MUV-E2](#) [BD9206EFV-E2](#) [LYT4227E](#) [LYT6079C-TL](#) [MP3394SGF-P](#) [MP4689AGN-P](#)  
[MPQ4425AGQB-AEC1-Z](#)