

# 5V, 4A Synchronous Step-Down Silent Switcher in 2mm x 2mm LQFN

## FEATURES

- Pin Compatible with LTC3307(3A) and LTC3309(6A)
- High Efficiency: 8mΩ NMOS, 31mΩ PMOS
- Programmable Frequency 1MHz to 3MHz
  - Tiny Inductor and Capacitors
- Peak Current Mode Control
  - 22ns Minimum On-Time
  - Wide Bandwidth, Fast Transient Response
- Silent Switcher® Architecture
  - Ultralow EMI Emissions
- Low Ripple Burst Mode® Operation with I<sub>Q</sub> of 40μA
- Safely Tolerates Inductor Saturation in Overload
- V<sub>IN</sub> Range: 2.25V to 5.5V
- V<sub>OUT</sub> Range: 0.5V to V<sub>IN</sub>
- V<sub>OUT</sub> Accuracy: ±1% Over Temperature Range
- Precision 400mV Enable Threshold, 1μA in Shutdown
- Power Good, Internal Compensation and Soft Start
- Thermally Enhanced 2mm × 2mm LQFN Package
- AEC-Q100 Qualified for Automotive Applications

## DESCRIPTION

The **LTC®3308A** is a very small, high efficiency, low noise, monolithic synchronous 4A step-down DC/DC converter operating from a 2.25V to 5.5V input supply. Using constant frequency, peak current mode control at switching frequencies 1MHz to 3MHz and minimum on-time as low as 22ns, this regulator achieves fast transient response with small external components. Silent Switcher architecture minimizes EMI emissions.

The LTC3308A operates in forced continuous or pulse skip mode for low noise, or low-ripple Burst Mode operation for high efficiency at light loads, ideal for battery-powered systems. The IC regulates output voltages as low as 500mV. Other features include output overvoltage protection, short-circuit protection, thermal shutdown, clock synchronization, and up to 100% duty cycle operation for low dropout. The device is available in a low profile 12-lead 2mm × 2mm × 0.74mm LQFN package with exposed pad for low thermal resistance.

All registered trademarks and trademarks are the property of their respective owners.

## APPLICATIONS

- Optical Networking, Servers, Telecom
- Automotive, Industrial, Communications
- Distributed DC Power Systems (POL)
- FPGA, ASIC, μP Core Supplies
- Battery Operated Systems

## TYPICAL APPLICATION

**High Efficiency, 2MHz, 1.2V 4A Step-Down Converter**

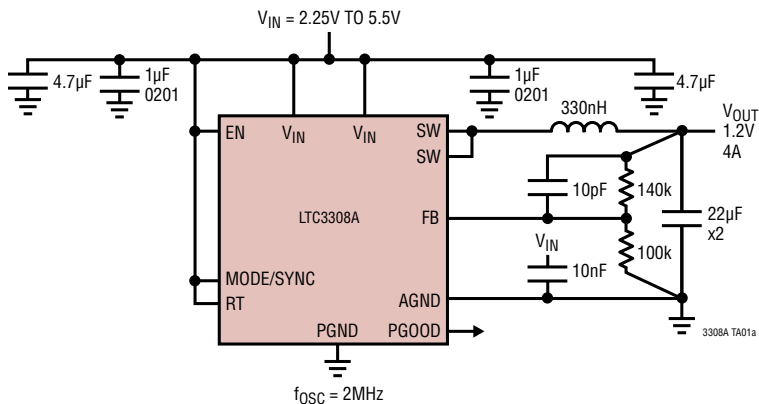

**Efficiency and Power Loss in Burst Mode Operation**

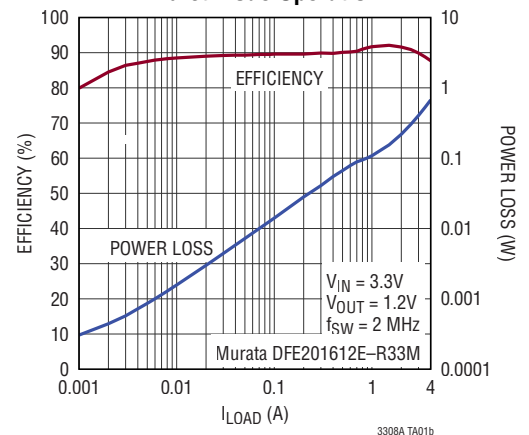

# LTC3308A

## ABSOLUTE MAXIMUM RATINGS

(Note 1)

$V_{IN}$ .....	-0.3V to 6V
EN .....	-0.3V to Lesser of ( $V_{IN} + 0.3V$ ) or 6V
FB .....	-0.3V to Lesser of ( $V_{IN} + 0.3V$ ) or 6V
MODE/SYNC .....	-0.3V to Lesser of ( $V_{IN} + 0.3V$ ) or 6V
RT .....	-0.3V to Lesser of ( $V_{IN} + 0.3V$ ) or 6V
AGND to PGND .....	-0.3V to +0.3V
PGOOD .....	-0.3V to 6V

$I_{PGOOD}$ .....5mA

Operating Junction Temperature Range (Note 2):

LTC3308AE .....	-40°C to +125°C
LTC3308AI .....	-40°C to +125°C
LTC3308AJ .....	-40°C to +150°C
LTC3308AH .....	-40°C to +150°C
LTC3308AMP .....	-55°C to +150°C

Storage Temperature Range .....-65°C to +150°C

Maximum Reflow (Package Body) Temperature ... 260°C

## PIN CONFIGURATION

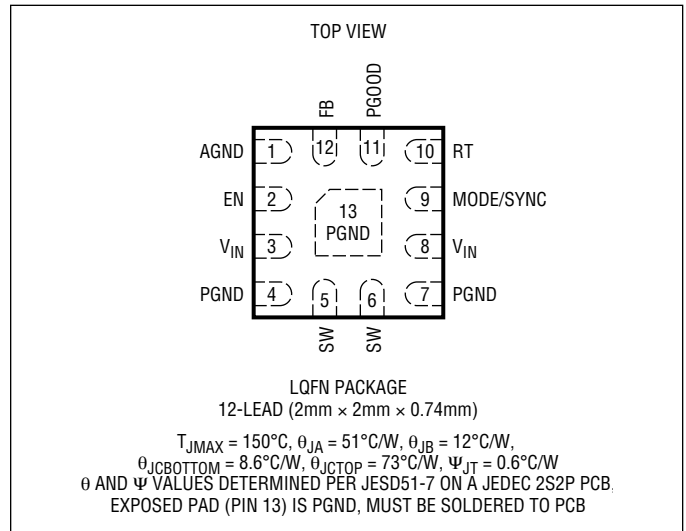

## ORDER INFORMATION

TAPE AND REEL	TAPE AND REEL MINI	PART MARKING*	PACKAGE TYPE	TEMPERATURE RANGE
LTC3308AEV#TRPBF	LTC3308AEV#TRMPBF	LHFT	LQFN (Laminate Package with QFN Footprint)	-40°C to 125°C
LTC3308AIV#TRPBF	LTC3308AIV#TRMPBF	LHFT		-40°C to 125°C
LTC3308AJV#TRPBF	LTC3308AJV#TRMPBF	LHFT		-40°C to 150°C
LTC3308AHV#TRPBF	LTC3308AHV#TRMPBF	LHFT		-40°C to 150°C
LTC3308AMPV#TRPBF	LTC3308AMPV#TRMPBF	LHFT		-55°C to 150°C

### AUTOMOTIVE PRODUCTS\*\*

LTC3308AEV#WTRPBF	LTC3308AEV#WTRMPBF	LHFT	LQFN (Laminate Package with QFN Footprint)	-40°C to 125°C
LTC3308AIV#WTRPBF	LTC3308AIV#WTRMPBF	LHFT		-40°C to 125°C
LTC3308AJV#WTRPBF	LTC3308AJV#WTRMPBF	LHFT		-40°C to 150°C
LTC3308AHV#WTRPBF	LTC3308AHV#WTRMPBF	LHFT		-40°C to 150°C

Contact the factory for parts specified with wider operating temperature ranges. \*The temperature grade is identified by a label on the shipping container.

**Tape and reel specifications.** Some packages are available in 500 unit reels through designated sales channels with #TRMPBF suffix.

\*\*Versions of this part are available with controlled manufacturing to support the quality and reliability requirements of automotive applications. These models are designated with a #W suffix. Only the automotive grade products shown are available for use in automotive applications. Contact your local Analog Devices account representative for specific product ordering information and to obtain the specific Automotive Reliability reports for these models.

## ELECTRICAL CHARACTERISTICS

The ● denotes the specifications which apply over the specified operating junction temperature range (Note 2), otherwise specifications are at  $T_A = 25^\circ\text{C}$ ;  $V_{IN} = 3.3\text{V}$ ,  $V_{EN} = V_{IN}$ , unless otherwise noted.

PARAMETER	CONDITIONS		MIN	TYP	MAX	UNITS
<b>Input Supply</b>						
Operating Supply Voltage ( $V_{IN}$ )		●	2.25		5.5	V
$V_{IN}$ Undervoltage Lockout	$V_{IN}$ Rising	●	2.0	2.1	2.2	V
$V_{IN}$ Undervoltage Lockout Hysteresis				150		mV
$V_{IN}$ Quiescent Current in Shutdown	$V_{EN} = 0.1\text{V}$			1	2	$\mu\text{A}$
$V_{IN}$ Quiescent Current (Note 3)	Burst Mode Operation, Sleeping All Modes, Not Sleeping			40 1.2	60 2	$\mu\text{A}$ mA
Enable Threshold	$V_{EN}$ Rising	●	0.375	0.4	0.425	V
Enable Threshold Hysteresis				50		mV
EN Pin Leakage	$V_{EN} = 0.5\text{V}$				$\pm 20$	nA
<b>Voltage Regulation</b>						
Regulated Feedback Voltage ( $V_{FB}$ )		●	0.495	0.5	0.505	V
Feedback Voltage Line Regulation	$V_{IN} = 2.25\text{V}$ to $5.5\text{V}$			0.015	0.05	%/V
FB Pin Input Current	$V_{FB} = 0.5\text{V}$				$\pm 20$	nA
Minimum On Time ( $t_{ON,min}$ )	$V_{IN} = 5.5\text{V}$	●		22	42	ns
Maximum Duty Cycle		●	100			%
Top Switch ON-Resistance				31		m $\Omega$
Bottom Switch ON-Resistance				8		m $\Omega$
Top Switch Current Limit ( $I_{PEAKMAX}$ )	$V_{OUT}/V_{IN} \leq 0.2$		6.0	6.4	6.8	A
Bottom Switch Current Limit ( $I_{VALLEYMAX}$ )				5.2		A
Bottom Switch Reverse Current Limit ( $I_{REVMAX}$ )	Forced Continuous Mode		-1.0	-2.0	-3.0	A
SW Leakage Current	$V_{EN} = 0.1\text{V}$			$\pm 100$		nA
<b>Power Good and Soft-Start</b>						
PGOOD Rising Threshold	As a Percentage of the Regulated $V_{OUT}$	●	97	98	99	%
PGOOD Hysteresis		●	0.7	1.2	1.7	%
Overvoltage Rising Threshold	As a Percentage of the Regulated $V_{OUT}$	●	107	110	114	%
Overvoltage Hysteresis		●	1	2.2	3.5	%
PGOOD Delay				120		$\mu\text{s}$
PGOOD Pull Down Resistance	$V_{PGOOD} = 0.1\text{V}$			10	20	$\Omega$
PGOOD Leakage Current	$V_{PGOOD} = 5.5\text{V}$				20	nA
Soft-Start Duration	$V_{OUT}$ rising from 0V to PGOOD Threshold	●	0.25	1	3	ms
<b>Oscillator and MODE/SYNC</b>						
Default Oscillator Frequency		●	1.9	2	2.1	MHz
Oscillator Frequency with $R_T = 34.8\text{k}\Omega$		●	1.9	2	2.1	MHz
Frequency Range	$R_T$ Programming and Synchronization	●	1		3	MHz
Minimum SYNC High or Low Pulse Width		●	40			ns
SYNC Pulse Voltage Levels	Level High Level Low	● ●	1.2		0.4	V V
MODE/SYNC No Clock Detect Time				10		$\mu\text{s}$
MODE/SYNC Pin Threshold	For Programming Pulse Skip Mode For Programming Forced Continuous Mode For Programming Burst Mode Operation	● ● ●	1.0 $V_{IN} - 0.1$	Float	0.1 $V_{IN} - 1.0$	V V V

## ELECTRICAL CHARACTERISTICS

**Note 1:** Stresses beyond those listed under Absolute Maximum Ratings may cause permanent damage to the device. Exposure to any Absolute Maximum Rating condition for extended periods may affect device reliability and lifetime.

**Note 2:** The LTC3308A is tested under pulsed load conditions such that  $T_J \approx T_A$ . The LTC3308AE is guaranteed to meet specifications from 0°C to 85°C junction temperature. Specifications over the –40°C to 125°C operating junction temperature range are assured by design, characterization, and correlation with statistical process controls. The LTC3308AI is guaranteed over the –40°C to 125°C operating junction temperature range. The LTC3308AJ and LTC3308AH are guaranteed over the –40°C to 150°C operating junction temperature range. The LTC3308AMP is guaranteed over the –55°C to 150°C operating junction temperature range. High junction temperatures degrade operating lifetimes; operating lifetime is derated for junction temperatures above 125°C. Note that the maximum ambient temperature consistent with

these specifications is determined by specific operating conditions in conjunction with board layout, the rated package thermal impedance, and other environmental factors. The junction temperature ( $T_J$  in °C) is calculated from ambient temperature ( $T_A$  in °C) and power dissipation ( $P_D$  in Watts) according to the formula:

$T_J = T_A + (P_D \cdot \theta_{JA})$ , where  $\theta_{JA}$  (in °C/W) is the package thermal impedance. See High Temperature Considerations section for more details.

The LTC3308A includes overtemperature protection that protects the device during momentary overload conditions. Junction temperatures will exceed 150°C when overtemperature protection is engaged. Continuous operation above the specified maximum operating junction temperature may impair device reliability.

**Note 3:** Supply current specification does not include switching currents. Actual supply currents will be higher.

**TYPICAL PERFORMANCE CHARACTERISTICS**  $V_{IN} = 3.3V$ ,  $T_A = 25^\circ C$ , unless otherwise noted.

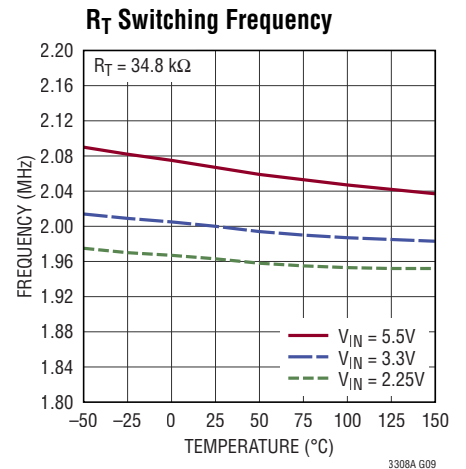
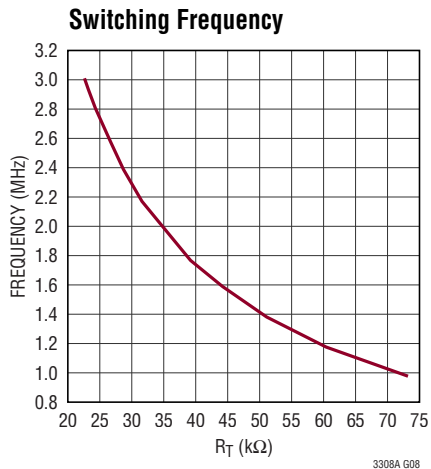
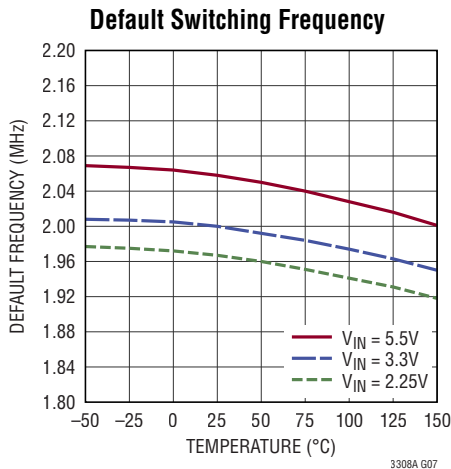
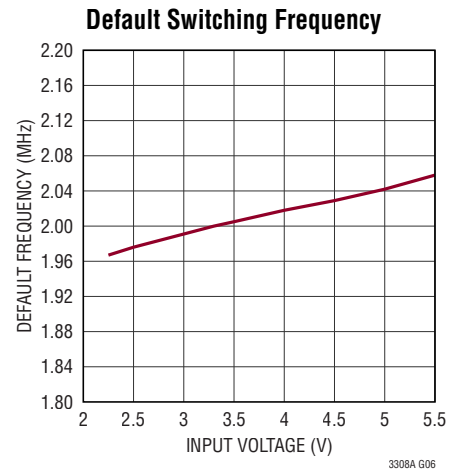
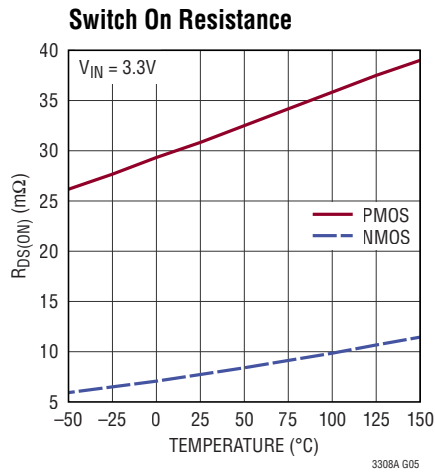
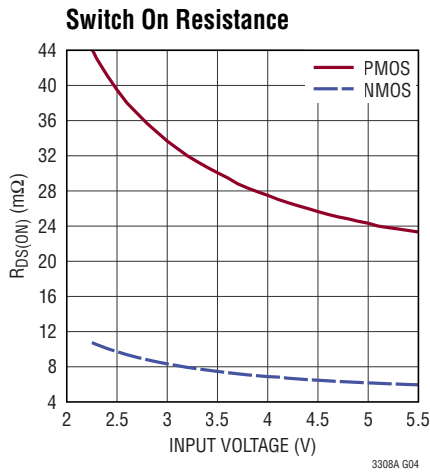
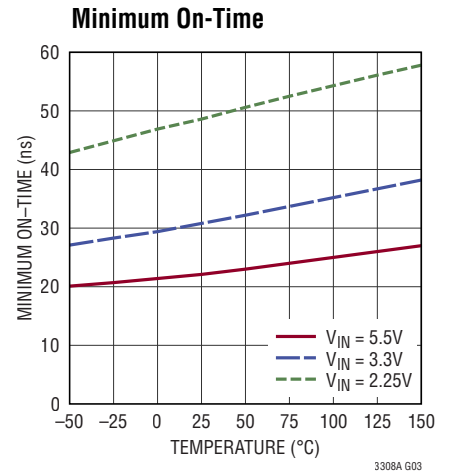
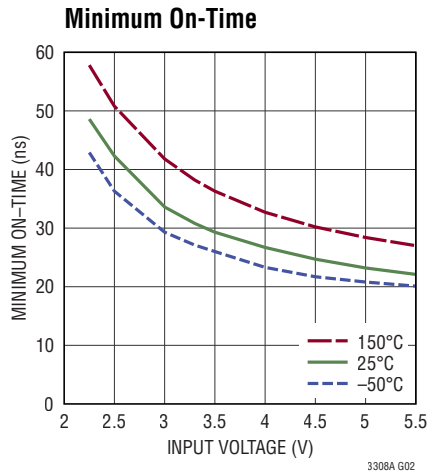
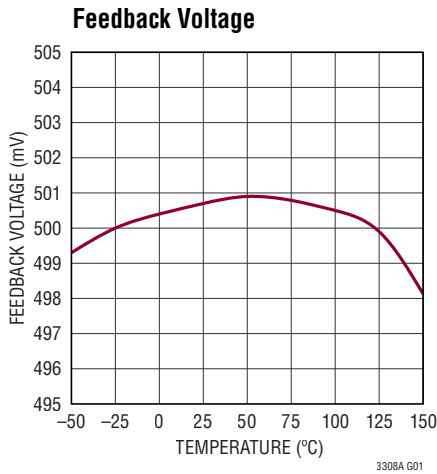

## TYPICAL PERFORMANCE CHARACTERISTICS $V_{IN} = 3.3V$ , $T_A = 25^\circ C$ , unless otherwise noted.

### Switch Current Limits

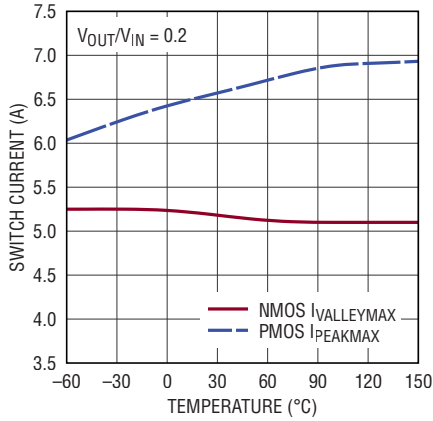

### PMOS Current Limit

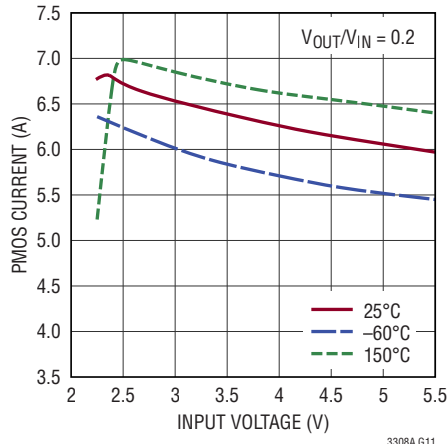

### PMOS Current Limit

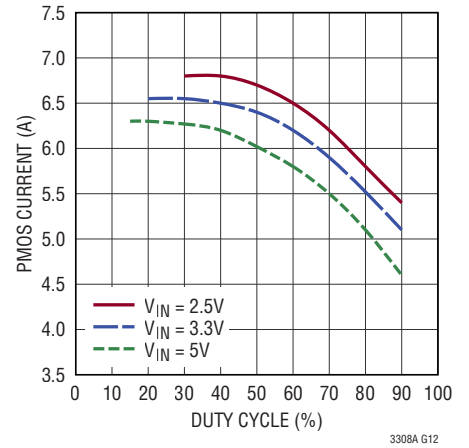

### $V_{IN}$ Shutdown Current

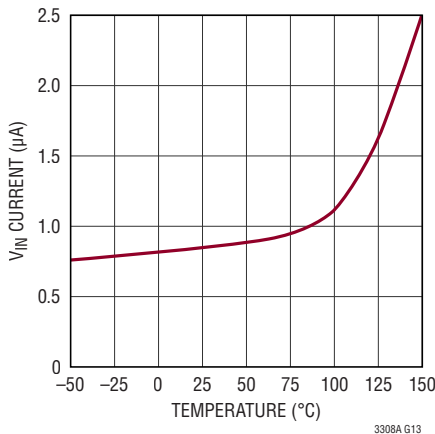

### $V_{IN}$ Quiescent Current, Burst Mode Operation, Sleeping

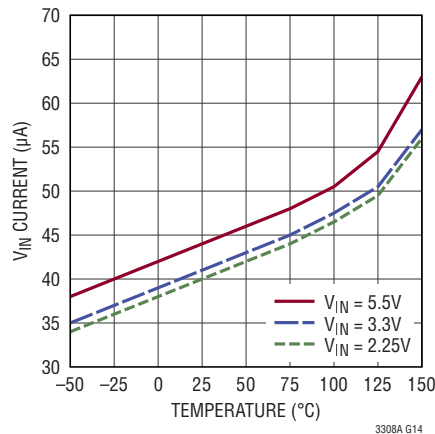

### $V_{IN}$ Quiescent Current All Modes, Not Sleeping

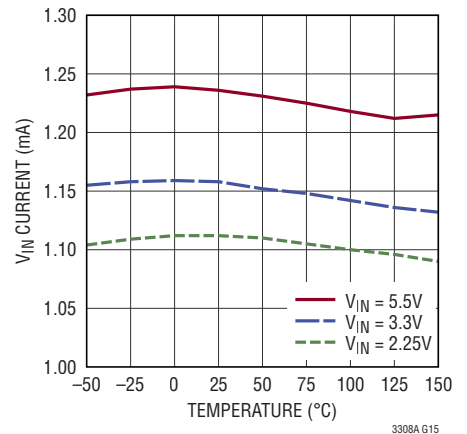

### Switch Leakage

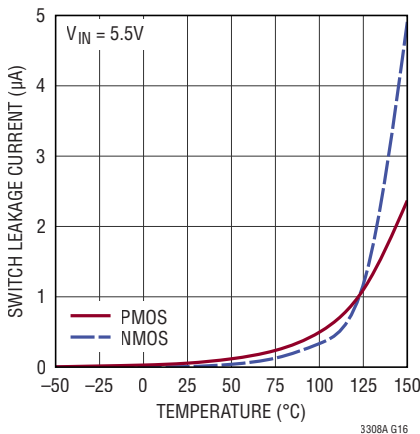

### EN Threshold

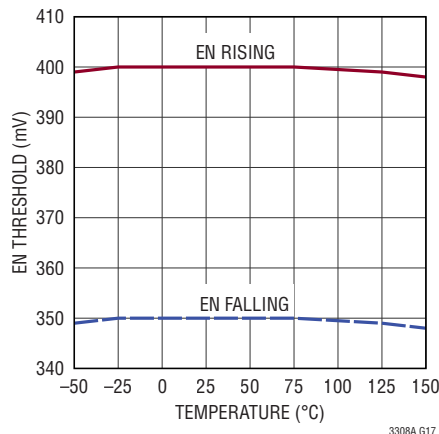

### $V_{IN}$ UVLO Threshold

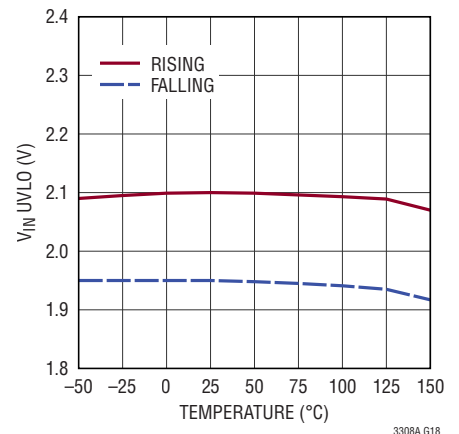

**TYPICAL PERFORMANCE CHARACTERISTICS**  $V_{IN} = 3.3V$ ,  $T_A = 25^\circ C$ , unless otherwise noted.

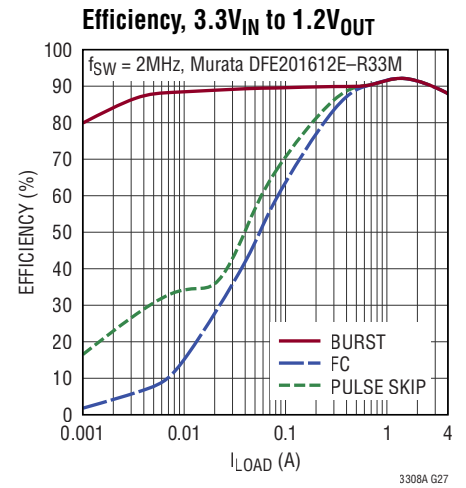
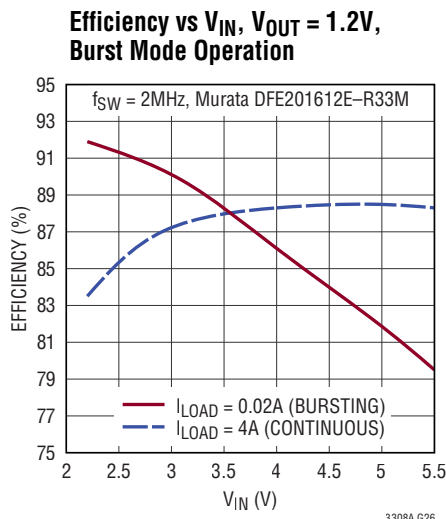
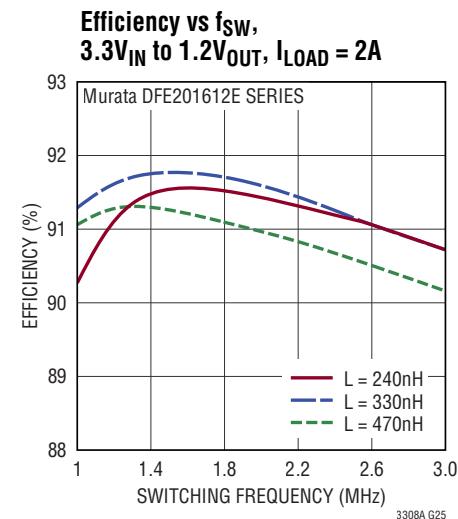
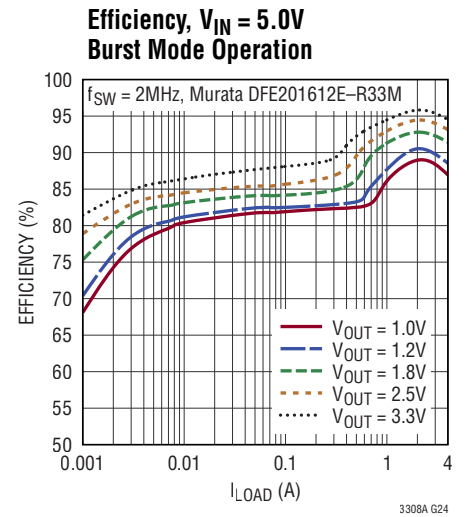
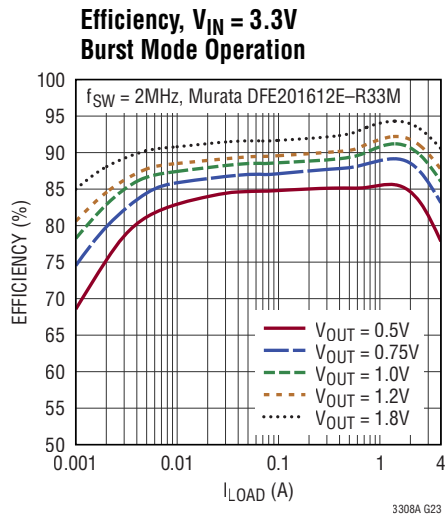
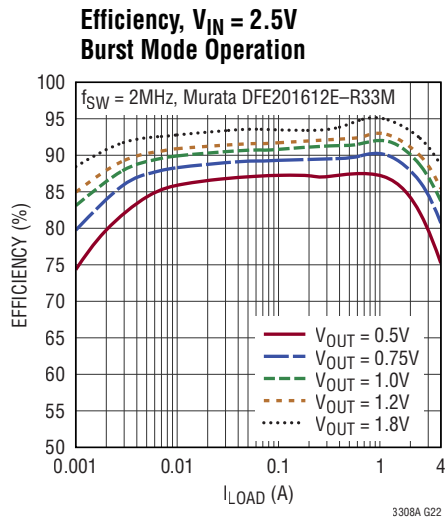
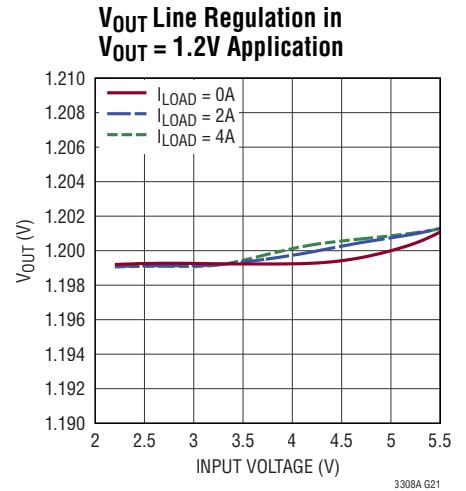
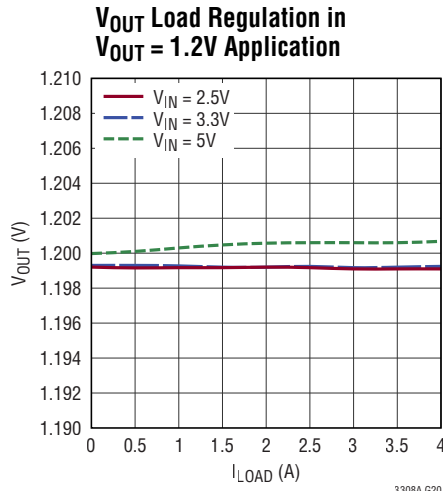
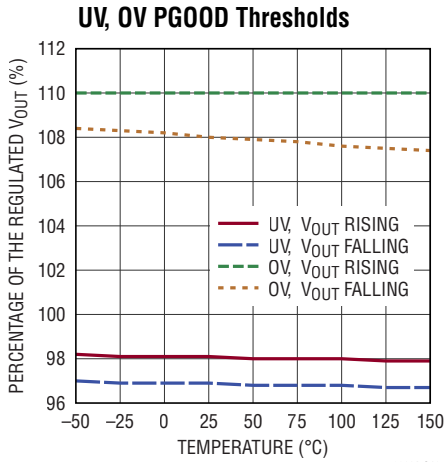

## TYPICAL PERFORMANCE CHARACTERISTICS $V_{IN} = 3.3V$ , $T_A = 25^\circ C$ , unless otherwise noted.

**Start-Up Waveforms, Forced Continuous Mode**

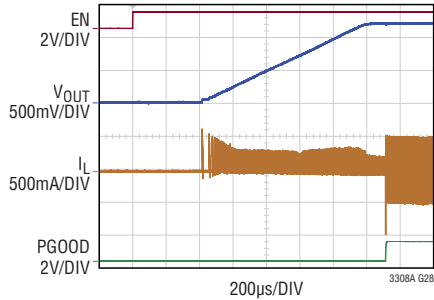

3.3V<sub>IN</sub> to 1.2V<sub>OUT</sub>, 2MHz Typical Application  
R<sub>LOAD</sub> = 120Ω

**Start-Up Waveforms, Pulse Skip Mode**

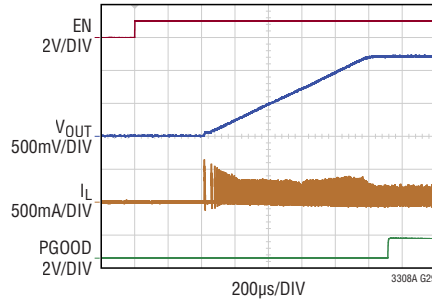

3.3V<sub>IN</sub> to 1.2V<sub>OUT</sub>, 2MHz Typical Application  
R<sub>LOAD</sub> = 120Ω

**Start-Up Waveforms, Burst Mode Operation**

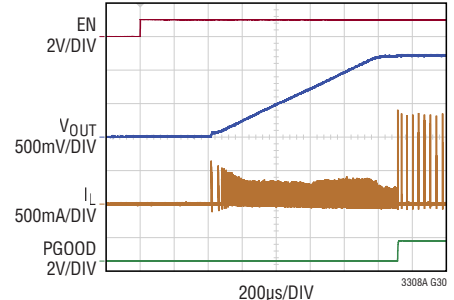

3.3V<sub>IN</sub> to 1.2V<sub>OUT</sub>, 2MHz Typical Application  
R<sub>LOAD</sub> = 120Ω

**Switching Waveforms, Forced Continuous Mode**

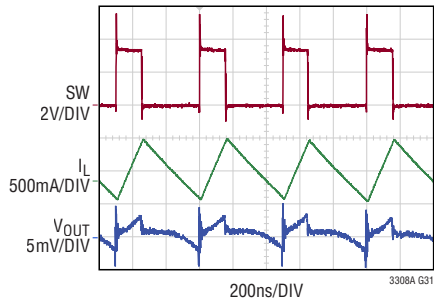

3.3V<sub>IN</sub> to 1.2V<sub>OUT</sub>, 2MHz Typical Application  
C<sub>OUT</sub> = 44µF, L = 330nH, I<sub>LOAD</sub> = 500mA

**Switching Waveforms, Pulse Skip Mode**

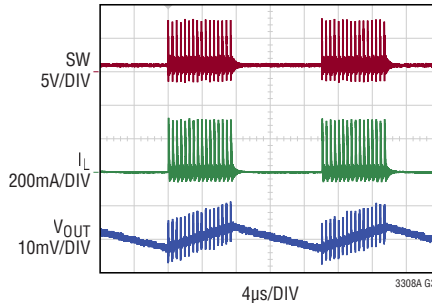

5.0V<sub>IN</sub> to 1.2V<sub>OUT</sub>, 2MHz Application  
C<sub>OUT</sub> = 44µF, L = 330nH, I<sub>LOAD</sub> = 2mA

**Switching Waveforms, Burst Mode Operation**

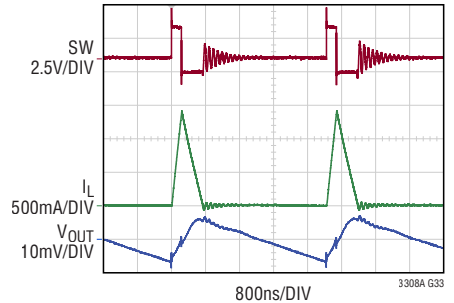

3.3V<sub>IN</sub> to 1.2V<sub>OUT</sub>, 2MHz Typical Application  
C<sub>OUT</sub> = 44µF, L = 330nH, I<sub>LOAD</sub> = 100mA

**Load Transient Response, Forced Continuous Mode**

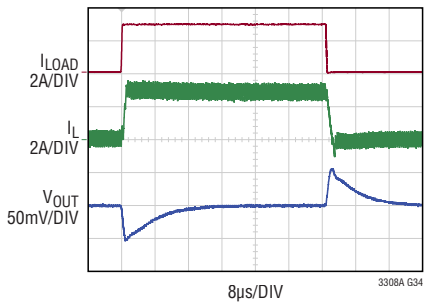

3.3V<sub>IN</sub> to 1.2V<sub>OUT</sub>, 2MHz Typical Application  
C<sub>OUT</sub> = 44µF, L = 330nH  
LOAD STEP: 50mA TO 3A (10A/µs)

**Load Transient Response, Pulse Skip Mode**

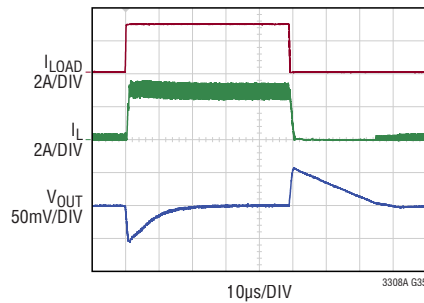

3.3V<sub>IN</sub> to 1.2V<sub>OUT</sub>, 2MHz Typical Application  
C<sub>OUT</sub> = 44µF, L = 330nH  
LOAD STEP: 50mA TO 3A (10A/µs)

**Load Transient Response, Burst Mode Operation**

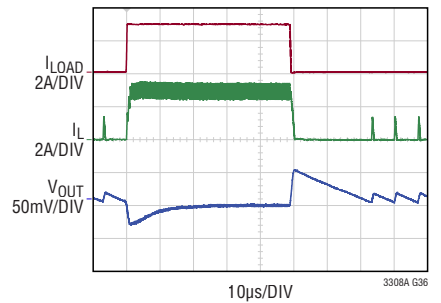

3.3V<sub>IN</sub> to 1.2V<sub>OUT</sub>, 2MHz Typical Application  
C<sub>OUT</sub> = 44µF, L = 330nH  
LOAD STEP: 50mA TO 3A (10A/µs)



## PIN FUNCTIONS

**AGND (Pin 1):** The AGND pin is the output voltage remote ground sense. Connect the AGND pin directly to the negative terminal of the output capacitor at the load. The AGND pin is also the ground reference for the internal analog circuitry. Place a small analog bypass 0201 or 0402 ceramic capacitor as close as possible to the  $V_{IN}$  (Pin 3) and AGND pins. Connect RT and FB returns to AGND as well.

**EN (Pin 2):** The EN pin has a precision IC enable threshold with hysteresis. An external resistor divider, from  $V_{IN}$  or from another supply, can be used to program the threshold below which the LTC3308A will shut down. If the precision threshold is not required, tie EN directly to  $V_{IN}$ . When the EN pin is low the LTC3308A enters a low current shutdown mode where all internal circuitry is disabled. Do not float this pin.

**$V_{IN}$  (Pins 3, 8):** The  $V_{IN}$  pins supply current to internal circuitry and topside power switch. Connect both  $V_{IN}$  pins together with short wide traces and bypass to PGND and AGND with low ESR capacitors located as close as possible to the pins.

**PGND (Pins 4, 7, Exposed Pad Pin 13):** The PGND pins are the return path of the internal bottom side power switch. Connect the negative terminal of the input capacitors as close to the PGND pins as possible. For low parasitic inductance and good thermal performance, connect Pin 4 and Pin 7 to a large continuous ground plane on the printed circuit board directly under the LTC3308A. The PGND exposed pad is the main electrical and thermal highway and should be connected to large PCB ground plane(s) with many vias.

**SW (Pins 5, 6):** The SW pins are the switching outputs of the internal power switches. Connect these pins together and to the inductor with a short, wide trace.

**MODE/SYNC (Pin 9):** The MODE/SYNC pin is a mode selection and external clock synchronization input. Ground this pin to enable Pulse Skip mode at light loads. For higher efficiency at light loads, tie this pin to  $V_{IN}$  to enable the low-ripple Burst Mode operation. For faster transient response, lower noise and full frequency operation over a wide load range, float this pin to enable forced continuous mode. Drive MODE/SYNC with an external clock to synchronize the switcher to the applied frequency. While synchronizing, the part operates in the forced continuous mode. The slope compensation is automatically adapted to the external clock frequency. In the absence of an external clock the switching frequency is determined by the RT pin.

**RT (Pin 10):** The RT pin sets the switching frequency with an external resistor to AGND. If this pin is tied to  $V_{IN}$ , the buck will switch at the default oscillator frequency. If the external clock is driving the MODE/SYNC pin, the RT pin is ignored.

**PGOOD (Pin 11):** The PGOOD pin is the open drain output of an internal power good comparator. When the regulated output voltage falls below the PGOOD threshold or rises above the overvoltage threshold, this pin is pulled low. When  $V_{IN}$  is above  $V_{IN}$  UVLO and the part is in shutdown, this pin is also pulled low.

**FB (Pin 12):** Program the output voltage and close the control loop by connecting this pin to the middle node of a resistor divider between the  $V_{OUT}$  and AGND. The LTC3308A regulates FB to 500mV (typical). A phase lead capacitor connected between FB and  $V_{OUT}$  may be used to optimize transient response.

## BLOCK DIAGRAM

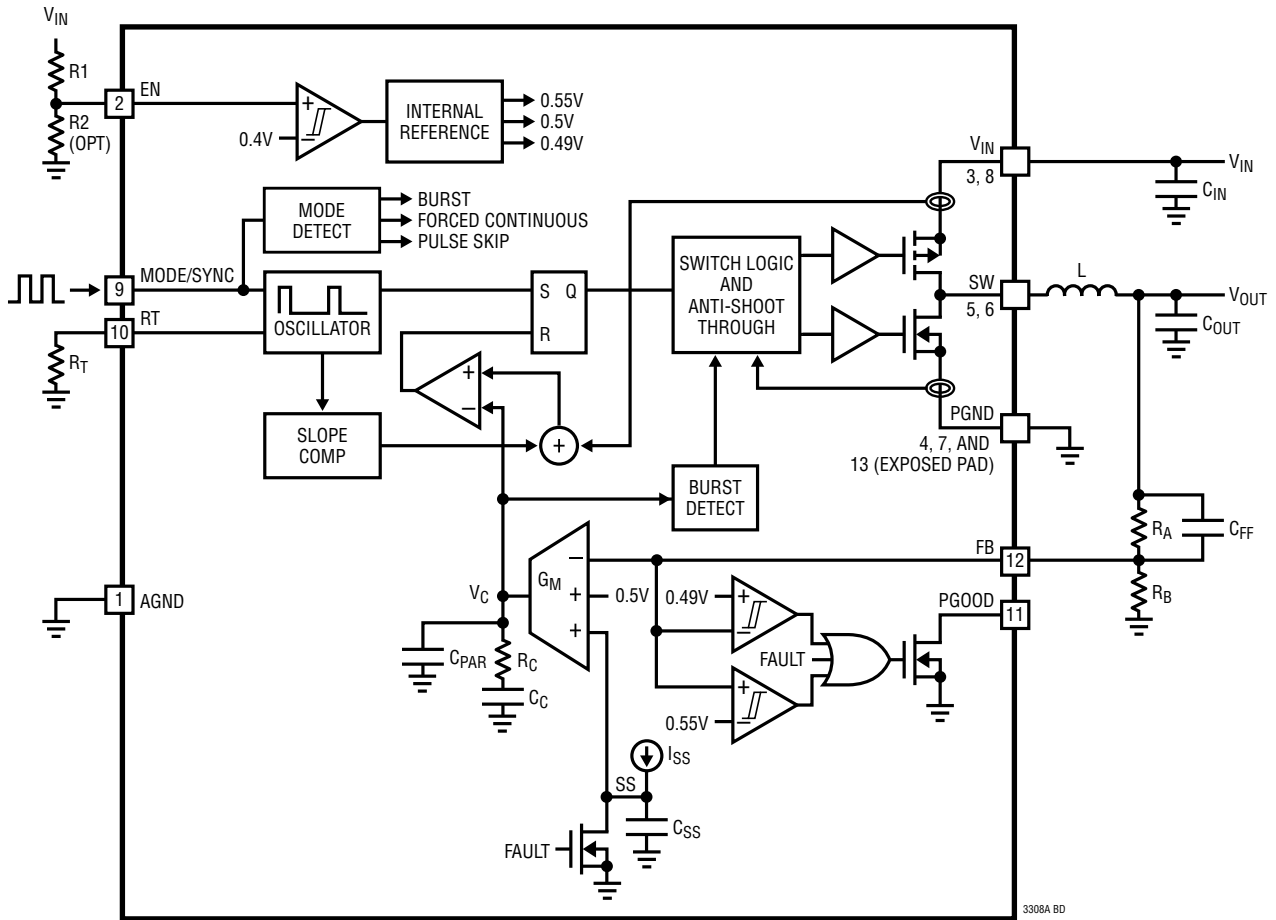

3308A BD

## OPERATION

### Voltage Regulation

The LTC3308A is a 5V, 4A monolithic, constant frequency, peak current mode control, step-down DC/DC converter. The synchronous buck switching regulators are internally compensated and require only external feedback resistors to set the output voltage. An internal oscillator, with the frequency set using a resistor on the RT pin or synchronized to an external clock, turns on the internal top power switch at the beginning of each clock cycle. Current in the inductor ramps up until the top switch current comparator trips and turns off the top power switch. The peak inductor current at which the top switch turns off is controlled by an internal  $V_C$  voltage. The error amplifier regulates  $V_C$  by comparing the voltage on the FB pin with an internal 500mV reference. An increase in the load current causes a reduction in the feedback voltage relative to the reference, causing the error amplifier to raise the  $V_C$  voltage until the average inductor current matches the new load current. When the top power switch turns off, the synchronous power switch turns on and ramps down the inductor current for the remainder of the clock cycle or, in pulse skip or Burst mode, until the inductor current falls to zero. If an overload condition results in excessive current flowing through the bottom switch, the next clock cycle will be skipped until switch current returns to a safe level.

The enable pin has a precision 400mV threshold to provide event-based power-up sequencing by connecting the EN pin to the output of another buck through a resistor divider. If the EN pin is low, the device is shut down and in a low quiescent current state. When the EN pin is above its threshold, the switching regulator will be enabled.

The LTC3308A has forward and reverse inductor current limiting, short-circuit protection, output over-voltage protection, and soft-start to limit inrush current during start-up or recovery from a short-circuit.

### Mode Selection

The LTC3308A operates in three different modes set by the MODE/SYNC pin: pulse skip mode (when the MODE/SYNC pin is set low), forced continuous mode (when the MODE/SYNC pin is floating) and Burst Mode operation (when the MODE/SYNC pin is set high).

In pulse skip mode, the oscillator operates continuously and positive SW transitions are aligned to the clock. Negative inductor current is disallowed and, during light loads, switch pulses are skipped to regulate the output voltage.

In forced continuous mode, the oscillator operates continuously. The top switch turns on every cycle and regulation is maintained by allowing the inductor current to reverse at light load. This mode allows the buck to run at a fixed frequency with minimal output ripple. In forced continuous mode, if the inductor current reaches  $I_{REVMAX}$  (into the SW pin), the bottom switch will turn off for the remainder of the cycle to limit the current.

In Burst Mode operation at light loads, the output capacitor is charged to a voltage slightly higher than its regulation point. The regulator then goes into a sleep state, during which time the output capacitor provides the load current. In sleep, most of the regulator's circuitry is powered down, helping conserve input power. When the output voltage drops below its programmed value, the circuitry is powered on and another burst cycle begins. The sleep time decreases as load current increases. In Burst Mode operation, the regulator will burst at light loads whereas at higher loads it will operate in constant frequency PWM mode.

## OPERATION

### Synchronizing the Oscillator to an External Clock

The LTC3308A's internal oscillator can be synchronized through an internal PLL circuit to an external frequency by applying a square wave clock signal to the MODE/SYNC pin.

During synchronization, the top power switch turn-on is locked to the rising edge of the external frequency source. While synchronizing, the switcher operates in forced continuous mode. The slope compensation is automatically adapted to the external clock frequency. The synchronization frequency range is 1MHz to 3MHz.

After detecting an external clock on the first rising edge of the MODE/SYNC pin, the internal PLL gradually adjusts its operating frequency to match the frequency and phase of the signal on the MODE/SYNC pin. When the external clock is removed, the LTC3308A will detect the absence of the external clock within approximately 10 $\mu$ s. During this time, the PLL will continue to provide clock cycles. Once the external clock removal has been detected, the oscillator will gradually adjust its operating frequency to the one programmed by the RT pin.

### Output Power Good

When the LTC3308A's output voltage is within the  $-2\%/+10\%$  window of the nominal regulation voltage the output is considered good and the open-drain PGOOD pin goes high impedance and is typically pulled high with an external resistor. Otherwise, the internal pull-down device will pull the PGOOD pin low. The PGOOD pin is also pulled low during the following fault conditions: EN pin is low,  $V_{IN}$  is too low or thermal shutdown. To filter noise and short duration output voltage transients, the lower threshold has a hysteresis of 1.2%, the upper threshold has a hysteresis of 2.2%, and both have a built-in time delay to report PGOOD, typically 120 $\mu$ s.

### Output Overvoltage Protection

During an output overvoltage event, when the FB pin voltage is greater than 110% of nominal, the LTC3308A top power switch will be turned off. If the output remains out of regulation for more than 120 $\mu$ s, the PGOOD pin will be pulled low.

An output overvoltage event should not happen under normal operating conditions.

### Overtemperature Protection

To prevent thermal damage to the LTC3308A and its surrounding components, the device incorporates an overtemperature (OT) function. When the die temperature reaches 165°C (typical, not tested) the switcher is shut down and remains in shutdown until the die temperature falls to 160°C (typical, not tested).

### Output Voltage Soft-Start

Soft starting the output prevents current surge on the input supply and/or output voltage overshoot. During the soft-start, the output voltage will proportionally track the internal node voltage ramp. An active pull-down circuit discharges that internal node in the case of fault conditions. The ramp will restart when the fault is cleared. Fault conditions that initiate the soft-start ramp are the EN pin transitioning low,  $V_{IN}$  voltage falling too low, or thermal shutdown.

### Dropout Operation

As the input supply voltage approaches the output voltage, the duty cycle increases toward 100%. Further reduction of the supply voltage forces the main switch to remain on for more than one cycle, eventually reaching 100% duty cycle. The output voltage will then be determined by the input voltage minus the DC voltage drop across the internal P-channel MOSFET and the inductor.

## Low Supply Operation

The LTC3308A is designed to operate down to an input supply voltage of 2.25V. One important consideration at low input supply voltages is that the  $R_{DS(ON)}$  of the internal power switches increases. Calculate the worst case LTC3308A power dissipation and die junction temperature at the lowest input voltages.

## Output Short-Circuit Protection and Recovery

The peak inductor current level, at which the current comparator shuts off the top power switch, is controlled by the internal  $V_C$  voltage. When the output current increases, the error amplifier raises  $V_C$  until the average inductor current matches the load current. The LTC3308A clamps the maximum  $V_C$  voltage, thereby limiting the peak inductor current.

When the output is shorted to ground, the inductor current decays very slowly when the bottom power switch is on because the voltage across the inductor is low. To keep the inductor current in control, a secondary limit is imposed on the valley of the inductor current. If the inductor current measured through the bottom power switch remains greater than  $I_{VALLEYMAX}$  at the end of the cycle, the top power switch will be held off. Subsequent switching cycles will be skipped until the inductor current falls below  $I_{VALLEYMAX}$ .

Recovery from an output short circuit may involve a soft-start cycle if  $V_{FB}$  falls more than approximately 100mV below regulation. During such a recovery,  $V_{FB}$  will quickly charge up by that ~100mV and then follow the soft-start ramp until regulation is reached.

## APPLICATIONS INFORMATION

Refer to the Block Diagram for reference.

### Output Voltage and Feedback Network

The output voltage is programmed by a resistor divider between the output and the FB pin. Choose the resistor values according to:

$$R_A = R_B \left( \frac{V_{OUT}}{500mV} - 1 \right) \quad (1)$$

as shown in Figure 1:

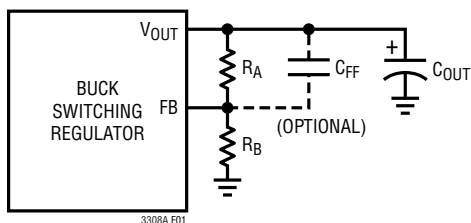

Figure 1. Feedback Resistor Network

Reference designators refer to the Block Diagram. Typical values for  $R_B$  range from 40k $\Omega$  to 400k $\Omega$ . 0.1% resistors are recommended to maintain output voltage accuracy. The buck regulator transient response may improve with an optional phase lead capacitor  $C_{FF}$  that helps cancel the pole created by the feedback resistors and the input capacitance of the FB pin. Experimentation with capacitor values between 2pF and 22pF may improve transient response. The values used in the typical application circuits are a good starting point.

### Operating Frequency Selection and Trade-Offs

Selection of the operating frequency is a trade-off between efficiency, component size, transient response and input voltage range.

The advantage of high frequency operation is that smaller inductor and capacitor values may be used. Higher switching frequencies allow for higher control loop bandwidth and, therefore, faster transient response. The

## APPLICATIONS INFORMATION

disadvantages of higher switching frequencies are lower efficiency, because of increased switching losses, and a smaller input voltage range, because of minimum switch on-time limitations.

The minimum on-time of the buck regulator imposes a minimum operating duty cycle. The highest switching frequency ( $f_{SW(MAX)}$ ) for a given application can be calculated as follows:

$$f_{SW(MAX)} = \frac{V_{OUT}}{t_{ON(MIN)} \cdot V_{IN(MAX)}} \quad (2)$$

where  $V_{IN(MAX)}$  is the maximum input voltage,  $V_{OUT}$  is the output voltage and  $t_{ON(MIN)}$  is the minimum top switch on-time. This equation shows that a slower switching frequency is necessary to accommodate a high  $V_{IN(MAX)}/V_{OUT}$  ratio.

The LTC3308A is capable of a maximum duty cycle of 100%, therefore, the  $V_{IN}$ -to- $V_{OUT}$  dropout is limited by the  $R_{DS(ON)}$  of the top switch, the inductor DCR and the load current.

### Setting the Switching Frequency

The LTC3308A uses a constant frequency peak current mode control architecture. There are three methods to set the switching frequency.

The first method, connecting the RT pin to  $V_{IN}$ , sets the switching frequency to the internal default with a nominal value of 2MHz.

The second method is with a resistor ( $R_T$ ) tied from the RT pin to ground. The frequency can be programmed from 1MHz to 3MHz. Table 1 and the Equation 3 show the necessary  $R_T$  value for a desired switching frequency:

$$R_T = \frac{73.4}{f_{SW}} - 1.9 \quad (3)$$

where  $R_T$  is in  $k\Omega$  and  $f_{SW}$  is the desired switching frequency in MHz, ranging from 1MHz to 3MHz.

**Table 1.  $R_T$  Value vs Switching Frequency**

$f_{SW}$ (MHz)	$R_T$ ( $k\Omega$ )
1.0	71.5
1.2	59.0
1.4	49.9
1.6	43.2
1.8	38.3
2.0	34.8
2.2	30.9
2.4	28.7
2.6	26.1
2.8	24.3
3.0	22.6

The third method to set the switching frequency is by synchronizing the internal PLL circuit to an external square wave clock applied to the MODE/SYNC pin. The synchronization frequency range is 1MHz to 3MHz. The square wave amplitude should have valleys that are below 0.4V and peaks above 1.2V. High and low pulse widths should both be at least 40ns.

### Inductor Selection and Maximum Output Current

Considerations in choosing an inductor are inductance, RMS current rating, saturation current rating, DCR and core loss.

Select the inductor value based on the following equation:

$$L \approx \frac{V_{OUT}}{1.2A \cdot f_{SW}} \cdot \left( 1 - \frac{V_{OUT}}{V_{IN(MAX)}} \right) \text{ for } \frac{V_{OUT}}{V_{IN(MAX)}} \leq 0.5 \quad (4)$$

$$L \approx \frac{0.25 \cdot V_{IN(MAX)}}{1.2A \cdot f_{SW}} \text{ for } \frac{V_{OUT}}{V_{IN(MAX)}} > 0.5 \quad (5)$$

where  $f_{SW}$  is the switching frequency,  $V_{IN(MAX)}$  is the maximum input voltage.

To avoid overheating of the inductor choose an inductor with an RMS current rating that is greater than the maximum expected output load of the application. Overload and short-circuit conditions need to be taken into consideration.



## APPLICATIONS INFORMATION

In addition, ensure that the saturation current rating (typically labeled  $I_{SAT}$ ) of the inductor is higher than the maximum expected load current plus half the inductor ripple current:

$$I_{SAT} > I_{LOAD(MAX)} + \frac{1}{2} \Delta I_L \quad (6)$$

where  $I_{LOAD(MAX)}$  is the maximum output load current for a given application and  $\Delta I_L$  is the inductor ripple current calculated as:

$$\Delta I_L = \frac{V_{OUT}}{L \cdot f_{SW}} \cdot \left( 1 - \frac{V_{OUT}}{V_{IN}} \right) \quad (7)$$

A more conservative choice would be to use an inductor with an  $I_{SAT}$  rating higher than the maximum current limit of the LTC3308A.

To keep the efficiency high, choose an inductor with the lowest series resistance (DCR). The core material should be intended for high frequency applications. Table 2 shows recommended inductors from several manufacturers.

**Table 2. Recommended Inductors with Typical Specifications**

MANUFACTURER	INDUCTOR FAMILY	INDUCTANCE (nH)	$I_{TEMP}$ (A)*	$I_{SAT}$ (A)	DCR (m $\Omega$ )	W x L x H (mm)
Murata	DFE201210U	240	3.8	6.5	20	2.0 x 1.2 x 1.0
Murata	DFE201610E	240 to 470	5.5 to 4.2	7.0 to 5.3	16 to 26	2.0 x 1.6 x 1.0
Murata	DFE201612E	240 to 680	6.0 to 4.1	7.8 to 4.8	13 to 27	2.0 x 1.6 x 1.2
Murata	DFE252010F	330, 470	5.6, 4.4	7.6, 6.0	16, 27	2.5 x 2.0 x 1.0
Murata	DFE252012F	330 to 680	6.0 to 4.6	8.5 to 6.0	14 to 25	2.5 x 2.0 x 1.2
Vishay	IHHP-0806AB-01	220 to 470	5.3 to 4.2	5.8 to 4.4	13 to 29	2.0 x 1.6 x 1.2
Vishay	IHHP-1008AB-01	220 to 470	7.4 to 4.5	7.1 to 5.05	8.4 to 21	2.5 x 2.0 x 1.2
NIC	NPMH0805B	240	4.2	4.8	25 (max)	2.0 x 1.2 x 0.8
NIC	NPMH0806C	240, 330	3.9, 4.7	5.6, 5.3	27, 23 (max)	2.0 x 1.6 x 1.0
NIC	NPIM26LP	240 to 680	6.5 to 4.2	7.5 to 5.1	15 to 36	2.0 x 1.6 x 1.0
NIC	NPIM20LP	240 to 680	6.0 to 4.4	9.5 to 5.5	18 to 32	2.5 x 2.0 x 1.0
Sumida	201610CDMCD/DS	240 to 680	6.3 to 4.2	7.2 to 4.2	16 to 36	2.2 x 1.8 x 1.0
Sumida	252010CDMCD/DS	470 to 1000	6.0 to 4.0	6.1 to 4.0	17 to 40	2.7 x 2.2 x 1.0
Sumida	252012CDMCD/DS	470 to 1000	6.1 to 4.2	7.3 to 5.4	17 to 35	2.7 x 2.2 x 1.2
Cyntec	HMLQ20161T	330, 470	4.8, 4.4	5.7, 4.9	21, 26	2.0 x 1.6 x 1.0
Cyntec	HTEK20161T	470, 1000	5.4, 4.5	6.0, 4.6	18, 35	2.0 x 1.6 x 1.0
Cyntec	HMLB25201T	220	5.9	7.0	9.4	2.5 x 2.0 x 1.0
Cyntec	HMLQ25201T	330, 470	5.5, 4.3	7.3, 5.6	16, 19	2.5 x 2.0 x 1.0
Cyntec	HMLQ25201B	330 to 1000	6.4 to 4.0	7.5 to 4.5	14 to 34	2.5 x 2.0 x 1.2
XFRMS	XFHCL43LT	220, 330	8.0, 5.6	7.0, 4.3	13 to 17 (max)	2.5 x 2.0 x 1.2
Würth Elektronik	WE-LQS-2512	160	3.7	6.4	16	2.5 x 2.0 x 1.2
Murata	DFE201612PD-R15M	150	5.2	6.2	12	2.0 x 1.6 x 1.2
TDK	TFM201208BLD	110	6.8	8.8	10	2.0 x 1.2 x 0.8

\*Strongly depends on the PCB thermal properties

## APPLICATIONS INFORMATION

### Input Capacitors

Bypass the input of the LTC3308A with at least two ceramic capacitors close to the part, one on each side from  $V_{IN}$  to PGND, for best performance. These capacitors should be 0603 or 0805 in size. Smaller, optional 0201 capacitors can also be placed as close as possible to the LTC3308A directly on the traces leading from  $V_{IN}$  (Pin 3) and PGND (Pin 4) and on the traces leading from  $V_{IN}$  (Pin 8) and PGND (Pin 7) for better performance with minimal (if at all) increase in application footprint. See the layout section for more detail. X7R or X5R capacitors are recommended for best performance across temperature and input voltage variations (see Table 3). Note that larger input capacitance is required when a lower switching frequency is used. If the input power source has high impedance, or there is significant inductance due to long wires or cables, additional bulk capacitance may be necessary. This can be provided with an electrolytic capacitor.

A ceramic input capacitor combined with trace or cable inductance forms a high quality (under damped) tank circuit. If the LTC3308A circuit is plugged into a live supply, the input voltage can ring to twice its nominal value, possibly exceeding the LTC3308A's voltage rating. This situation is easily avoided (see Application Note [AN88](#)).

**Table 3. Ceramic Capacitor Manufacturers**

VENDOR	URL
AVX	<a href="http://www.avxcorp.com">www.avxcorp.com</a>
Murata	<a href="http://www.murata.com">www.murata.com</a>
TDK	<a href="http://www.tdk.com">www.tdk.com</a>
Taiyo Yuden	<a href="http://www.t-yuden.com">www.t-yuden.com</a>
Samsung	<a href="http://www.samsungsem.com">www.samsungsem.com</a>
Würth Elektronik	<a href="http://www.we-online.com">www.we-online.com</a>

### Output Capacitor, Output Ripple and Transient Response

The output capacitor has two essential functions. Along with the inductor, it filters the square wave generated by the LTC3308A at the SW pin to produce the DC output. In this role, it determines the output ripple; thus, low impedance at the switching frequency is important. The

second function is to store energy in order to satisfy transient loads and stabilize the LTC3308A's control loop. The LTC3308A is internally compensated and has been designed to operate at a high bandwidth for fast transient response capability. The selection of  $C_{OUT}$  affects the bandwidth of the system, but the transient response is also affected by  $V_{OUT}$ ,  $V_{IN}$ ,  $f_{SW}$  and other factors. A good place to start is with the output capacitance value of approximately:

$$C_{OUT} = 20 \cdot \frac{I_{MAX}}{f_{SW}} \sqrt{\frac{0.5}{V_{OUT}}} \quad (8)$$

where  $C_{OUT}$  is the recommended output capacitor value in  $\mu\text{F}$ ,  $f_{SW}$  is the switching frequency in MHz,  $I_{MAX} = 4\text{A}$  is the rated output current in Amps, and  $V_{OUT}$  is in Volts.

A lower value output capacitor saves space and cost but transient performance will suffer and loop stability must be verified.

Ceramic capacitors have very low equivalent series resistance (ESR) and provide the best output ripple and transient performance. Use X5R or X7R ceramic capacitors (see Table 3). Even better output ripple and transient performance can be achieved by using low-ESL reverse geometry or three-terminal ceramic capacitors.

During a load step, the output capacitor must instantaneously supply the current to support the load until the feedback loop increases the switch current enough to support the load. The time required for the feedback loop to respond is dependent on the compensation components and the output capacitor size. Typically, 3 to 4 cycles are required to respond to a load step, but only in the first cycle does the output drop linearly. Although affected by  $V_{OUT}$ ,  $V_{IN}$ ,  $f_{SW}$ ,  $t_{ON(MIN)}$ , the equivalent series inductance (ESL) of the output capacitor, and other factors, the output droop,  $V_{DROOP}$ , is usually about 3 times the linear drop of the first cycle:

$$V_{DROOP} = \frac{3 \cdot \Delta I_{OUT}}{C_{OUT} \cdot f_{SW}} \quad (9)$$

where  $\Delta I_{OUT}$  is the load step.



## APPLICATIONS INFORMATION

Transient performance and control loop stability can be improved with a higher  $C_{OUT}$  and/or the addition of a feedforward capacitor  $C_{FF}$  placed between  $V_{OUT}$  and FB. Capacitor  $C_{FF}$  provides phase lead compensation by creating a high frequency zero which improves the phase margin and the high-frequency response. The values used in the typical application circuits are a good starting point. LTpowerCAD® is a useful tool to help optimize  $C_{FF}$  and  $C_{OUT}$  for a desired transient performance.

Applying a load transient and monitoring the response of the system or using a network analyzer to measure the actual loop response are two ways to experimentally verify transient performance and control loop stability, and to optimize  $C_{FF}$  and  $C_{OUT}$ .

When using the load transient response method to stabilize the control loop apply an output current pulse of 20% to 100% of full load current having a very fast rise time. This will produce a transient on the output voltage. Monitor  $V_{OUT}$  for overshoot or ringing that might indicate a stability problem (see [Application Note AN149](#)).

### Output Voltage Sensing

The LTC3308A's AGND pin is the ground reference for the internal analog circuitry, including the bandgap voltage reference. To achieve good load regulation connect the AGND pin to the negative terminal of the output capacitor ( $C_{OUT}$ ) at the load. Any drop in the high current power ground return path will be compensated. The AGND node carries very little current and, therefore, can be a minimal size trace. Place a small analog bypass 0201 or 0402 ceramic capacitor as close as possible to the LTC3308A directly on the traces leading from  $V_{IN}$  (Pin 3) and AGND pin. All of the signal components, such as the FB resistor dividers and the  $R_T$  resistor, should be referenced to the AGND node. See the example PCB Layout for more information.

### Enable Threshold Programming

The LTC3308A has a precision threshold enable pin to enable or disable the switching. When forced low, the device enters a low current shutdown mode.

The rising threshold of the EN comparator is 400mV, with 50mV of hysteresis. The EN pin can be tied to  $V_{IN}$  if the shutdown feature is not used. Adding a resistor divider from  $V_{IN}$  to EN programs the LTC3308A to regulate the output only when  $V_{IN}$  is above a desired voltage (see Figure 2). Typically, this threshold,  $V_{IN(EN)}$ , is used in situations where the input supply is current limited, or has a relatively high source resistance. A switching regulator draws near constant power from its input source, so source current increases as source voltage drops. This looks like a negative resistance load to the source and can cause the source to current limit or latch low under low source voltage conditions. The  $V_{IN(EN)}$  threshold prevents the regulator from operating at source voltages where problems may occur. This threshold can be adjusted by setting the values R1 and R2 such that they satisfy the following equation:

$$V_{IN(EN)} = \left( \frac{R1}{R2} + 1 \right) \cdot 400\text{mV} \quad (10)$$

as shown in Figure 2:

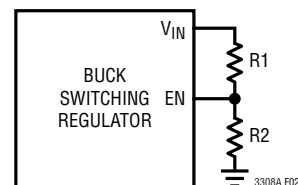

**Figure 2. EN Divider**

The LTC3308A will remain off until  $V_{IN}$  is above  $V_{IN(EN)}$ . The buck regulator will remain enabled until  $V_{IN}$  falls to  $0.875 \cdot V_{IN(EN)}$  and EN is 350mV typical.

Alternatively, a resistor divider from an output of an upstream regulator to the EN pin of the LTC3308A provides event-based power-up sequencing, enabling the LTC3308A when the output of the upstream regulator reaches a predetermined level (e.g. 90% of the regulated output). Replace  $V_{IN(EN)}$  in Equation 10 with that predetermined level.

## APPLICATIONS INFORMATION

### Low EMI PCB Layout

The LTC3308A is specifically designed to minimize EMI/EMC emissions and also to maximize efficiency and improve transient response when switching at high frequencies.

See Figure 3 for a recommended PCB layout.

For optimal performance the LTC3308A requires that both input supply  $V_{IN}$  pins (Pins 3, 8) each have a local decoupling capacitor with their ground terminals soldered directly to the ground plane on the top layer near PGND pins (Pins 4, 7). These capacitors provide the AC current to the internal power MOSFETs and their drivers. Large, switched currents flow in the  $V_{IN}$  and PGND pins and the input capacitors. The loops formed by the input capacitors should be as small as possible by placing the capacitors adjacent to the  $V_{IN}$  and PGND pins. Capacitors with small case size such as 0603 are optimal due to lowest parasitic inductance. Even smaller 0201 capacitors can additionally be placed right next to the respective  $V_{IN}$  and PGND pins for better performance with minimal (if at all) increase in

application footprint. In addition, place a local, unbroken ground plane under the application circuit on the layer closest to the surface layer.

Decoupling AGND is also very important. Place a small analog bypass 0201 or 0402 capacitor as close as possible to the LTC3308A directly on the traces leading from  $V_{IN}$  (Pin 3) and AGND (Pin 1).

Place the inductor on the same side of the circuit board. The trace connecting SW pins (Pins 5, 6) to the inductor should be as short as possible to reduce radiated EMI and parasitic coupling.

Keep the FB and RT nodes small and far away or shielded from the noisy SW node.

In the recommended layout, five 5mil vias are used to provide the best conductivity to the GND plane within the EPAD. For layouts where 5mil vias are not allowed, it is recommended to use either four 8mil vias or a single (filled or tented) 12mil diameter via. Refer to the Thermal Via Design section of the [Application Notes for Thermally Enhanced Leaded Plastic Packages](#) document for more information on thermal via recommendations.

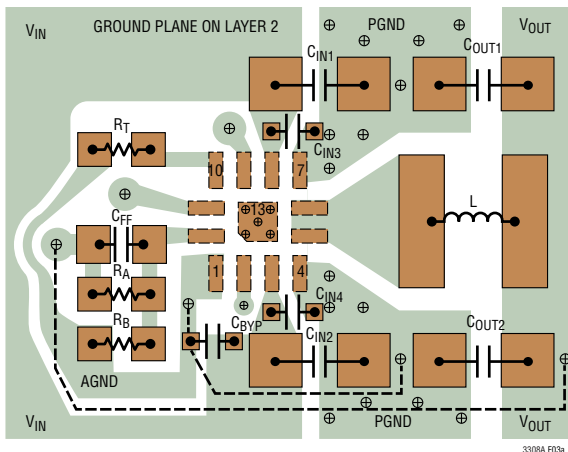

(a) Small Solution Size. Five 5mil Vias Are Used within the EPAD. For Layouts Where 5mil Vias Are Not Allowed, It Is Recommended to Use Either Four 8mil Vias or a Single (Filled or Tented) 12mil Diameter Via.

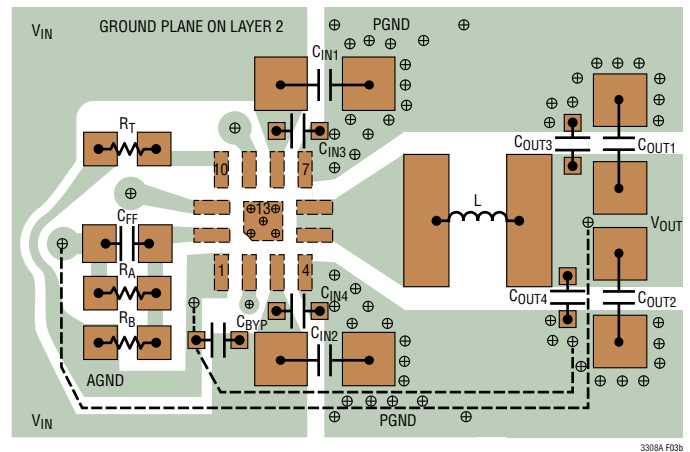

(b) With Capacitors  $C_{OUT1}$  and  $C_{OUT2}$  Rotated by  $90^\circ$ , Which Reduces High Frequency Output Ripple. Optional 0201 Capacitors  $C_{OUT3}$  and  $C_{OUT4}$  Further Improve the High Frequency Output Ripple. Five 5mil Vias Are Used within the EPAD. For Layouts Where 5mil Vias Are Not Allowed, It Is Recommended to Use Either Four 8mil Vias or a Single (Filled or Tented) 12mil Diameter Via.

Figure 3. Recommended PCB Layout for the LTC3308A

## APPLICATIONS INFORMATION

### High Temperature Considerations

Care should be taken in the layout of the PCB to ensure good heat sinking of the LTC3308A. Connect the exposed pad on the bottom of the package (Pin 13) to a large, unbroken ground plane under the application circuit on the layer closest to the surface layer. Place many vias to minimize thermal and electrical impedance. Solder the PGND pins (Pins 4, 7) directly to a ground plane on the top layer. Connect the top layer ground plane to ground plane(s) on lower levels with many thermal vias. These layers will spread heat dissipated by the LTC3308A. Figure 4 is a simplified thermal representation of a thermally enhanced LQFN package with exposed pad, with the silicon die and thermal metrics identified. The current source represents power loss  $P_D$  on the die; node voltages represent temperatures; electrical impedances represent conductive thermal impedances  $\theta_{JC\text{BOTTOM}}$ ,  $\theta_{JC\text{TOP}}$ ,  $\theta_{VIA}$ ,  $\theta_{CB}$ , and convective thermal impedances  $\theta_{BA}$  and  $\theta_{CA}$ . The junction temperature,  $T_J$ , is calculated from the ambient temperature,  $T_A$ , as:

$$T_J = T_A + P_D \cdot \theta_{JA} \quad (11)$$

where, neglecting the  $\theta_{JC\text{TOP}} + \theta_{CA}$  path:

$$\theta_{JA} \approx \theta_{JC\text{BOTTOM}} + \left( \frac{\theta_{CB} + \theta_{BA}}{2} \right) \parallel \left( \frac{\theta_{CB} + \theta_{BA}}{2} + \theta_{VIA} \right) \quad (12)$$

where  $\theta_{JC\text{BOTTOM}} = 8.6^\circ\text{C/W}$ . The value of  $\theta_{JA} = 51^\circ\text{C/W}$  reported in the Pin Configuration section corresponds to JEDEC standard 2S2P test PCB, which does not have good thermal vias, i.e.,  $\theta_{VIA}$  is relatively

high. Assuming, somewhat arbitrarily but not unrealistically, that  $\theta_{VIA} \sim (\theta_{CB} + \theta_{BA})/2$ , we back calculate  $(\theta_{CB} + \theta_{BA})/2 = \theta_{VIA} \approx 60^\circ\text{C/W}$  for such a board. The importance of thermal vias becomes clear once we observe that if the test PCB had low-thermal-resistance vias, the  $\theta_{JA}$  would have been reduced by up to  $10^\circ\text{C/W}$ , which is an improvement of up to 20%. Similarly, having more ground planes that are larger, uninterrupted and higher-copper-weight improves  $\theta_{CB} + \theta_{BA}$ , which has a dominant effect on  $\theta_{JA}$ , given the low value of  $\theta_{JC\text{BOTTOM}}$  of the package. See the Application Note, [Application Notes for Thermally Enhanced Leaded Plastic Packages](#), for the proper size and layout of the thermal vias and solder stencils. The maximum load current should be derated as the ambient temperature approaches the maximum junction rating. Power dissipation within the LTC3308A is estimated by calculating the total power loss from an efficiency measurement and subtracting the inductor loss.

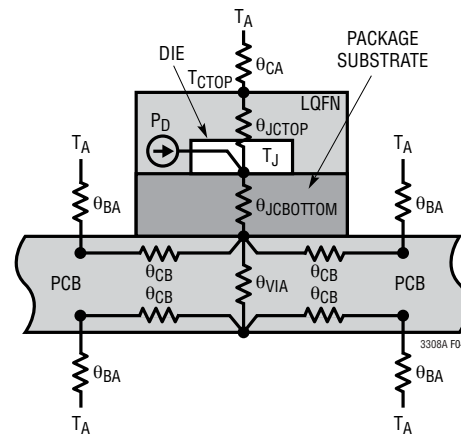
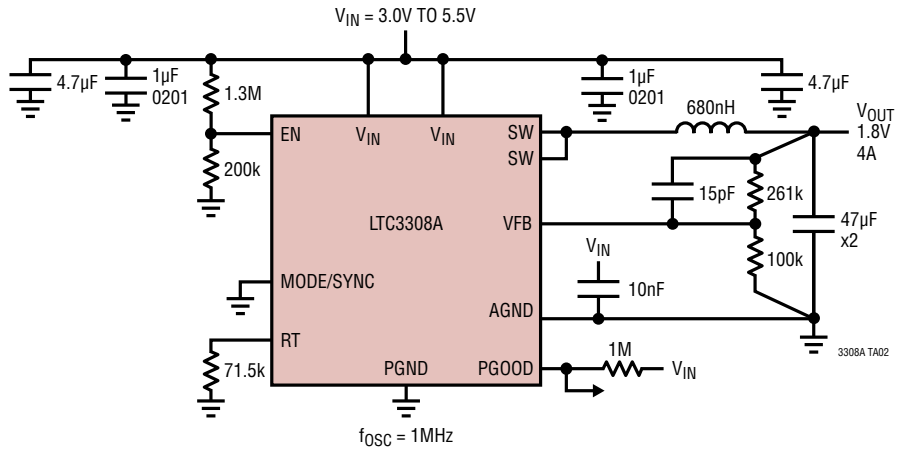

Figure 4. Multi-Layer PCB with Thermal Vias Acts as a Heat Sink

## TYPICAL APPLICATIONS

**V<sub>IN</sub> UVLO 3.0V, 1MHz, 1.8V, 4A, Pulse Skip Mode**



**Small Solution Size, 3MHz, 1.2V, 4A, Forced Continuous Mode**

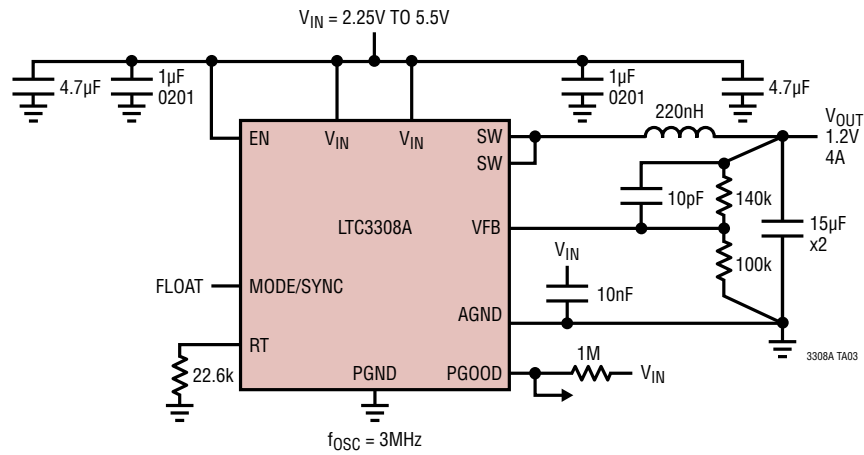

## TYPICAL APPLICATIONS

$V_{IN}$  UVLO 3.0V, 2.5V, 4A, Syncing to 1MHz, Forced Continuous Mode

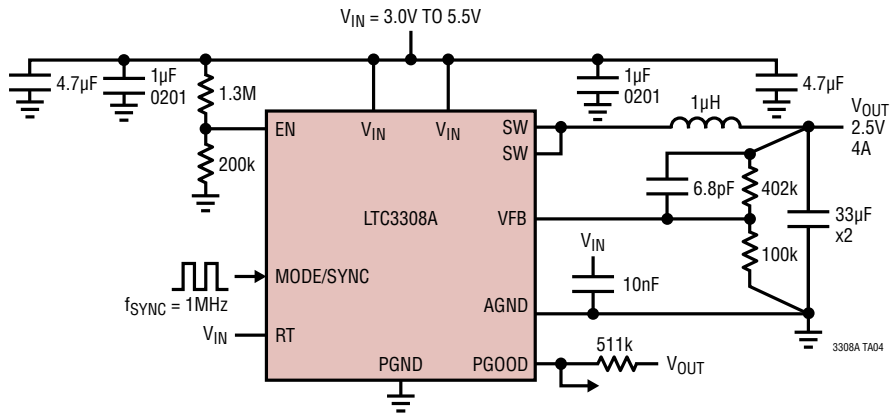

High Efficiency, 2MHz, 4A, 5V to 3.3V, Burst Mode Operation

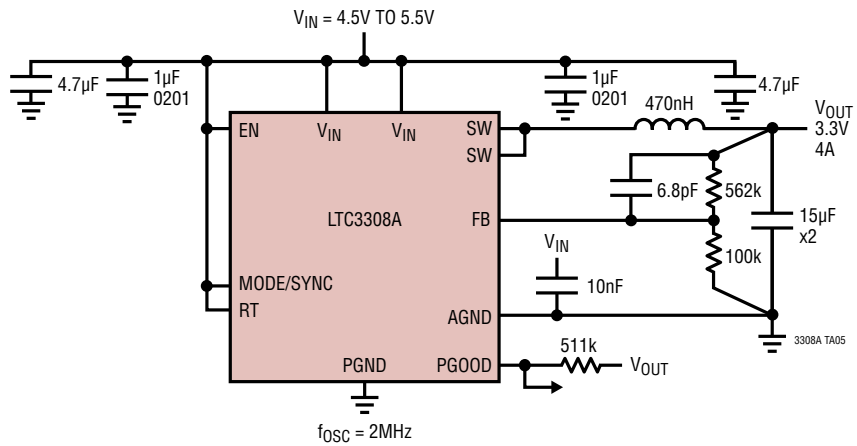

## TYPICAL APPLICATIONS

### High Efficiency, 2MHz, 4A, 2.5V, Burst Mode Operation

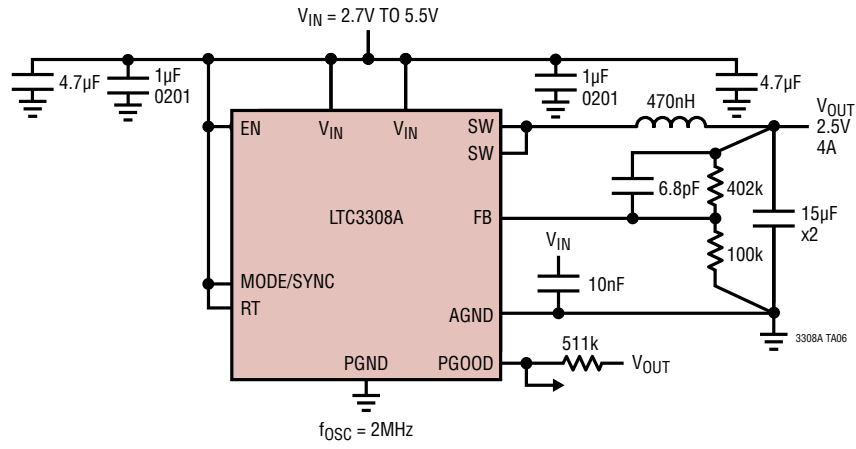

### High Efficiency, 2MHz, 4A, 1.8V, Burst Mode Operation

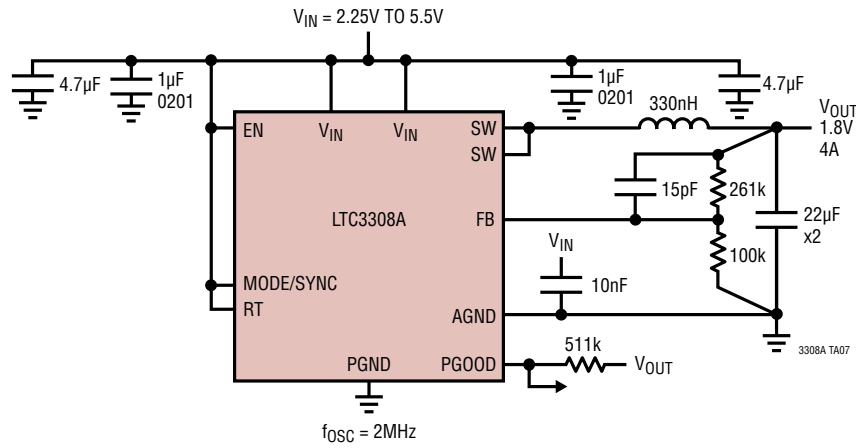

**TYPICAL APPLICATIONS**

**High Efficiency, 2MHz, 4A, 1.0V, Burst Mode Operation**

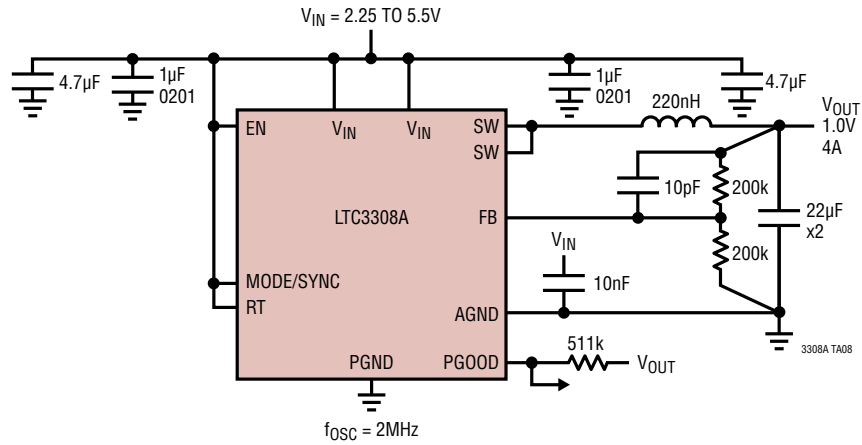

**High Efficiency, 2MHz, 4A, 0.75V, Burst Mode Operation**

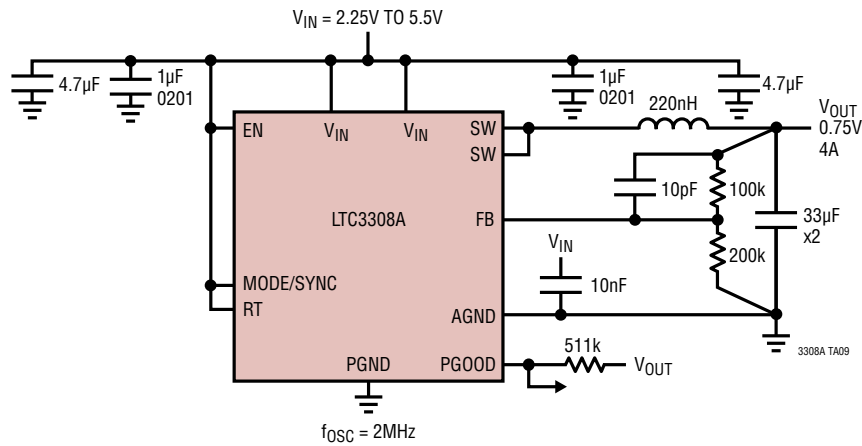

# PACKAGE DESCRIPTION

**LQFN Package**  
**12-Lead (2mm × 2mm × 0.74mm)**  
 (Reference LTC DWG # 05-08-1530 Rev B)

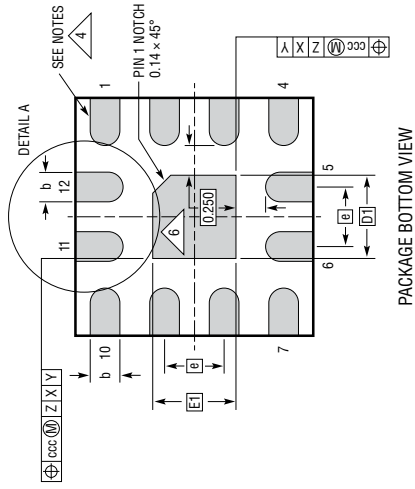

PACKAGE BOTTOM VIEW

- NOTES:**
1. DIMENSIONING AND TOLERANCING PER ASME Y14.5M-1994
  2. ALL DIMENSIONS ARE IN MILLIMETERS
  3. PRIMARY DATUM - Z - IS SEATING PLANE
  4. METAL FEATURES UNDER THE SOLDER MASK OPENING IN SO AS NOT TO OBSCURE THESE TERMINALS AND HEAT F
  5. DETAILS OF PIN 1 IDENTIFIER ARE OPTIONAL, BUT MUST LOCATED WITHIN THE ZONE INDICATED. THE PIN 1 IDENTIFIER MAY BE EITHER A MOLD OR MARKED FEATURE
  6. THE EXPOSED HEAT FEATURE MAY HAVE OPTIONAL CORN

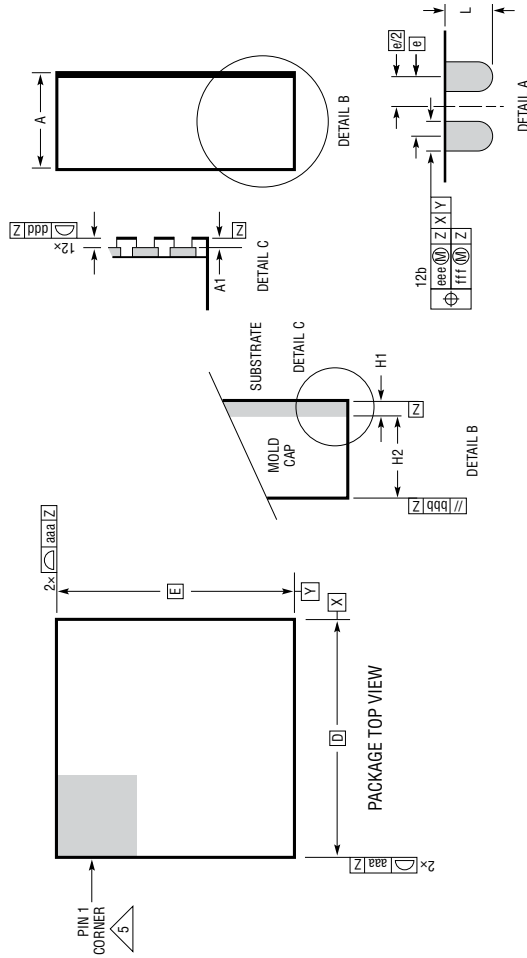

PACKAGE TOP VIEW

SYMBOL	MIN	NOM	MAX	NOTES
A	0.65	0.74	0.83	
A1	0.01	0.02	0.03	
L	0.30	0.40	0.50	
b	0.22	0.25	0.28	
D		2.00		
E		2.00		
D1		0.70		
E1		0.70		
e		0.50		
H1		0.24 REF		SUBSTRATE THK
H2		0.50 REF		MOLD CAP HT
aaa			0.10	
bbb			0.10	
ccc			0.10	
ddd			0.10	
eee			0.15	
fff			0.08	

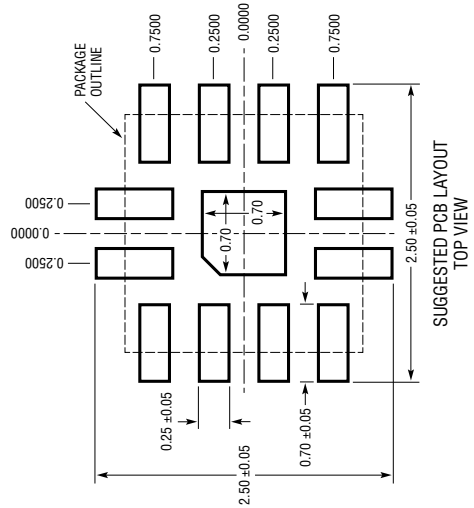

SUGGESTED PCB LAYOUT TOP VIEW

LQFN 12.0618 REV B



## REVISION HISTORY

REV	DATE	DESCRIPTION	PAGE NUMBER
A	01/21	Updated Feature list	1
		Added "Battery Powered Systems" to Applications list	1
		Corrected default conditions for Electrical Characteristics table	3
		Updated load and line regulation typical curves	7
		Corrected PGOOD upper threshold hysteresis typical value	12
		Changed inductor value equation to approximate value	14
		Updated Recommended Inductor table	15
		Added description of allowable modifications to EPAD vias	18
		Added mode of operation descriptors to all Typical Applications	21, 22, 23, 26
		Expanded allowed input voltages in Typical Applications	22, 23
		Updated Related Parts table	26

## TYPICAL APPLICATION

### High Efficiency, 2MHz, 0.5V, 4A, Burst Mode Operation

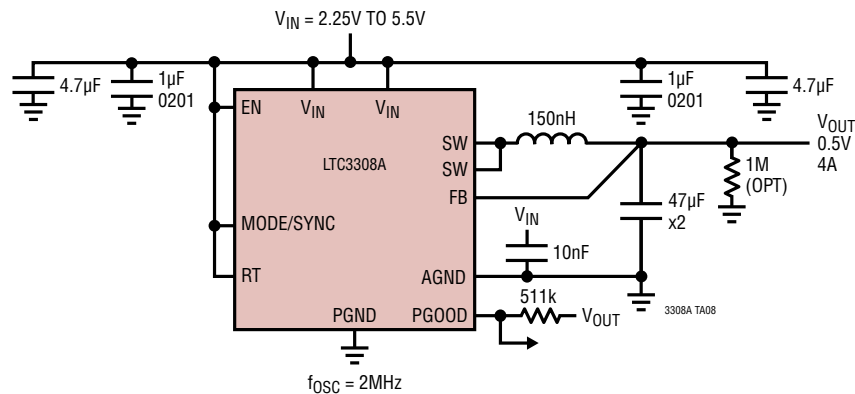

## RELATED PARTS

PART NUMBER	DESCRIPTION	COMMENTS
<a href="#">LTC3307A/</a> <a href="#">LTC3307B</a>	5V, 3A Synchronous Step-Down Silent Switcher in 2mm × 2mm LQFN	Monolithic Synchronous Step-Down DC/DC Capable of Supplying 3A at Switching Frequencies up to 3MHz/10MHz. Silent Switcher Architecture for Ultralow EMI Emissions. 2.25V to 5.5V Input Operating Range. 0.5V to $V_{IN}$ Output Voltage Range with ±1% Accuracy. PGOOD Indication, RT Programming, SYNC Input. 2mm × 2mm LQFN.
<a href="#">LTC3308B</a>	5V, 4A Synchronous Step-Down Silent Switcher in 2mm × 2mm LQFN	Monolithic Synchronous Step-Down DC/DC Capable of Supplying 4A at Switching Frequencies Up to 10MHz. Silent Switcher Architecture for Ultralow EMI Emissions. 2.25V to 5.5V Input Operating Range. 0.5V to $V_{IN}$ Output Voltage Range with ±1% Accuracy. PGOOD Indication, RT Programming, SYNC Input. 2mm × 2mm LQFN.
<a href="#">LTC3309A/</a> <a href="#">LTC3309B</a>	5V, 6A Synchronous Step-Down Silent Switcher in 2mm × 2mm LQFN	Monolithic Synchronous Step-Down DC/DC Capable of Supplying 6A at Switching Frequencies up to 3MHz/10MHz. Silent Switcher Architecture for Ultralow EMI Emissions. 2.25V to 5.5V Input Operating Range. 0.5V to $V_{IN}$ Output Voltage Range with ±1% Accuracy. PGOOD Indication, RT Programming, SYNC Input. 2mm × 2mm LQFN.
<a href="#">LTC3315A/</a> <a href="#">LTC3315B</a>	Dual 5V, 2A Synchronous Step-Down DC/DCs in 2mm × 2mm LQFN	Dual Monolithic Synchronous Step-Down Voltage Regulators each Capable of Supplying 2A at Switching Frequencies up to 3MHz/10MHz. 2.25V to 5.5V Input Operating Range. 0.5V to $V_{IN}$ Output Voltage Range with ±1% Accuracy. PGOOD Indication, SYNC Input. 2mm × 2mm LQFN.
<a href="#">LTC3310/</a> <a href="#">LTC3310S</a> <a href="#">LTC3311/</a> <a href="#">LTC3311S</a>	5V, 10A/12.5A Synchronous Step-Down Silent Switcher/Silent Switcher 2 in 3mm × 3mm LQFN	Monolithic Synchronous Step-Down DC/DC Capable of Supplying 10A/12.5A at Switching Frequencies up to 5MHz. Silent Switcher Architecture for Ultralow EMI Emissions. 2.25V to 5.5V Input Operating Range. 0.5V to $V_{IN}$ Output Voltage Range with ±1% Accuracy. PGOOD Indication, RT Programming, SYNC Input. Configurable for Paralleling Power Stages. 3mm × 3mm LQFN.
<a href="#">LTC3370/</a> <a href="#">LTC3371</a>	4-Channel 8A Configurable 1A Buck DC/DCs	Four Synchronous Buck Regulators with 8 × 1A Power Stages. Can Connect Up to Four Power Stages in Parallel to Make a High Current Output (4A Maximum) with a Single Inductor, 8 Output Configurations Possible, Precision PGOOD Indication. LTC3371 Has a Watchdog Timer. LTC3370: 32-Lead 5mm × 5mm QFN. LTC3371: 38-Lead 5mm × 7mm QFN and TSSOP
<a href="#">LTC3374A</a>	8-Channel Parallelable 1A Buck DC/DCs	Eight 1A Synchronous Buck Regulators. Can Connect Up to Four Power Stages in Parallel to Make a High Current Output (4A Maximum) with a Single Inductor, 15 Output Configurations Possible. Precision Enable inputs and PGOOD_ALL reporting. 38-Lead 5mm × 7mm QFN and TSSOP
<a href="#">LTC3375</a>	8-Channel Parallelable 1A Buck DC/DCs	Eight 1A Synchronous Buck Regulators. Can Connect Up to Four Power Stages in Parallel to Make a High Current Output (4A Maximum) with a Single Inductor, 15 Output Configurations Possible. Precision Enable Inputs and PGOOD_ALL Reporting. I <sup>2</sup> C Programming with a Watchdog Timer and Pushbutton. 48-Lead 7mm × 7mm QFN
<a href="#">LTC3616</a>	5.5V, 6A, 4MHz, Synchronous Step-Down DC/DC Converter	95% Efficiency, $V_{IN}$ : 2.25 to 5.5V, $V_{OUT(MIN)}$ = 0.6V, $I_Q$ = 75μA, $I_{SD}$ < 1μA, 3mm × 5mm QFN-24 Package
<a href="#">LTC3412A</a>	3A, 4MHz, Monolithic Synchronous Step-Down Regulator	95% Efficiency, $V_{IN}$ : 2.25 to 5.5V, $V_{OUT(MIN)}$ = 0.8V, $I_Q$ = 64μA, $I_{SD}$ < 1μA, 4mm × 4mm QFN-16 Package

## X-ON Electronics

Largest Supplier of Electrical and Electronic Components

*Click to view similar products for [Power Management IC Development Tools](#) category:*

*Click to view products by [Analog Devices](#) manufacturer:*

Other Similar products are found below :

[EVB-EP5348UI](#) [BQ25010EVM](#) [ISL80019AEVAL1Z](#) [ISLUSBI2CKIT1Z](#) [ISL8002AEVAL1Z](#) [ISL91108IIA-EVZ](#) [ISL28022EVKIT1Z](#)  
[STEVAL-ISA008V1](#) [DRI0043](#) [KITPF8100FRDMEVM](#) [NCP10671B05GEVB](#) [EVB-EN6337QA](#) [SAMPLEBOXILD8150TOBO1](#)  
[AP62300WU-EVM](#) [KITA2GTC387MOTORCTRTOBO1](#) [AEK-MOT-TK200G1](#) [EVLONE65W](#) [STEVAL-ILH006V1](#) [STEVAL-IPE008V2](#)  
[STEVAL-IPP001V2](#) [STEVAL-ISA013V1](#) [STEVAL-ISA067V1](#) [STEVAL-ISQ002V1](#) [TPS2306EVM-001](#) [TPS2330EVM-185](#)  
[TPS40001EVM-001](#) [SECO-HVDCDC1362-15W-GEVB](#) [BTS7030-2EPA](#) [LTC3308AIV#WTRPBF](#) [TLT807B0EPV](#) [LT8641IUDC#WTRPBF](#)  
[BTS71033-6ESA](#) [EV13N91A](#) [EASYPIC V8 OVER USB-C](#) [EV55W64A](#) [RB-TO2S2](#) [RB-TSR1S2](#) [LV8813GGEVB](#) [RDP-02](#) [RDP-11](#) [73-553-0048](#) [AS-212](#) [MCP1630RD-NMC1](#) [MCP1631RD-MCC1](#) [ASM-02/24V](#) [ASM-03](#) [ASN-01/U](#) [ASO-205](#) [ASP-02](#) [MCP1631RD-DCPC1](#)