

## FEATURES

- **Manages Total Power Between a USB Peripheral and Battery Charger**
- **Minimal Voltage Drop (100mV at 500mA)**
- **Ultralow Battery Drain: 1 $\mu$ A**
- **Reverse Current Blocking Diode Not Required**
- Undervoltage Lockout
- Very Few External Components
- Compatible with Several LTC Linear Battery Chargers
- Overtemperature Protected
- Dual Battery Charge Priority Management
- Low Profile (1mm) SOT-23 Package

## APPLICATIONS

- Cellular Phones
- PDAs
- Digital Cameras
- MP3 Players
- Battery Backup Systems

## DESCRIPTION

The LTC<sup>®</sup>4410 enables simultaneous battery charging and operation of portable USB 1.0 and 2.0 compliant devices while they are connected to a USB port. As the USB peripheral load increases, the LTC4410 proportionally reduces the battery charge current to keep the total current less than 500mA or 100mA, depending on the state of the MODE pin.

The LTC4410 includes a USB present output that drives an external P-channel MOSFET to disconnect the battery from the USB peripheral when the USB power is valid. This allows device operation when connected to the USB port, even when the battery is deeply discharged.

Other features include reverse current blocking, thermal shutdown and low quiescent current (80 $\mu$ A in 500mA MODE) that is compliant with USB Suspend Mode.

The LTC4410 is available in the low profile (1mm) SOT-23 (ThinSOT<sup>™</sup>) package.

**LT**, LTC and LT are registered trademarks of Linear Technology Corporation.  
ThinSOT is a trademark of Linear Technology Corporation.

## TYPICAL APPLICATION

**USB Powered Battery Charger and Power Manager**

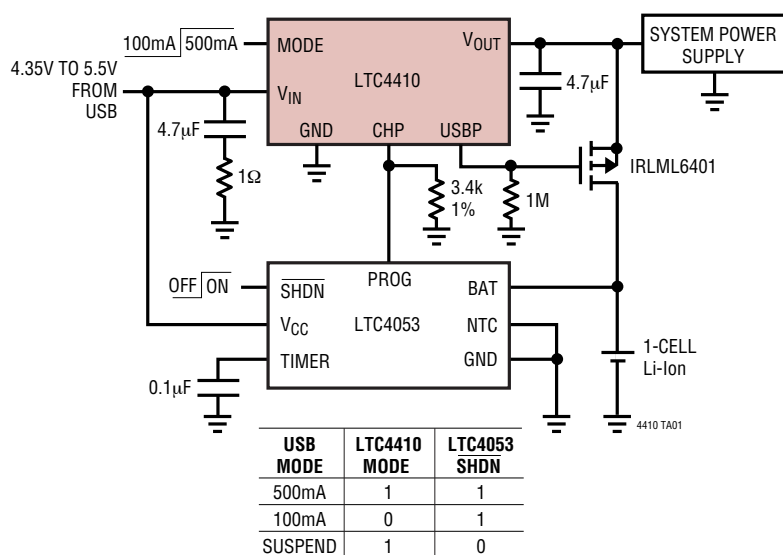

**System Load Step Response**

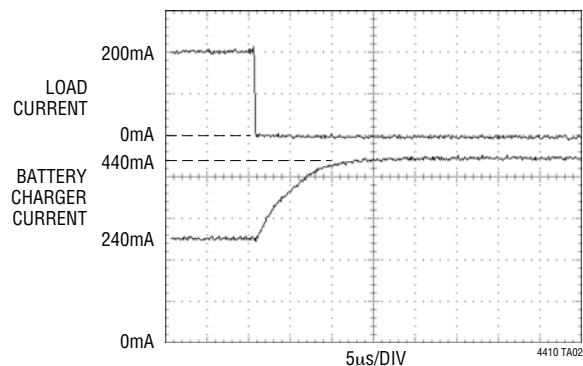

## ABSOLUTE MAXIMUM RATINGS

(Note 1)

$V_{IN}$ , $V_{OUT}$ Voltages .....	-0.3V to 6V
USBP, MODE, CHP Voltage .....	-0.3V to 6V
$I_{VOUT}$ (Note 5) .....	2A
Operating Ambient Temperature Range	
LTC4410E (Notes 3, 4) .....	-40°C to 85°C
Storage Temperature Range .....	-65°C to 150°C
Lead Temperature (Soldering, 10 sec) .....	300°C

## PACKAGE/ORDER INFORMATION

<p>S6 PACKAGE 6-LEAD PLASTIC TSOT-23 <math>T_{JMAX} = 125^{\circ}\text{C}</math>, <math>\theta_{JA} = 100^{\circ}\text{C/W}</math> TO <math>150^{\circ}\text{C/W}</math> DEPENDING ON PC BOARD LAYOUT</p>	ORDER PART NUMBER
	LTC4410ES6
	S6 PART MARKING
	LTK8

Consult LTC Marketing for parts specified with wider operating temperature ranges.

## ELECTRICAL CHARACTERISTICS

The ● denotes specifications that apply over the full operating temperature range, otherwise specifications are at  $T_A = 25^{\circ}\text{C}$ .  $V_{IN} = 5\text{V}$  unless otherwise noted.

PARAMETER	CONDITIONS	MIN	TYP	MAX	UNITS
Operating $V_{IN}$ Range		● 4.35		5.5	V
Quiescent Current—Active	100mA Mode (MODE = Low) 500mA Mode (MODE = High)		500 80	700 125	$\mu\text{A}$ $\mu\text{A}$
CHP Compliance Voltage	MODE = 5V, $I_{VOUT} = 500\text{mA}$ MODE = 0V, $I_{VOUT} = 0\text{mA}$	0 0		4.0 3.5	V V
Reverse Current	$V_{OUT} = 4\text{V}$ , $V_{IN} = 0\text{V}$		1	5	$\mu\text{A}$
MODE Input Current	MODE = 0V MODE = 5V		0.1 0.1	5 5	$\mu\text{A}$ $\mu\text{A}$
MODE Input High		● 1.2			V
MODE Input Low		●		0.4	V
USBP Output High	1M Resistor to GND, $V_{IN} = 5\text{V}$	4.8	4.98		V
USBP Output Low	1M Resistor to $V_{IN}$ , $V_{IN} = 3.5\text{V}$		20	100	mV
UVLO and USBP Threshold	Measured on $V_{IN}$ Rising	● 4.05	4.2	4.35	V
UVLO and USBP Hysteresis	Measured on $V_{IN}$	80	100	120	mV
CHP Output Current	MODE = High, $I_{VOUT} = 0\text{mA}$ (Note 2)		0	30	$\mu\text{A}$
	MODE = High, $I_{VOUT} = 500\text{mA}$ (Note 2)		470	530	$\mu\text{A}$
	MODE = High, $I_{VOUT} = 500\text{mA}$ , $T_A \geq 0^{\circ}\text{C}$ , (Note 2)	●	460	540	$\mu\text{A}$
	MODE = High, $I_{VOUT} = 500\text{mA}$ , $T_A < 0^{\circ}\text{C}$ , (Note 2)	●	450	550	$\mu\text{A}$
	MODE = Low, $I_{VOUT} = 0\text{mA}$ (Note 2)			370	$\mu\text{A}$
	MODE = Low, $I_{VOUT} = 100\text{mA}$ (Note 2)		430	510	$\mu\text{A}$

**Note 1:** Absolute Maximum Ratings are those values beyond which the life of a device may be impaired.

**Note 2:** Current flows out of CHP, voltage at CHP = 0V.

**Note 3:** The LTC4410E is guaranteed to meet performance specifications from 0°C to 70°C. Specifications over the -40°C to 85°C operating temperature range are assured by design, characterization and correlation with statistical process controls.

**Note 4:** This IC includes overtemperature protection that is intended to protect the device during momentary overload conditions. Junction temperature will exceed 125°C when overtemperature protection is active. Continuous operation above the specified maximum operating junction temperature may impair device reliability.

**Note 5:** Based on long-term current density limitations.

# TYPICAL PERFORMANCE CHARACTERISTICS

**I<sub>REF</sub> Turn-Off Response**

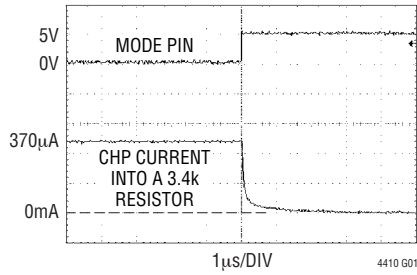

**CHP Current with I<sub>LOAD</sub> Step**

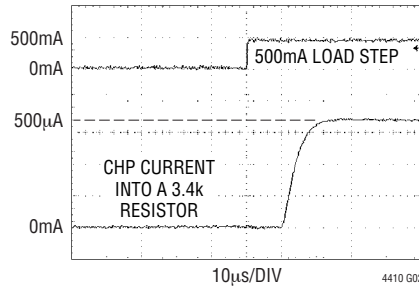

**I<sub>REF</sub> vs V<sub>IN</sub> (MODE = 0)**

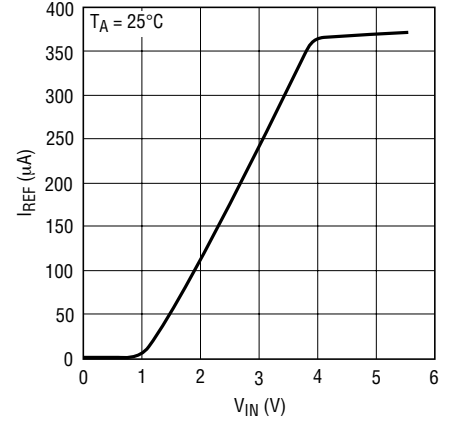

4410 G03

**I<sub>REF</sub> vs V<sub>CHP</sub> (MODE = 0)**

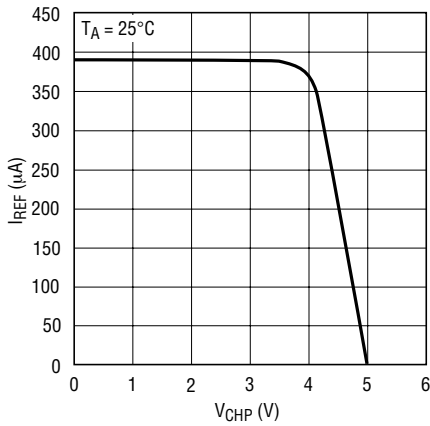

4410 G04

**R<sub>DS(ON)</sub> vs V<sub>IN</sub>**

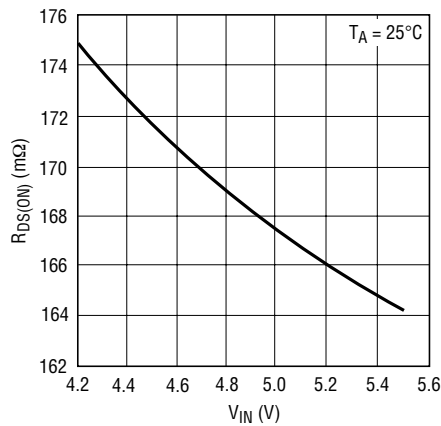

4410 G05

**R<sub>DS(ON)</sub> vs Temperature**

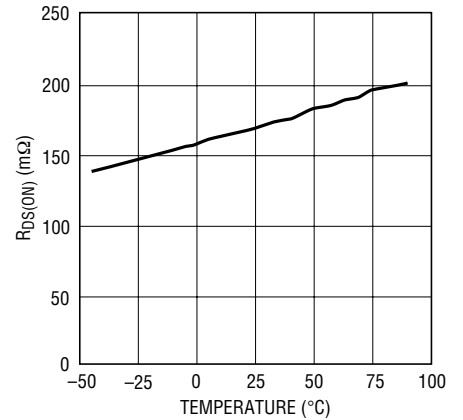

4410 G06

**Reverse Current vs Temperature**

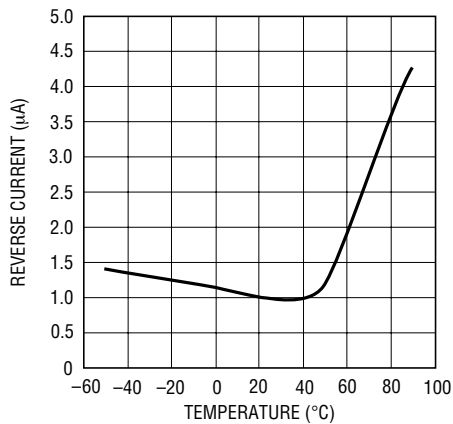

4410 G07

**I<sub>CC</sub> vs Temperature**

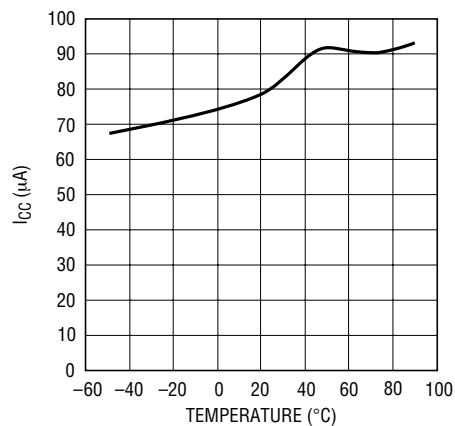

4410 G08

## PIN FUNCTIONS

**V<sub>IN</sub> (Pin 1):** Positive Input Supply. When  $V_{IN} > 4.2V$ , the internal undervoltage lockout enables the main switch that connects  $V_{IN}$  to  $V_{OUT}$ . Bypass  $V_{IN}$  with a  $10\mu F$  ceramic capacitor and a  $1\Omega$  resistor in series or use a  $10\mu F$  capacitor with at least  $1\Omega$  minimum ESR. This minimizes the voltage transient that can occur when the input is hot switched.

**GND (Pin 2):** Signal Ground for the LTC4410.

**MODE (Pin 3):** Mode Select Input. This pin selects the maximum USB port current of either 100mA or 500mA. When MODE is high, the current out of CHP will be  $I_{V_{OUT}}/1000$ . When MODE is low, the current out of CHP will be  $I_{V_{OUT}}/1000 + 370\mu A$  (typical).

**USBP (Pin 4):** USB Voltage Present Output. This pin goes high when  $V_{IN}$  exceeds the undervoltage lockout threshold ( $4.2V$  typical).

**CHP (Pin 5):** Charger Program Output. This pin sources a current that is used by the battery charger to control charge current.

**V<sub>OUT</sub> (Pin 6):** LTC4410 Output. Bypass this pin with a  $10\mu F$  or larger X5R ceramic capacitor. This capacitor may be omitted if other circuitry connected to  $V_{OUT}$  contains a bypass capacitor. When  $V_{OUT} > V_{IN}$ , the internal switch is held off, resulting in very low battery drain current ( $1\mu A$  typical).

## BLOCK DIAGRAM

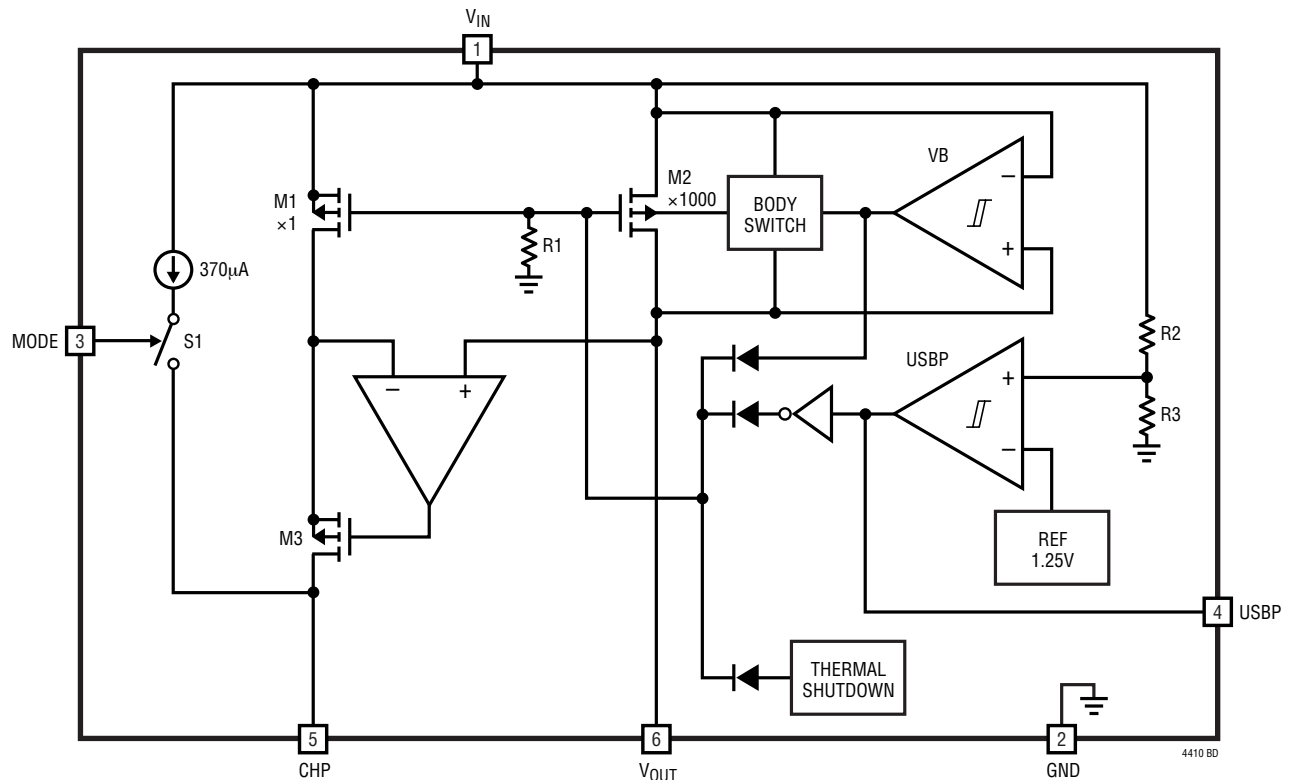

## OPERATION

The LTC4410 manages the total current consumption between a battery charger and a USB portable device. In a system using the LTC4410, a battery charger can be set up to charge at the maximum available current from the USB port without any need to reserve current for the device load. As the USB device current increases, the LTC4410 decreases the battery charge current so as not to exceed the maximum allowable current from the USB port. This allows for simultaneous battery charging and device operation. The LTC4410 can only reduce the battery charge current to zero. It is the responsibility of the USB device load to not exceed the USB power limits.

The LTC4410 uses an internal power MOSFET to sense load current. This MOSFET is held off when  $V_{OUT} > V_{IN}$  or  $V_{IN} < 4.2V$  (typ). A replica of the  $I_{VOUT}$  current equal to  $I_{VOUT}/1000$  is sourced out of the CHP pin with an accuracy of  $\pm 6\%$ . This current can be summed into the PROG node of a battery charger to reduce the charge current. The LTC4410 is primarily designed to interface with battery chargers that use a program pin to set the maximum charge current, with a charge current to program pin current ratio of 1000:1. The voltage on CHP can be externally monitored to signal overcurrent conditions.

When  $V_{IN} > 4.2V$ , the internal USB present comparator forces the USBP pin high. This signal can be used to detect

when the USB voltage is present and drive an external switch to connect or disconnect a battery from the USB peripheral.

The MODE pin controls the state of an internal  $370\mu A$  current reference ( $I_{REF}$ ). When active (MODE pin low), the total current sourced out of CHP is  $I_{VOUT}/1000 + I_{REF}$ . The primary function of the current reference is to offset the battery charger charge current for 100mA mode. When MODE is high, the current reference is disabled. The total current out of CHP with MODE high is  $I_{VOUT}/1000$ . The MODE controlled current offset makes it possible to configure the battery charger and the LTC4410 to support the USB specification 1.0 and 2.0 required 100mA and 500mA modes of operation.

The low quiescent current ( $80\mu A$ , when MODE is high) of the LTC4410 makes the system easily compliant with the USB specifications 1.0 and 2.0 SUSPEND MODE current consumption requirements.

When  $V_{OUT} > V_{IN}$ , the LTC4410 transitions to low power mode, draining  $1\mu A$  (typical) from the Lithium-Ion battery. This condition occurs when the USB device is operating off of its internal battery and not connected to the USB port.

## APPLICATIONS INFORMATION

### USB Power Management and Wall Adapter Power

With the addition of a few components, the LTC4410 allows for simultaneous device operation and battery charging while connected to USB port or wall adapter. The LTC4410 will proportionally reduce the battery charge current to keep the total current within the current rated for the wall adapter. Figure 1 shows an example of how to combine the USB power and wall adapter inputs. A P-channel MOSFET, MP1, is used to prevent back conducting into the USB port when a wall adapter is present. The pull-down resistor, R1, is to assure that MP1 is on

when there is no wall adapter. The Schottky diode, D1, is used to prevent USB power loss through R1. If the wall adapter used has more than 500mA capability, a resistor, R3, connected in parallel with R2 using N-channel MOSFET MN1 will increase the charge current when the wall adapter is present. In this example the battery charge current is 340mA without the wall adapter (see the LTC4053 data sheet for details on how to program the battery charge current). When the wall adapter is present, the charge current is 750mA.

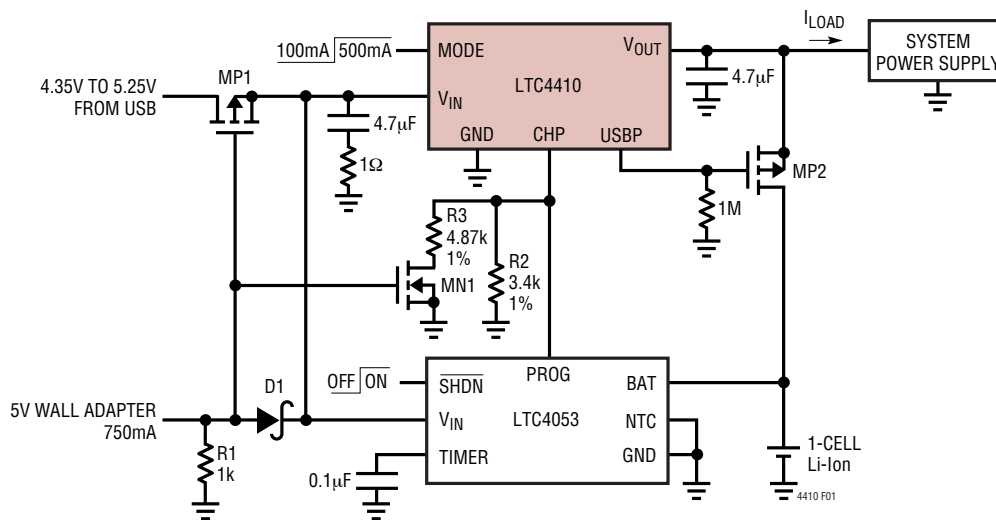

Figure 1. USB Power Management and Wall Adapter Power

## APPLICATIONS INFORMATION

### Dual Battery Charging with Priority

The LTC4410 can be used to manage two battery chargers, giving one of the chargers (see Figure 2) priority. When BAT1 is being charged, the charge current is flowing through the LTC4410. The LTC4410 is sensing the current and sourcing a current equal to BAT1 charge current/1000 out of CHP. This effectively reduces the BAT2 charger

current. As BAT1 current demands reduce, the current sourced out of CHP is reduced, enabling BAT2 to have more current. In this example the power supply is a 750mA minimum wall adapter,  $R_{\text{PROG}}$  (R2 and R3) for the chargers are 2k $\Omega$ , resulting in a 750mA charge current. In this application, the total current out of the wall adapter will never exceed 750mA.

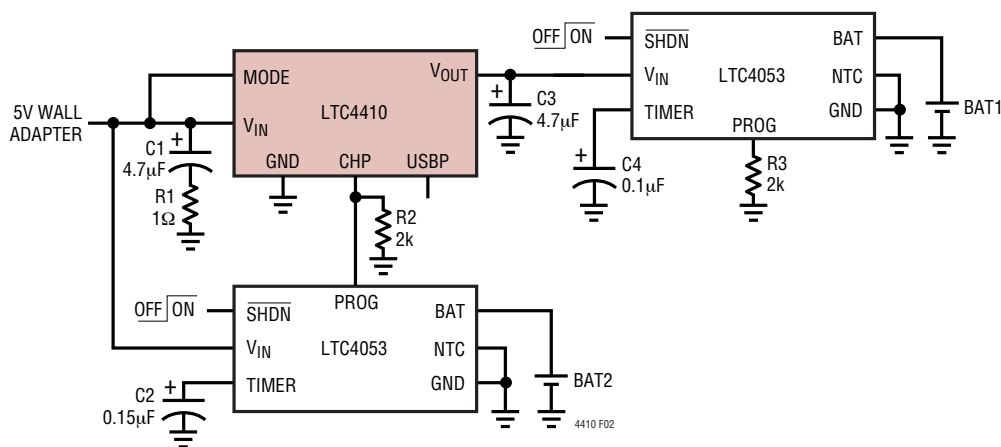
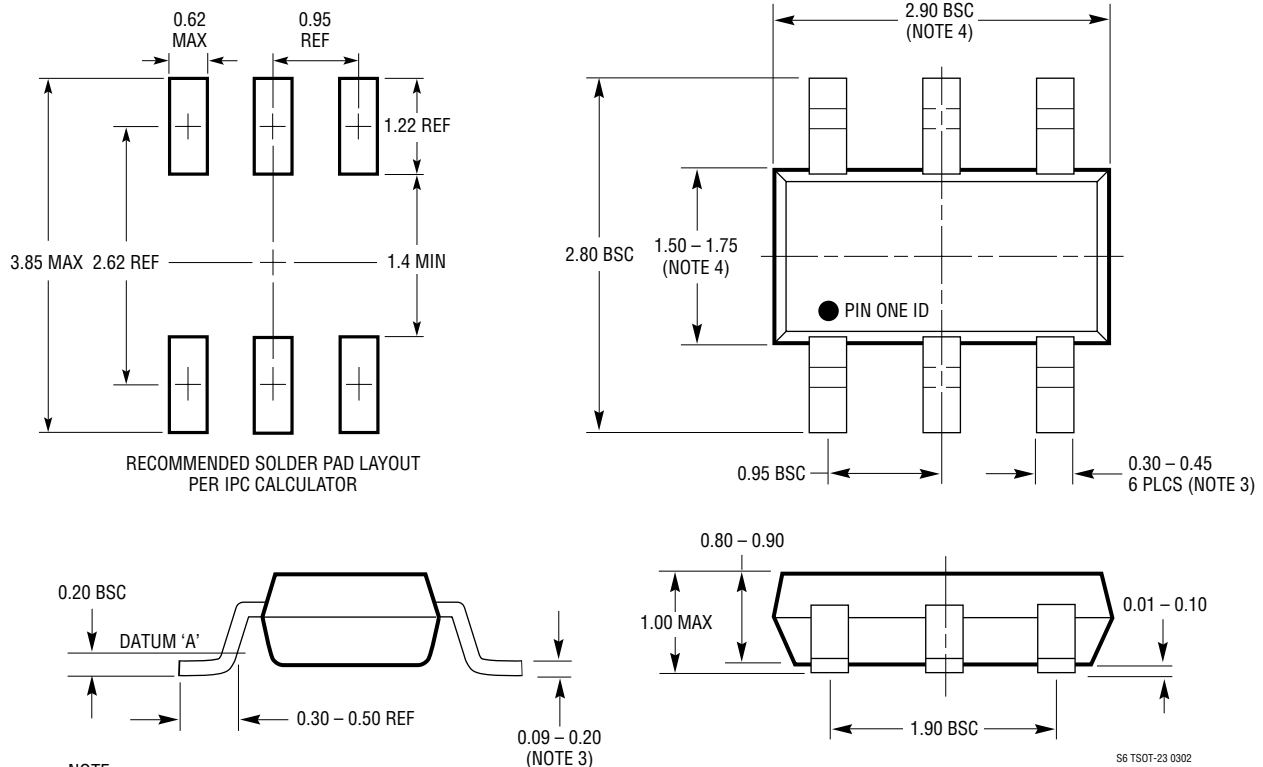

Figure 2. Priority Dual Battery Charging with Wall Adapter

## PACKAGE DESCRIPTION

**S6 Package**  
**6-Lead Plastic TSOT-23**  
 (Reference LTC DWG # 05-08-1636)



- NOTE:
1. DIMENSIONS ARE IN MILLIMETERS
  2. DRAWING NOT TO SCALE
  3. DIMENSIONS ARE INCLUSIVE OF PLATING
  4. DIMENSIONS ARE EXCLUSIVE OF MOLD FLASH AND METAL BURR
  5. MOLD FLASH SHALL NOT EXCEED 0.254mm
  6. JEDEC PACKAGE REFERENCE IS MO-193

## RELATED PARTS

PART NUMBER	DESCRIPTION	COMMENTS
LTC1733	Li-Ion Linear Charger with Thermal Regulation	Standalone Charger, No External MOSFET, Diode or Sense Resistor
LTC1734	200mA to 700mA Li-Ion Charger in ThinSOT	Tiny Design, No Blocking Diode, No Sense Resistor
LTC1734L	50mA to 180mA Li-Ion Charger in ThinSOT	Tiny Design, High Accuracy for Low Charge Current, No Blocking Diode, No Sense Resistor
LTC4053	USB Li-Ion Battery Charger	Operates from USB Port, 100mA/500mA Charge Capability, Standalone Charger
LTC4054	800mA Li-Ion Battery Charger in ThinSOT	Standalone Charger, Thermal Regulation, C/10 Charge Termination
LTC4055	USB Power Controller and Li-Ion Linear Charger	Load Dependent Charging Guarantees USB Input Current Compliance, Automatic Battery Switchover when Supply is Removed, Tiny 4mm x 4mm QFN Package
LTC4412	PowerPath™ Controller in ThinSOT	More Efficient than Diode OR'ing, Automatic Switching Between DC Sources, Simplified Load Sharing, $3V \leq V_{IN} \leq 28V$

PowerPath is a trademark of Linear Technology Corporation.



## X-ON Electronics

Largest Supplier of Electrical and Electronic Components

*Click to view similar products for [USB Interface IC](#) category:*

*Click to view products by [Analog Devices](#) manufacturer:*

Other Similar products are found below :

[CY7C69356-48LTXC](#) [USB3319C-GJ-TR](#) [USB3370B-EZK-TR](#) [CYPD2120-24LQXI](#) [CYPD2122-20FNXIT](#) [CYPD2122-24LQXIT](#) [LIF-UC120-SWG36ITR50](#) [UPD360-A/6HX](#) [CP2102NP1174GM](#) [CG8454AM](#) [DPO2039DABQ-13](#) [PTN3816EWY](#) [CY7C68034-56LTXC](#) [TUSB213IRGYT](#) [TUSB213RGYT](#) [USB3503T-I/ML](#) [CY7C63310-SXC](#) [USB3316C-CP-TR](#) [USB3250-ABZJ](#) [FT220XS-R](#) [MAX3107ETG+](#) [NCP360SNT1G](#) [MAX14632EZK+T](#) [USB3300-EZK](#) [STUSB03EQR](#) [LAN9514-JZX](#) [USB5807/KD](#) [CYPD2120-24LQXIT](#) [USB5826-I/KD](#) [USB5826/KD](#) [USB5906/KD](#) [USB5916/KD](#) [USB5926/KD](#) [VNC2-32L1C-TRAY](#) [TUSB215QRGYTQ1](#) [TUSB522PRGER](#) [NB7NPQ701MMTTBG](#) [TUSB213RGYR](#) [TUSB214RWBR](#) [USB5926-I/KD](#) [USB5906-I/KD](#) [USB4640I-HZH-03](#) [CY7C63813-SXC](#) [CY7C63823-SXC](#) [CY7C64215-28PVXC](#) [CY7C68013A-128AXC](#) [CY7C68013A-56LTXI](#) [CY7C68013A-56PVXC](#) [CY7C68013A-56PVXI](#) [CYPD1120-40LQXI](#)