

## MAX25302A/MAX25302B

## 2A Automotive Low-Noise LDO Linear Regulators

### General Description

The MAX25302A/MAX25302B are 1.7V to 5.5V  $V_{IN}$ , low-noise linear regulators that delivers up to 2A of output current with only  $5.1\mu V_{RMS}$  of output noise from 10Hz to 100kHz. The regulator maintains  $\pm 1\%$  output accuracy over a wide input voltage range, requiring only 100mV of input-to-output headroom at full load. The 1.3mA no-load supply current is independent of dropout voltage.

The output voltage on the MAX25302B can be adjusted to a value in the range of 0.6V to 5.0V by using two external resistors. The MAX25302B also includes an active-high POK signal for trouble-free load startup.

The MAX25302A has nine pin-selectable output voltages: 1.2V, 1.5V, 1.8V, 2.5V, 3.0V, 3.1V, 3.3V, 4.0V, and 5V.

All versions include a programmable output soft-start rate, output overcurrent, and thermal-overload protection.

The MAX25302A/MAX25302B are offered in a 3mm x 3.5mm, 14-pin TDFN package.

### Applications

- Automotive Electronics
- High-End Audio Systems
- High-Resolution Data-Acquisition Systems

### Benefits and Features

- Delivers Flexible Operating Range
  - 1.7V to 5.5V Input Voltage Range
  - 0.6V to 5.0V Programmable Output Voltage
  - 2A Maximum Output Current
  - 100mV Maximum Dropout at 2A Load
  - $< 1.5\mu A$  Shutdown Supply Current
- Reduces Noise and Improves Accuracy
  - $\pm 1\%$  DC Accuracy over Load, Line, and Temperature
  - $5.1\mu V_{RMS}$  Output Noise, 10Hz to 100kHz
  - 1.3mA Quiescent Supply Current
  - $> 70\text{dB}$  PSRR at 10kHz
- Enables Ease-of-Use and Robust Protection
  - Stable with  $8\mu F$  (min) Output Capacitance
  - Programmable Soft-Start Rate
  - Overcurrent and Overtemperature Protection
  - Output-to-Input Reverse-Current Protection
  - Power-OK Status Pin
- Reduces PC Board Area
  - 3mm x 3.5mm, 14-pin TDFN Package
- AEC-Q100
  - $-40^{\circ}\text{C}$  to  $+125^{\circ}\text{C}$  Operating Temperature

Typical Operating Circuits

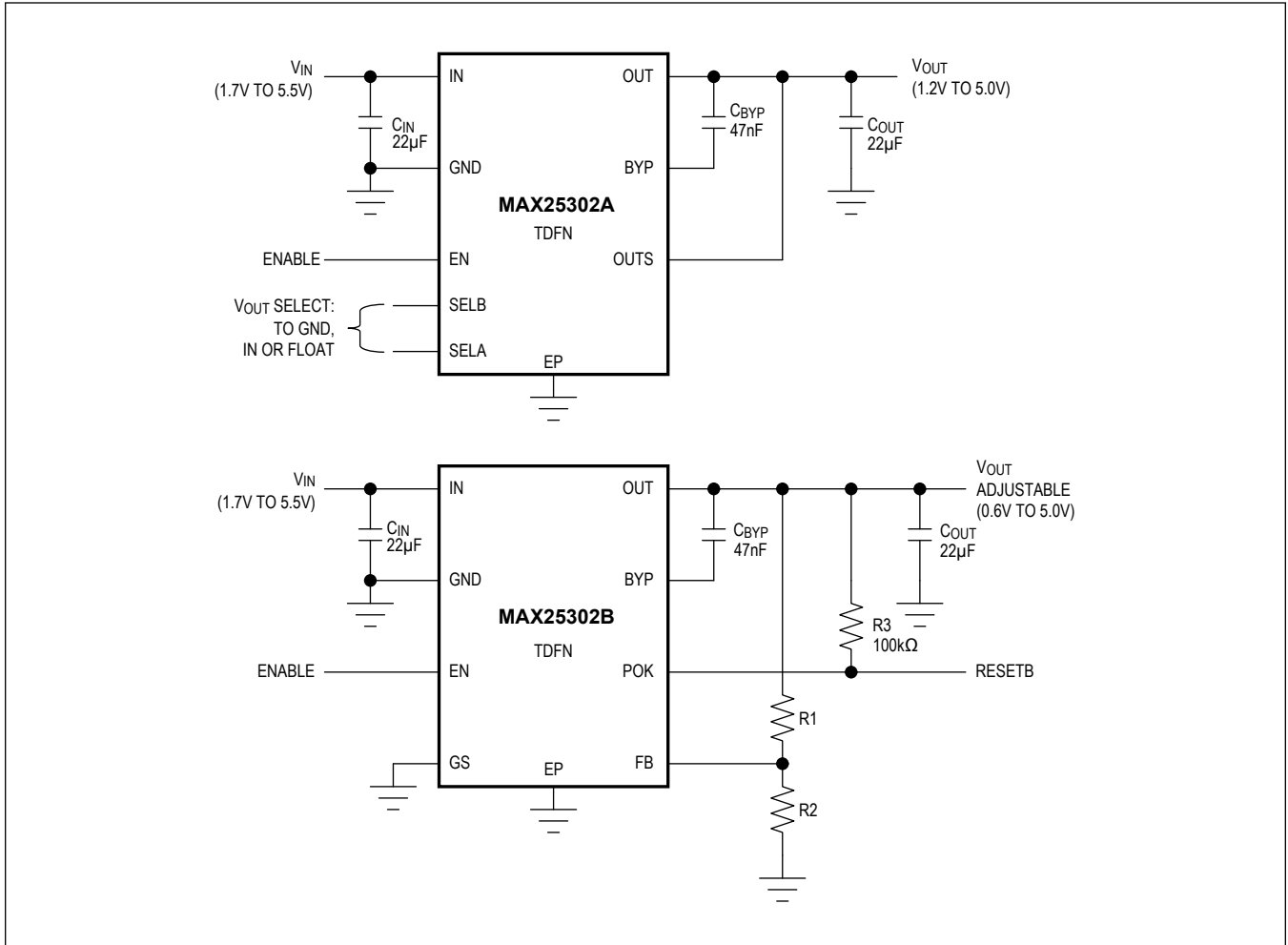

## Absolute Maximum Ratings

IN, OUT, SELA, SELB, EN to GND .....	-0.3V to +6V	Operating Temperature Range .....	-40°C to +125°C
POK, OUTS, FB, GS to GND .....	-0.3V to +6V	Maximum Junction Temperature .....	+150°C
BYP .....	-0.3V to +2V	Storage Temperature Range .....	-65°C to +150°C
Output Short-Circuit Duration .....	Continuous	Soldering Temperature (reflow) .....	+260°C
Continuous Power Dissipation TDFN (T <sub>A</sub> = +70°C, derate 24.4mW/°C above +70°C.) .....	1951mW		

Stresses beyond those listed under "Absolute Maximum Ratings" may cause permanent damage to the device. These are stress ratings only, and functional operation of the device at these or any other conditions beyond those indicated in the operational sections of the specifications is not implied. Exposure to absolute maximum rating conditions for extended periods may affect device reliability.

## Package Information

### TDFN

Package Code	T143A3+1C
Outline Number	<a href="#">21-100420</a>
Land Pattern Number	<a href="#">90-100149</a>
<b>Thermal Resistance, Single-Layer Board:</b>	
Junction to Ambient (θ <sub>JA</sub> )	54°C/W
Junction to Case (θ <sub>JC</sub> )	8°C/W
<b>Thermal Resistance, Four-Layer Board:</b>	
Junction to Ambient (θ <sub>JA</sub> )	41°C/W
Junction to Case (θ <sub>JC</sub> )	8°C/W

## Electrical Characteristics

(V<sub>IN</sub> = 3.6V, T<sub>J</sub> = -40°C to +125°C, C<sub>BYP</sub> = 47nF, C<sub>IN</sub> = 22μF, C<sub>OUT</sub> = 22μF, Typical Operating Circuit, unless otherwise specified. (Note 1))

PARAMETER	SYMBOL	CONDITIONS	MIN	TYP	MAX	UNITS
Input Voltage Range	V <sub>IN</sub>	Guaranteed by output accuracy	1.7		5.5	V
Input Undervoltage Lockout	V <sub>UVLO</sub>	V <sub>IN</sub> rising, 100mV hysteresis	1.5	1.6	1.7	V
Output Voltage Range	V <sub>OUT</sub>	V <sub>IN</sub> > V <sub>OUT</sub> + 0.1V	0.6		5.0	V
Output Capacitance	C <sub>OUT</sub>	For stability and proper operation	8	22		μF
Supply Current	I <sub>IN</sub>	V <sub>EN</sub> = V <sub>IN</sub> = 3.6V, I <sub>OUT</sub> = 0mA		1300		μA
		V <sub>EN</sub> = 0V	T <sub>A</sub> = +25°C	0.04	1.5	
			T <sub>A</sub> = 125°C	1.5		
FB Regulation Accuracy (MAX25302B Only)	ACC	I <sub>OUT</sub> from 0.1mA to 2A, V <sub>IN</sub> from V <sub>OUT</sub> + 0.3V to 5.5V, V <sub>IN</sub> > 1.7V	0.594	0.6	0.606	V
OUT Regulation Accuracy (MAX25302A Only)	ACC	I <sub>OUT</sub> from 0.1mA to 2A, V <sub>IN</sub> from V <sub>OUT</sub> + 0.3V to 5.5V, V <sub>IN</sub> > 1.7V	-1		+1	%
Load Regulation		V <sub>IN</sub> = 2.8V, V <sub>OUT</sub> = 2.5V, I <sub>OUT</sub> from 0.1mA to 2A		0.032		%
Load Transient		Output voltage deviation with a load change of I <sub>OUT</sub> = 50mA to 2.0A to 50mA, with t <sub>RISE</sub> = t <sub>FALL</sub> = 1μs		50		mV <sub>P-P</sub>

### Electrical Characteristics (continued)

( $V_{IN} = 3.6V$ ,  $T_J = -40^{\circ}C$  to  $+125^{\circ}C$ ,  $C_{BYP} = 47nF$ ,  $C_{IN} = 22\mu F$ ,  $C_{OUT} = 22\mu F$ , Typical Operating Circuit, unless otherwise specified. (Note 1))

PARAMETER	SYMBOL	CONDITIONS		MIN	TYP	MAX	UNITS
Line Regulation		$V_{IN}$ from 2.8V to 5.5V, $V_{OUT} = 2.5V$ , $I_{OUT} = 800mA$			0.054		%/V
Line Transient		$V_{IN} = 4V$ to $5V$ to $4V$ , $I_{OUT} = 2A$ , $t_{RISE} = t_{FALL} = 5\mu s$			3		mV <sub>P-P</sub>
Dropout Voltage (Note 2)		$I_{OUT} = 2A$	$V_{IN} = 3.6V$	47	100	mV	
			$V_{IN} = 2.5V$ (Note 3)	65	200		
			$V_{IN} = 1.7V$	100	300		
Current Limit		$V_{OUT} = 95\%$ of regulation, $V_{IN} - V_{OUT} = 0.5V$ , $V_{IN} = 3.6V$		2.2	2.8	3.4	A
Output Noise		$I_{OUT} = 100mA$ , $C_{BYP} = 100nF$	$f = 10Hz$ to $100kHz$		5.1		$\mu V_{RMS}$
Power Supply Rejection Ratio	PSRR	$V_{IN} = V_{OUT} + 400mV$ , $I_{OUT} = 1.6A$	$f = 1kHz$		70	dB	
			$f = 10kHz$		70		
			$f = 100kHz$		60		
			$f = 1MHz$		40		
BYP Capacitor Range	$C_{BYP}$	Regulator remain stable		0.001		0.1	$\mu F$
BYP Soft-Start Current		From BYP to GND during startup			50		$\mu A$
EN Input Threshold		$V_{IN}$ from 1.7V to 5.5V	EN rising		0.8	1.2	V
EN Input Threshold		$V_{IN}$ from 1.7V to 5.5V	EN falling	0.4	0.7		V
EN Input Leakage Current		$V_{EN}$ from 1.7V to 5.5V	$T_A = +25^{\circ}C$	-1	+0.001	+1	$\mu A$
		$V_{EN}$ from 1.7V to 5.5V	$T_A = +125^{\circ}C$		0.01		
POK Threshold (MAX25302B Only)		$V_{OUT}$ when POK switches	$V_{OUT}$ rising	88	91	94	%
			$V_{OUT}$ falling		88		
POK Voltage, Low (MAX25302B Only)	$V_{OL}$	$I_{POK} = 1mA$			10	100	mV
POK Leakage Current (MAX25302B Only)		$V_{POK} = 5.5V$	$T_A = +25^{\circ}C$	-0.1	+0.001	+0.1	$\mu A$
			$T_A = +125^{\circ}C$		0.01		
SELA/B Input Resistance (MAX25302A Only)	$R_{INSELA/B}$	When shorted to GND or IN				500	$\Omega$
		When Hi-Z		1			
SELA/B Input Capacitance (MAX25302A Only)	$C_{INSELA/B}$	When Hi-Z				10	pF
IN Reverse-Current Threshold	$I_{IN\_REV}$	$V_{OUT} = 3.6V$ , when $V_{IN}$ falls to 0V			800		mA
Thermal Shutdown Threshold		$T_J$ when output turns on/off	$T_J$ rising		165		$^{\circ}C$
			$T_J$ falling		150		

**Note 1:** Limits over the specified operating temperature and supply voltage range are guaranteed by design and characterization, and production tested at room temperature only.

**Note 2:** Dropout voltage is defined as  $(V_{IN} - V_{OUT})$  when  $V_{OUT}$  is 95% of its nominal value.

**Note 3:** Guaranteed by design and characterization.

### Typical Operating Characteristics

(MAX25302BATD+,  $V_{IN} = 3.6V$ ,  $V_{OUT} = 2.5V$ ,  $C_{BYP} = 47nF$ ,  $C_{IN} = 22\mu F$ ,  $C_{OUT} = 22\mu F$ ,  $T_A = +25^\circ C$ , unless otherwise noted.)

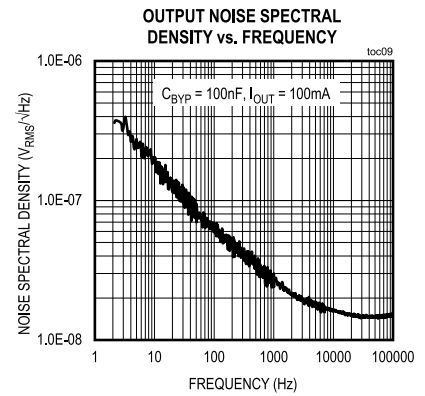
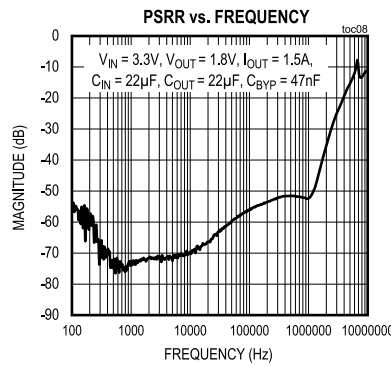
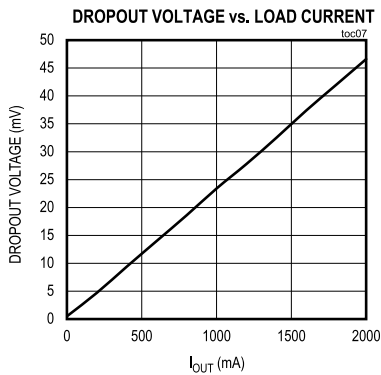
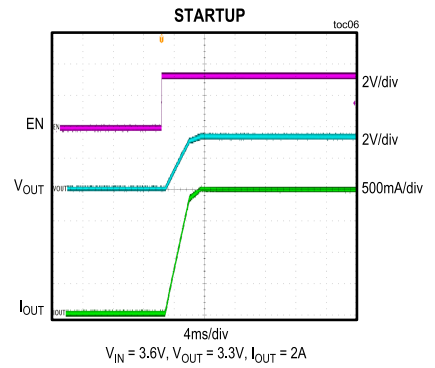
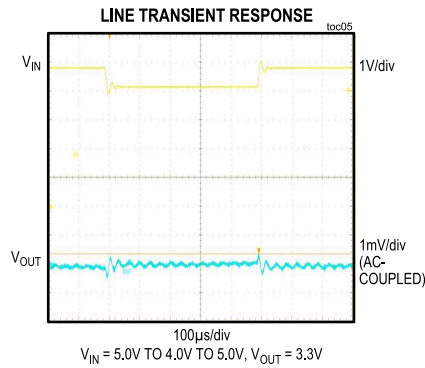
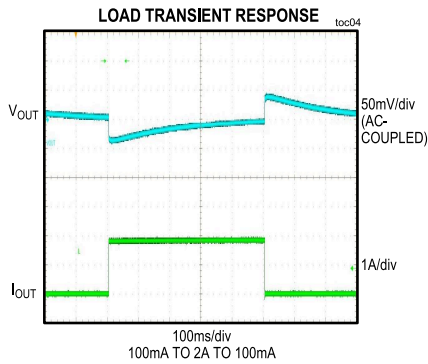
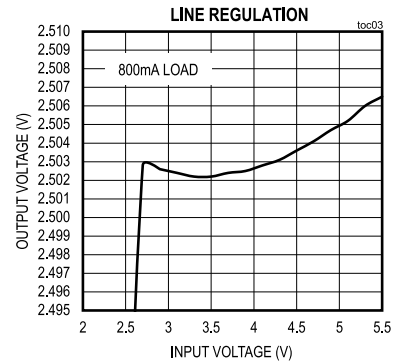
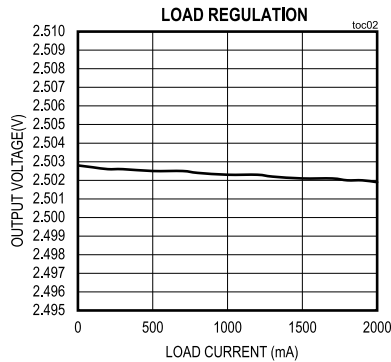
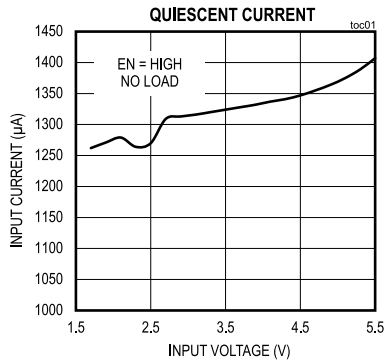

### Pin Configurations

#### MAX25302A

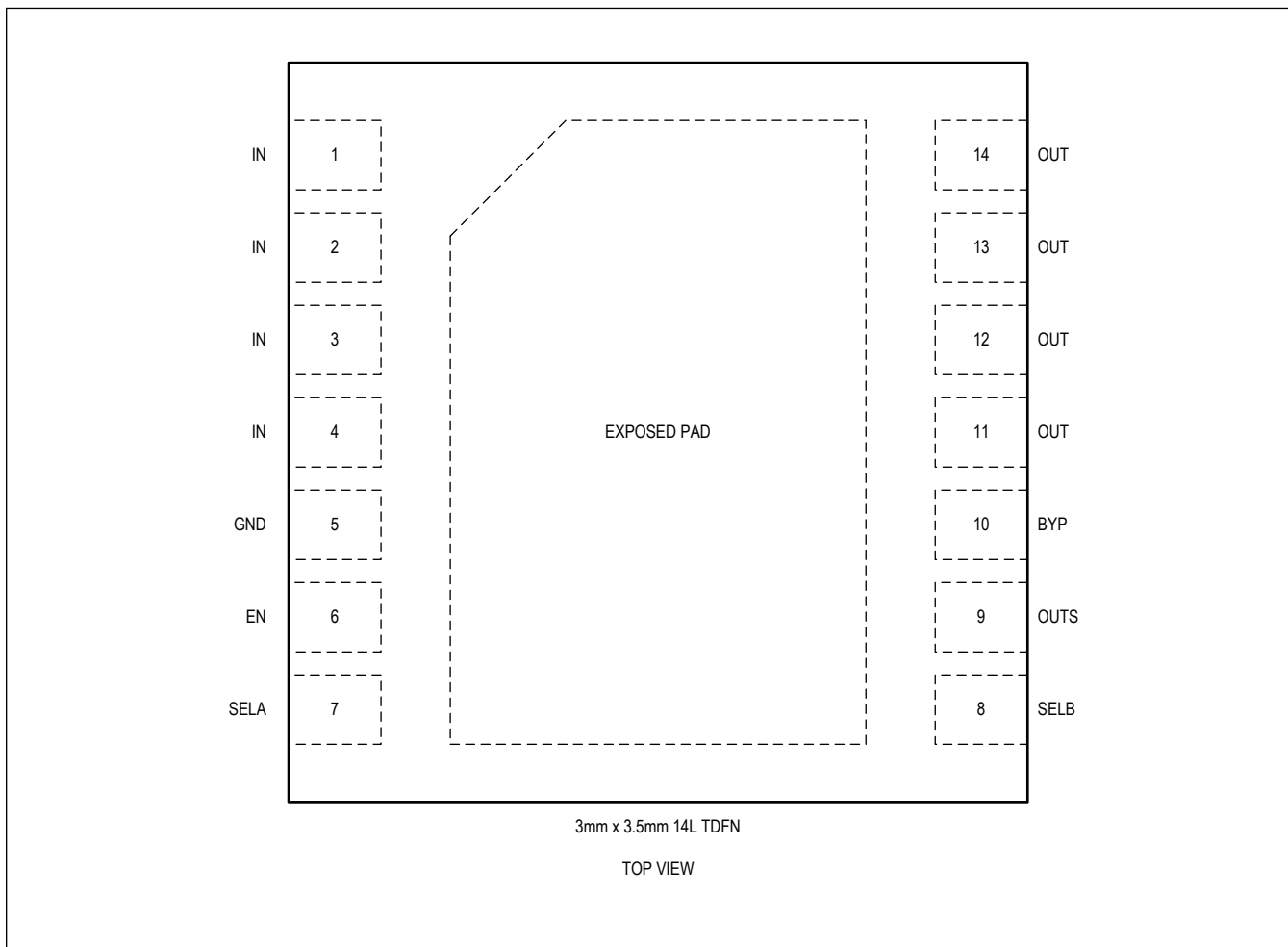

**MAX25302B**

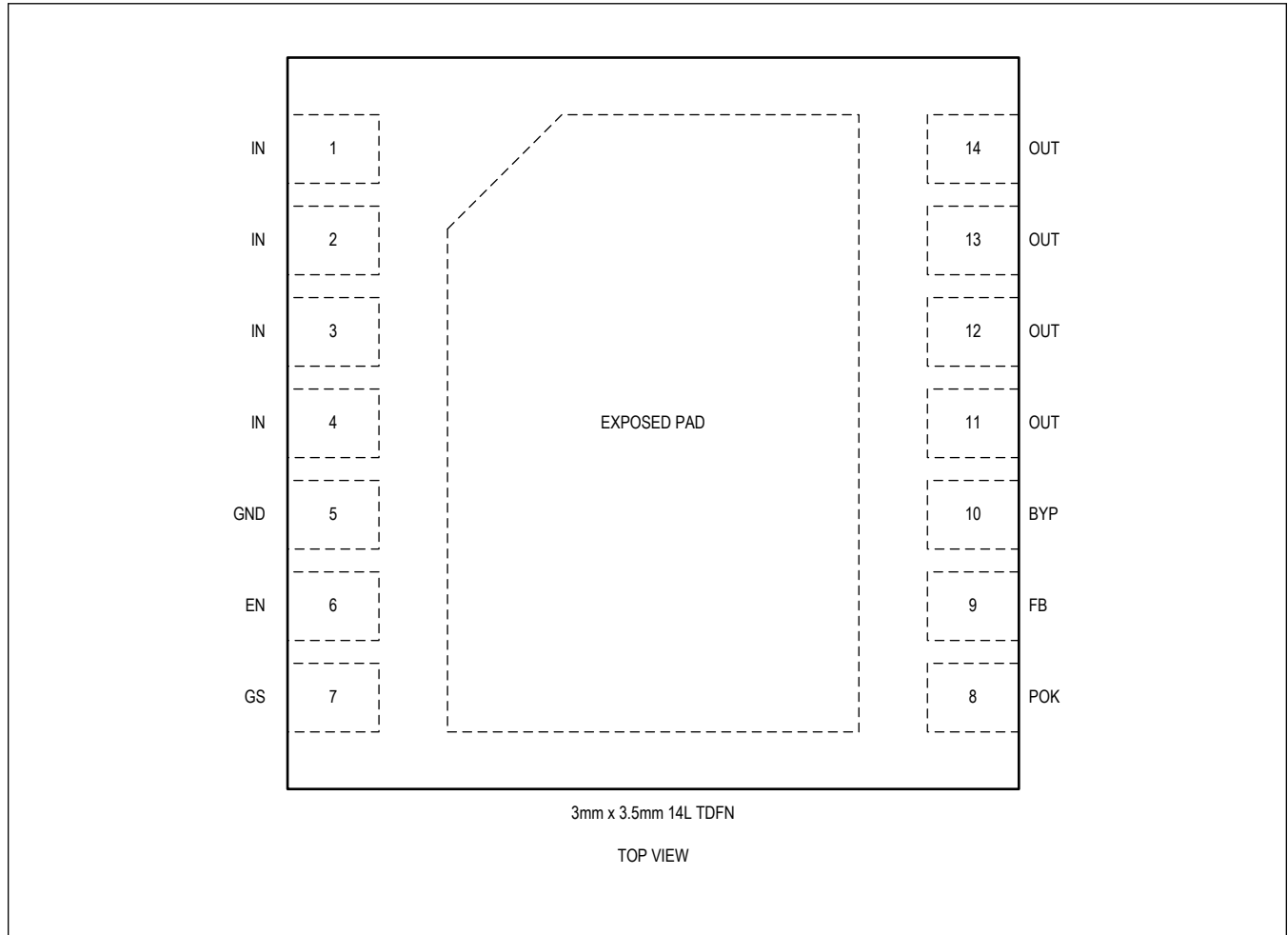

**Pin Description**

PIN		NAME	FUNCTION
MAX25302A	MAX25302B		
1, 2, 3, 4	1, 2, 3, 4	IN	Regulator Supply Input. Connect to a voltage between 1.7V and 5.5V and bypass with a 22µF capacitor from IN to GND.
5	5	GND	Regulator Ground. Connect IN and OUT bypass capacitor GND connections to this pin for best performance.
6	6	EN	Enable Input. Connect this pin to a logic signal to enable ( $V_{EN}$ high) or disable ( $V_{EN}$ low) the regulator output. Connect to IN to keep the output enable whenever a valid supply voltage is present.
7	—	SELA	Output Select Input. Connect to GND, IN, or Hi-Z to select one of three states. The states of the SELA and SELB pins are read when the device is enabled, and are used to select one of nine output voltages.
—	7	GS	Ground Sense. Connect GS to GND.



## Pin Description (continued)

PIN		NAME	FUNCTION
MAX25302A	MAX25302B		
8	—	SELB	Output Select Input. Connect to GND, IN, or Hi-Z to select one of three states. The states of the SELA and SELB pins are read when the device is enabled, and are used to select one of nine output voltages.
—	8	POK	Active-High Power-OK Output. Connect a pull-up resistor from this pin to a supply to create a reset signal that goes high after the regulator output has reached its regulation voltage.
9	—	OUTS	Output Voltage Sense Input. Connect to the load at a point where accurate regulation is required to eliminate resistive metal drops.
—	9	FB	Feedback Divider Input. Connect a resistor-divider string from OUT to GND with the midpoint tied to this pin to set the output voltage. In the <a href="#">Typical Application Circuits</a> , $V_{OUT} = 0.6V \times (1 + R1/R2)$ .
10	10	BYP	Bypass Capacitor Input. Connect a capacitor with a value from 0.001 $\mu$ F to 0.1 $\mu$ F between OUT and BYP to reduce output noise and set the regulator soft-start rate.
11, 12, 13, 14	11, 12, 13, 14	OUT	Regulator Output. Sources up to 2A at the output regulation voltage. Bypass with a 22 $\mu$ F (8 $\mu$ F minimum, including voltage derating) low-ESR (< 0.03 $\Omega$ ) capacitor to GND.
EP	EP	EP	Exposed Pad (TDFN Only). Connect the exposed pad to a ground plane with low thermal resistance to ambient to provide best heat sinking.

Simplified Functional Diagram

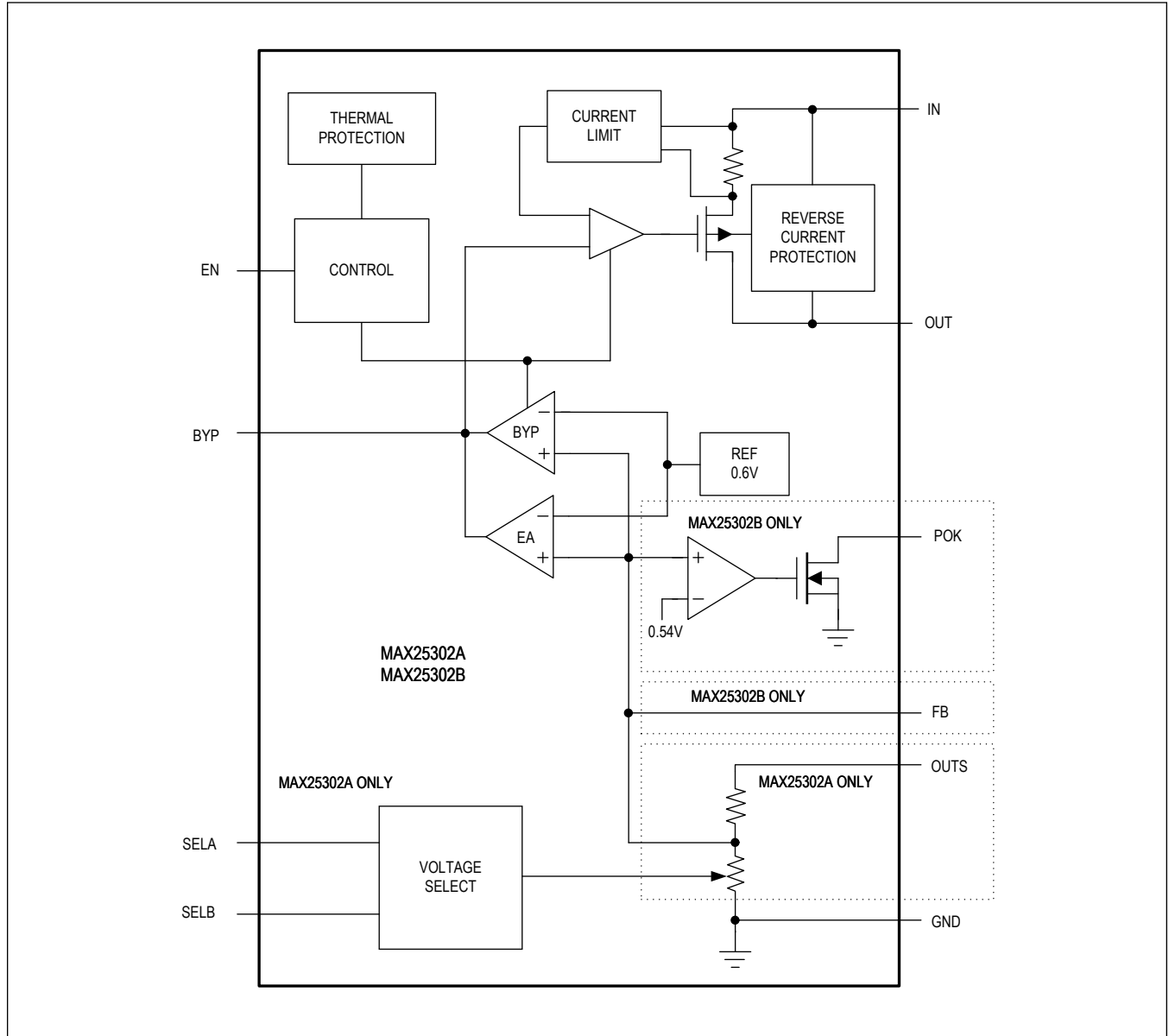

## Detailed Description

The MAX25302A/MAX25302B are high-performance pMOS linear regulators that are optimized for low noise, high-input-supply rejection, low dropout voltage, and small solution size. They can deliver up to a maximum load current of 2A while maintaining a low dropout voltage of 47mV. An enable input allows the regulator to be powered up and down, while an internal soft-start circuit controls the inrush current at the input. SELA and SELB inputs are provided on the A version for selecting one of nine output voltages and a power-OK output is provided on the B version for system power-up sequencing.

### Enable (EN)

The MAX25302A/MAX25302B include an enable pin (EN). Pull EN low to shut down the output, or drive EN high to enable the output. If a separate shutdown signal is not available, connect EN to IN.

### Bypass (BYP)

The capacitor connected from BYP to OUT filters noise at the reference, feedback resistors, and regulator input stage. It provides a high-speed feedback path for improved transient response. A 10nF capacitor rolls off noise at around 32Hz.

The slew rate of the output voltage during startup is also determined by the BYP capacitor. A 10nF capacitor sets the slew rate to 5V/ms. This startup rate results in a 110mA slew current drawn from the input at startup to charge 22μF output capacitance.

The BYP capacitor value can be adjusted from 1nF to 100nF to change the startup slew rate according to the following formula:

$$\text{StartupSlewRate} = \frac{5\text{V}}{\text{ms}} \times \frac{10\text{nF}}{C_{\text{BYP}}}$$

where  $C_{\text{BYP}}$  is in nF.

Note that this slew rate applies only at startup. Recovery from a short circuit will occur at a slew rate approximately 500 times slower.

Also, note that being a low-frequency filter node, BYP is sensitive to leakage. BYP leakage currents above 10nA cause measurable inaccuracy at the output and should be avoided.

### Protection Features

The MAX25302A/MAX25302B are fully protected from an output short circuit by a current-limiting and thermal-overload circuit. If the output is shorted to GND, the output current is limited to 2.8A (typ). Under these conditions, the device quickly heats up. When the junction temperature reaches +165°C, a thermal-limit circuit shuts the output device off. Once the device cools to +150°C, the output turns back on in an attempt to reestablish regulation. If the fault persists, the output current cycles on and off as the junction temperature slews between +150°C and +165°C.

The MAX25302A/MAX25302B are also protected against reverse current when the output voltage is higher than the input. In the event that extra output capacitance is used at the output, a power down transient at the input would normally cause a large reverse current through a conventional regulator. The MAX25302A/MAX25302B include a reverse-voltage detector that trips when IN drops 10mV below OUT, shutting off the regulator and opening the pMOS body diode connection and preventing any reverse current.

### Output Voltage Configuration (MAX25302A)

The MAX25302A has two configuration pins, SELA and SELB, that are read during power-up to determine the output regulation voltage.

**Table 1. MAX25302A Output Configuration Table**

V <sub>OUT</sub> (V)	SELA	SELB
1.2	Hi-Z	IN
1.5	IN	Hi-Z

**Table 1. MAX25302A Output Configuration Table (continued)**

1.8	Hi-Z	GND
2.5	Hi-Z	Hi-Z
3.0	GND	GND
3.1	GND	IN
3.3	GND	Hi-Z
4.0	IN	GND
5.0	IN	IN

**Output Voltage Configuration (MAX25302B)**

The MAX25302B uses external feedback resistors to set the output regulation voltage as shown in the [Typical Operating Circuits](#). The output voltage can be set from 0.6V to 5.0V. Set the lower feedback resistor R2 to 300kΩ or less to minimize FB input bias current error. Then, calculate the value of the upper feedback resistor R1 as follows:

$$R1 = R2 \times \left( \frac{V_{OUT}}{V_{FB}} - 1 \right)$$

where  $V_{FB}$  is the feedback regulation voltage of 0.6V.

To set the output to 2.4V, for example, R1 should be:

$$R1 = 300k\Omega \times \left( \frac{2.4V}{0.6V} - 1 \right) = 900k\Omega$$

**Power-OK (MAX25302B)**

The MAX25302B includes an additional open-drain output, POK, that goes high to indicate that the output voltage is in regulation. Connect a pull-up resistor from this pin to an external supply. During startup, POK stays low until the output voltage rises to 91% (typ) of its regulation level. If an overload event occurs at the output, or the output is shutdown, POK goes low.

**Input Capacitor**

A 22μF ceramic capacitor is recommended for the input. Select a capacitor that does not degrade significantly over temperature and DC bias. Capacitors with X5R or X7R temperature characteristics generally perform well.

**Output Capacitor**

A minimum of 8μF capacitance is required at OUT to ensure stable operation. Select a ceramic capacitor that maintains its capacitance (8μF minimum) over temperature and DC bias. Capacitors with X5R or X7R temperature characteristics generally perform well.

**Thermal Considerations**

The MAX25302A/MAX25302B are packaged in a 14-pin, 3mm x 3.5mm TDFN package with an exposed paddle. The exposed paddle is the main thermal path for heat to escape the IC, and therefore, must be connected to a ground plane with thermal vias to allow heat to dissipate from the device. Thermal properties of the package are given in the [Package Information](#) section.

Typical Application Circuits

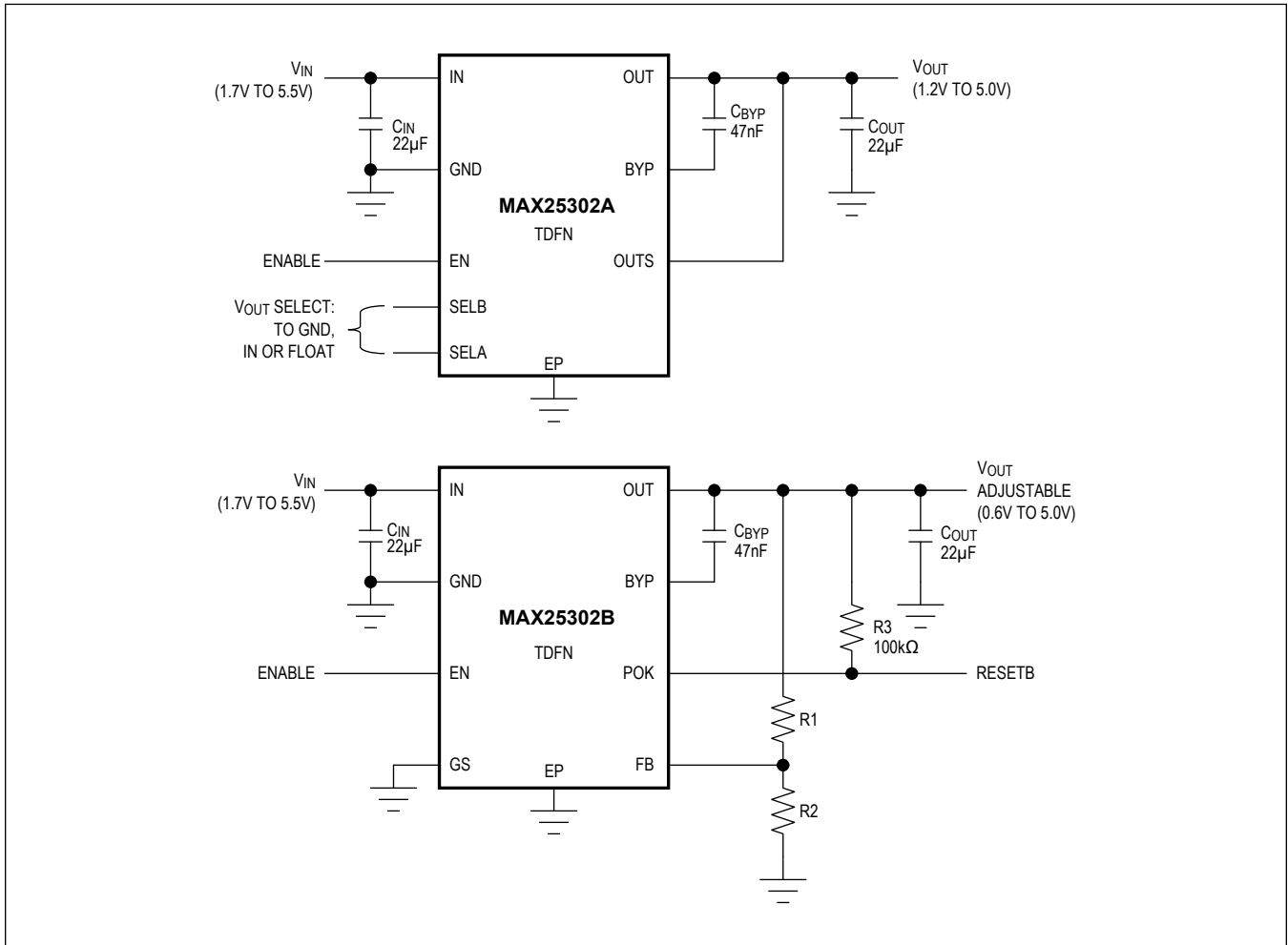

Ordering Information

PART NUMBER	TEMP RANGE	PIN-PACKAGE	FEATURES
MAX25302AATD/ V+	-40°C to +125°C	14-pin, 3mm x 3.5mm, TDFN	Pin-Selectable Output Voltage, Enable
MAX25302BATD/ V+	-40°C to +125°C	14-pin, 3mm x 3.5mm, TDFN	External Resistor Feedback, POK Output with Delay, Enable

*/V* Denotes an automotive qualified part

*+* Denotes a lead(Pb)-free/RoHS-compliant package.

Devices are also available in tape-and-reel packaging. Specify tape and reel by adding "T" to the part number when ordering.

## Revision History

REVISION NUMBER	REVISION DATE	DESCRIPTION	PAGES CHANGED
0	8/20	Initial release	—
1	1/23	Updated Pin Configuration, Pin Description table, Detailed Description, and Ordering Information table	7, 8, 9, 12, 13

## X-ON Electronics

Largest Supplier of Electrical and Electronic Components

*Click to view similar products for [Linear Voltage Regulators](#) category:*

*Click to view products by [Analog Devices](#) manufacturer:*

Other Similar products are found below :

[LV5684PVD-XH](#) [MCDTSA6-2R](#) [L7815ACV-DG](#) [714954EB](#) [ZMR500QFTA](#) [BA033LBSG2-TR](#) [LV5680P-E](#) [L79M05T-E](#) [L78LR05D-MA-E](#) [NCV317MBTG](#) [NTE7227](#) [MP2018GZD-33-P](#) [MP2018GZD-5-P](#) [LV5680NPVC-XH](#) [LT1054CN8](#) [ZTS6538SE](#) [UA78L09CLP](#) [UA78L09CLPR](#) [CAT6221-PPTD-GT3](#) [MC78M09CDTRK](#) [NCV51190MNTAG](#) [78M05](#) [HT7150-1](#) [UM1540DB-18](#) [XC6234H281VR-G](#) [WL2834CA-6/TR](#) [TPL730F33-5TR](#) [TLS850F1TA](#) [V50](#) [TPS549B22RVFR](#) [UM1540DB-33](#) [WL9200P3-50B](#) [WL9100P3-33B](#) [WL9005D4-33](#) [XC6219B152MR](#) [WL2855K33-3/TR](#) [PJ54BM33SE](#) [PJ9500M25SA](#) [MD7218E33PC1](#) [H7533-2PR](#) [SK7812AU](#) [SD1A30](#) [78L33](#) [TP78L33T3](#) [L78L33ACUTR](#) [SK6513ST3A-50](#) [SK6054D4-09](#) [SK6054D4-18](#) [SK6054D4-11](#) [SK6054D4-10](#) [LM79L12F](#)