

MAX481/MAX483/MAX485/ MAX487–MAX491/MAX1487

低功耗、限摆率、 RS-485/RS-422收发器

概述

MAX481、MAX483、MAX485、MAX487–MAX491以及MAX1487是用于RS-485与RS-422通信的低功耗收发器，每个器件中都具有一个驱动器和一个接收器。MAX483、MAX487、MAX488以及MAX489具有限摆率驱动器，可以减小EMI，并降低由不恰当的终端匹配电缆引起的反射，实现最高250kbps的无差错数据传输。MAX481、MAX485、MAX490、MAX491、MAX1487的驱动器摆率不受限制，可以实现最高2.5Mbps的传输速率。

这些收发器在驱动器禁用的空载或满载状态下，吸取的电源电流在120 μ A至500 μ A之间。另外，MAX481、MAX483与MAX487具有低电流关断模式，仅消耗0.1 μ A电流。所有器件都工作在5V单电源下。

驱动器具有短路电流限制，并可以通过热关断电路将驱动器输出置为高阻状态，防止过度的功率损耗。接收器输入具有失效保护特性，当输入开路时，可以确保逻辑高电平输出。

MAX487与MAX1487具有四分之一单位负载的接收器输入阻抗，使得总线上最多可以有128个MAX487/MAX1487收发器。使用MAX488–MAX491可以实现全双工通信，而MAX481、MAX483、MAX485、MAX487与MAX1487则为半双工应用设计。

应用

低功耗RS-485收发器

低功耗RS-422收发器

电平转换器

用于EMI敏感应用的收发器

工业控制局域网

下一代器件的特性

◆ 容错应用

MAX3430: \pm 80V故障保护、失效保护、1/4单位负载、+3.3V、RS-485收发器

MAX3440E–MAX3444E: \pm 15kV ESD保护、 \pm 60V故障保护、10Mbps、失效保护、

RS-485/J1708收发器

◆ 对于空间受限应用

MAX3460–MAX3464: +5V、失效保护、20Mbps、Profibus RS-485/RS-422收发器

MAX3362: +3.3V、高速、RS-485/RS-422收发器，采用SOT23封装

MAX3280E–MAX3284E: \pm 15kV ESD保护、52Mbps、+3V至+5.5V、SOT23、RS-485/RS-422、真失效保护接收器

MAX3293/MAX3294/MAX3295: 20Mbps、+3.3V、SOT23、RS-485/RS-422发送器

◆ 对于多通道收发器应用

MAX3030E–MAX3033E: \pm 15kV ESD保护、+3.3V、四路RS-422发送器

◆ 对于失效保护应用

MAX3080–MAX3089: 失效保护、高速(10Mbps)、限摆率RS-485/RS-422收发器

◆ 对于低电压应用

MAX3483E/MAX3485E/MAX3486E/MAX3488E/MAX3490E/MAX3491E: +3.3V供电、 \pm 15kV ESD保护、12Mbps、限摆率、真正的RS-485/RS-422收发器

订购信息在数据资料的最后给出。

选型表

PART NUMBER	HALF/FULL DUPLEX	DATA RATE (Mbps)	SLEW-RATE LIMITED	LOW-POWER SHUTDOWN	RECEIVER/DRIVER ENABLE	QUIESCENT CURRENT (μ A)	NUMBER OF RECEIVERS ON BUS	PIN COUNT
MAX481	Half	2.5	No	Yes	Yes	300	32	8
MAX483	Half	0.25	Yes	Yes	Yes	120	32	8
MAX485	Half	2.5	No	No	Yes	300	32	8
MAX487	Half	0.25	Yes	Yes	Yes	120	128	8
MAX488	Full	0.25	Yes	No	No	120	32	8
MAX489	Full	0.25	Yes	No	Yes	120	32	14
MAX490	Full	2.5	No	No	No	300	32	8
MAX491	Full	2.5	No	No	Yes	300	32	14
MAX1487	Half	2.5	No	No	Yes	230	128	8

本文是英文数据资料的译文，文中可能存在翻译上的不准确或错误。如需进一步确认，请在您的设计中参考英文资料。

有关价格、供货及订购信息，请联络Maxim亚洲销售中心：10800 852 1249 (北中国区)，10800 152 1249 (南中国区)，或访问Maxim的中文网站：china.maximintegrated.com。

MAX481/MAX483/MAX485/MAX487–MAX491/MAX1487

低功耗、限摆率、 RS-485/RS-422收发器

ABSOLUTE MAXIMUM RATINGS

Supply Voltage (V _{CC}).....	12V	14-Pin SO (derate 8.33mW/°C above +70°C).....	667mW
Control Input Voltage (\overline{RE} , DE).....	-0.5V to (V _{CC} + 0.5V)	8-Pin μ MAX (derate 4.1mW/°C above +70°C).....	830mW
Driver Input Voltage (DI).....	-0.5V to (V _{CC} + 0.5V)	8-Pin CERDIP (derate 8.00mW/°C above +70°C).....	640mW
Driver Output Voltage (A, B).....	-8V to +12.5V	14-Pin CERDIP (derate 9.09mW/°C above +70°C).....	727mW
Receiver Input Voltage (A, B).....	-8V to +12.5V	Operating Temperature Ranges	
Receiver Output Voltage (RO).....	-0.5V to (V _{CC} + 0.5V)	MAX4_ _C_ _/MAX1487C_ A	0°C to +70°C
Continuous Power Dissipation (T _A = +70°C)		MAX4_ _E_ _/MAX1487E_ A	-40°C to +85°C
8-Pin Plastic DIP (derate 9.09mW/°C above +70°C)	727mW	MAX4_ _MJ_/MAX1487MJA	-55°C to +125°C
14-Pin Plastic DIP (derate 10.00mW/°C above +70°C) ..	800mW	Storage Temperature Range	
8-Pin SO (derate 5.88mW/°C above +70°C).....	471mW	-65°C to +160°C	
		Lead Temperature (soldering, 10sec)	
		+300°C	

Stresses beyond those listed under "Absolute Maximum Ratings" may cause permanent damage to the device. These are stress ratings only, and functional operation of the device at these or any other conditions beyond those indicated in the operational sections of the specifications is not implied. Exposure to absolute maximum rating conditions for extended periods may affect device reliability.

DC ELECTRICAL CHARACTERISTICS

(V_{CC} = 5V \pm 5%, T_A = T_{MIN} to T_{MAX}, unless otherwise noted.) (Notes 1, 2)

PARAMETER	SYMBOL	CONDITIONS		MIN	TYP	MAX	UNITS
Differential Driver Output (no load)	V _{OD1}			5			V
Differential Driver Output (with load)	V _{OD2}	R = 50 Ω (RS-422)		2			V
		R = 27 Ω (RS-485), Figure 4		1.5			
Change in Magnitude of Driver Differential Output Voltage for Complementary Output States	Δ V _{OD}	R = 27 Ω or 50 Ω , Figure 4		0.2			V
Driver Common-Mode Output Voltage	V _{OC}	R = 27 Ω or 50 Ω , Figure 4		3			V
Change in Magnitude of Driver Common-Mode Output Voltage for Complementary Output States	Δ V _{OD}	R = 27 Ω or 50 Ω , Figure 4		0.2			V
Input High Voltage	V _{IH}	DE, DI, \overline{RE}		2.0			V
Input Low Voltage	V _{IL}	DE, DI, \overline{RE}		0.8			V
Input Current	I _{IN1}	DE, DI, \overline{RE}		\pm 2			μ A
Input Current (A, B)	I _{IN2}	DE = 0V; V _{CC} = 0V or 5.25V, all devices except MAX487/MAX1487	V _{IN} = 12V	1.0		mA	
			V _{IN} = -7V	-0.8			
	MAX487/MAX1487, DE = 0V, V _{CC} = 0V or 5.25V	V _{IN} = 12V	0.25		mA		
		V _{IN} = -7V	-0.2				
Receiver Differential Threshold Voltage	V _{TH}	-7V \leq V _{CM} \leq 12V		-0.2	0.2		V
Receiver Input Hysteresis	Δ V _{TH}	V _{CM} = 0V		70			mV
Receiver Output High Voltage	V _{OH}	I _O = -4mA, V _{ID} = 200mV		3.5			V
Receiver Output Low Voltage	V _{OL}	I _O = 4mA, V _{ID} = -200mV		0.4			V
Three-State (high impedance) Output Current at Receiver	I _{OZR}	0.4V \leq V _O \leq 2.4V		\pm 1			μ A
Receiver Input Resistance	R _{IN}	-7V \leq V _{CM} \leq 12V, all devices except MAX487/MAX1487		12			k Ω
		-7V \leq V _{CM} \leq 12V, MAX487/MAX1487		48			k Ω

MAX481/MAX483/MAX485/MAX487–MAX491/MAX1487

低功耗、限摆率、 RS-485/RS-422收发器

DC ELECTRICAL CHARACTERISTICS (continued)

($V_{CC} = 5V \pm 5\%$, $T_A = T_{MIN}$ to T_{MAX} , unless otherwise noted.) (Notes 1, 2)

PARAMETER	SYMBOL	CONDITIONS	MIN	TYP	MAX	UNITS
No-Load Supply Current (Note 3)	I _{CC}	MAX488/MAX489, DE, DI, $\overline{RE} = 0V$ or V_{CC}		120	250	μA
		MAX490/MAX491, DE, DI, $\overline{RE} = 0V$ or V_{CC}		300	500	
		MAX481/MAX485, $\overline{RE} = 0V$ or V_{CC}	DE = V_{CC}	500	900	
			DE = 0V	300	500	
		MAX1487, $\overline{RE} = 0V$ or V_{CC}	DE = V_{CC}	300	500	
			DE = 0V	230	400	
		MAX483/MAX487, $\overline{RE} = 0V$ or V_{CC}	DE = 5V	MAX483	350	
MAX487	250			400		
	DE = 0V	120	250			
Supply Current in Shutdown	I _{SHDN}	MAX481/483/487, DE = 0V, $\overline{RE} = V_{CC}$		0.1	10	μA
Driver Short-Circuit Current, $V_O = \text{High}$	I _{OSD1}	-7V ≤ V_O ≤ 12V (Note 4)	35		250	mA
Driver Short-Circuit Current, $V_O = \text{Low}$	I _{OSD2}	-7V ≤ V_O ≤ 12V (Note 4)	35		250	mA
Receiver Short-Circuit Current	I _{OSR}	0V ≤ V_O ≤ V_{CC}	7		95	mA

SWITCHING CHARACTERISTICS—MAX481/MAX485, MAX490/MAX491, MAX1487

($V_{CC} = 5V \pm 5\%$, $T_A = T_{MIN}$ to T_{MAX} , unless otherwise noted.) (Notes 1, 2)

PARAMETER	SYMBOL	CONDITIONS	MIN	TYP	MAX	UNITS
Driver Input to Output	t _{PLH}	Figures 6 and 8, R _{DIFF} = 54Ω, C _{L1} = C _{L2} = 100pF	10	30	60	ns
	t _{PHL}		10	30	60	
Driver Output Skew to Output	t _{SKEW}	Figures 6 and 8, R _{DIFF} = 54Ω, C _{L1} = C _{L2} = 100pF		5	10	ns
Driver Rise or Fall Time	t _R , t _F	MAX481, MAX485, MAX1487	3	15	40	ns
		MAX490C/E, MAX491C/E	5	15	25	
		MAX490M, MAX491M	3	15	40	
Driver Enable to Output High	t _{ZH}	Figures 7 and 9, C _L = 100pF, S2 closed		40	70	ns
Driver Enable to Output Low	t _{ZL}	Figures 7 and 9, C _L = 100pF, S1 closed		40	70	ns
Driver Disable Time from Low	t _{LZ}	Figures 7 and 9, C _L = 15pF, S1 closed		40	70	ns
Driver Disable Time from High	t _{HZ}	Figures 7 and 9, C _L = 15pF, S2 closed		40	70	ns
Receiver Input to Output	t _{PLH} , t _{PHL}	MAX481, MAX485, MAX1487	20	90	200	ns
		MAX490C/E, MAX491C/E	20	90	150	
		MAX490M, MAX491M	20	90	200	
t _{PLH} - t _{PHL} Differential Receiver Skew	t _{SKD}	Figures 6 and 10, R _{DIFF} = 54Ω, C _{L1} = C _{L2} = 100pF		13		ns
Receiver Enable to Output Low	t _{ZL}	Figures 5 and 11, C _R L = 15pF, S1 closed		20	50	ns
Receiver Enable to Output High	t _{ZH}	Figures 5 and 11, C _R L = 15pF, S2 closed		20	50	ns
Receiver Disable Time from Low	t _{LZ}	Figures 5 and 11, C _R L = 15pF, S1 closed		20	50	ns
Receiver Disable Time from High	t _{HZ}	Figures 5 and 11, C _R L = 15pF, S2 closed		20	50	ns
Maximum Data Rate	f _{MAX}		2.5			Mbps
Time to Shutdown	t _{SHDN}	MAX481 (Note 5)	50	200	600	ns

MAX481/MAX483/MAX485/MAX487–MAX491/MAX1487

低功耗、限摆率、RS-485/RS-422收发器

SWITCHING CHARACTERISTICS—MAX481/MAX485, MAX490/MAX491, MAX1487 (continued)

(V_{CC} = 5V ±5%, T_A = T_{MIN} to T_{MAX}, unless otherwise noted.) (Notes 1, 2)

PARAMETER	SYMBOL	CONDITIONS	MIN	TYP	MAX	UNITS
Driver Enable from Shutdown to Output High (MAX481)	t _{ZH(SHDN)}	Figures 7 and 9, C _L = 100pF, S2 closed		40	100	ns
Driver Enable from Shutdown to Output Low (MAX481)	t _{ZL(SHDN)}	Figures 7 and 9, C _L = 100pF, S1 closed		40	100	ns
Receiver Enable from Shutdown to Output High (MAX481)	t _{ZH(SHDN)}	Figures 5 and 11, C _L = 15pF, S2 closed, A - B = 2V		300	1000	ns
Receiver Enable from Shutdown to Output Low (MAX481)	t _{ZL(SHDN)}	Figures 5 and 11, C _L = 15pF, S1 closed, B - A = 2V		300	1000	ns

SWITCHING CHARACTERISTICS—MAX483, MAX487/MAX488/MAX489

(V_{CC} = 5V ±5%, T_A = T_{MIN} to T_{MAX}, unless otherwise noted.) (Notes 1, 2)

PARAMETER	SYMBOL	CONDITIONS	MIN	TYP	MAX	UNITS
Driver Input to Output	t _{PLH}	Figures 6 and 8, R _{DIFF} = 54Ω, C _{L1} = C _{L2} = 100pF	250	800	2000	ns
	t _{PHL}		250	800	2000	
Driver Output Skew to Output	t _{SKEW}	Figures 6 and 8, R _{DIFF} = 54Ω, C _{L1} = C _{L2} = 100pF		100	800	ns
Driver Rise or Fall Time	t _R , t _F	Figures 6 and 8, R _{DIFF} = 54Ω, C _{L1} = C _{L2} = 100pF	250		2000	ns
Driver Enable to Output High	t _{ZH}	Figures 7 and 9, C _L = 100pF, S2 closed	250		2000	ns
Driver Enable to Output Low	t _{ZL}	Figures 7 and 9, C _L = 100pF, S1 closed	250		2000	ns
Driver Disable Time from Low	t _{LZ}	Figures 7 and 9, C _L = 15pF, S1 closed	300		3000	ns
Driver Disable Time from High	t _{HZ}	Figures 7 and 9, C _L = 15pF, S2 closed	300		3000	ns
Receiver Input to Output	t _{PLH}	Figures 6 and 10, R _{DIFF} = 54Ω, C _{L1} = C _{L2} = 100pF	250		2000	ns
	t _{PHL}		250		2000	
t _{PLH} - t _{PHL} Differential Receiver Skew	t _{SKD}	Figures 6 and 10, R _{DIFF} = 54Ω, C _{L1} = C _{L2} = 100pF		100		ns
Receiver Enable to Output Low	t _{ZL}	Figures 5 and 11, C _R _L = 15pF, S1 closed		20	50	ns
Receiver Enable to Output High	t _{ZH}	Figures 5 and 11, C _R _L = 15pF, S2 closed		20	50	ns
Receiver Disable Time from Low	t _{LZ}	Figures 5 and 11, C _R _L = 15pF, S1 closed		20	50	ns
Receiver Disable Time from High	t _{HZ}	Figures 5 and 11, C _R _L = 15pF, S2 closed		20	50	ns
Maximum Data Rate	f _{MAX}	t _{PLH} , t _{PHL} < 50% of data period	250			kbps
Time to Shutdown	t _{SHDN}	MAX483/MAX487 (Note 5)	50	200	600	ns
Driver Enable from Shutdown to Output High	t _{ZH(SHDN)}	MAX483/MAX487, Figures 7 and 9, C _L = 100pF, S2 closed			2000	ns
Driver Enable from Shutdown to Output Low	t _{ZL(SHDN)}	MAX483/MAX487, Figures 7 and 9, C _L = 100pF, S1 closed			2000	ns
Receiver Enable from Shutdown to Output High	t _{ZH(SHDN)}	MAX483/MAX487, Figures 5 and 11, C _L = 15pF, S2 closed			2500	ns
Receiver Enable from Shutdown to Output Low	t _{ZL(SHDN)}	MAX483/MAX487, Figures 5 and 11, C _L = 15pF, S1 closed			2500	ns

MAX481/MAX483/MAX485/MAX487–MAX491/MAX1487

低功耗、限摆率、RS-485/RS-422收发器

NOTES FOR ELECTRICAL/SWITCHING CHARACTERISTICS

- Note 1:** All currents into device pins are positive; all currents out of device pins are negative. All voltages are referenced to device ground unless otherwise specified.
- Note 2:** All typical specifications are given for $V_{CC} = 5V$ and $T_A = +25^\circ C$.
- Note 3:** Supply current specification is valid for loaded transmitters when $DE = 0V$.
- Note 4:** Applies to peak current. See *Typical Operating Characteristics*.
- Note 5:** The MAX481/MAX483/MAX487 are put into shutdown by bringing \overline{RE} high and DE low. If the inputs are in this state for less than 50ns, the parts are guaranteed not to enter shutdown. If the inputs are in this state for at least 600ns, the parts are guaranteed to have entered shutdown. See *Low-Power Shutdown Mode (MAX481/MAX483/MAX487)* section.

典型工作特性

($V_{CC} = 5V$, $T_A = +25^\circ C$, unless otherwise noted.)

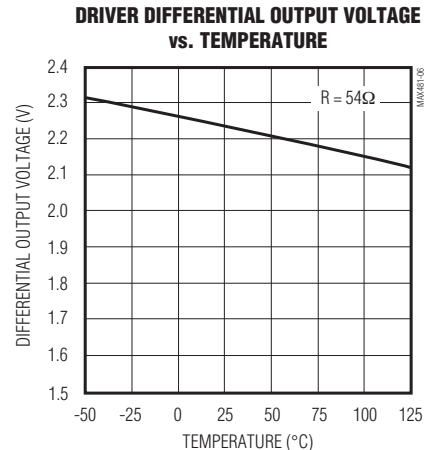
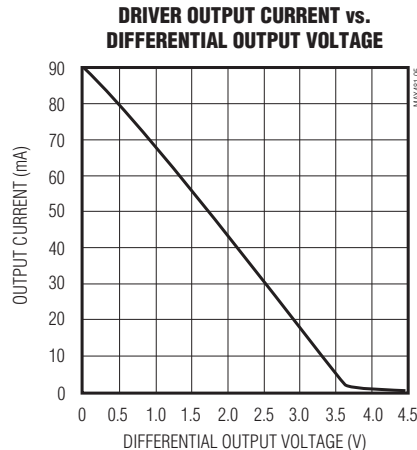
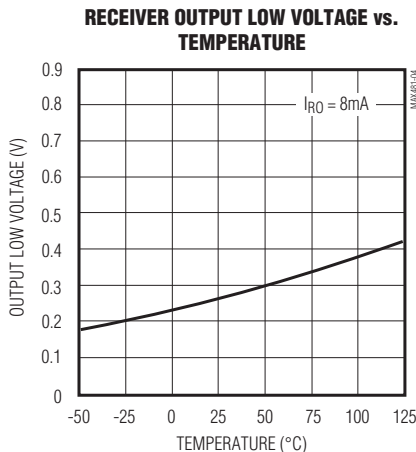
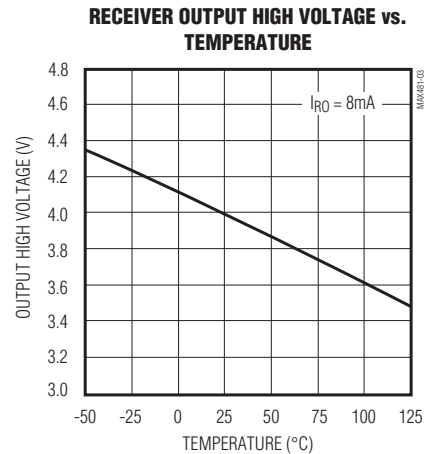
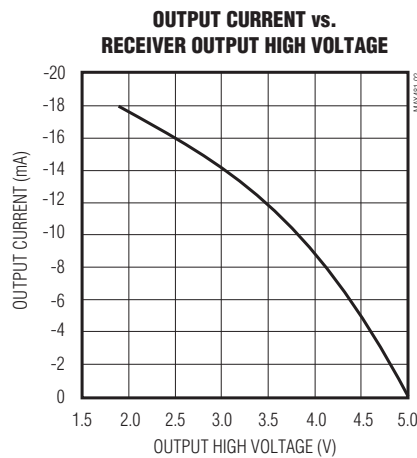
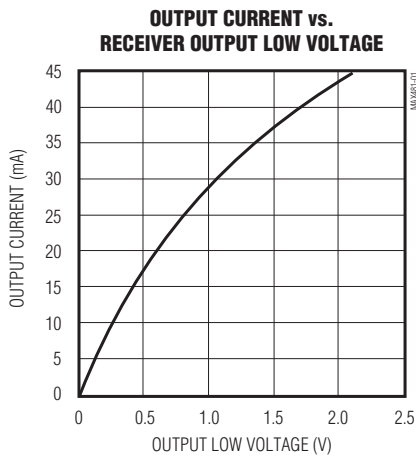

MAX481/MAX483/MAX485/MAX487-MAX491/MAX1487

低功耗、限摆率、RS-485/RS-422收发器

典型工作特性(续)

($V_{CC} = 5V$, $T_A = +25^\circ C$, unless otherwise noted.)

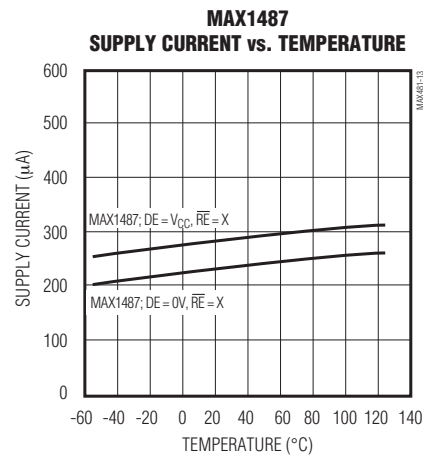
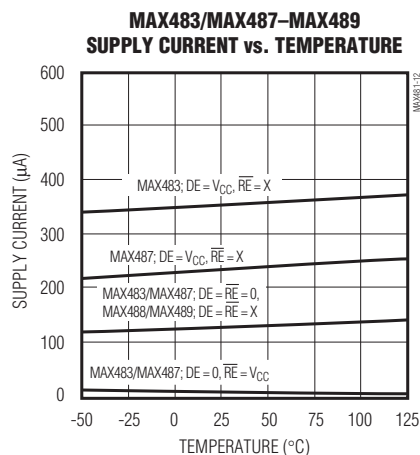
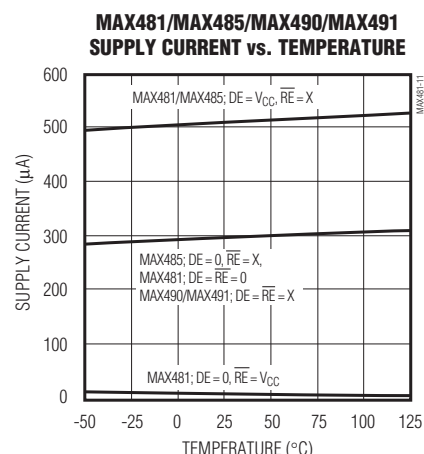
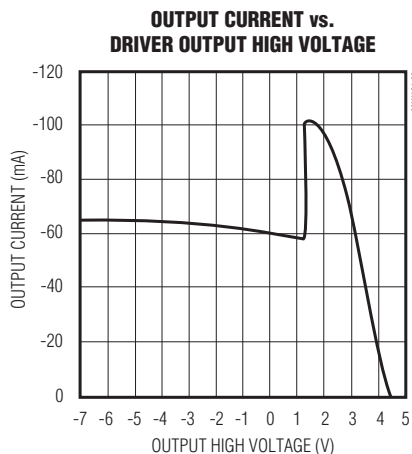
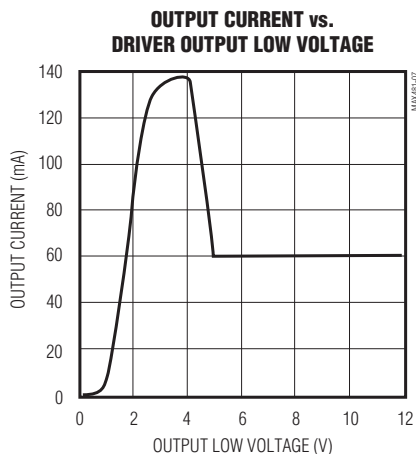

MAX481/MAX483/MAX485/MAX487–MAX491/MAX1487

低功耗、限摆率、 RS-485/RS-422收发器

引脚说明

引脚					名称	功能
MAX481/MAX483/ MAX485/MAX487/ MAX1487		MAX488/ MAX490		MAX489/ MAX491		
DIP/SO	μMAX	DIP/SO	μMAX	DIP/SO		
1	3	2	4	2	RO	接收器输出：若 $A > B$ 200mV，则RO为高电平；若 $A < B$ 200mV，则RO为低电平。
2	4	—	—	3	\overline{RE}	接收器输出使能。当 \overline{RE} 为低电平时，RO有效；当 \overline{RE} 为高电平时，RO为高阻状态。
3	5	—	—	4	DE	驱动器输出使能。DE变为高电平时，驱动器输出Y与Z有效；当DE为低电平时，驱动器输出为高阻状态。当驱动器输出有效时，器件被用作线驱动器。而高阻状态下，若 \overline{RE} 为低电平，则器件被用作线接收器。
4	6	3	5	5	DI	驱动器输入。DI上的低电平强制输出Y为低电平，而输出Z为高电平。同理，DI上的高电平强制输出Y为高电平，而输出Z为低电平。
5	7	4	6	6, 7	GND	地。
—	—	5	7	9	Y	驱动器同相输出端。
—	—	6	8	10	Z	驱动器反相输出端。
6	8	—	—	—	A	接收器同相输入端和驱动器同相输出端。
—	—	8	2	12	A	接收器同相输入端。
7	1	—	—	—	B	接收器反相输入端和驱动器反相输出端。
—	—	7	1	11	B	接收器反相输入端。
8	2	1	3	14	VCC	正电源：4.75V ≤ VCC ≤ 5.25V。
—	—	—	—	1, 8, 13	N.C.	未连接—内部未连接。



图1. MAX481/MAX483/MAX485/MAX487/MAX1487引脚配置与典型工作电路

MAX481/MAX483/MAX485/MAX487–MAX491/MAX1487

低功耗、限摆率、RS-485/RS-422收发器

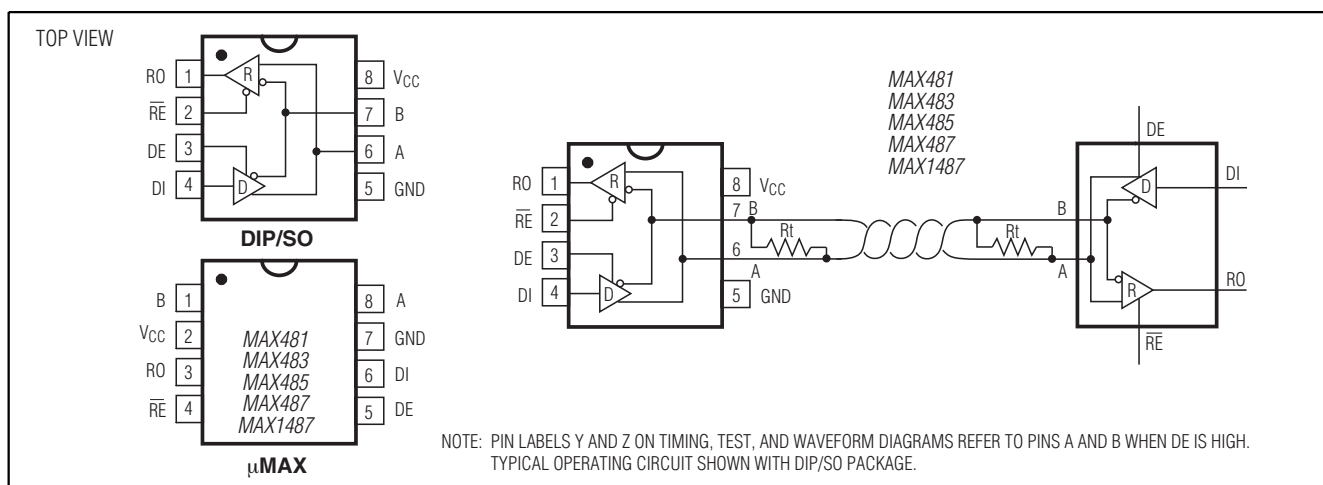

图2. MAX488/MAX490 引脚配置与典型工作电路



图3. MAX489/MAX491 引脚配置与典型工作电路

应用信息

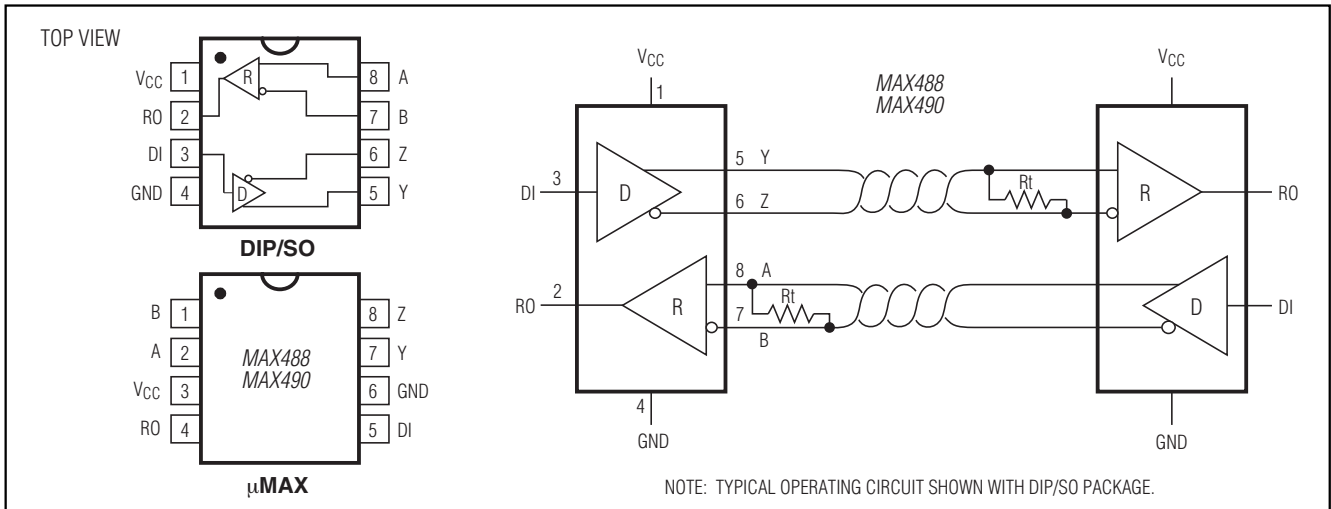
MAX481/MAX483/MAX485/MAX487–MAX491 以及 MAX1487 是用于 RS-485 与 RS-422 通信的低功耗收发器。MAX481、MAX485、MAX490、MAX491 以及 MAX1487 能够以最高 2.5Mbps 的数据速率发送并接收数据；而 MAX483、MAX487、MAX488 以及 MAX489 则用于最高 250kbps 的数据速率。MAX488–MAX491 是全双工收发器，MAX481、MAX483、MAX485、MAX487 以及 MAX1487 是半双工收发器。另外，MAX481、MAX483、MAX485、MAX487、MAX489、MAX491 以及 MAX1487 中包含驱动器使能 (DE) 与接收器使能 (\overline{RE}) 控制引脚，被禁用时，驱动器或接收器输出为高阻态。

MAX487/MAX1487: 总线上可以接 128 个收发器

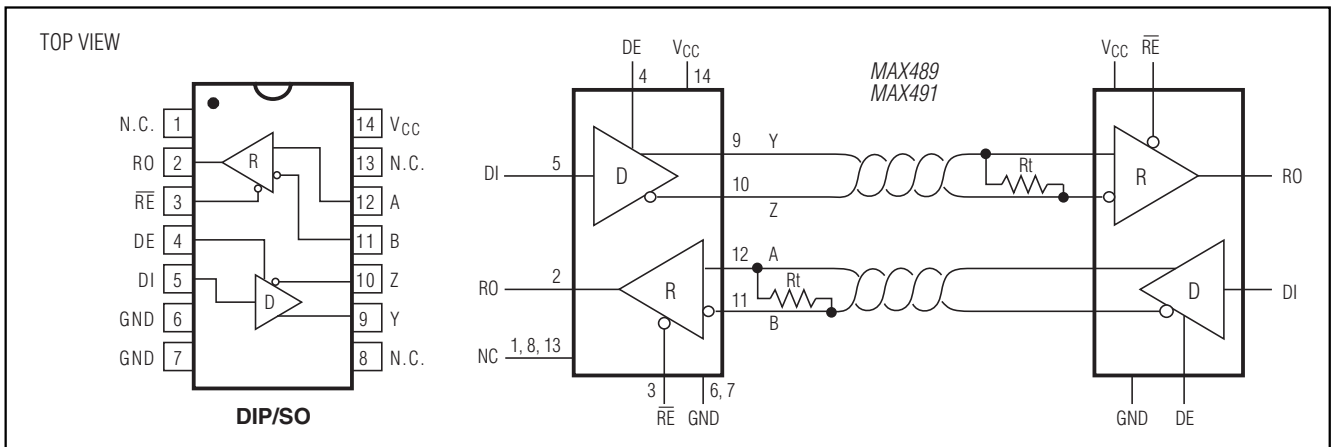
与标准 RS-485 驱动器 (最多 32 个收发器) 的单位负载 (12k Ω 输入阻抗) 相比，MAX487 与 MAX1487 具有 48k Ω 输入电阻，1/4 单位负载的接收器输入阻抗，在一条总线上允许最多挂载 128 个收发器。MAX487/MAX1487 与其他 RS-485 收发器的任意组合可以允许 32 个或更少单位负载连接在同一条总线上。MAX481/MAX483/MAX485 与 MAX488–MAX491 具有标准的 12k Ω 接收器输入阻抗。

MAX481/MAX483/MAX485/MAX487-MAX491/MAX1487

低功耗、限摆率、RS-485/RS-422收发器

测试电路



图4. 驱动器直流测试负载



图5. 接收器时序测试负载

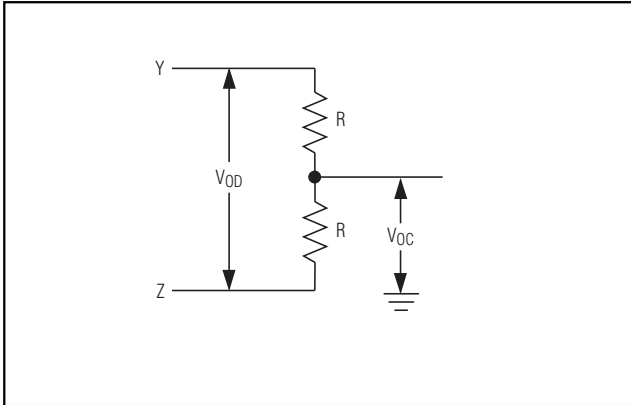

图6. 驱动器/接收器时序测试电路

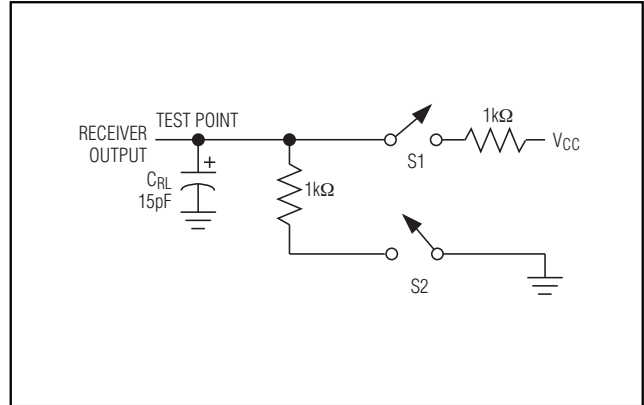

图7. 驱动器时序测试负载

MAX483/MAX487/MAX488/MAX489: 降低EMI和反射

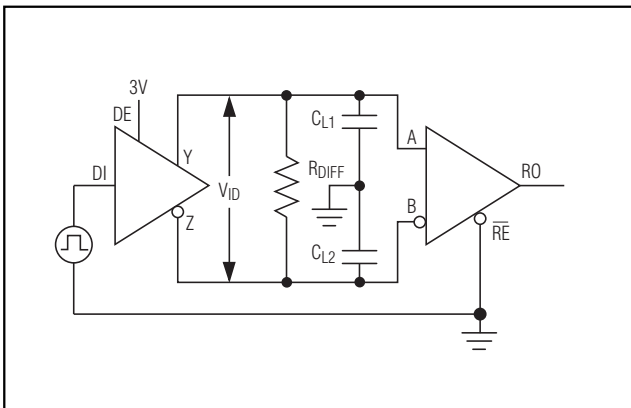
MAX483以及MAX487-MAX489具有摆率限制，可以减小EMI，并降低由不恰当的终端匹配电缆引起的反射。图12给出了驱动器输出波形以及使用MAX481、MAX485、

MAX490、MAX491或MAX1487发送150kHz信号时的傅立叶分析。有明显的大幅值高频谐波。图13给出了MAX483、MAX487、MAX488或MAX489在相同条件下发送数据时的测试结果。图13中的高频谐波幅值要低得多，因此，从根本上抑制了EMI。

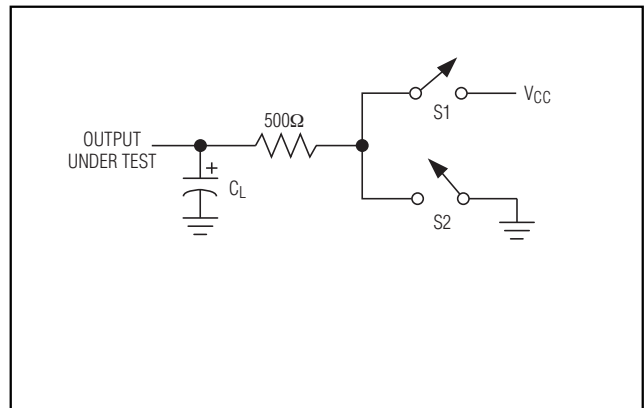
MAX481/MAX483/MAX485/MAX487-MAX491/MAX1487

低功耗、限摆率、RS-485/RS-422收发器

开关波形



图8. 驱动器传输延时



图9. 驱动器使能与禁用时序(MAX488与MAX490例外)

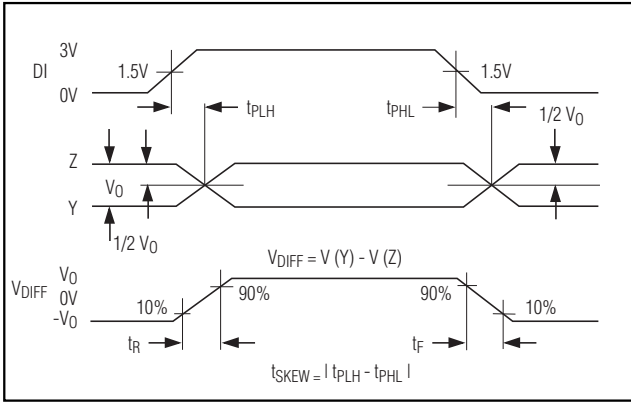

图10. 接收器传输延时

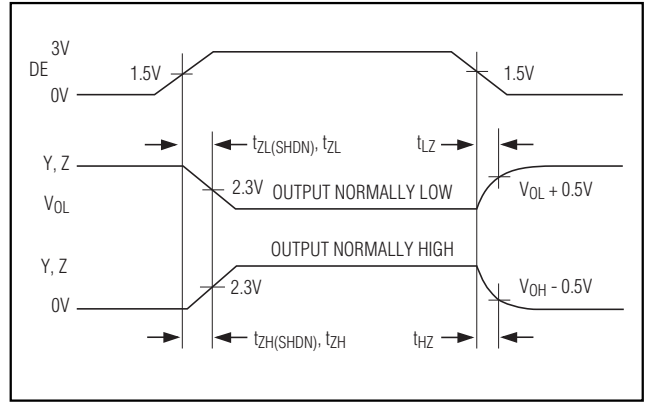

图11. 接收器使能与禁用时序(MAX488与MAX490例外)

功能表(MAX481/MAX483/MAX485/MAX487/MAX1487)

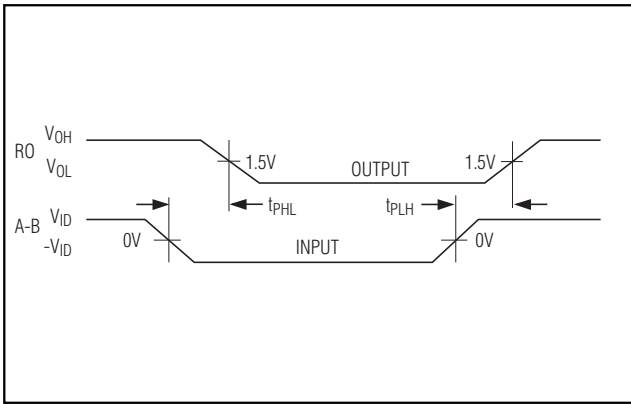
表1. 发送

INPUTS			OUTPUTS	
RE	DE	DI	Z	Y
X	1	1	0	1
X	1	0	1	0
0	0	X	High-Z	High-Z
1	0	X	High-Z*	High-Z*

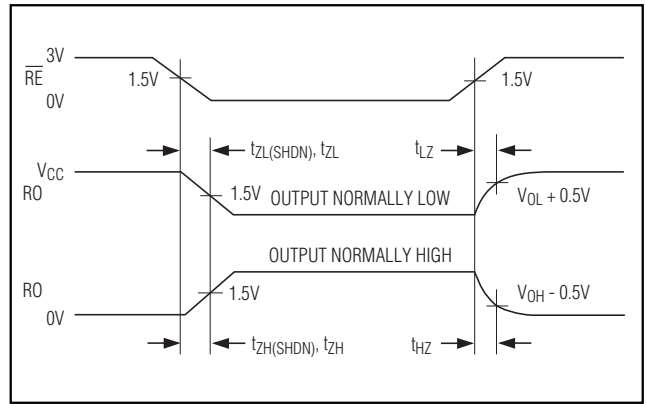
X = 无关。

High-Z = 高阻态。

*MAX481/MAX483/MAX487关断模式。

表2. 接收

INPUTS			OUTPUT
RE	DE	A-B	RO
0	0	$\geq +0.2V$	1
0	0	$\leq -0.2V$	0
0	0	Inputs open	1
1	0	X	High-Z*

X = 无关。

High-Z = 高阻态。

*MAX481/MAX483/MAX487关断模式。

MAX481/MAX483/MAX485/MAX487–MAX491/MAX1487

低功耗、限摆率、RS-485/RS-422收发器



图12. MAX481/MAX485/MAX490/MAX491/MAX1487 发送150kHz信号时的驱动器输出波形与FFT图



图13. MAX483/MAX487–MAX489 发送150kHz信号时的驱动器输出波形与FFT图

低功耗关断模式 (MAX481/MAX483/MAX487)

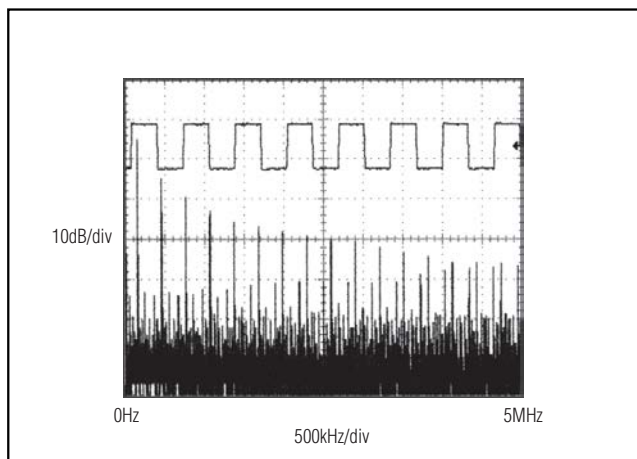
RE高电平、DE低电平使器件进入低功耗关断模式。驱动器与接收器都被禁用时，器件才进入关断模式。关断模式下，器件吸取电源电流的典型值为0.1 μ A。

可以同时驱动RE和DE；只要RE为高电平且DE为低电平的持续时间小于50ns，可以确保这些器件不会进入关断模式。若两个输入端维持这种状态至少600ns，则可确保这些器件进入关断模式。

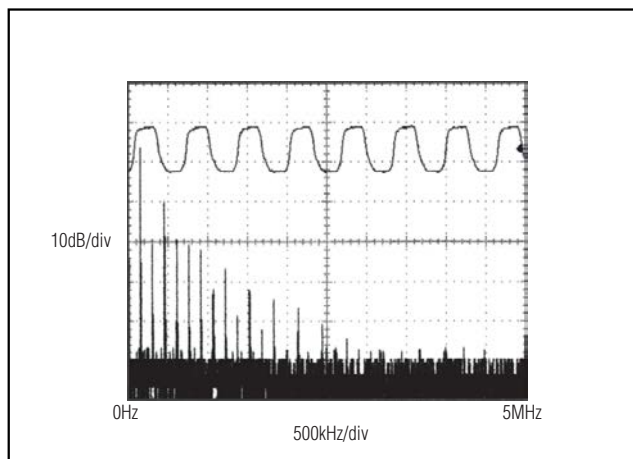
对于MAX481、MAX483与MAX487， t_{ZH} 与 t_{ZL} 使能期间假定器件并未处于低功耗关断状态(MAX485/MAX488–MAX491以及MAX1487不能被关断)。在 $t_{ZH(SHDN)}$ 与 $t_{ZL(SHDN)}$ 使能期间假定器件已被关断(参见*Electrical Characteristics*)。

在低功耗关断状态下激活驱动器和接收器($t_{ZH(SHDN)}$ ， $t_{ZL(SHDN)}$)要比在工作模式下激活驱动器和接收器(t_{ZH} ， t_{ZL})需要更长的时间。(若RE、DE输入等于逻辑0、1或1、1或0、0，则这些器件处于工作模式。)

驱动器输出保护

可以通过两种机制避免由故障或总线冲突引起的过高的输出电流与功耗。输出级的折返式电流限制在整个共模电压范围(参见*典型工作特性*)内提供短路保护。另外，当管芯温度上升过高时，热关断电路强制驱动器输出进入高阻态。

传输延时

许多数字编码方案都取决于驱动器与接收器传输延时的差别。图15至图18给出了采用图14测试电路得到的传输延时典型值。

接收器延时时间差 $|t_{PLH} - t_{PHL}|$ ，对MAX481、MAX485、MAX490、MAX491以及MAX1487来说，其典型值小于13ns；对MAX483与MAX487–MAX489来说，其典型值小于100ns。

驱动器偏移时间，对MAX481、MAX485、MAX490、MAX491以及MAX1487来说，典型值为5ns(最大值为10ns)；对MAX483与MAX487–MAX489来说，其典型值为100ns(最大值为800ns)。

MAX481/MAX483/MAX485/MAX487-MAX491/MAX1487 低功耗、限摆率、 RS-485/RS-422收发器



图14. 接收器传输延时测试电路



图15. MAX481/MAX485/MAX490/MAX491/MAX1487接收器的 t_{PLH}

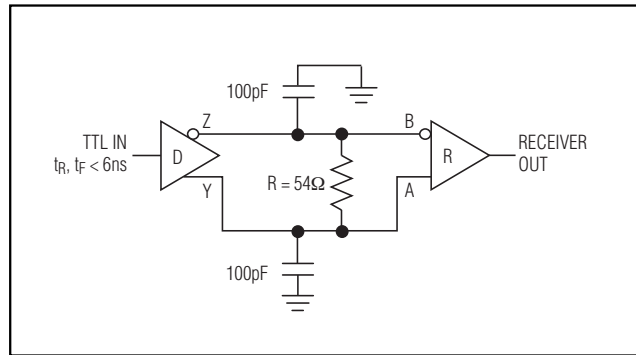

图16. MAX481/MAX485/MAX490/MAX491/MAX1487接收器的 t_{PLH}

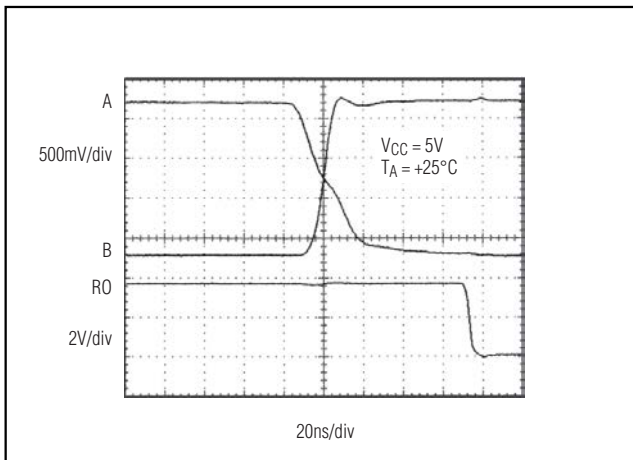

图17. MAX483、MAX487-MAX489接收器的 t_{PLH}

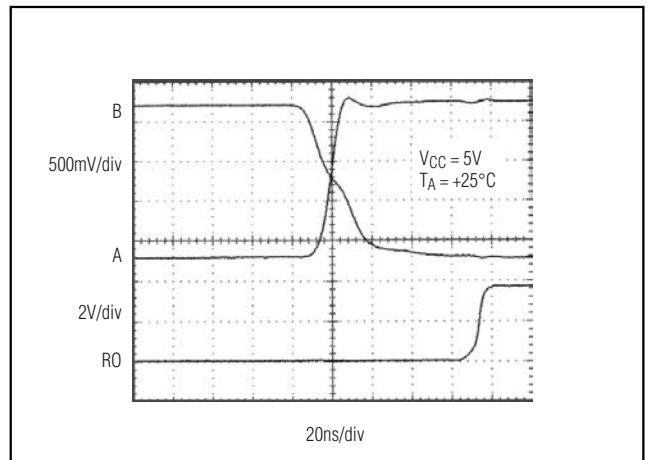

图18. MAX483、MAX487-MAX489接收器的 t_{PLH}

MAX481/MAX483/MAX485/MAX487-MAX491/MAX1487

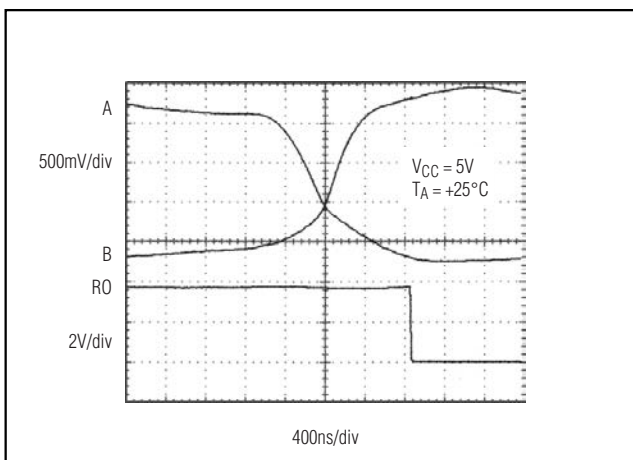
低功耗、限摆率、RS-485/RS-422收发器

传输距离与数据速率

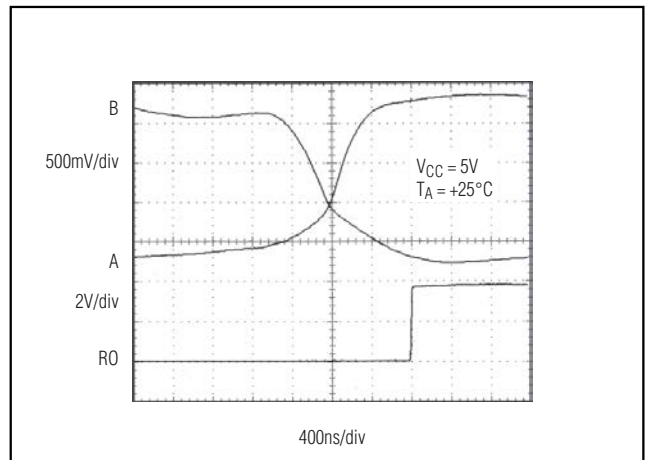
RS-485/RS-422标准覆盖最大4000英尺的传输距离。对大于4000英尺的传输距离，参见图23。

图19与图20给出了器件以110kHz驱动4000英尺26AWG双绞线、120Ω负载时的系统差分电压。

典型应用

MAX481、MAX483、MAX485、MAX487-MAX491以及MAX1487收发器为多点总线传输线上的双向数据通信而设计。

图21与图22给出了典型网络应用电路。这些器件还可以用作中继器，电缆长度可以超过4000英尺，如图23所示。

为了减小反射，传输线应当在其终端以特征阻抗端接，主干线以外的分支长度应尽可能短。具有摆率限制的MAX483、MAX487-MAX489更可以容忍不完善的终端匹配。



图19. 110kHz下驱动4000英尺电缆，MAX481/MAX485/MAX490/MAX491/MAX1487的系统差分电压



图20. 110kHz下驱动4000英尺电缆，MAX483、MAX487-MAX489的系统差分电压

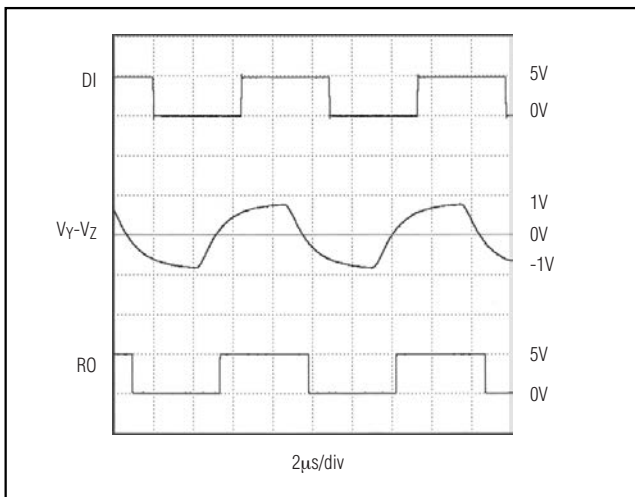

图21. MAX481/MAX483/MAX485/MAX487/MAX1487典型半双工RS-485网络

MAX481/MAX483/MAX485/MAX487-MAX491/MAX1487

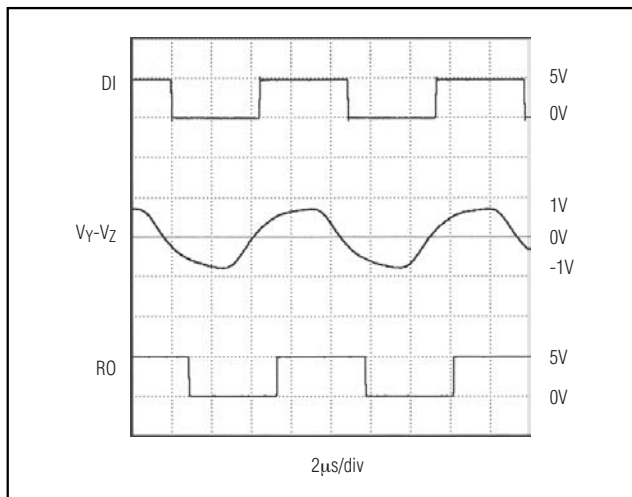
低功耗、限摆率、RS-485/RS-422收发器

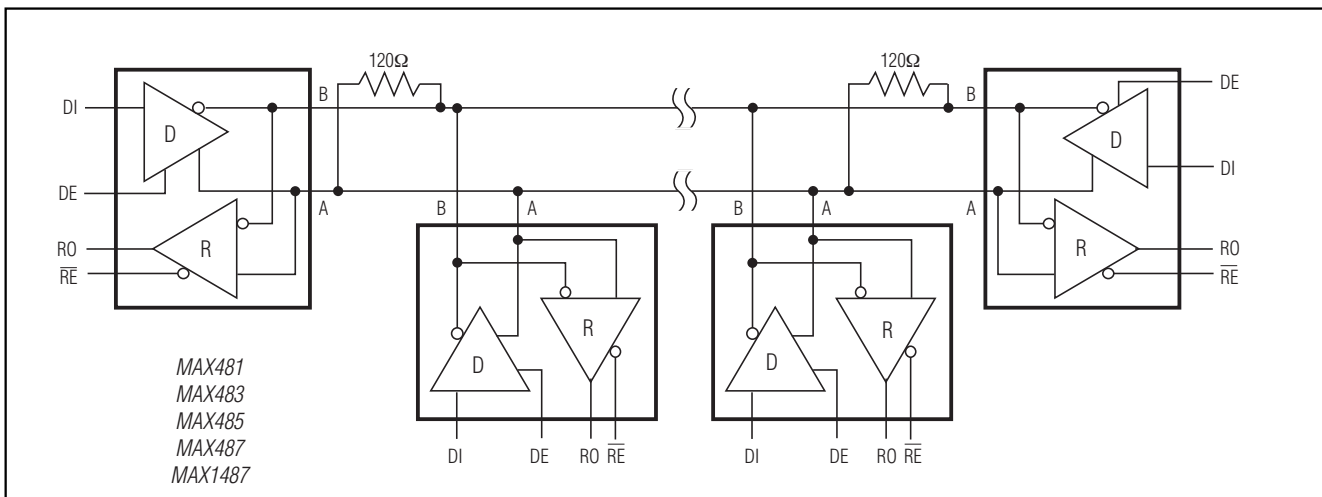

图22. MAX488-MAX491 全双工RS-485网络



图23. MAX488-MAX491 构成的中继器

隔离的RS-485

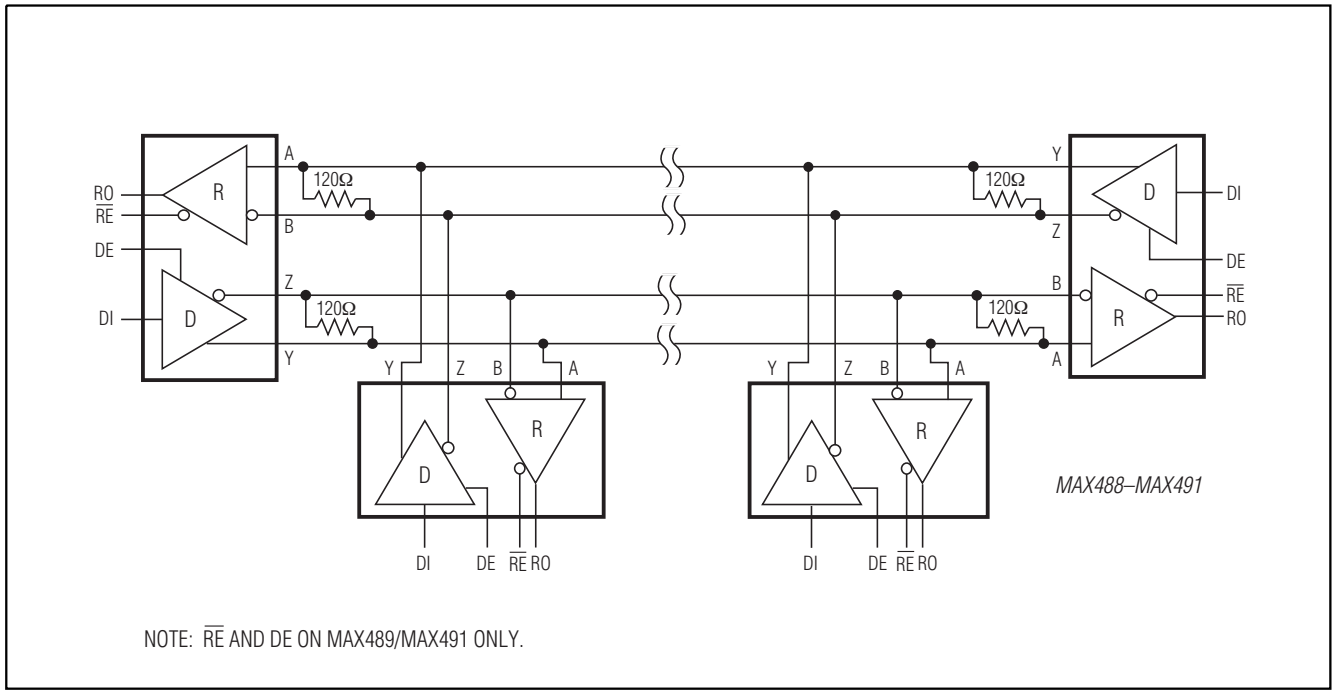
对于隔离的RS-485应用，参见MAX253与MAX1480数据资料。

MAX481/MAX483/MAX485/MAX487–MAX491/MAX1487

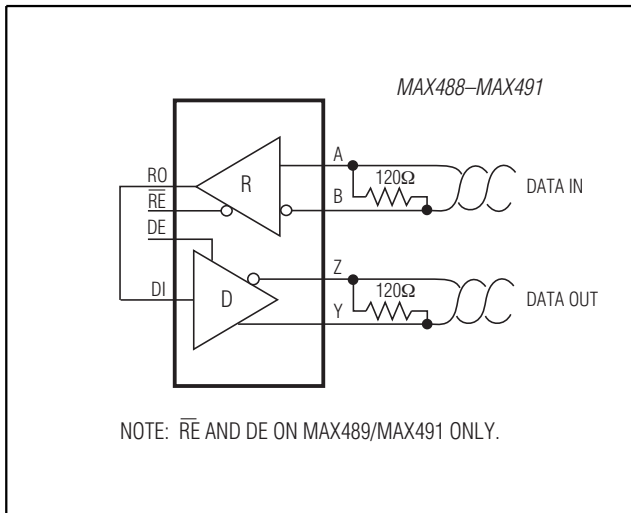
低功耗、限摆率、 RS-485/RS-422收发器

订购信息

订购信息(续)

PART	TEMP. RANGE	PIN-PACKAGE
MAX481 CPA	0°C to +70°C	8 Plastic DIP
MAX481CSA	0°C to +70°C	8 SO
MAX481CUA	0°C to +70°C	8 μ MAX
MAX481C/D	0°C to +70°C	Dice*
MAX481EPA	-40°C to +85°C	8 Plastic DIP
MAX481ESA	-40°C to +85°C	8 SO
MAX481MJA	-55°C to +125°C	8 CERDIP
MAX483 CPA	0°C to +70°C	8 Plastic DIP
MAX483CSA	0°C to +70°C	8 SO
MAX483CUA	0°C to +70°C	8 μ MAX
MAX483C/D	0°C to +70°C	Dice*
MAX483EPA	-40°C to +85°C	8 Plastic DIP
MAX483ESA	-40°C to +85°C	8 SO
MAX483MJA	-55°C to +125°C	8 CERDIP
MAX485 CPA	0°C to +70°C	8 Plastic DIP
MAX485CSA	0°C to +70°C	8 SO
MAX485CUA	0°C to +70°C	8 μ MAX
MAX485C/D	0°C to +70°C	Dice*
MAX485EPA	-40°C to +85°C	8 Plastic DIP
MAX485ESA	-40°C to +85°C	8 SO
MAX485MJA	-55°C to +125°C	8 CERDIP
MAX487 CPA	0°C to +70°C	8 Plastic DIP
MAX487CSA	0°C to +70°C	8 SO
MAX487CUA	0°C to +70°C	8 μ MAX
MAX487C/D	0°C to +70°C	Dice*
MAX487EPA	-40°C to +85°C	8 Plastic DIP
MAX487ESA	-40°C to +85°C	8 SO
MAX487MJA	-55°C to +125°C	8 CERDIP
MAX488 CPA	0°C to +70°C	8 Plastic DIP
MAX488CSA	0°C to +70°C	8 SO
MAX488CUA	0°C to +70°C	8 μ MAX
MAX488C/D	0°C to +70°C	Dice*
MAX488EPA	-40°C to +85°C	8 Plastic DIP
MAX488ESA	-40°C to +85°C	8 SO
MAX488MJA	-55°C to +125°C	8 CERDIP
MAX489 CPD	0°C to +70°C	14 Plastic DIP
MAX489CSD	0°C to +70°C	14 SO
MAX489C/D	0°C to +70°C	Dice*
MAX489EPD	-40°C to +85°C	14 Plastic DIP
MAX489ESD	-40°C to +85°C	14 SO
MAX489MJD	-55°C to +125°C	14 CERDIP

PART	TEMP. RANGE	PIN-PACKAGE
MAX490 CPA	0°C to +70°C	8 Plastic DIP
MAX490CSA	0°C to +70°C	8 SO
MAX490CUA	0°C to +70°C	8 μ MAX
MAX490C/D	0°C to +70°C	Dice*
MAX490EPA	-40°C to +85°C	8 Plastic DIP
MAX490ESA	-40°C to +85°C	8 SO
MAX490MJA	-55°C to +125°C	8 CERDIP
MAX491 CPD	0°C to +70°C	14 Plastic DIP
MAX491CSD	0°C to +70°C	14 SO
MAX491C/D	0°C to +70°C	Dice*
MAX491EPD	-40°C to +85°C	14 Plastic DIP
MAX491ESD	-40°C to +85°C	14 SO
MAX491MJD	-55°C to +125°C	14 CERDIP
MAX1487 CPA	0°C to +70°C	8 Plastic DIP
MAX1487CSA	0°C to +70°C	8 SO
MAX1487CUA	0°C to +70°C	8 μ MAX
MAX1487C/D	0°C to +70°C	Dice*
MAX1487EPA	-40°C to +85°C	8 Plastic DIP
MAX1487ESA	-40°C to +85°C	8 SO
MAX1487MJA	-55°C to +125°C	8 CERDIP

*关于裸片的规格, 请与工厂联系。

芯片拓扑

MAX481/MAX483/MAX485/MAX487/MAX1487

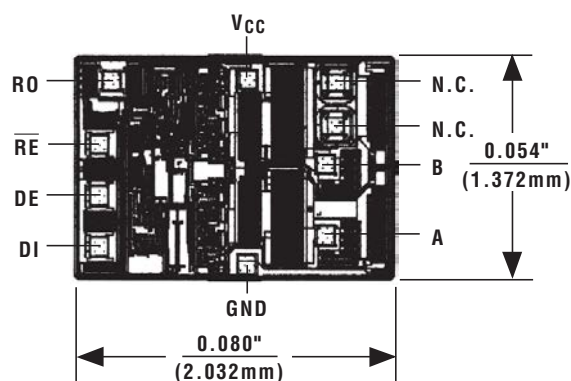

MAX481/MAX483/MAX485/MAX487–MAX491/MAX1487

低功耗、限摆率、RS-485/RS-422收发器

芯片拓扑(续)

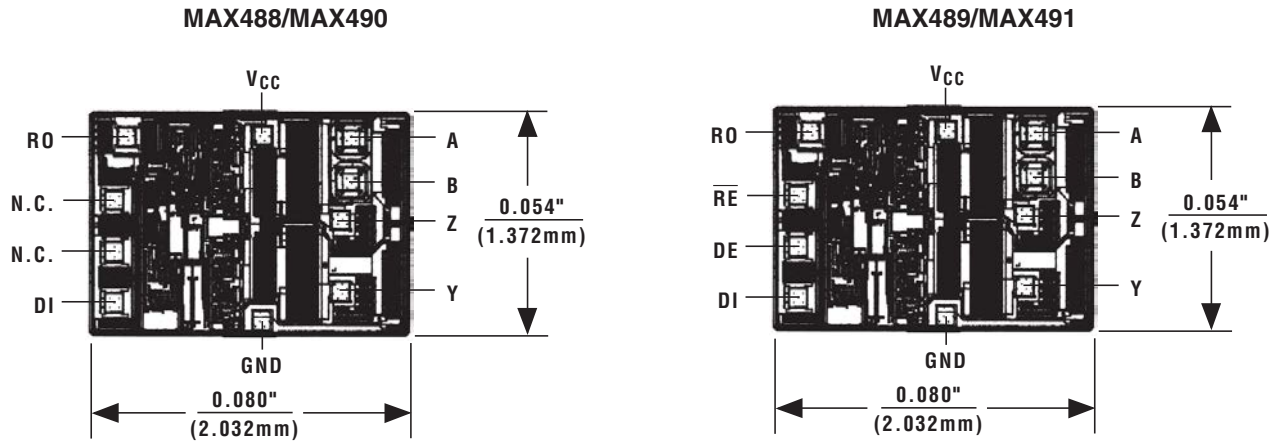

TRANSISTOR COUNT: 248
SUBSTRATE CONNECTED TO GND

封装信息

如需最近的封装外形信息和焊盘布局, 请查询 china.maxim-ic.com/packages。请注意, 封装编码中的“+”、“#”或“-”仅表示RoHS状态。封装图中可能包含不同的尾缀字符, 但封装图只与封装有关, 与RoHS状态无关。

封装类型	封装编码	文档编号
8引脚塑封DIP	P8-1	21-0043
8 SO	S8-2	21-0041
8 μ MAX	U8-1	21-0036
8 CERDIP	J8-2	21-0045
14引脚塑封DIP	P14-3	21-0043
14 SO	S14-1	21-0041
14 CERDIP	J14-3	21-0045

MAX481/MAX483/MAX485/MAX487–MAX491/MAX1487

低功耗、限摆率、 RS-485/RS-422收发器

修订历史

修订次数	修订日期	说明	修改页
0	1/93	最初版本。	—
9	9/09	将选型表中的列标题更改为“Number of Receivers on Bus”。	1

Maxim北京办事处

北京8328信箱 邮政编码100083

免费电话: 800 810 0310

电话: 010-6211 5199

传真: 010-6211 5299



Maxim不对Maxim产品以外的任何电路使用负责，也不提供其专利许可。Maxim保留在任何时间、没有任何通报的前提下修改产品资料和规格的权利。电气特性表中列出的参数值(最小值和最大值)均经过设计验证，数据资料其它章节引用的参数值供设计人员参考。

Maxim Integrated 160 Rio Robles, San Jose, CA 95134 USA 1-408-601-1000

17

X-ON Electronics

Largest Supplier of Electrical and Electronic Components

Click to view similar products for [RS-422/RS-485 Interface IC](#) category:

Click to view products by [Analog Devices](#) manufacturer:

Other Similar products are found below :

[SP3494CN-L/TR](#) [ISL4486IBZ-T](#) [ISL4491EIB](#) [ISL4491EIBZ-T](#) [ISL81483IB](#) [ISL83086EIB](#) [ISL83088EIB](#) [ISL83488IB](#) [ISL8483EIB](#)
[ISL8487EIB](#) [ISL8489EIB](#) [ISL8491IP](#) [ADM489AN](#) [CA-IS3080WX](#) [CA-IS3086WX](#) [NSi83085E-DSWR](#) [SIT65HVD75ETK](#) [GM13487E](#)
[LTC2855IGN#TRPBF](#) [CS48520M](#) [CA-IF4820FD](#) [HSN65HVD12DR](#) [UM3088EESA](#) [SIT490EEPA](#) [ISOW1412BDFMR](#) [MAX485MJA/883B](#)
[MAX13089ECSD+T](#) [CA-IF4888HS](#) [CS485M](#) [CLM3085ESA+](#) [CLM485ESA+](#) [CLM485EESA+](#) [CLM3085EESA+](#) [CS4585EO](#) [DW3085](#)
[WS3471EEUA](#) [WS3079](#) [MS2583](#) [H485EIMM/TR](#) [SP3485EN-HXY](#) [SP3483EN-HXY](#) [ST3485EBDR-HXY](#) [MAX1487ESA-HXY](#)
[MAX3483ESA-HXY](#) [MAX487ESA-HXY](#) [SP485EN-HXY](#) [SN75LBC184DR-HXY](#) [MAX485EESA-HXY](#) [SN65LBC184N-HXY](#) [SN75176N-](#)
[HXY](#)