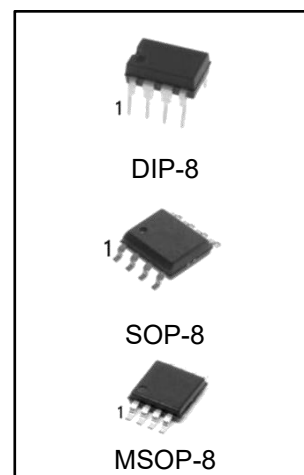


## DC-to- DC Converter Control Circuits

### FEATURES

- Operation from 3.0V to 40V input
- Low standby current
- Current limiting
- Output switch current up to 1.5A
- Adjustable output voltage
- Operation at frequencies up to 100kHz
- Precision reference (2%)



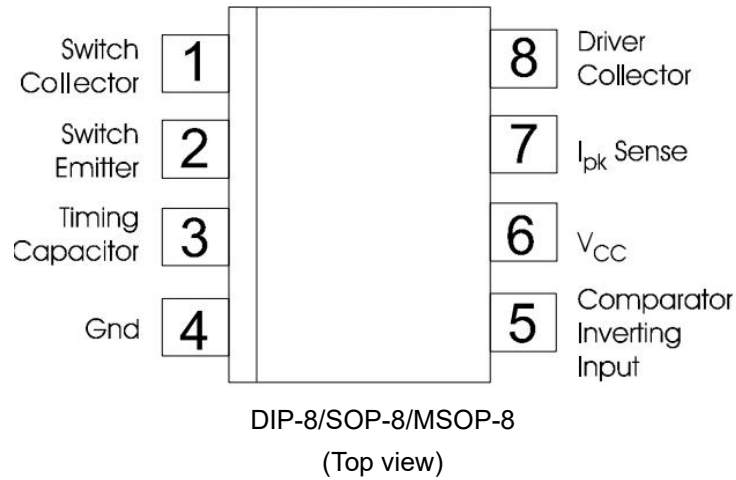
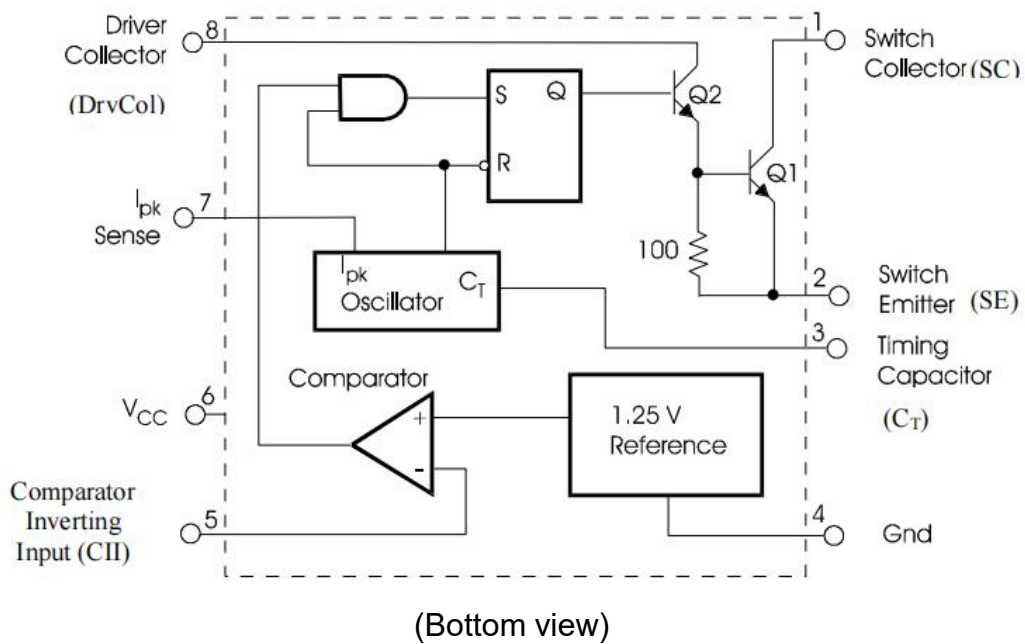
### ORDERING INFORMATION

DEVICE	Package Type	MARKING	Packing	Packing Qty
MC33063P	DIP-8	MC33063	TUBE	2000pcs/box
MC33063DRG	SOP-8	MC33063	REEL	2500pcs/reel
MC33063DGKRG	MSOP-8	33063	REEL	2500pcs/reel

### DESCRIPTION

The MC33063 series is a monolithic control circuit containing primary functions required for DC-to-DC converters.

These devices consist of an internal temperature-compensated reference, comparator, controlled duty cycle oscillator with an active current limit circuit, driver and high current output switch. This series was specifically designed to be incorporated in step-down and step-up and voltage-inverting applications with a minimum number of external components.

**PIN CONNECTIONS**

**SCHEMATIC DIAGRAM**


## ABSOLUTE MAXIMUM RATINGS

Rating	Symbol	Value	Unit
Power supply voltage	$V_{CC}$	40	V
Comparator input voltage range	$V_{IR}$	-0.3 to +40	V
Switch collector voltage	$V_{C(Switch)}$	40	V
Switch emitter voltage ( $V_{Pin1}=40V$ )	$V_{E(Switch)}$	40	V
Switch collector-to-emitter voltage	$V_{CE(Switch)}$	40	V
Driver collector voltage	$V_{C(Driver)}$	40	V
Driver collector current (Note 1)	$I_{C(Driver)}$	100	mA
Switch current	$I_{Sw}$	1.5	A
Operating junction temperature	$T_J$	+150	°C
Operating ambient temperature range	$T_A$	-40 to +85	°C
Storage temperature range	$T_{STG}$	-65 to +150	°C
ESD (HBM)		2500	V
Lead Temperature (Soldering, 10 seconds)	$T_L$	245	°C

**Note:** Absolute Maximum Ratings indicate limits beyond which damage to the device may occur. Operating Ratings indicate conditions for which the device is intended to be functional, but specific performance is not ensured.

## ELECTRICAL CHARACTERISTICS ( $V_{CC}=5.0V$ , $T_A=T_{Low}$ to $T_{High}$ , unless otherwise specified.)

Characteristics	Symbol	Min	Typ	Max	Unit
<b>OSCILLATOR</b>					
Frequency ( $V_{Pin5}=0V$ , $C_T=1.0nF$ , $T_A=25^\circ C$ )	fosc	24	33	42	kHz
Charge current ( $V_{CC}=5.0V$ to $40V$ , $T_A=25^\circ C$ )	Ichg	24	35	42	$\mu A$
Discharge current ( $V_{CC}=5.0V$ to $40V$ , $T_A=25^\circ C$ )	Idischg	140	220	260	$\mu A$
Discharge-to-charge current ratio (Pin7 to $V_{CC}$ , $T_A=25^\circ C$ )	Idischg/Ichg	5.2	6.5	7.5	-
Current limit sense voltage (Ichg=Idischg, $T_A=25^\circ C$ )	Vlpk(sense)	250	300	350	mV
<b>OUTPUT SWITCH (Note 2)</b>					
Saturation voltage, Darlington connection $I_{Sw}=1.0A$ , Pins1, 8 connected	$V_{CE(sat)}$	-	1.0	1.3	V
Saturation voltage, Darlington connection ( $I_{Sw}=1.0A$ , $R_{Pin8}=82\Omega$ to $V_{CC}$ , forced $\beta=20$ )	$V_{CE(sat)}$	-	0.45	0.7	V
DC current gain ( $I_{Sw}=1.0A$ , $V_{CE}=5.0$ , $T_A=25^\circ C$ )	$h_{FE}$	50	75	-	-
Collector off-state current ( $V_{CE}=40V$ )	$I_{C(off)}$	-	1.0	100	$\mu A$
<b>COMPARATOR</b>					
Threshold voltage	$V_{th}$	1.225 1.21	1.25 -	1.275 1.29	V
Threshold voltage line regulation ( $V_{CC}=3.0V$ to $40V$ )	Reg <sub>line</sub>	-	1.4	5.0	mV
Input bias current ( $V_{in}=0V$ )	$I_{IB}$	-	-20	-400	nA
<b>TOTAL DEVICE</b>					
Supply current ( $V_{CC}=5.0V$ to $40V$ , $C_T=1.0nF$ , Pin7= $V_{CC}$ , $V_{Pin5}>V_{th}$ , Pin2 =Gnd, remaining pins - open)	$I_{CC}$	-	-	4.0	mA

Notes: 1. Maximum package power dissipation limits must be observed.

2. Low duty cycle pulse techniques are used during the test to maintain the junction temperature as close to the ambient temperature as possible.

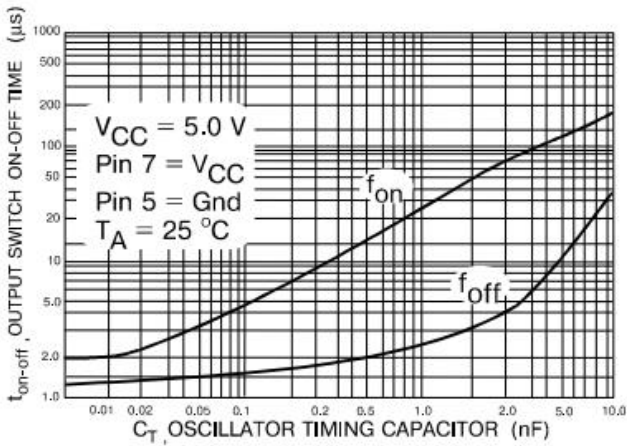
**TYPICAL PERFORMANCE CHARACTERISTICS**


Fig.1. Output Switch on-off time versus Oscillator timing capacitor

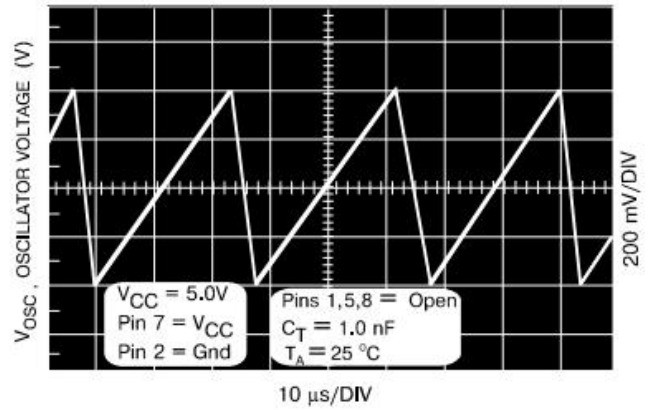


Fig.2. Timing capacitor waveform

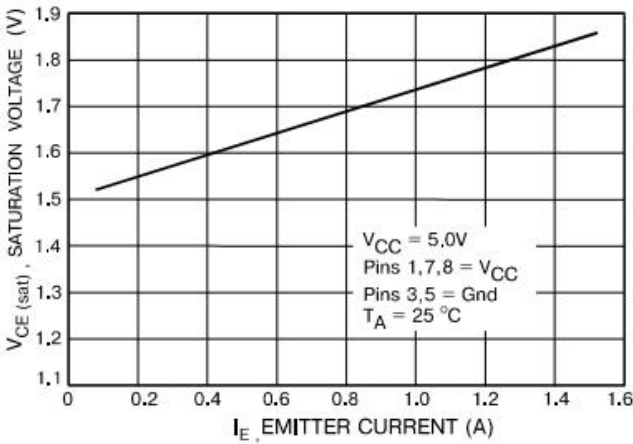


Fig.3. Emitter follower configuration output saturation voltage versus Emitter current

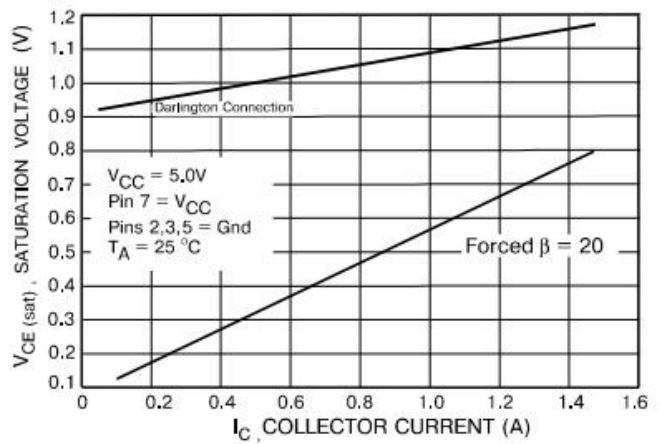


Fig.4. Common emitter configuration output saturation voltage versus Collector current

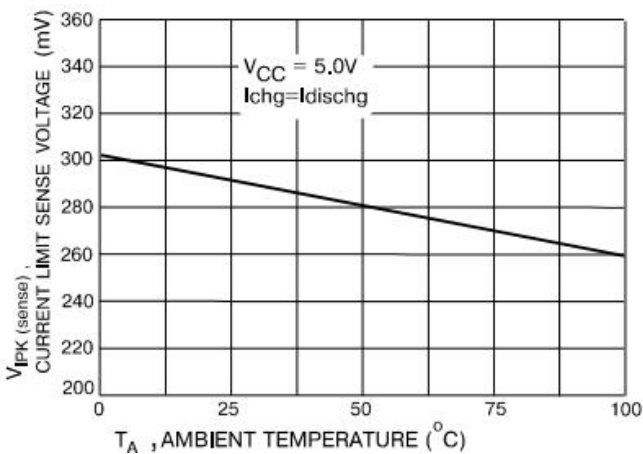


Fig.5. Current limit sense voltage versus Temperature

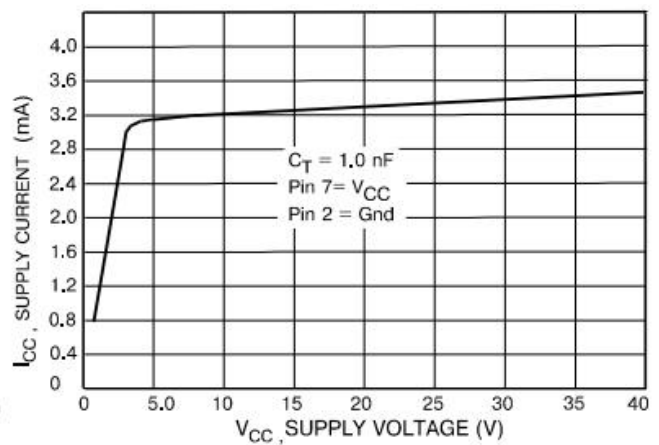
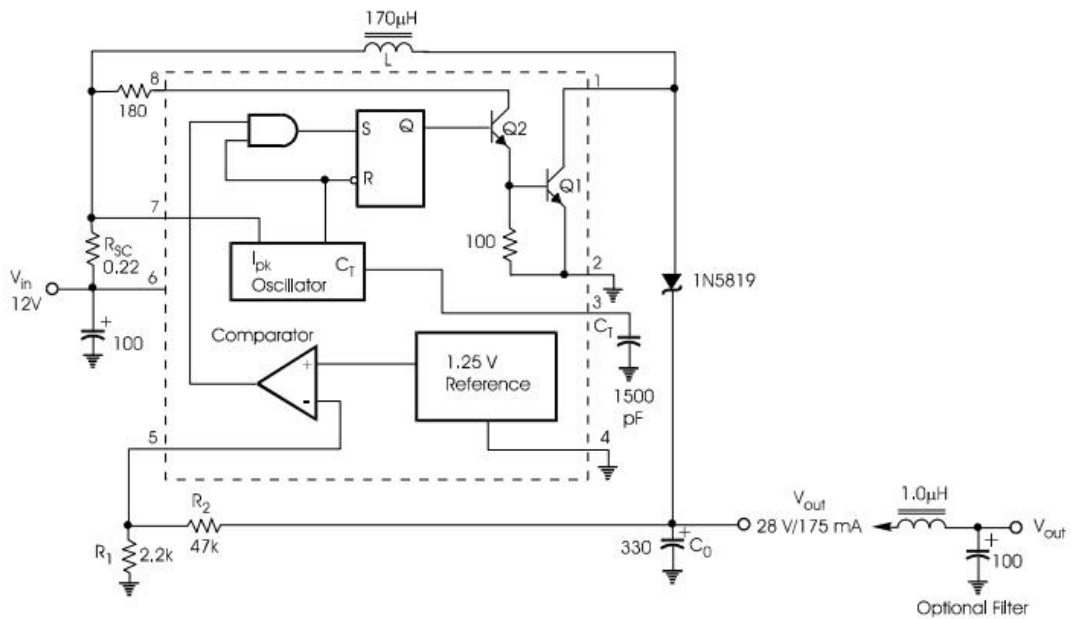
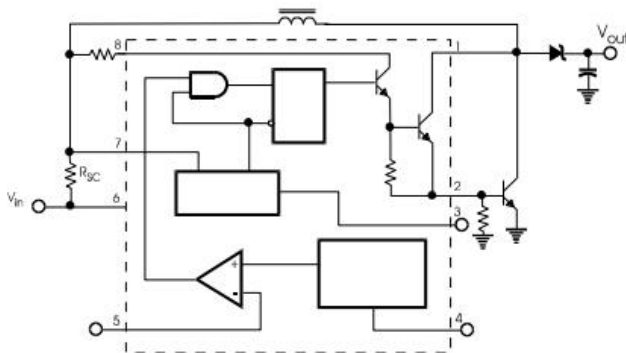
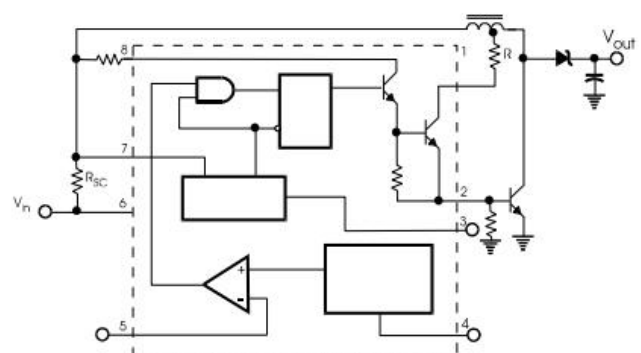


Fig.6. Standby supply current versus Supply voltage

**APPLICATION INFORMATION**
**Fig.1. Step-up converter**

**Fig.2. External current boost connections for IC Peak greater than 1.5A**
**2a. External NPN switch**

**2b. External NPN saturated switch**


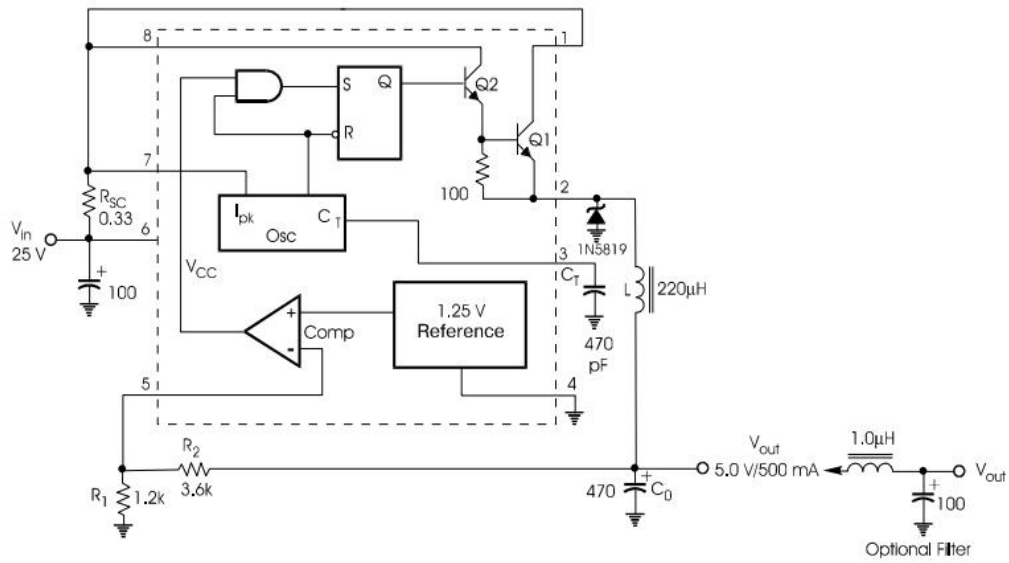
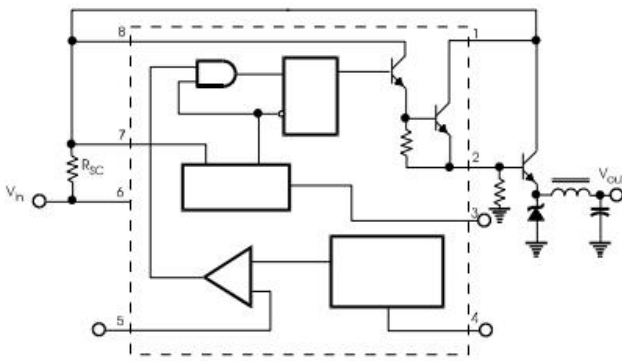
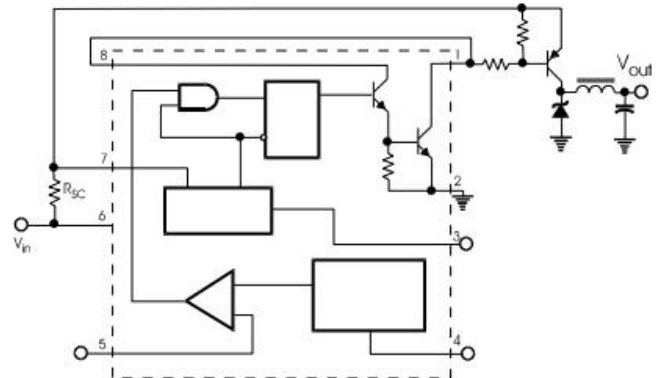
**Fig.3. Step-down Converter**

**Fig.4. External current boost connections for  $I_{C\ Peak}$  greater than 1.5A**
**4a. External NPN switch**

**4b. External PNP saturated switch**


Fig.5. Voltage inverting converter

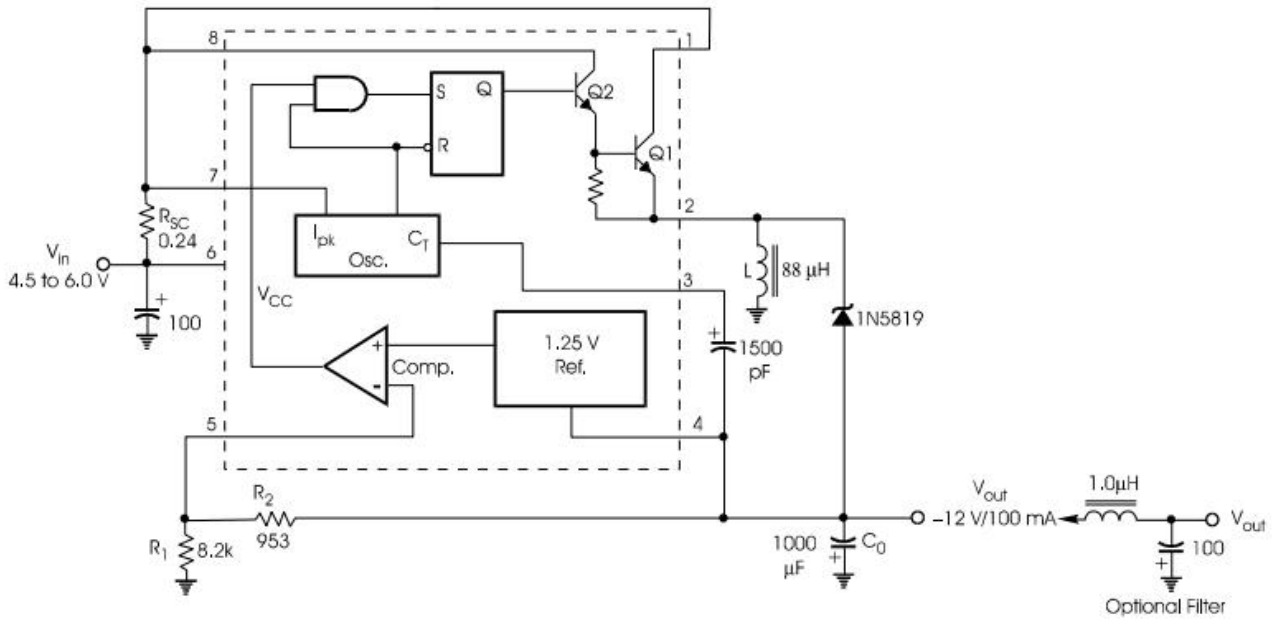
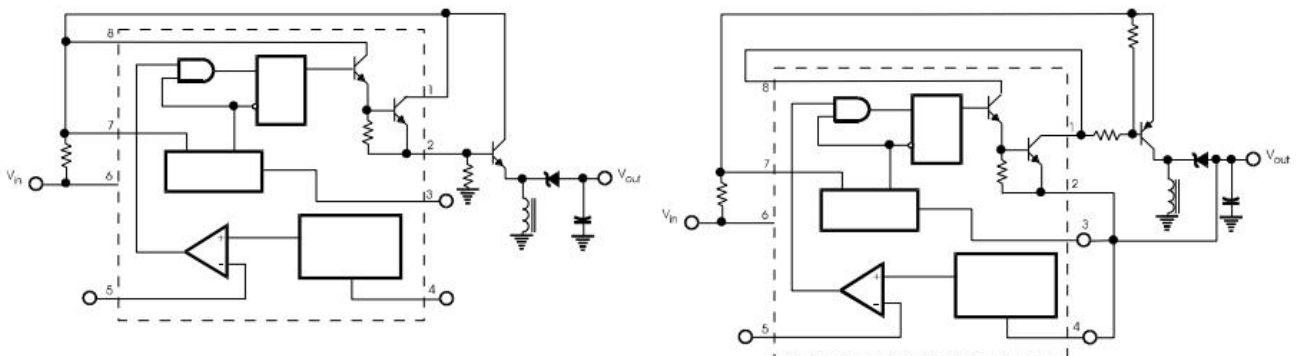


Fig.6. External current boost connections for Ic Peak greater than 1.5A

6a. External NPN switch

6b. External PNP saturated switch



**DESIGN FORMULA**

Calculation	Step-up	Step-down	Voltage-inverting
$t_{on}$	$\frac{V_{out} + V_F - V_{in(min)}}{V_{in(min)} - V_{sat}}$	$\frac{V_{out} + V_F}{V_{in(min)} - V_{sat} - V_{out}}$	$\frac{ V_{out}  + V_F}{V_{in} + V_{sat}}$
$(t_{on} + t_{off})_{max}$	$\frac{1}{f_{min}}$	$\frac{1}{f_{min}}$	$\frac{1}{f_{min}}$
$C_T$	$4.0 \times 10^{-5} t_{on}$	$4.0 \times 10^{-5} t_{on}$	$4.0 \times 10^{-5} t_{on}$
$I_{pk(switch)}$	$2I_{out(max)} \left( \frac{t_{on}}{t_{off}} + 1 \right)$	$2I_{out(max)}$	$2I_{out(max)} \left( \frac{t_{on}}{t_{off}} + 1 \right)$
$R_{sc}$	$0.3/I_{pk(Switch)}$	$0.3/I_{pk(Switch)}$	$0.3/I_{pk(Switch)}$
$L(min)$	$\left( \frac{V_{in(min)} - V_{sat}}{I_{pk(switch)}} \right) \times t_{on(max)}$	$\left( \frac{V_{in(min)} - V_{sat} - V_{out}}{I_{pk(switch)}} \right) \times t_{on(max)}$	$\left( \frac{V_{in(min)} - V_{sat}}{I_{pk(switch)}} \right) \times t_{on(max)}$
$C_o$	$9 \frac{I_{out} t_{on}}{V_{ripple(pp)}}$	$\frac{I_{pk(switch)}(t_{on} + t_{off})}{8V_{ripple(pp)}}$	$9 \frac{I_{out} t_{on}}{V_{ripple(pp)}}$

**TERMS AND DEFINITIONS**

$V_{sat}$  – Saturation voltage of the output switch.

$V_F$  – Forward voltage drop of the output rectifier.

**The following power supply characteristics must be chosen:**

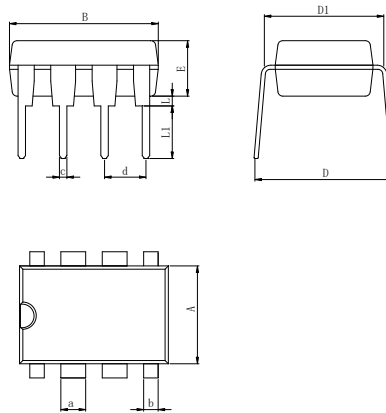
$V_{in}$  – Nominal input voltage.

$V_{out}$  – Desired output voltage,  $|V_{out}| = 1.25 \left( 1 + \frac{R_2}{R_1} \right)$

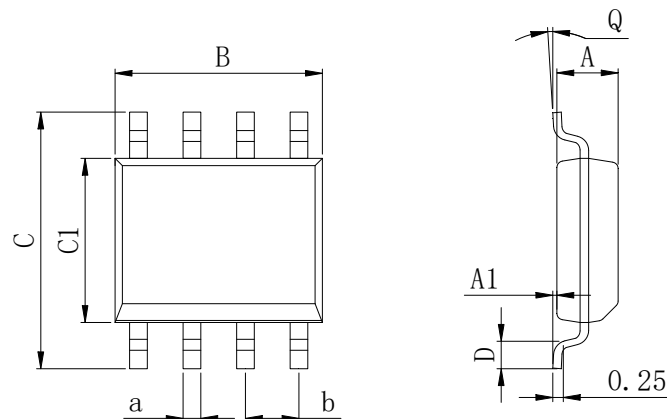
$f_{min}$  – Minimum desired output switching frequency at the selected values of  $V_{in}$  and  $I_{out}$ .

$V_{ripple(p-p)}$  – Desired peak-to-peak output ripple voltage. In practice, the calculated capacitor value will need to be increased due to its equivalent series resistance and board layout. The ripple voltage should be kept to a low value since it will directly affect the line and load regulation.



**PHYSICAL DIMENSIONS**
**DIP-8**


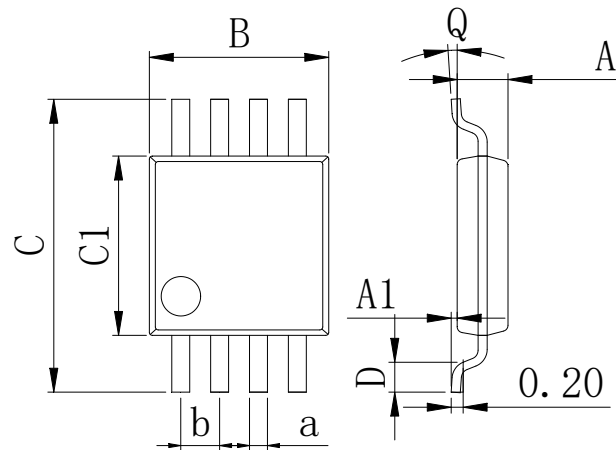
Dimensions In Millimeters(DIP-8)											
Symbol:	A	B	D	D1	E	L	L1	a	b	c	d
Min:	6.10	9.00	8.10	7.42	3.10	0.50	3.00	1.50	0.85	0.40	2.54 BSC
Max:	6.68	9.50	10.9	7.82	3.55	0.70	3.60	1.55	0.90	0.50	

**SOP-8 (150mil)**


Dimensions In Millimeters(SOP-8)									
Symbol:	A	A1	B	C	C1	D	Q	a	b
Min:	1.35	0.05	4.90	5.80	3.80	0.40	0°	0.35	1.27 BSC
Max:	1.55	0.20	5.10	6.20	4.00	0.80	8°	0.45	

**PHYSICAL DIMENSIONS**

MSOP-8



Dimensions In Millimeters(MSOP-8)									
Symbol:	A	A1	B	C	C1	D	Q	a	b
Min:	0.80	0.05	2.90	4.75	2.90	0.35	0°	0.25	0.65 BSC
Max:	0.90	0.20	3.10	5.05	3.10	0.75	8°	0.35	

---

**REVISION HISTORY**

DATE	REVISION	PAGE
2014-6-9	New	1-12
2023-9-14	Update encapsulation type 、 Update Lead Temperature 、 Updated DIP-8 dimension、 Add annotation for Maximum Ratings.	1、 3、 9

**IMPORTANT STATEMENT:**

Hanschip Semiconductor reserves the right to change its products and services without notice. Before ordering, the customer shall obtain the latest relevant information and verify whether the information is up to date and complete. Hanschip Semiconductor does not assume any responsibility or obligation for the altered documents.

Customers are responsible for complying with safety standards and taking safety measures when using Hanschip Semiconductor products for system design and machine manufacturing. You will bear all the following responsibilities: select the appropriate Hanschip Semiconductor products for your application; Design, validate and test your application; Ensure that your application meets the appropriate standards and any other safety, security or other requirements. To avoid the occurrence of potential risks that may lead to personal injury or property loss.

Hanschip Semiconductor products have not been approved for applications in life support, military, aerospace and other fields, and Hanschip Semiconductor will not bear the consequences caused by the application of products in these fields. All problems, responsibilities and losses arising from the user's use beyond the applicable area of the product shall be borne by the user and have nothing to do with Hanschip Semiconductor, and the user shall not claim any compensation liability against Hanschip Semiconductor by the terms of this Agreement.

The technical and reliability data (including data sheets), design resources (including reference designs), application or other design suggestions, network tools, safety information and other resources provided for the performance of semiconductor products produced by Hanschip Semiconductor are not guaranteed to be free from defects and no warranty, express or implied, is made. The use of testing and other quality control technologies is limited to the quality assurance scope of Hanschip Semiconductor. Not all parameters of each device need to be tested.

The documentation of Hanschip Semiconductor authorizes you to use these resources only for developing the application of the product described in this document. You have no right to use any other Hanschip Semiconductor intellectual property rights or any third party intellectual property rights. It is strictly forbidden to make other copies or displays of these resources. You should fully compensate Hanschip Semiconductor and its agents for any claims, damages, costs, losses and debts caused by the use of these resources. Hanschip Semiconductor accepts no liability for any loss or damage caused by infringement.

## X-ON Electronics

Largest Supplier of Electrical and Electronic Components

*Click to view similar products for [Isolated DC/DC Converters](#) category:*

*Click to view products by [Analog Devices](#) manufacturer:*

Other Similar products are found below :

[PSL486-7LR](#) [Q48T30020-NBB0](#) [JAHW100Y1](#) [SPB05C-12](#) [SQ24S15033-PS0S](#) [CE-1003](#) [CE-1004](#) [MAU228](#) [J80-0041NL](#) [DFC15U48D15](#)  
[XGS-1205](#) [06322](#) [SPB05B-15](#) [L-DA20](#) [DCG40-5G](#) [XKS-2405](#) [DPA423R](#) [vi-m13-cw-03](#) [VI-L53-CV](#) [24IBX15-50-0ZG](#) [HZZ01204-G](#)  
[SPU02L-09](#) [SPU02M-09](#) [SPU02N-09](#) [QUINT4-BUFFER/24DC/40](#) [QUINT4-CAP/24DC/5/4KJ](#) [73-551-5039I](#) [DFC15U48D15G](#) [SEN-6471-](#)  
[1EM](#) [AHV2815DF/HBB](#) [MI-LC21-IX](#) [PAH-48/8.5-D48NB1-C](#) [BM3020-7A](#) [QRS2050P025R06](#) [QRS2050P025K00](#) [CM2320-9EG](#)  
[SKMW15F-05](#) [V300A28H400BF3](#) [TEN 15-1223](#) [TEQ 100-2418WIR](#) [TEQ 160-7218WIR](#) [R05C05TE05S-R](#) [HQA2W085W033V-N07-S](#)  
[AM1SS-2405SJZ](#) [AM2DS-1224SJZ](#) [AM2DS-2405DJZ](#) [AM10SBO-4824SNZ-B](#) [AM15E-2405S-NZ](#) [AM2DS-1212SJZ](#) [AM30SBO-](#)  
[4805SNZ-B](#)