

Hardware Version V1.4

HARDWARE MANUAL

+



+

+

PD28-1-1021

PD28-3-1021

Stepper Motor NEMA11 / 28mm
0.06 - 0.12Nm
with Controller / Driver
up-to 0.7A RMS / 24V DC
sens0step™ Encoder
RS485 Interface

+

UNIQUE FEATURES:



coolStep™

stallGuard²

TRINAMIC Motion Control GmbH & Co. KG
Hamburg, Germany

www.trinamic.com

TRINAMIC
MOTION CONTROL

Table of Contents

| | | |
|-------|--|----|
| 1 | Features..... | 3 |
| 2 | Order Codes | 5 |
| 3 | Mechanical and Electrical Interfacing..... | 6 |
| 3.1.1 | Dimensions of PD28-1-1021 | 6 |
| 3.1.2 | Dimensions of PD28-3-1021 | 7 |
| 3.2 | Motor Characteristics | 8 |
| 3.3 | Integrated sensOstep™ encoder | 9 |
| 3.4 | Connectors..... | 10 |
| 3.4.1 | Power, Communication and I/O Connector | 11 |
| 3.4.2 | Motor Connector..... | 17 |
| 4 | Motor driver current | 18 |
| 5 | Reset to Factory Defaults..... | 21 |
| 6 | On-board LED..... | 21 |
| 7 | Operational Ratings | 22 |
| 8 | Torque Curves | 24 |
| 9 | Functional description | 25 |
| 10 | Life Support Policy..... | 26 |
| 11 | Revision History..... | 27 |
| 11.1 | Document Revision | 27 |
| 11.2 | Hardware Revision | 27 |
| 12 | References | 28 |

1 Features

The PANdrive™ PD28-1-1021 and PD28-3-1021 are small and compact full mechatronic solutions including NEMA11 / 28mm flange size stepper motors, the TCM-1021 controller/ driver electronics and TRINAMIC sensOstep™ encoder for step-loss detection. The two PANdrives include stepper motor with different lengths and different holding torques (PD28-1-1021: 0.06Nm, PD28-3-1021: 0.12Nm) but, same electronics and encoder setup. The PANdrives support both, stand-alone operation e.g. using the on-board I/Os together with the build-in TMCL scripting feature and remote control operation using the RS485 2-wire communication bus interface and even a mixture of both.

MAIN CHARACTERISTICS

Highlights

- Motion profile calculation in real-time
- On the fly alteration of motor parameters (e.g. position, velocity, acceleration)
- High performance microcontroller for overall system control and serial communication protocol handling
- For position movement applications, where larger motors do not fit and higher torques are not required

Bipolar stepper motor driver

- Up to 256 microsteps per full step
- High-efficient operation, low power dissipation
- Dynamic current control
- Integrated protection
- stallGuard2™ feature for stall detection
- coolStep™ feature for reduced power consumption and heat dissipation

Encoder

- sensOstep magnetic encoder (max. 1024 increments per rotation) e.g. for step-loss detection under all operating conditions and positioning supervision

Interfaces

- Up to 4 multi-purpose inputs (2 shared with outputs)
- 2 general purpose outputs
- RS485 2-wire communication interface

Software

- TMCL: standalone operation or remote controlled operation, program memory (non volatile) for up to 876 TMCL commands, and PC-based application development software TMCL-IDE available for free.

Electrical and mechanical data

- Supply voltage: +24V DC nominal (9... 28V DC)
- Motor current: up to 0.7A RMS (programmable)
- max. holding torque: 0.06Nm (PD28-1-1021) or 0.12Nm (PD28-3-1024)

Refer to separate TMCL Firmware Manual, too.

TRINAMICS UNIQUE FEATURES – EASY TO USE WITH TMCL

stallGuard2™ stallGuard2 is a high-precision sensorless load measurement using the back EMF on the coils. It can be used for stall detection as well as other uses at loads below those which stall the motor. The stallGuard2 measurement value changes linearly over a wide range of load, velocity, and current settings. At maximum motor load, the value goes to zero or near to zero. This is the most energy-efficient point of operation for the motor.

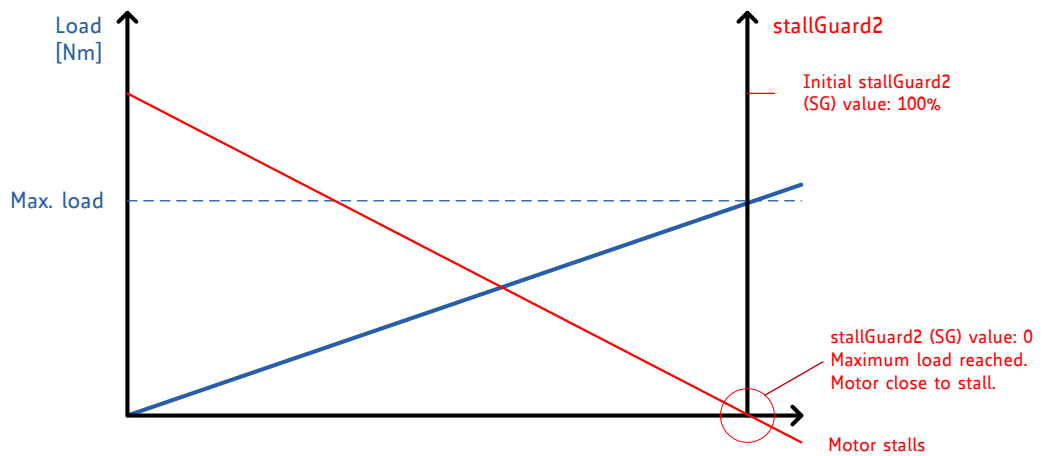

Figure 1.1 stallGuard2 load measurement SG as a function of load

coolStep™ coolStep is a load-adaptive automatic current scaling based on the load measurement via stallGuard2 adapting the required current to the load. Energy consumption can be reduced by as much as 75%. coolStep allows substantial energy savings, especially for motors which see varying loads or operate at a high duty cycle. Because a stepper motor application needs to work with a torque reserve of 30% to 50%, even a constant-load application allows significant energy savings because coolStep automatically enables torque reserve when required. Reducing power consumption keeps the system cooler, increases motor life, and allows reducing cost.

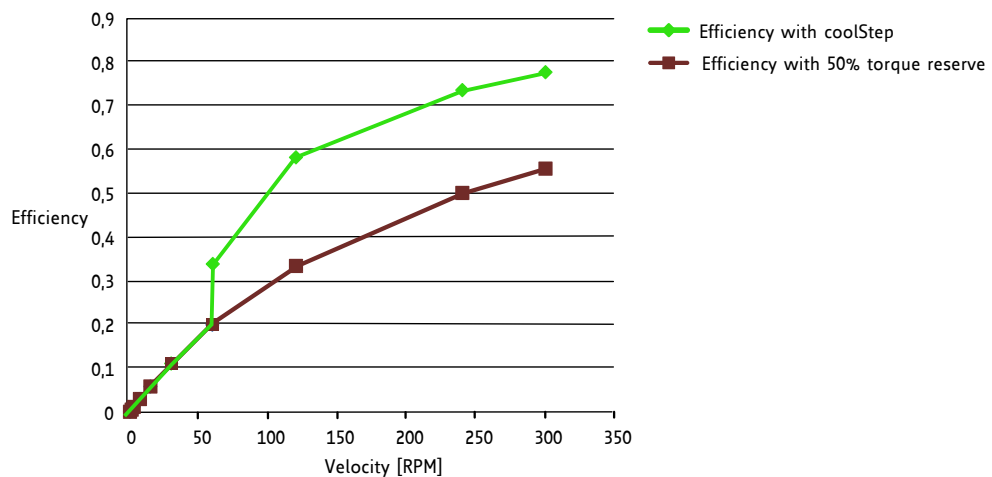

Figure 1.2 Energy efficiency example with coolStep

2 Order Codes

The combination of motor and motor mounted controller/driver electronic is currently available with two stepper motors (different length and holding torque).

The length of the PANdrives™ is specified without the length of the axis. For the overall length of the product please add 21 mm (see detailed drawings in chapter 3).

| Order code | Description | Size of unit [mm ³] |
|--------------------|--|---------------------------------|
| PD28-1-1021-option | PANdrive with NEMA11 stepper motor, 0.06Nm max. holding torque, TCMC-1021 electronics, 0.7A RMS, +24V, RS485, sensOstep™ encoder | 28 x 28 x 43 max. |
| PD28-3-1021-option | PANdrive with NEMA11 stepper motor, 0.12Nm max. holding torque, TCMC-1021 electronics, 0.7A RMS, +24V, RS485, sensOstep™ encoder | 28 x 28 x 62 max. |

Table 2.1 Order codes

The following options are currently available:

| Firmware option | Description | Order code example: |
|-----------------|--|---------------------|
| -TMCL | Module pre-programmed with TMCL firmware | PD28-1-1021-TMCL |

Table 2.2 PD28-1-1021 / PD28-3-1021 firmware options

A cable loom set is available for this module:

| Order code | Description |
|-----------------|--|
| TMCM-1021-CABLE | Cable loom for TMCM-1021 <ul style="list-style-type: none"> - 1x cable loom for power, communication and I/O connector (cable length approx. 200mm) - 1x cable loom for motor connector (cable length ca. 200mm) |

Table 2.5 Cable loom order code

3 Mechanical and Electrical Interfacing

The PD28-1-1021 consists of the NEMA11 / 28mm flange size stepper motor QSH2818-32-07-006 with controller / driver electronics TCMC-1021 mounted on its backside and integrated sensOstep™ encoder. The PD28-3-1021 uses the longer QSH2818-51-07-012 NEMA11 / 28mm stepper motor together with the same electronics and encoder.

Please see also stepper motor manuals and TCMC-1021 hardware and firmware manuals for more details.

Note:

In order to make proper use of the integrated sensOstep™ encoder (the sensor IC is placed on the bottom of the pcb) the TCMC-1021 electronics should not be removed/moved relative to the motor.

In case the integrated encoder feature is not used, the electronics may be moved or even removed from the motor and placed somewhere else according to application requirements.

3.1.1 Dimensions of PD28-1-1021

The PD28-1-1021 consists of the stepper motor QSH2818-32-07-006, the TCMC-1021 controller / driver electronics and integrated sensOstep™ encoder.

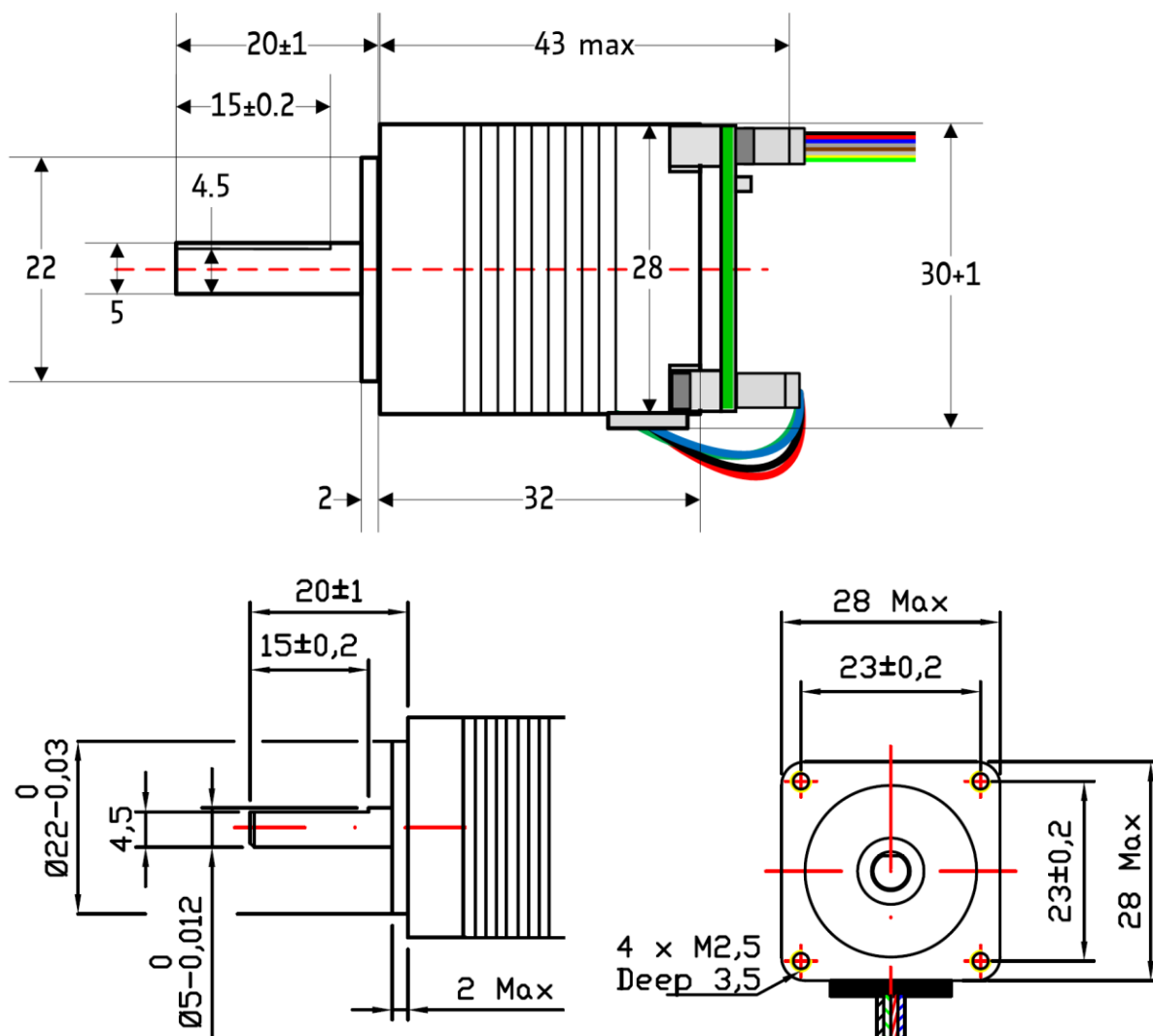

Figure 3.1 PD28-1-1021 dimensions (all dimensions in mm)

3.1.2 Dimensions of PD28-3-1021

The PD28-3-1021 consists of the stepper motor QSH2818-51-07-012, the TCMCM-1021 controller / driver electronics and integrated sensOstep™ encoder.

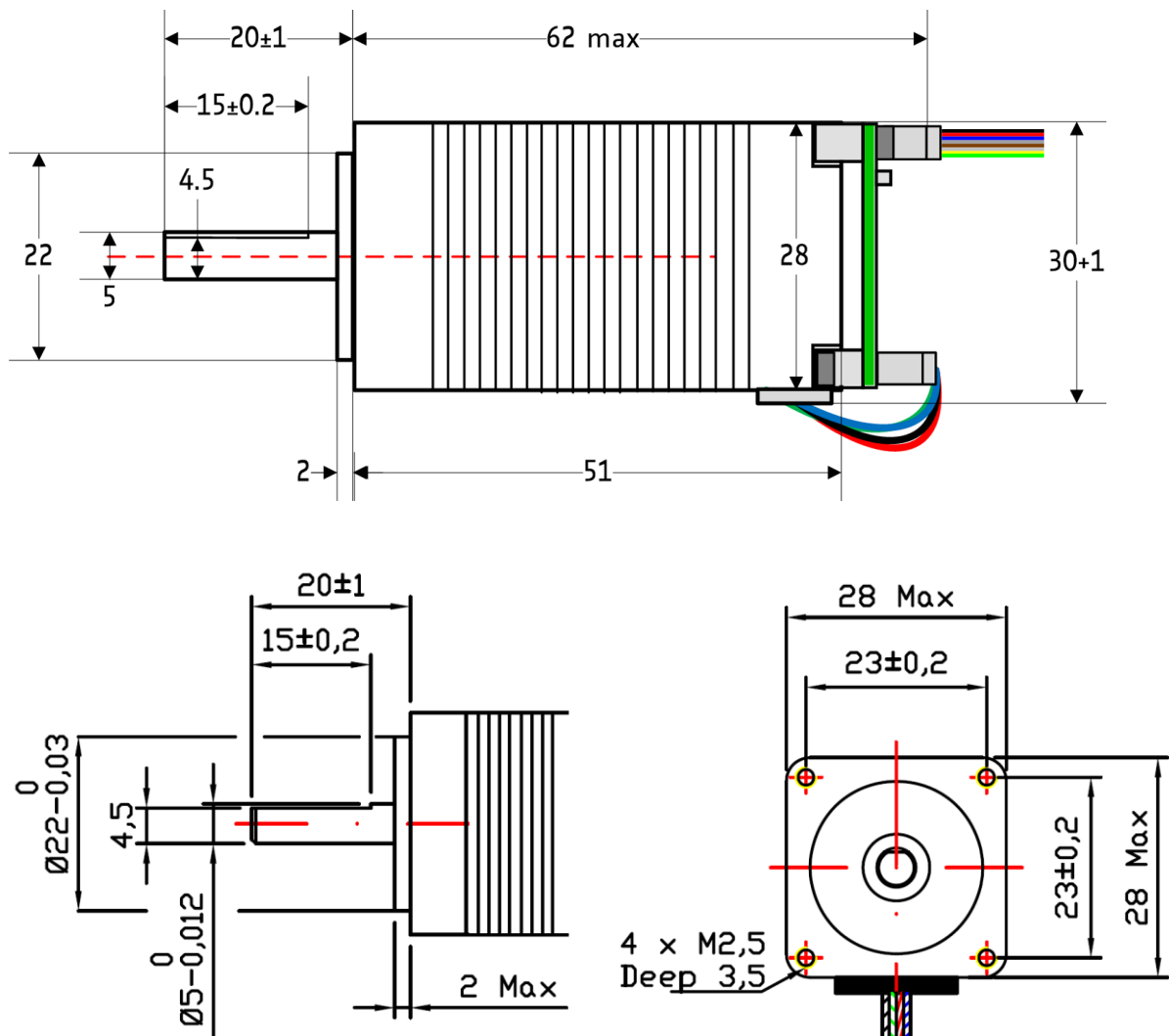

Figure 3.2 PD28-3-1021 dimensions (all dimensions in mm)

3.2 Motor Characteristics

Main characteristics of the two different motors available as part of the PD28-1-1021 (QSH2818-32-07-006) and PD28-3-1021 (QSH2818-51-07-012):



| Specification | Parameter | Units | QSH2818-32-07-006 | QSH2818-51-07-012 |
|--|------------------|-------------------|-------------------|-------------------|
| Related PANdrive | | | PD28-1-1021 | PD28-3-1021 |
| Rated Voltage | V_{RATED} | V | 3.8 | 6.2 |
| Rated Phase Current | I_{RMS_RATED} | A | 0.67 | 0.67 |
| Phase Resistance at 20°C | R_{COIL} | Ω | 5.6 | 9.2 |
| Phase Inductance (typ.) | | mH | 3.4 | 7.2 |
| Holding Torque (typ.) | | Ncm | 6 | 12 |
| | | oz in | 8.5 | 17.0 |
| Detent Torque | | Ncm | | |
| Rotor Inertia | | g cm ² | 9 | 18 |
| Weight (Mass) | | Kg | 0.11 | 0.2 |
| Insulation Class | | | B | B |
| Insulation Resistance | | Ω | 100M | 100M |
| Dialectic Strength (for one minute) | | VAC | 500 | 500 |
| Connection Wires | | N° | 4 | 4 |
| Step Angle | | ° | 1.8 | 1.8 |
| Step angle Accuracy (max.) | | % | 5 | 5 |
| Flange Size (max.) | | mm | 28.0 | 28.0 |
| Motor Length (max.) | L_{MAX} | mm | 32 | 51 |
| Axis Diameter | | mm | 5.0 | 5.0 |
| Axis Length (typ.) | | mm | 20.0 | 20.0 |
| Shaft Radial Play (450g load) | | mm | 0.02 | 0.02 |
| Shaft Axial Play (450g load) | | mm | 0.08 | 0.08 |
| Maximum Radial Force (20 mm from front flange) | | N | 28 | 28 |
| Maximum Axial Force | | N | 10 | 10 |
| Ambient Temperature | | °C | -20...+50 | -20...+50 |
| Temp Rise (rated current, 2phase on) | | °C | max. 80 | max. 80 |

Table 3.1 NEMA 11 / 28mm technical motor data

3.3 Integrated sensOstep™ encoder

The PD28-1-1021 and PD28-3-1021 PANdrive offer integrated sensOstep™ encoders based on hall sensor technology. As the name "sensOstep™" already indicates intended use of this type of compact and highly integrated encoder is step loss detection of motor movements. As soon as the motor has been moved to a new location the position may be verified using this encoder feedback. In case the stepper motor has lost one or multiple steps during movement e.g. due to overload / any obstacle encountered during movement the motor axes will jump for at least one electrical period / 4 full steps. This can be detected using the integrated encoder. In addition, step losses may be already detected during motor movements using the "deviation" setting available as part of the TMCL firmware (see TCM-1021 firmware manual for more details).

While the encoder offers 10bit (1024 steps) resolution per motor revolution the absolute position information is less accurate and depends on the displacement of the hall sensor based encoder IC relative to the magnet and motor axis among other factors. Every PANdrive™ has been tested for maximum deviation of +/- 5 encoder steps (static performance) relative to commanded microstep target position during final tests after assembly at our factory. This will ensure more than adequate performance of the integrated sensOstep™ encoder for step loss detection during motor movements.

| | |
|---|---|
|  | <p>Do not disassemble PANdrive™ when using integrated encoder</p> <p>In order to make proper use of the integrated sensOstep™ encoder (the sensor IC is placed on the bottom center of the pcb) the TCM-1021 electronics should not be removed/moved relative to the motor! Otherwise encoder performance might suffer / not work.</p> <p><i>Note: In case the integrated encoder feature is not used, the TCM-1021 electronics may be moved or even removed from the motor and placed somewhere else according to application requirements.</i></p> |
|  | <p>Keep the electronics free of (metal) particles!</p> <p>The integrated sensOstep™ encoder uses a magnet at the end of the motor axis in order to monitor position of the motor axis. The magnet naturally attracts especially tiny metal particles. These particles might be held on the top side of the PCB and even worse – start moving in accordance with the rotating magnetic field as soon as the motor starts moving. This might lead to shorts of electronic contacts / wires on the board and totally erratic behavior of the module! Use compressed air for cleaning the module if necessary (especially in prototype setups).</p> <p><i>In order to prevent shorts and better protect the electronics the TCM-1021 printed circuit board is coated after assembly of components since hardware version V1.4.</i></p> |

3.4 Connectors

The PD-1021 has two connectors, an 8-pin power and input/output connector and a 4-pin motor connector (used to connect the attached motor).

Power / communication / I/Os

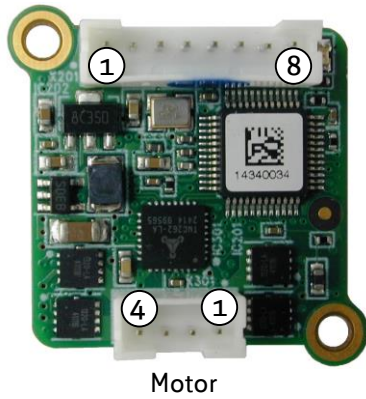

Figure 3.3 PD-1021 connectors

Overview of connector and mating connector types:

| Label | Connector type | Mating connector types |
|------------------------------|---|--|
| Power, communication and I/O | CI0108P1VK0-LF CVIlux CI01 series, 8pins, 2mm pitch | Connector housing CVIlux: CI01085000-A Contacts CVIlux: CI01T011PE0-A <i>or</i> Connector housing JST: PHR-8 Contacts JST: SPH-002T-P0.5S Wire: 0.22mm ² |
| Motor | CI0104P1VK0-LF CVIlux CI01 series, 4 pins, 2mm pitch | Connector housing CVIlux: CI01045000-A Contacts CVIlux: CI01T011PE0-A <i>or</i> Connector housing JST: PHR-4 Contacts JST: SPH-002T-P0.5S Wire: 0.22mm ² |

Table 3.2 Connectors and mating connectors, contacts and applicable wire

3.4.1 Power, Communication and I/O Connector

An 8-pin, 2mm pitch single row connector is used for power supply, RS485 serial communication and additional multi-purpose inputs and outputs.

| Pin | Label | Direction | Description |
|-----|--------------|----------------|--|
| 1 | GND | Power (GND) | GND |
| 2 | VDD | Power (Supply) | VDD, typ. +24V (+9V...+28V max.) |
| 3 | RS485+ | Bidirectional | RS485 interface, diff. signal (non-inverting) |
| 4 | RS485- | Bidirectional | RS485 interface, diff. signal (inverting) |
| 5 | IN_0 | Input | General purpose digital input, +24V compatible, internal 20k pull-down resistor |
| | | | Alternate function 1: Step input, +24V compatible, internal 20k pull-down resistor. <i>Please note: the bandwidth of the low-pass (noise rejection) filter at the input is 16kHz (-3dB) which will limit the upper step frequency</i> |
| | | | Alternate function 2: Left stop switch, +24V compatible, internal 20k pull-down resistor |
| 6 | IN_1 | Input | General purpose digital input, +24V compatible, internal 20k pull-down resistor |
| | | | Alternate function 1: Direction input, +24V compatible, internal 20k pull-down resistor <i>Please note: the bandwidth of the low-pass (noise rejection) filter at the input is 16kHz (-3dB)</i> |
| | | | Alternate function 2: Right stop switch, +24V compatible, internal 20k pull-down resistor |
| 7 | OUT_0 / IN_2 | Output / Input | Open drain output with freewheeling diode (max. 100mA) <i>Please note: there is a 20k pull-down resistor of the input connected in parallel</i> |
| | | | Alternate function 1: general purpose digital input, +24V compatible, internal 20k pull-down resistor |
| | | | Alternate function 2: home switch, +24V compatible, internal 20k pull-down resistor |
| 8 | OUT_1 / IN_3 | Output / Input | Open drain output with freewheeling diode (max. 100mA) <i>Please note: there is a 20k pull-down resistor of the input connected in parallel</i> |
| | | | Alternate function 1: digital input, +24V compatible, internal 20k pull-down resistor |
| | | | Alternate function 2: analog input, 0..6.6V range, +24V survival, internal 20k pull-down resistor |



Table 3.2 8pin power, communication and I/O connector

3.4.1.1 Power supply

For proper operation care has to be taken with regard to power supply concept and design. Due to space restrictions the PD28-1-1021 / PD28-3-1021 includes just about 20µF/35V (TMCM-1021 V1.2) resp. 30µF/35V (TMCM-1021 V1.4) of supply filter capacitors. These are ceramic capacitors which have been selected for high reliability and long life time. The module includes a 24V suppressor diode for over-voltage protection.

Please take the following measures into account in order to avoid serious damage of the device:

| | |
|---|--|
|  | <p>Add external power supply capacitors!</p> <p>It is recommended to connect an electrolytic capacitor of significant size (e.g. 470µF/35V) to the power supply lines next to the PD28-1-1021 / PD28-3-1021!</p> <p>Rule of thumb for size of electrolytic capacitor: $c = 1000 \frac{\mu\text{F}}{\text{A}} \times I_{\text{SUPPLY}}$</p> |
|---|--|

| | |
|---|--|
| | <p>In addition to power stabilization (buffer) and filtering this added capacitor will also reduce any voltage spikes which might otherwise occur from a combination of high inductance power supply wires and the ceramic capacitors. In addition it will limit slew-rate of power supply voltage at the module. The low ESR of ceramic-only filter capacitors may cause stability problems with some switching power supplies.</p> |
|  | <p>Keep the power supply voltage below the upper limit of 28V! Otherwise the driver electronics will seriously be damaged! Especially, when the selected operating voltage is near the upper limit a regulated power supply is highly recommended. Please see also chapter7, operating values.</p> |
|  | <p>There is no reverse polarity protection! The module will short any reversed supply voltage due to internal diodes of the driver transistors.</p> |

3.4.1.2 RS485

For remote control and communication with a host system the PD28-1-1021 / PD28-3-1021 provides a two wire RS485 bus interface. For proper operation the following items should be taken into account when setting up an RS485 network:

1. **BUS STRUCTURE:**

The network topology should follow a bus structure as closely as possible. That is, the connection between each node and the bus itself should be as short as possible. Basically, it should be short compared to the length of the bus.

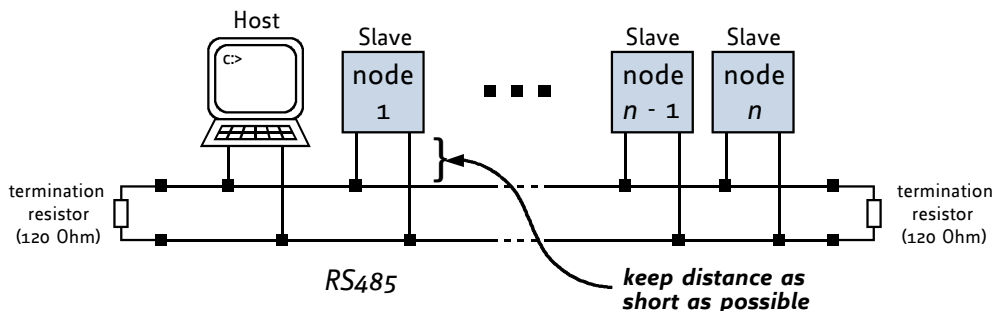

Figure 3.4: Bus structure

2. **BUS TERMINATION:**

Especially for longer busses and/or multiple nodes connected to the bus and/or high communication speeds, the bus should be properly terminated at both ends. The PD28-1-1021 / PD28-3-1021 does not integrate any termination resistor. Therefore, 120 Ohm termination resistors at both ends of the bus have to be added externally.

3. **NUMBER OF NODES:**

The RS485 electrical interface standard (EIA-485) allows up to 32 nodes to be connected to a single bus. The bus transceivers used on the PD28-1-1021 / PD28-3-1021 units (TMC-1021 hardware V1.2: SN65HVD3082ED, since hardware V1.4: SN65HVD1781D) have a significantly reduced bus load and allow a maximum of 255 units to be connected to a single RS485 bus using TMCL firmware. *Please note: usually it cannot be expected to get reliable communication with the maximum number of nodes connected to one bus and maximum supported communication speed at the same time. Instead, a compromise has to be found between bus cable length, communication speed and number of nodes.*

4. **COMMUNICATION SPEED:**

The maximum RS485 communication speed supported by the PD28-1-1021 / PD28-3-1021 is 115200 bit/s (FW version 1.29 with TCMC-1021 hardware version 1.2 and 1.4). Factory default is 9600 bit/s. Please see separate TCMC-1021 TMCL firmware manual for information regarding other possible communication speeds below 115200 bit/s.

5. **NO FLOATING BUS LINES:**

Avoid floating bus lines while neither the host/master nor one of the slaves along the bus line is transmitting data (all bus nodes switched to receive mode). Floating bus lines may lead to communication errors. In order to ensure valid signals on the bus it is recommended to use a resistor network connecting both bus lines to well defined logic levels.

There are actually two options which can be recommended:

Add resistor (Bias) network on **one** side of the bus, only (120R termination resistor still at **both** ends):

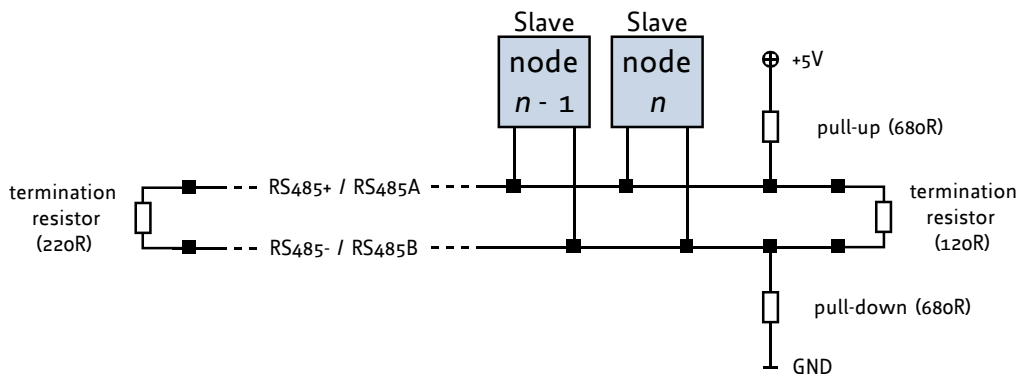

Figure 3.5: Bus lines with resistor (Bias) network on one side, only

Or add resistor (Bias) network at **both** ends of the bus (like Profibus™ termination):

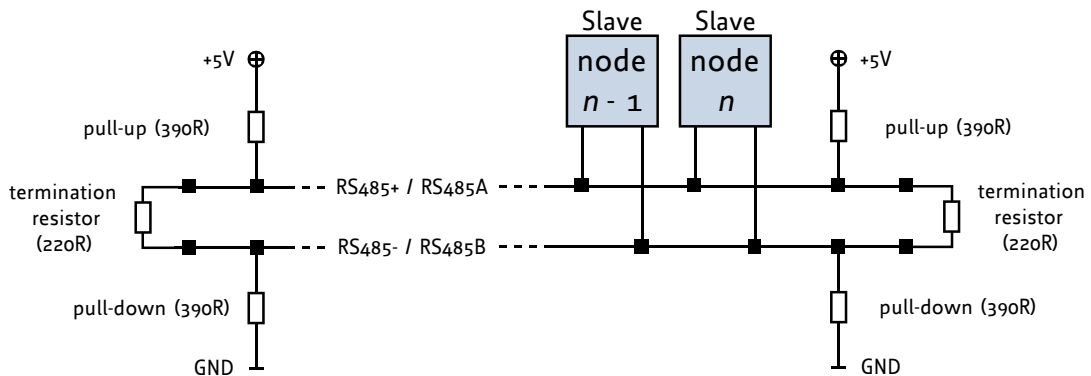

Figure 3.6: Bus lines with resistor (Bias) network at both ends

Certain RS485 interface converters available for PCs already include these additional resistors (e.g. USB-2-485 with bias network at one end of the bus).

3.4.1.3 Digital Inputs IN_0 and IN_1

The eight pin connector of the PD28-1-1021 / PD28-3-1021 provides four general purpose inputs IN_0, IN_1, IN_2 and IN_3. The first two inputs have dedicated connector pins while the other two share pins with two general purpose outputs.

All four inputs are protected using voltage resistor dividers together with limiting diodes against voltages below 0V (GND) and above +3.3V DC. Input circuit of the first two inputs IN_0 and IN_1 is shown below:

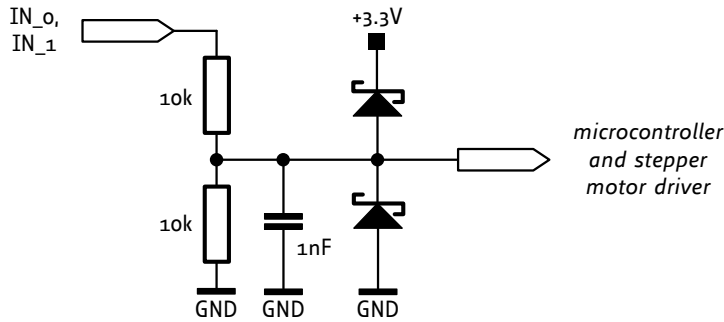

Figure 3.7 General purpose inputs IN_0 and IN_1

The two inputs have alternate functions depending on configuration in software. The following functions are available:

| Label (connector pin) | Default Function | Alternate function 1 | Alternate function 2 |
|-----------------------|--|---|--|
| IN_0 (5) | Digital input <i>+24V compatible, internal 20k pull-down resistor</i> | Step signal input (connected to stepper motor driver step input) <i>+24V compatible, internal 20k pull-down resistor.</i> <i>Please note: the bandwidth of the low-pass RC (10k / 1nF) filter at the input is 16kHz (-3dB) which will limit the upper step frequency</i> | Left stop switch <i>+24V compatible, internal 20k pull-down resistor</i> |
| IN_1 (6) | Digital input <i>+24V compatible, internal 20k pull-down resistor</i> | Direction signal input (connected to stepper motor driver direction input) <i>+24V compatible, internal 20k pull-down resistor.</i> <i>Please note: the bandwidth of the low-pass RC (10k / 1nF) filter at the input is 16kHz (-3dB)</i> | Right stop switch <i>+24V compatible, internal 20k pull-down resistor</i> |

Table 3.3 Multipurpose inputs / alternate functions

All four inputs are connected to the on-board processor and can be used as general purpose digital inputs.

Using the alternate function 1 of IN_0 and IN_1 it is possible to control the on-board stepper motor driver with the help of an external stepper motor controller using step and direction signals (Please see separate TMCL firmware manual / axis parameter 254 for more details how to enable this mode). For the step and direction signals the signal levels are the same as for the general purpose digital inputs. Please note that the low-pass filter (for noise rejection) at the inputs offers a bandwidth of 16kHz (-3dB).

IN_3 can be used as analog input, also. A 12bit analog to digital converter integrated in the microcontroller will convert any analog input voltage between 0 and +6.6V to a digital value between 0 and 4095 then.

3.4.1.4 Inputs IN_2, IN_3, Digital Outputs OUT_0, OUT_1

The eight pin connector of the PD28-1-1021 / PD28-3-1021 provides two general purpose outputs. These two outputs are open-drain outputs and can sink up to 100mA each. Both outputs OUT_0 and OUT_1 share pins with two of the four inputs (IN_2 resp. IN_3).

The inputs are protected using voltage resistor dividers together with limiting diodes against voltages below 0V (GND) and above +3.3V DC. The circuit of the two outputs and the two inputs connected in parallel to the inputs is shown below:

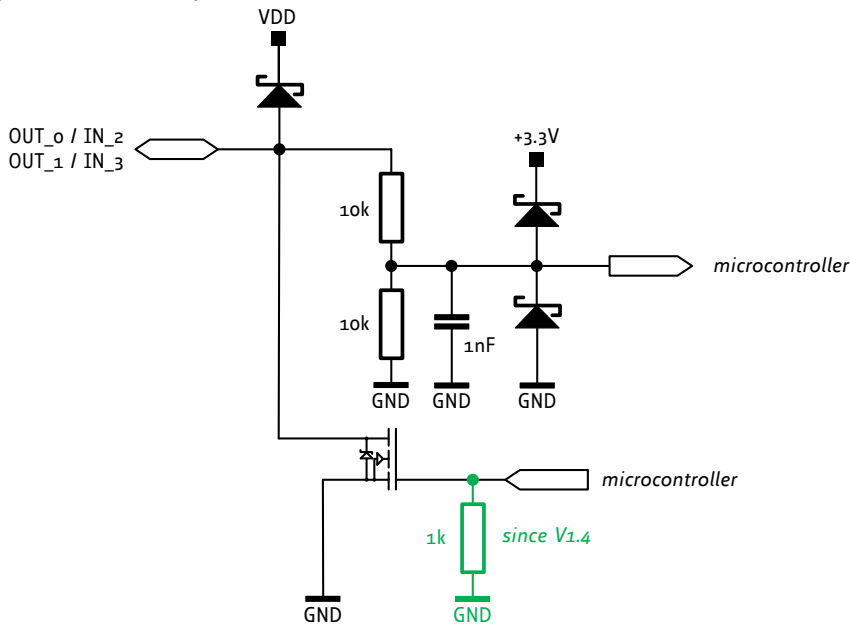

Figure 3.8 General purpose outputs OUT_0, OUT_1 and inputs IN_2, IN_3 connected in parallel

The outputs of the N-channel MOSFET transistors (Open-Drain) are connected to freewheeling diodes each for protection against voltage spikes especially from inductive loads (relais etc.). Please take into account the 20k (2x 10k in series) resistance to ground (transistor not active) of the input voltage divider (figure 4.8) when designing the external "load" circuit.

Since hardware version 1.4 the gate inputs of the MOSFETs are pulled-low during power-up and while the processor might be still in reset / output pins not initialized. This way, the outputs will not briefly switch on at power-up.

The two outputs OUT_0 / OUT_1 and inputs IN_2 / IN_3 have alternate functions depending on configuration in software:

| Label (connector pin) | Default Function | Alternate function 1 | Alternate function 2 |
|-----------------------|--|---|---|
| OUT_0 / IN_2 (7) | Open drain output with freewheeling diode (max. 100mA) <i>Please note: there is a 20k pull-down resistor of the input connected in parallel</i> | Alternate function 1: general purpose digital input, +24V compatible, internal 20k pull-down resistor | Alternate function 2: home switch, +24V compatible, internal 20k pull-down resistor |
| OUT_1 / IN_3 (8) | Open drain output with freewheeling diode (max. 100mA) <i>Please note: there is a 20k pull-down resistor of the input connected in parallel</i> | Alternate function 1: digital input, +24V compatible, internal 20k pull-down resistor | Alternate function 2: analog input, 0..6.6V range, +24V survival, internal 20k pull-down resistor |

Table 3.4 Multipurpose outputs / inputs / alternate functions

Do not apply any voltage above supply voltage to inputs IN_2 and IN_3. Due to the freewheeling diodes of the outputs connected in parallel they will be shorted to power supply input voltage.



| | |
|---|---|
| | |
|  | <p>For hardware version 1.2: Do not connect either IN_2 or IN_3 directly to a low resistance supply voltage (e.g. directly to any power supply voltage). As the output transistors connected in parallel might briefly switch-on during power-up they might be damaged / destroyed if the current through the transistors to ground exceeds 100mA.</p> |

3.4.2 Motor Connector

A 4-pin, 2mm pitch single row connector is used for connecting the four motor wires to the electronics.

| Pin | Label | Direction | Description |
|-----|-------|-----------|-----------------------|
| 1 | OB2 | Output | Pin 2 of motor coil B |
| 2 | OB1 | Output | Pin 1 of motor coil B |
| 3 | OA2 | Output | Pin 2 of motor coil A |
| 4 | OA1 | Output | Pin 1 of motor coil A |

Table 3.4 Motor connector

| | |
|---|--|
|  | <p>Do not connect or disconnect motor during operation!</p> <p>Motor cable and motor inductivity might lead to voltage spikes when the motor is disconnected / connected while energized. These voltage spikes might exceed voltage limits of the driver MOSFETs and might permanently damage them. Therefore, always disconnect power supply before connecting / disconnecting the motor.</p> |
|  | <p>For TCM-1021 hardware version 1.4: please note the additional high current range for motor currents up-to 1.4A RMS!</p> <p>Setting motor current too high might lead to excessive power dissipation inside the motor, overheating and even permanent damage of the motor. Therefore, make sure the motor current is properly set. Also with hardware version 1.4 the low current range is set as default. Do not use the high current range with the PD28-1-1021 and PD28-3-1021 PANdrives for prolonged time!</p> |

| PD28-1-1021 PD28-3-1021 | QSH2818-32-07-006 QSH2818-51-07-012 | | |
|----------------------------|--|------|--------------------|
| Motor connector pin | Cable colour | Coil | Description |
| 1 | Blue | B- | Motor coil B pin 2 |
| 2 | Red | B | Motor coil B pin 1 |
| 3 | Green | A- | Motor coil A pin 2 |
| 4 | Black | A | Motor coil A pin 1 |

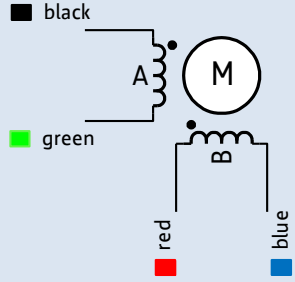

4 Motor driver current

The on-board stepper motor driver operates current controlled. The driver current may be programmed in software in two ranges (low current range up-to 0.7A RMS and high current range up-to 1.4A RMS) with 32 effective scaling steps in hardware for each range. *Please note: the high current range is available with TCMC-1021 hardware revision V1.4, only – not with hardware revision V1.2!*

| | |
|---|--|
|  | <p>Be careful when setting motor current!</p> <p>The stepper motors used for the PD28-1-1021 and PD28-3-1021 PANdrives have a rated current of 0.67A RMS. Therefore, it is not recommended to use any current setting significantly above the rated motor current – especially, not for prolonged amount of time. Usually, it is not recommended to use the high current range settings with the PD28-1-1021 and PD28-3-1021 PANdrives. Please carefully monitor motor temperature when switching to high current settings.</p> |
|---|--|

Explanation of different columns in table below:

Motor current setting in software (TMCL)

These are the values for TMCL axis parameter 6 (motor run current) and 7 (motor standby current). They are used to set the run / standby current using the following TMCL commands:

```
SAP 6, 0, <value> // set run current
```

```
SAP 7, 0, <value> // set standby current
```

(read-out value with GAP instead of SAP. Please see separate TCMC-1021 firmware manual for further information)

Range setting in software (TMCL)

This is the value for TMCL axis parameter 179 (Vsense). This value defines the current range. This value can be set using the following TMCL command:

```
SAP 179, 0, <value> // = 0 high current range
// = 1 low current range
```

For <value> either 0 (high current range) or 1 (low current range) is supported (see table) since hardware revision V1.4. For earlier hardware revisions (incl. V1.2) this parameter is set to the fixed value "1" (low current range).

(read-out value with GAP instead of SAP. Please see separate TCMC-1021 firmware manual for further information)

Motor current I_{RMS} [A]

Resulting motor current based on range and motor current setting

| Motor current setting in software (TMCL) | Range setting in software (TMCL) | Current scaling step (CS) | Motor current I_{COIL_PEAK} [A] | Motor current I_{COIL_RMS} [A] |
|--|----------------------------------|---------------------------|------------------------------------|-----------------------------------|
| 0..7 | 1 | 0 | 0.034 | 0.024 |
| 8..15 | 1 | 1 | 0.069 | 0.049 |
| 16..23 | 1 | 2 | 0.103 | 0.073 |
| 24..31 | 1 | 3 | 0.138 | 0.097 |
| 32..39 | 1 | 4 | 0.172 | 0.122 |
| 40..47 | 1 | 5 | 0.206 | 0.146 |
| 48..55 | 1 | 6 | 0.241 | 0.170 |
| 56..63 | 1 | 7 | 0.275 | 0.194 |
| 64..71 | 1 | 8 | 0.309 | 0.219 |
| 72..79 | 1 | 9 | 0.344 | 0.243 |

| Motor current setting in software (TMCL) | Range setting in software (TMCL) | Current scaling step (CS) | Motor current I_{COIL_PEAK} [A] | Motor current I_{COIL_RMS} [A] |
|--|----------------------------------|---------------------------|------------------------------------|-----------------------------------|
| 80..87 | 1 | 10 | 0.378 | 0.267 |
| 88..95 | 1 | 11 | 0.413 | 0.292 |
| 96..103 | 1 | 12 | 0.447 | 0.316 |
| 104..111 | 1 | 13 | 0.481 | 0.340 |
| 112..119 | 1 | 14 | 0.516 | 0.365 |
| 120..127 | 1 | 15 | 0.550 | 0.389 |
| 128..135 | 1 | 16 | 0.584 | 0.413 |
| 136..143 | 1 | 17 | 0.619 | 0.438 |
| 144..151 | 1 | 18 | 0.653 | 0.462 |
| 152..159 | 1 | 19 | 0.688 | 0.486 |
| 160..167 | 1 | 20 | 0.722 | 0.510 |
| 168..175 | 1 | 21 | 0.756 | 0.535 |
| 176..183 | 1 | 22 | 0.791 | 0.559 |
| 184..191 | 1 | 23 | 0.825 | 0.583 |
| 192..199 | 1 | 24 | 0.859 | 0.608 |
| 200..207 | 1 | 25 | 0.894 | 0.632 |
| 208..215 | 1 | 26 | 0.928 | 0.656 |
| 216..223 | 1 | 27 | 0.963 | 0.681 |
| 224..231 | 1 | 28 | 0.997 | 0.705 |
| 232..239 | 1 | 29 | 1.031 | 0.729 |
| 240..247 | 1 | 30 | 1.066 | 0.754 |
| 248..255 | 1 | 31 | 1.100 | 0.778 |
| 0..7 | 0 | 0 | 0.064 | 0.045 |
| 8..15 | 0 | 1 | 0.127 | 0.090 |
| 16..23 | 0 | 2 | 0.191 | 0.135 |
| 24..31 | 0 | 3 | 0.254 | 0.180 |
| 32..39 | 0 | 4 | 0.318 | 0.225 |
| 40..47 | 0 | 5 | 0.381 | 0.270 |
| 48..55 | 0 | 6 | 0.445 | 0.315 |
| 56..63 | 0 | 7 | 0.508 | 0.359 |
| 64..71 | 0 | 8 | 0.572 | 0.404 |
| 72..79 | 0 | 9 | 0.635 | 0.449 |
| 80..87 | 0 | 10 | 0.699 | 0.494 |
| 88..95 | 0 | 11 | 0.763 | 0.539 |
| 96..103 | 0 | 12 | 0.826 | 0.584 |
| 104..111 | 0 | 13 | 0.890 | 0.629 |
| 112..119 | 0 | 14 | 0.953 | 0.674 |
| 120..127 | 0 | 15 | 1.017 | 0.719 |
| 128..135 | 0 | 16 | 1.080 | 0.764 |
| 136..143 | 0 | 17 | 1.144 | 0.809 |
| 144..151 | 0 | 18 | 1.207 | 0.854 |
| 152..159 | 0 | 19 | 1.271 | 0.899 |
| 160..167 | 0 | 20 | 1.334 | 0.944 |
| 168..175 | 0 | 21 | 1.398 | 0.988 |
| 176..183 | 0 | 22 | 1.461 | 1.033 |
| 184..191 | 0 | 23 | 1.525 | 1.078 |
| 192..199 | 0 | 24 | 1.589 | 1.123 |
| 200..207 | 0 | 25 | 1.652 | 1.168 |
| 208..215 | 0 | 26 | 1.716 | 1.213 |
| 216..223 | 0 | 27 | 1.779 | 1.258 |
| 224..231 | 0 | 28 | 1.843 | 1.303 |
| 232..239 | 0 | 29 | 1.906 | 1.348 |
| 240..247 | 0 | 30 | 1.970 | 1.393 |

| Motor current setting in software (TMCL) | Range setting in software (TMCL) | Current scaling step (CS) | Motor current $I_{\text{COIL_PEAK}}$ [A] | Motor current $I_{\text{COIL_RMS}}$ [A] |
|--|----------------------------------|---------------------------|---|--|
| 248..255 | 0 | 31 | 2.033 | 1.438 |

Please note: these settings clearly exceed motor current rating for the PD28-1-1021 and PD28-3-1021 configurations!

In addition to the settings in the table the motor current may be switched off completely (free-wheeling) using axis parameter 204 (see TCM-1021 firmware manual).

5 Reset to Factory Defaults

It is possible to reset the PD28-1-1021 / PD28-3-1021 to factory default settings without establishing a communication link. This might be helpful in case communication parameters of the preferred interface have been set to unknown values or got accidentally lost.

For this procedure it is necessary to disassemble the PANdrive and shorten two pads on the bottom side of the printed circuit board (see Figure 5.1).

Please perform the following steps:

1. Power supply off
2. Short two pads as marked in Figure 5.1
3. Power up board
4. Wait until the on-board red and green LEDs start flashing fast (this might take a while)
5. Power-off board
6. Remove short between pads
7. After switching on power-supply all permanent settings have been restored to factory defaults

Short these two PADs on
the bottom of the PCB

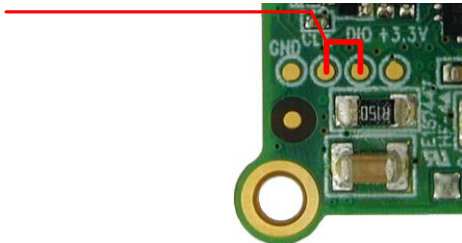

Figure 5.1 Reset to factory default settings

6 On-board LED

The board offers one LED in order to indicate board status. The function of the LED is dependent on the firmware version. With standard TMCL firmware the green LED flashes slowly during operation.

When there is no valid firmware programmed into the board or during firmware update the green LED is permanently on.

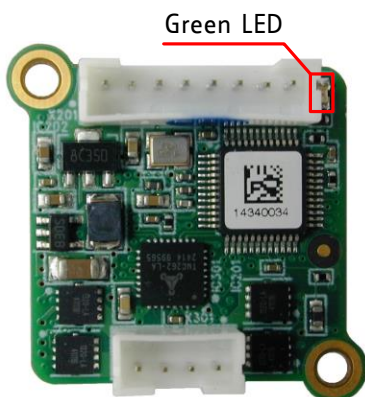

Figure 6.1 On-board LED

7 Operational Ratings

The operational ratings show the intended or the characteristic ranges and should be used as design values.

In no case shall the maximum values be exceeded!

| Symbol | Parameter | Min | Typ | Max | Unit |
|-----------------------------|--|-----|----------------------|-------------------------|------|
| VDD | Power supply voltage for operation | 9 | 12... 24 | 28 | V |
| I _{COIL_PEAK_L} | Motor coil current for sine wave peak (low range setting, chopper regulated, adjustable via software) | 0 | | 1 | A |
| I _{COIL_RMS_L} | Continuous motor current (RMS) (low current range setting, chopper regulated, adjustable via software) | 0 | | 0.7 | A |
| I _{COIL_PEAK_H} *) | Motor coil current for sine wave peak (high current range setting, chopper regulated, adjustable via software) | 0 | | 2*) | A |
| I _{COIL_RMS_H} *) | Continuous motor current (RMS) (high current range setting, chopper regulated, adjustable via software) | 0 | | 1.4*) | A |
| I _{DD} | Power supply current | | << I _{COIL} | 1.4 * I _{COIL} | A |
| T _{ENV} | Environment temperature at rated current (no forced cooling required) | -35 | | +60 | °C |

Table 7.1 General operational ratings of module

*) High current range available as new additional range with TCM-1021 hardware revision V1.4 – **not** with hardware revision V1.2. High current range settings not recommended for PANdrives PD28-1-1021 and PD28-3-1021 as the higher current settings will significantly exceed rated motor current of 0.67A RMS.

| Symbol | Parameter | Min | Typ | Max | Unit |
|-----------------------------------|---|-----|-----|------|------|
| V _{OUT_0/1} | Voltage at open collector output | 0 | | +VDD | V |
| I _{OUT_0/1} | Output sink current | | | 100 | mA |
| V _{IN_digital 0/1/2/3} | Input voltage for IN_0, IN_1, IN_2, IN_3 when used as digital input | 0 | | +VDD | V |
| V _{IN_digital_L 0/1/2/3} | Low level voltage for GPIO and GPI1 when used as digital input | 0 | | 1.2 | V |
| V _{IN_digital_H 0/1/2/3} | High level voltage for GPIO and GPI1 when used as digital input | 4 | | +VDD | V |
| V _{IN_analog 3} | Measurement range for IN_3 when used as analogue input | 0 | | +6.6 | V |

Table 7.2 Operational ratings of multipurpose I/Os

| Symbol | Parameter | Min | Typ | Max | Unit |
|-------------|---|-----|------|--------|-------|
| N_{RS485} | Number of nodes connected to single RS485 network | | | 255 | |
| f_{RS485} | Maximum bit rate supported on RS485 connection | | 9600 | 115200 | bit/s |

Table 7.3 Operational ratings of RS485 interface

8 Torque Curves

The following figures show the curve of each PANdrive.

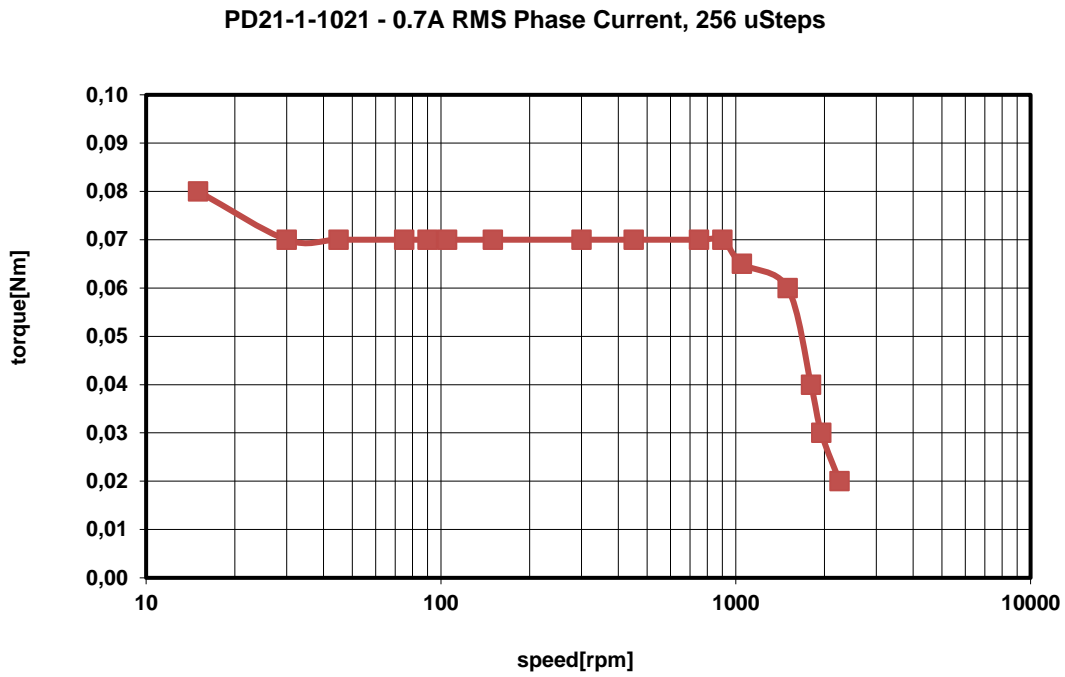

Figure 8.1 PD28-1-1021 torque vs. speed 24V / 0.7 A, 256 μ steps

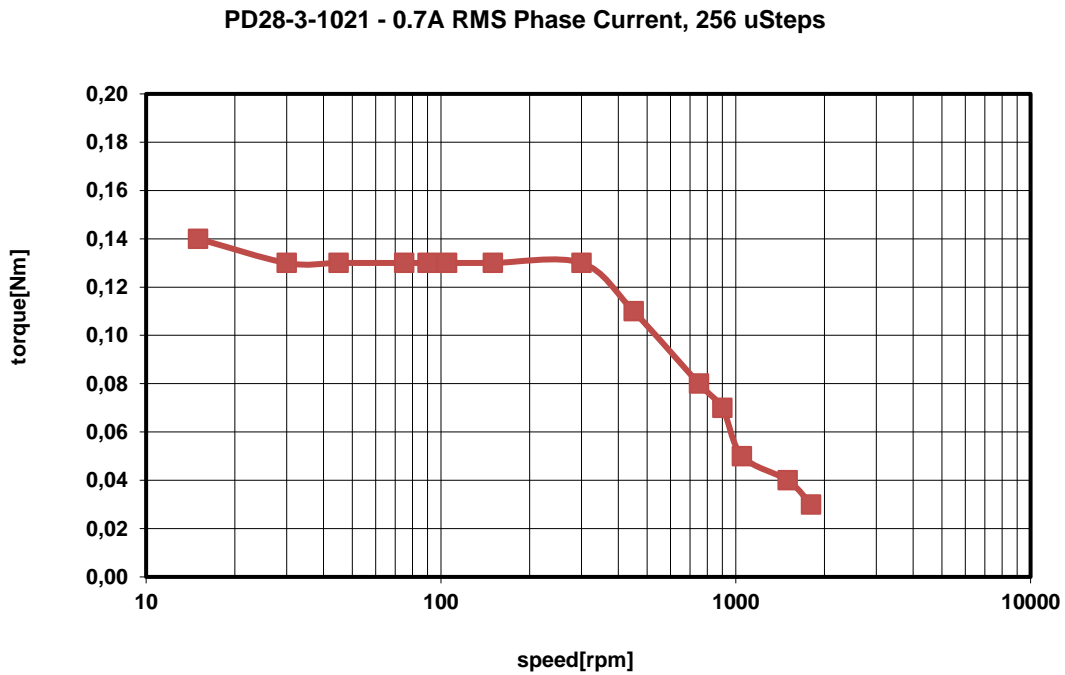

Figure 8.2 PD28-3-1021 torque vs. velocity 24V / 0.7 A, 256 μ steps

9 Functional description

The PD28-1-1021 and PD28-3-1021 are highly integrated mechatronic devices which can be controlled via RS485 serial interface. Communication traffic is kept low since all time critical operations, e.g. ramp calculations are performed on board. Nominal supply voltage of the unit is 24V DC. The PANdrive is designed for both: direct mode and standalone operation. Full remote control of device with feedback is possible. The firmware of the module can be updated via the serial interface.

In Figure 9.1 the main parts of the PD28-1-1021 and PD28-3-1021 are shown:

- microcontroller, which runs the TMCL script language interpreter (connected to TMCL memory),
- power driver with stallGuard2™ and its energy efficient coolStep™ feature,
- MOSFET driver stage,
- QSH2818-32-07-006 or QSH2818-51-07-012 bipolar hybrid stepper motor
- sensOstep™ encoder with resolutions of 10bit (1024 steps) per revolution.

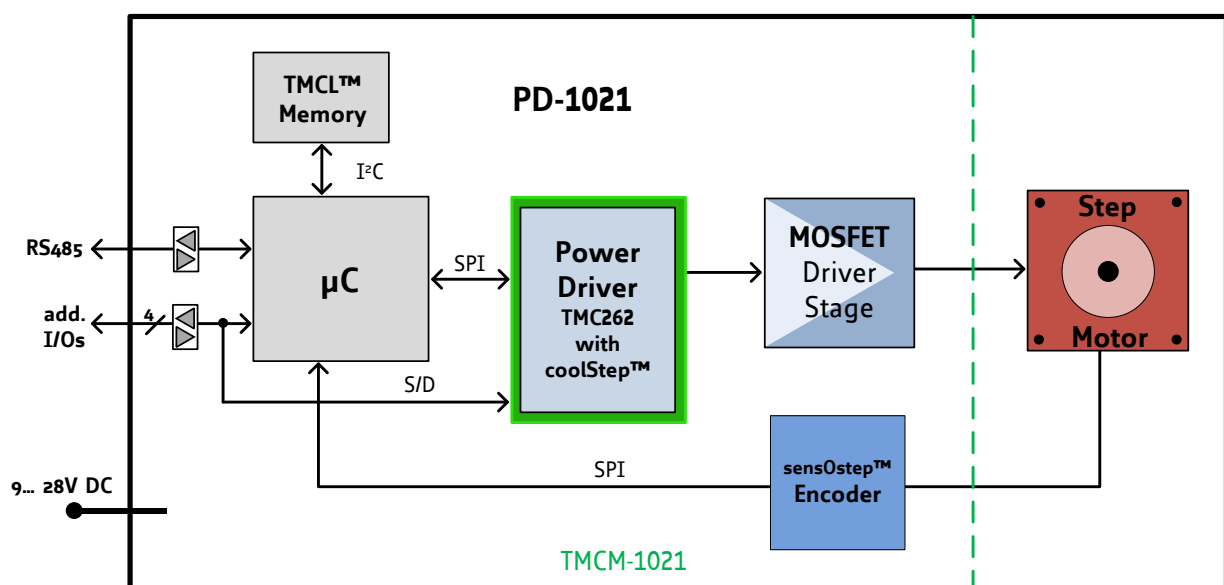

Figure 9.1: Main parts of PD28-1-1021 and PD28-3-1021

The PD28-1-1021 / PD28-3-1021 comes with the PC based software development environment TMCL-IDE for the Trinamic Motion Control Language (TMCL). Using predefined TMCL high level commands like *move to position* a rapid and fast development of motion control applications is guaranteed.

Please refer to the PD28-1-1021 / PD28-3-1021 Firmware Manual for more information about TMCL commands.

10 Life Support Policy

TRINAMIC Motion Control GmbH & Co. KG does not authorize or warrant any of its products for use in life support systems, without the specific written consent of TRINAMIC Motion Control GmbH & Co. KG.

Life support systems are equipment intended to support or sustain life, and whose failure to perform, when properly used in accordance with instructions provided, can be reasonably expected to result in personal injury or death.

© TRINAMIC Motion Control GmbH & Co. KG 2013 – 2018

Information given in this data sheet is believed to be accurate and reliable. However neither responsibility is assumed for the consequences of its use nor for any infringement of patents or other rights of third parties, which may result from its use.

Specifications are subject to change without notice.

All trademarks used are property of their respective owners.



11 Revision History

11.1 Document Revision

| Version | Date | Author | Description |
|---------|-------------|--------|--|
| 0.90 | 2011-AUG-02 | GE | Initial version |
| 0.91 | 2011-AUG-25 | SD | Information about left, right, and home switch added. Minor changes |
| 0.92 | 2011-NOV-10 | GE | <ul style="list-style-type: none"> - Motor connector corrected and motor connection added - General purpose output circuit extended - Hardware revision list updated |
| 1.00 | 2012-JUN-20 | SD | <ul style="list-style-type: none"> - Rule of thumb for capacitor added. - Design updated - Chapter 6 (on-board LED) new - Chapter 5 (reset to factory defaults) new - Torque curves added |
| 1.01 | 2013-JUL-23 | SD | <ul style="list-style-type: none"> - Connector types updated. - Chapter Fehler! Verweisquelle konnte nicht gefunden werden. updated. |
| 1.02 | 2018-JAN-23 | GE | <ul style="list-style-type: none"> - Major update. Integration of updated and new chapters from TCM-1021 hardware manual - Note on sensOstep™ encoder accuracy added |
| 1.03 | 2018-JAN-25 | GE | <ul style="list-style-type: none"> - More Details + tolerances added to motor shaft drawing |

Figure 11.1: Document revision

11.2 Hardware Revision

Please note: all current PD28-1-1021 and PD28-3-1021 PANdrives use controller driver electronics TCM-1021 V1.4. Previous versions used TCM-1021 V1.2. All other TCM-1021 hardware versions listed below have been used for prototypes, only. The following list includes changes in hardware for the TCM-1021 controller / driver electronics since initial hardware (prototype) version V1.0:

| Version | Date | Description / Modifications compared to previous versions |
|-----------------|-------------|--|
| TCM-1021_V10*) | 2011-JUL-11 | Initial version |
| TCM-1021_V11*) | 2011-AUG-18 | <ul style="list-style-type: none"> - TMC262 clock generation switched to internal clock - Encoder circuit corrected - LED added |
| TCM-1021_V12**) | 2011-SEP-28 | <ul style="list-style-type: none"> - LED moved to location near 8pin connector (version 1.2 is 100% firmware compatible with V1.1) |
| TCM-1021_V13*) | 2013-MAY-14 | <ul style="list-style-type: none"> - MOSFETs: The new driver stage is more powerful (less heat dissipation) than the one used on V1.2. The module now supports two motor current ranges (up-to 0.7A RMS (same as V1.2 – fully compatible also with respect to current scaling) and up-to 1.4A RMS motor current (new with version 1.4)). Switching between these two ranges can be done in software (lower current range: SAP 179, 0, 1 (default), higher current range: SAP 179, 0, 0). The lower current range (up-to 0.7A RMS / SAP 179, 0, 1) is the default one in order to maintain 100% compatibility in terms of motor current settings. For the lower current range the motor current can be scaled down using TMCL command SAP 6, 0, 0 ... 255 as known from the current version. Same settings will result in same motor current values as with current version. After switching to the higher current range (SAP 179, 0, 0) similar scaling is possible with the high current range, also. Due to the |

| Version | Date | Description / Modifications compared to previous versions |
|---------------|-------------|--|
| | | <p>extended current settings the module supports NEMA11 (28mm) bipolar stepper motors using the lower current range and also NEMA17 (42mm) bipolar stepper motors using the higher current range – making it possible to use just one module type in a mixed NEMA11 / NEMA17 system environment (if desired / applicable).</p> <ul style="list-style-type: none"> - RS485 transceiver: the RS485 transceiver has been replaced with the SN65HVD1781 transceiver offering better fault protection (up to 70V fault protection) and supporting more nodes in one network (up-to 255 nodes per network with TMCL firmware). The supply voltage of the transceiver IC has been reduced to +3.3V (supported by the transceiver IC) in order to reduce power consumption. - General purpose outputs OUT0 / OUT1: the driver circuit of the open-drain output MOSFETs has been modified in order to ensure glitch-free power-up. That is, output MOSFETs will not turn briefly on while processor still in reset / not initialized. - Processor speed: the processor crystal has been changed to 16MHz |
| TMCM-1021_V14 | 2013-JUL-30 | <ul style="list-style-type: none"> - On-board voltage regulator design has been improved in order to allow processor core frequencies of 32MHz (previously 16MHz and 8MHz depending on firmware version) |

*) V10, V11 and V13: prototypes only.

**) V12: series product version. Is replaced with V14 series product version due to EOL (end-of-life) of the driver MOSFETs. Please see "PCN_1012_10_22_TMCM-1021.pdf" on our Web-site, also

Figure 11.2: Hardware revision

12 References

| | |
|---------------------|---|
| [PD-1021] | PD-1021 TMCL firmware manual |
| [QSH2818-32-07-006] | NEMA11 / 28mm bipolar stepper motor used with PD28-1-1021 |
| [QSH2818-51-07-012] | NEMA11 / 28mm bipolar stepper motor used in PD28-3-1021 |
| [JST] | JST PH connector (2.0mm pitch, disconnectable crimp style) http://www.jst.com |
| [USB-2-485] | USB-2-485 interface converter manual |
| [TMC262] | TMC262 datasheet |

TRINAMIC manuals are available on <http://www.trinamic.com>.

X-ON Electronics

Largest Supplier of Electrical and Electronic Components

Click to view similar products for [Power Management IC Development Tools](#) category:

Click to view products by [Analog Devices](#) manufacturer:

Other Similar products are found below :

[EVB-EP5348UI](#) [MIC23451-AAAYFL EV](#) [MIC5281YMME EV](#) [124352-HMC860LP3E](#) [DA9063-EVAL](#) [ADP122-3.3-EVALZ](#) [ADP130-0.8-EVALZ](#) [ADP130-1.8-EVALZ](#) [ADP1740-1.5-EVALZ](#) [ADP1870-0.3-EVALZ](#) [ADP1874-0.3-EVALZ](#) [ADP199CB-EVALZ](#) [ADP2102-1.25-EVALZ](#) [ADP2102-1.875EVALZ](#) [ADP2102-1.8-EVALZ](#) [ADP2102-2-EVALZ](#) [ADP2102-3-EVALZ](#) [ADP2102-4-EVALZ](#) [AS3606-DB](#) [BQ25010EVM](#) [BQ3055EVM](#) [ISLUSBI2CKIT1Z](#) [LP38512TS-1.8EV](#) [EVAL-ADM1186-1MBZ](#) [EVAL-ADM1186-2MBZ](#) [ADP122UJZ-REDYKIT](#) [ADP166Z-REDYKIT](#) [ADP170-1.8-EVALZ](#) [ADP171-EVALZ](#) [ADP1853-EVALZ](#) [ADP1873-0.3-EVALZ](#) [ADP198CP-EVALZ](#) [ADP2102-1.0-EVALZ](#) [ADP2102-1-EVALZ](#) [ADP2107-1.8-EVALZ](#) [ADP5020CP-EVALZ](#) [CC-ACC-DBMX-51](#) [ATPL230A-EK](#) [MIC23250-S4YMT EV](#) [MIC26603YJL EV](#) [MIC33050-SYHL EV](#) [TPS60100EVM-131](#) [TPS65010EVM-230](#) [TPS71933-28EVM-213](#) [TPS72728YFFEVM-407](#) [TPS79318YEQEVM](#) [UCC28810EVM-002](#) [XILINXPWR-083](#) [LMR22007YMINI-EVM](#) [LP38501ATJ-EV](#)