

Hardware Version V1.1

# HARDWARE MANUAL

+

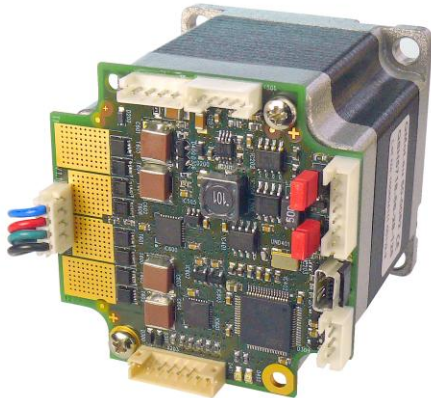

+

+

## PD-1160

Stepper Motor with  
Controller / Driver  
0.55 - 3.1 Nm / 48 V  
sens0step™ Encoder  
USB, RS485, and CAN  
Step/Dir Interface

+

### UNIQUE FEATURES

**coolStep™****stallGuard<sup>2</sup>**

TRINAMIC Motion Control GmbH & Co. KG  
Hamburg, Germany

[www.trinamic.com](http://www.trinamic.com)



**TRINAMIC**  
MOTION CONTROL

# Table of Contents

1	Features.....	3
2	Order Codes .....	5
3	Mechanical and Electrical Interfacing.....	6
3.1	PD57-1160 and PD60-1160 Dimensions.....	6
3.1.1	PD57-1160 Dimensions .....	6
3.1.2	PD60-1160 Dimensions .....	7
3.2	Connectors of PD-1160.....	8
3.2.1	Power Connector.....	9
3.2.1.1	Power Supply .....	9
3.2.2	Serial Communication Connector.....	10
3.2.2.1	RS485 .....	11
3.2.2.2	CAN.....	12
3.2.3	Multipurpose I/O Connector.....	13
3.2.3.1	Digital Inputs STOP_L, STOP_R, and HOME.....	13
3.2.3.2	General Purpose Inputs IN_0 and IN_1.....	14
3.2.3.3	Outputs OUT_0, OUT_1.....	14
3.2.4	Step/Direction Connector.....	15
3.2.4.1	Step / Direction / Enable Inputs.....	15
3.2.5	Encoder Connector.....	16
3.2.5.1	Encoder Inputs.....	16
3.2.6	Motor Connector.....	17
3.2.7	Mini-USB Connector.....	18
4	Jumpers.....	19
4.1	RS485 Bus Termination.....	19
4.2	CAN Bus Termination .....	19
5	Reset to Factory Defaults.....	20
6	On-board LEDs.....	21
7	Operational Ratings.....	22
8	Torque Curves .....	24
8.1	Curves of PD57-1160.....	24
8.1.1	PD57-1-1160 Torque Curves.....	24
8.1.2	PD57-2-1160 Torque Curves.....	26
8.2	Curves of PD60-1160.....	28
8.2.1	PD60-3-1160 Torque Curves.....	28
8.2.2	PD60-4-1160 Torque Curves.....	29
9	Functional Description.....	30
10	PD-1160 Operational Description.....	31
10.1	Calculation: Velocity and Acceleration vs. Microstep and Fullstep Frequency.....	31
11	Life Support Policy.....	33
12	Revision History.....	34
12.1	Document Revision.....	34
12.2	Hardware Revision .....	34
13	References .....	34

# 1 Features

The PANdrive™ PD-1160 is a full mechatronic solution with state of the art feature set. It is highly integrated and offers a convenient handling. The PD-1160 includes a stepper motor, controller/driver electronics, and TRINAMICs sensOstep™ encoder. It can be used in many decentralized applications and has been designed for 0.55... 3.1Nm max. holding torque and 24 or 48 V DC nominal supply voltage. With its high energy efficiency from TRINAMIC's coolStep technology cost for power consumption is kept down. The TMCL™ firmware allows for standalone operation and direct mode.

## MAIN CHARACTERISTICS

### Motion controller

- Motion profile calculation in real-time
- On the fly alteration of motor parameters (e.g. position, velocity, acceleration)
- High performance microcontroller for overall system control and serial communication protocol handling

### Bipolar stepper motor driver

- Up to 256 microsteps per full step
- High-efficient operation, low power dissipation
- Dynamic current control
- Integrated protection
- stallGuard2 feature for stall detection
- coolStep feature for reduced power consumption and heat dissipation

### Encoder

- sensOstep magnetic encoder (1024 increments per rotation) e.g. for step-loss detection under all operating conditions and positioning supervision
- Interface for connection of external incremental a/b/n encoder

### Interfaces

- RS485 interface
- CAN (2.0B up to 1Mbit/s) interface
- USB full speed (12Mbit/s) interface
- Step/Direction interface (optically isolated)
- 3 inputs for stop switches and home switch (+24V compatible) with programmable pull-up
- 2 general purpose inputs (+24V compatible) and 2 general purpose outputs (open collector)
- Incremental a/b/n encoder interface (TTL and open-collector signals supported directly)

### Safety features

- Shutdown input – driver will be disabled in hardware as long as this pin is left open or shorted to ground
- Separate supply voltage inputs for driver and digital logic – driver supply voltage may be switched off externally while supply for digital logic and therefore digital logic remains active

### Software

- TMCL: standalone operation or remote controlled operation, program memory (non volatile) for up to 2048 TMCL commands, and PC-based application development software TMCL-IDE available for free.
- Ready for CANopen

### Electrical and mechanical data

- Supply voltage: common supply voltages +12 V DC / +24 V DC / +48 V DC supported (+9 V... +51 V DC)
- Motor current: up to 2.8 A RMS (programmable)
- 0.55... 3.1Nm max. holding torque (depends on motor)
- With NEMA23 (57mm motor flange size) or NEMA24 (60mm motor flange size) stepper motor

**Refer to separate TMCL Firmware Manual, too.**

## TRINAMICS UNIQUE FEATURES – EASY TO USE WITH TMCL

**stallGuard2™** stallGuard2 is a high-precision sensorless load measurement using the back EMF on the coils. It can be used for stall detection as well as other uses at loads below those which stall the motor. The stallGuard2 measurement value changes linearly over a wide range of load, velocity, and current settings. At maximum motor load, the value goes to zero or near to zero. This is the most energy-efficient point of operation for the motor.

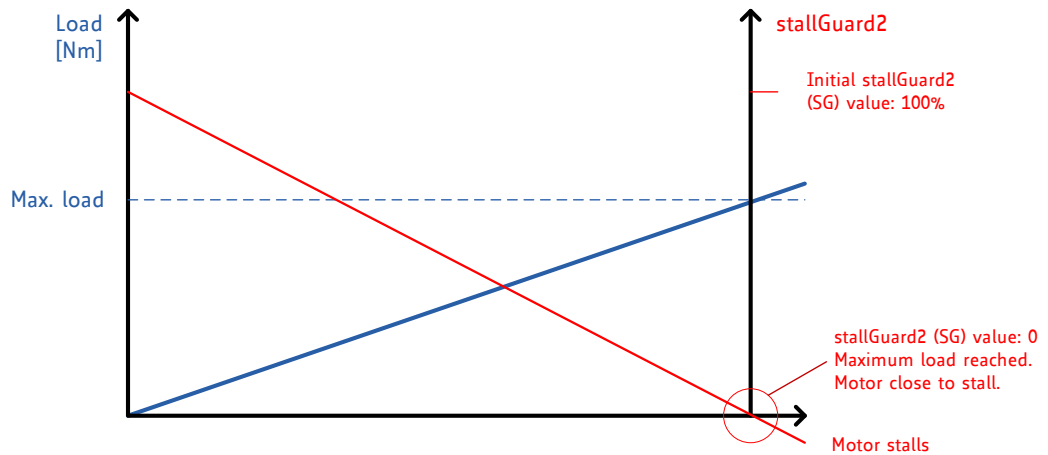

**Figure 1.1** stallGuard2 load measurement SG as a function of load

**coolStep™** coolStep is a load-adaptive automatic current scaling based on the load measurement via stallGuard2 adapting the required current to the load. Energy consumption can be reduced by as much as 75%. coolStep allows substantial energy savings, especially for motors which see varying loads or operate at a high duty cycle. Because a stepper motor application needs to work with a torque reserve of 30% to 50%, even a constant-load application allows significant energy savings because coolStep automatically enables torque reserve when required. Reducing power consumption keeps the system cooler, increases motor life, and allows reducing cost.

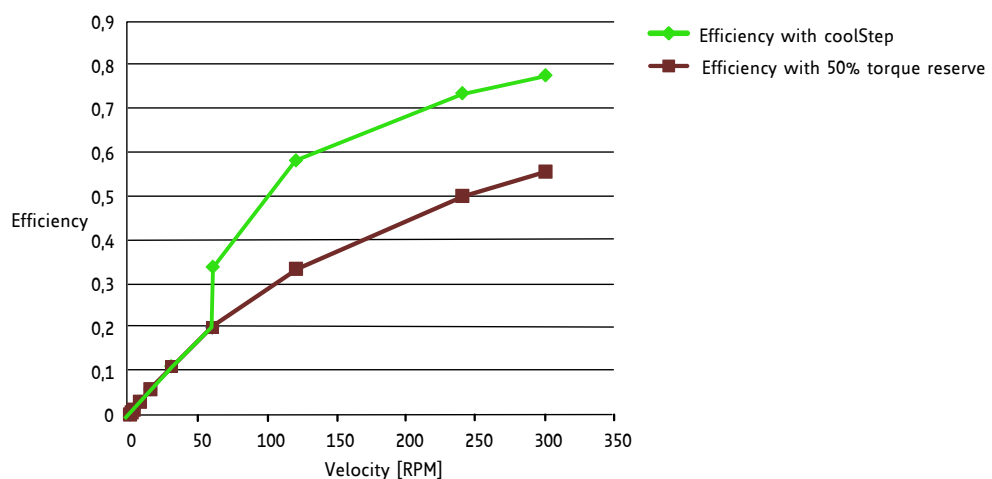

**Figure 1.2** Energy efficiency example with coolStep

## 2 Order Codes

The PD-1160 is currently available with two different stepper motor series (NEMA23 / 57mm flange size or NEMA24 / 60mm flange size):

*With NEMA 23 / 57mm flange size motor:*

The length of the PANdrives is specified without the length of the axis. For the overall length of the product please add 24mm.

Order code	Description	Size (mm <sup>3</sup> )
PD57-1-1160	PANdrive with 0.55Nm max./holding torque	60 x 60 x 58
PD57-2-1160	PANdrive with 1.01Nm max./holding torque	60 x 60 x 68

**Table 2.1 Order codes (PD57-1160)**

*With NEMA 24 / 60mm flange size motor:*

The length of the PANdrives is specified without the length of the axis. For the total length of the product add 24mm.

Order code	Description	Size (mm <sup>3</sup> )
PD60-3-1160	PANdrive with 2.10Nm max./holding torque	60 x 60 x 82
PD60-4-1160	PANdrive with 3.10Nm max./holding torque	60 x 60 x 103

**Table 2.2 Order codes (PD60-1160)**

A cable loom set is available for this module:

Order code	Description
PD-1160-CABLE	Cable loom for PD-1160: <ul style="list-style-type: none"> <li>- 1x cable loom for power connector (length 200mm)</li> <li>- 1x cable loom for communication connector (length 200mm)</li> <li>- 1x cable loom for multipurpose I/O connector (length 200mm)</li> <li>- 1x cable loom for S/D connector (length 200mm)</li> <li>- 1x cable loom for encoder connector (length 200mm)</li> <li>- 1x USB type A connector to mini-USB type B connector cable (length 1.5m)</li> </ul>

**Table 2.3 Cable loom order codes**

### 3 Mechanical and Electrical Interfacing

#### 3.1 PD57-1160 and PD60-1160 Dimensions

##### 3.1.1 PD57-1160 Dimensions

The PD57-1160 includes the TCMC-1160 stepper motor controller/driver module, the magnetic encoder based on sensOstep technology and a NEMA23 bipolar stepper motor. Currently, there is a choice between two NEMA 23/57mm bipolar stepper motors with different lengths and different holding torques.

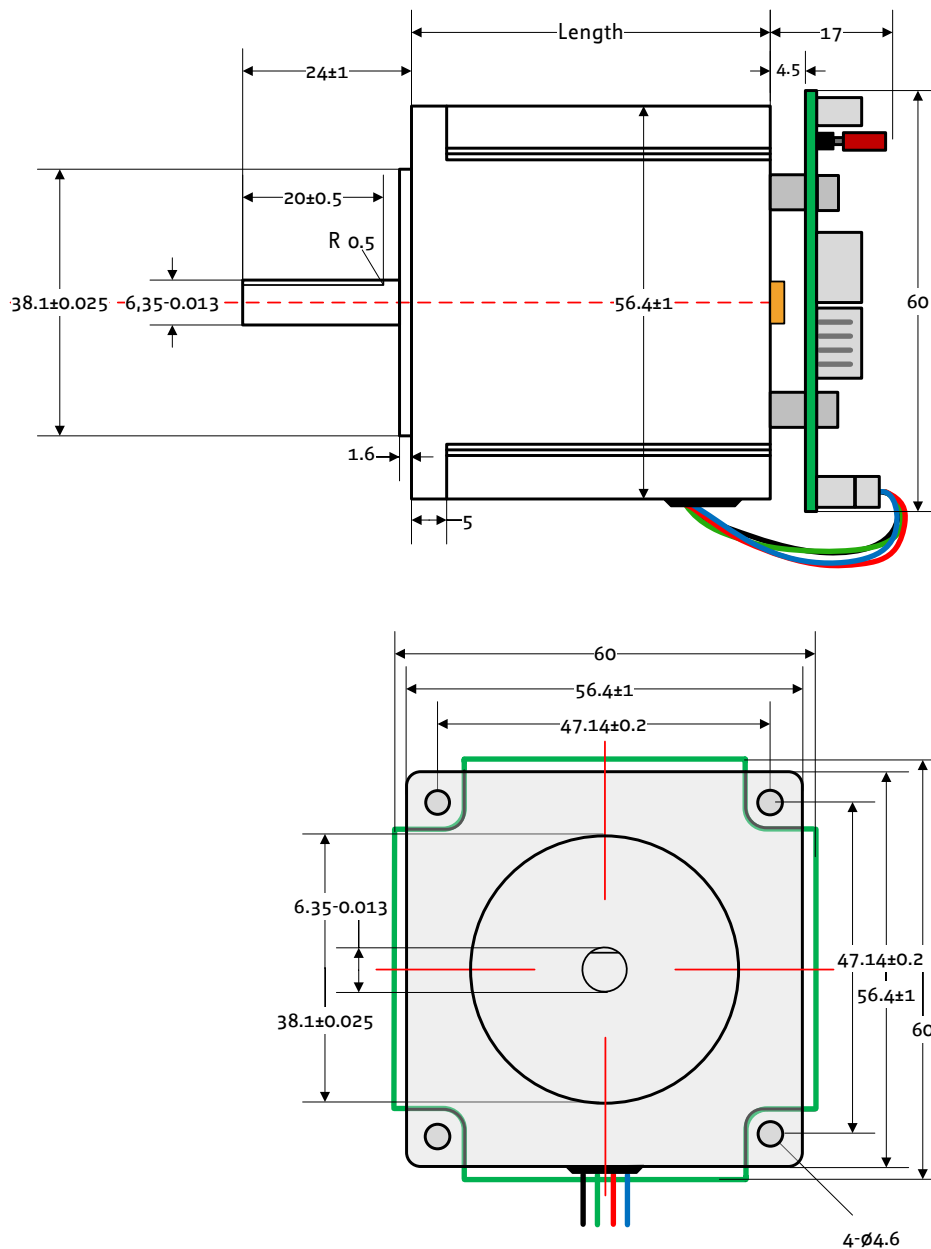

Model	Length (mm)
PD57-1-1160	41
PD57-2-1160	51

Figure 3.1 Dimensions of PD57-1160

### 3.1.2 PD60-1160 Dimensions

Currently, there is a choice between two NEMA 24/60mm bipolar stepper motors with different lengths and different holding torques.

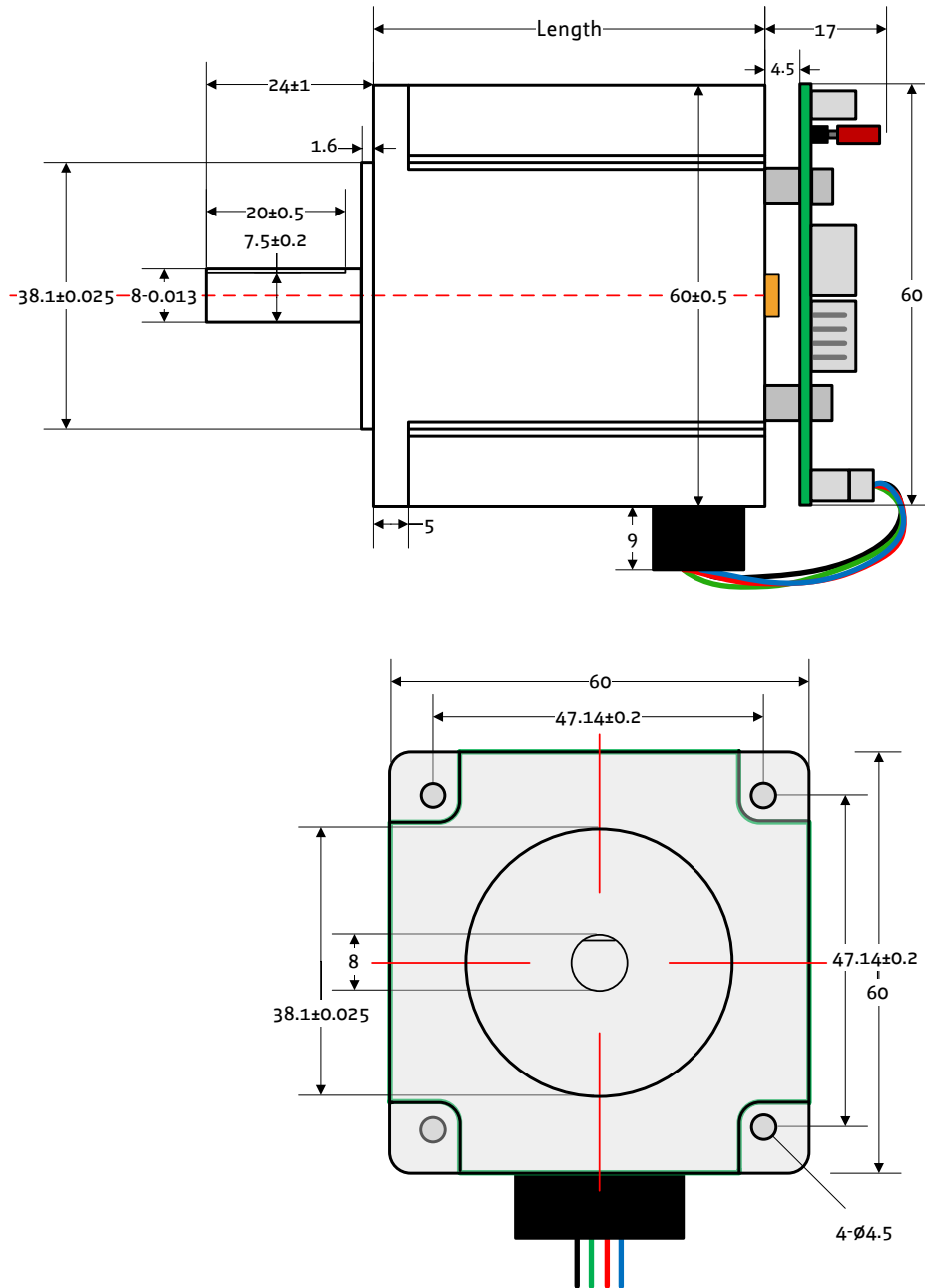

Model	Length (mm)
PD60-3-1160	65
PD60-4-1160	86

Figure 3.2 Dimensions of PD60-1160

### 3.2 Connectors of PD-1160

The PD-1160 offers seven connectors including the motor connector which is used for attaching the motor coils to the electronics. In addition to the power connector there are two connectors for serial communication (mini-USB connector and 5pin connector for RS485 and CAN) and three connectors for Step/Direction, multipurpose input/output signals, and for an external encoder.

The *multipurpose connector* offers two general purpose outputs, two general purpose inputs, two inputs for stop switches and one for an additional home switch.

The *power supply connector* offers separate inputs for driver and for logic power supply plus hardware shutdown input. Leaving the shutdown input open or tying it to ground will disable the motor driver stage in hardware. For operation, this input should be tied to supply voltage.

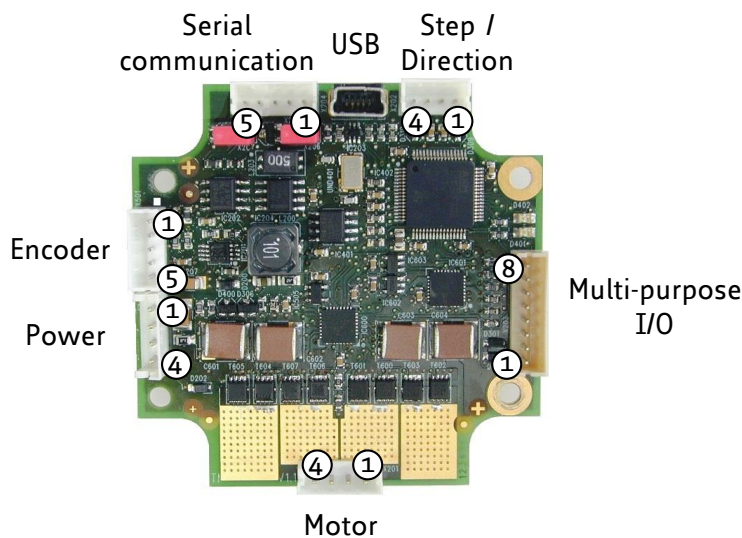

Figure 3.3 Overview connectors

Label	Connector type	Mating connector type
Power Connector	JST B4B-EH-A (JST EH series, 4pins, 2.5mm pitch)	Connector housing: JST EHR-4 Contacts: JST SEH-001T-P0.6 Wire: 0.33mm <sup>2</sup> , AWG 22
Serial communication Connector	JST B5B-PH-K-S (JST PH series, 5pins, 2mm pitch)	Connector housing: JST PHR-5 Contacts: JST SPH-002T-P0.5S Wire: 0.22mm <sup>2</sup> , AWG 24
Multi-purpose I/O Connector	JST B8B-PH-K-S (JST PH series, 8pins, 2mm pitch)	Connector housing: JST PHR-8 Contacts: JST SPH-002T-P0.5S Wire: 0.22mm <sup>2</sup> , AWG 24
Step/Direction Connector	JST B4B-PH-K-S (JST EH series, 4pins, 2mm pitch)	Connector housing: JST PHR-4 Contacts: JST SPH-002T-P0.5S Wire: 0.22mm <sup>2</sup> , AWG 24
Encoder Connector	JST B5B-PH-K-S (JST EH series, 5pins, 2mm pitch)	Connector housing: JST PHR-5 Contacts: JST SPH-002T-P0.5S Wire: 0.22mm <sup>2</sup> , AWG 24
Motor Connector	JST B4B-EH-A (JST PH series, 4pins, 2.5mm pitch)	Connector housing: JST EHR-4 Contacts: JST SEH-001T-P0.6 Wire: 0.33mm <sup>2</sup> , AWG 22
Mini-USB Connector	Molex 500075-1517 Mini USB Type B vertical receptacle	Any standard mini-USB plug

Table 3.1 Connectors and mating connectors, contacts and applicable wire



## 3.2.1 Power Connector

This PANdrive offers separate power supply inputs for digital logic (pin 2) and driver/power stage (pin 1). Both supply inputs use common ground connections (pin 4). This way, power supply for the driver stage may be switched off while still maintaining position and status information when keeping digital logic supply active. Due to internal diode the digital logic supply has to be equal or higher than the driver/power stage supply. Otherwise the diode between driver/power stage supply and digital logic supply might short the separate supplies.

### +U<sub>DRIVER</sub> SUPPLY ONLY

In case power supply is provided only to the power section (pin 1) an internal diode will distribute power to the logic section. So, when separate power supplies are not required it is possible to just use pin 1 and 4 for powering the module. If so, pin 2 (logic supply) and pin 3 (/SHUTDOWN input) can be connected together in order to enable the driver stage.

### ENABLING THE DRIVER STAGE

Connect /SHUTDOWN input to +U<sub>Driver</sub> or +U<sub>Logic</sub> in order to activate the driver stage. Leaving this input open or connecting it to ground will disable driver stage.

A 4-pin JST EH series B4B-EH connector is used as power connector on-board.

	Pin	Label	Description
	1	+V <sub>Driver</sub>	Module + driver stage power supply input
	2	+V <sub>Logic</sub>	(Optional) separate digital logic power supply input
	3	/SHUTDOWN	Shutdown input. Connect this input to +V <sub>Driver</sub> or +V <sub>Logic</sub> in order to activate driver stage. Leaving this input open or connecting it to ground will disable driver stage
	4	GND	Module ground (power supply and signal ground)

Table 3.2 Connector for power supply

### 3.2.1.1 Power Supply

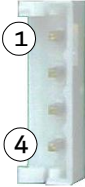

For proper operation care has to be taken with regard to the power supply concept and design. Due to space restrictions the TCMC-1160 module includes about 20 µF / 100 V of supply filter capacitors. These are ceramic capacitors which have been selected for high reliability and long life time.

#### HINTS FOR POWER SUPPLY CABLES

- Keep power supply cables as short as possible.
- Use large diameters for power supply cables.

#### CAUTION!

	<p><b>Add external power supply capacitors!</b></p> <p>It is recommended to connect an electrolytic capacitor of significant size (e.g. 2200 µF / 63V) to the power supply lines next to the PD-1160 especially if the distance to the power supply is large (i.e. more than 2-3m)!</p> <p>Rule of thumb for size of electrolytic capacitor: <math>c = 1000 \frac{\mu\text{F}}{\text{A}} \times I_{\text{SUPPLY}}</math></p> <p>In addition to power stabilization (buffer) and filtering this added capacitor will also reduce any voltage spikes which might otherwise occur from a combination of high inductance power supply wires and the ceramic capacitors. In addition it will limit slew-rate of power supply voltage at the module. The low ESR of ceramic-only filter capacitors may cause stability problems with some switching power supplies.</p>
-------------------------------------------------------------------------------------	-------------------------------------------------------------------------------------------------------------------------------------------------------------------------------------------------------------------------------------------------------------------------------------------------------------------------------------------------------------------------------------------------------------------------------------------------------------------------------------------------------------------------------------------------------------------------------------------------------------------------------------------------------------------------------------------------------------------------------------------------------------------------------------------------------------------------------------------------------------------

	<p><b>Do not connect or disconnect motor during operation!</b></p> <p>Motor cable and motor inductivity might lead to voltage spikes when the motor is disconnected / connected while energized. These voltage spikes might exceed voltage limits of the driver MOSFETs and might permanently damage them. Therefore, always disconnect power supply before connecting / disconnecting the motor.</p>
	<p><b>Keep the power supply voltage below the upper limit of 51V!</b></p> <p>Otherwise the driver electronics will seriously be damaged! Especially, when the selected operating voltage is near the upper limit a regulated power supply is highly recommended. Please see also chapter 7 (operating values).</p>
	<p><b>There is no reverse polarity protection!</b></p> <p>The module will short any reversed supply voltage due to internal diodes of the driver transistors.</p>

## 3.2.2 Serial Communication Connector

The module supports RS485 and CAN communication via this connector.

CAN interface will be de-activated in case USB is connected due to internal sharing of hardware resources.

A 2mm pitch 5-pin JST B5B-PH-K connector is used for serial communication.

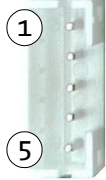
	Pin	Label	Description
	1	CAN_H	CAN bus signal (dominant high)
	2	CAN_L	CAN bus signal (dominant low)
	3	GND	Module ground (system and signal ground)
	4	RS485+	RS485 bus signal (non inverted)
5	RS485-	RS485 bus signal (inverted)	

**Table 3.3 Connector for serial communication**

### 3.2.2.1 RS485

For remote control and communication with a host system the PD-1160 provides a two wire RS485 bus interface. For proper operation the following items should be taken into account when setting up an RS485 network:

1. **BUS STRUCTURE:**

The network topology should follow a bus structure as closely as possible. That is, the connection between each node and the bus itself should be as short as possible. Basically, it should be short compared to the length of the bus.

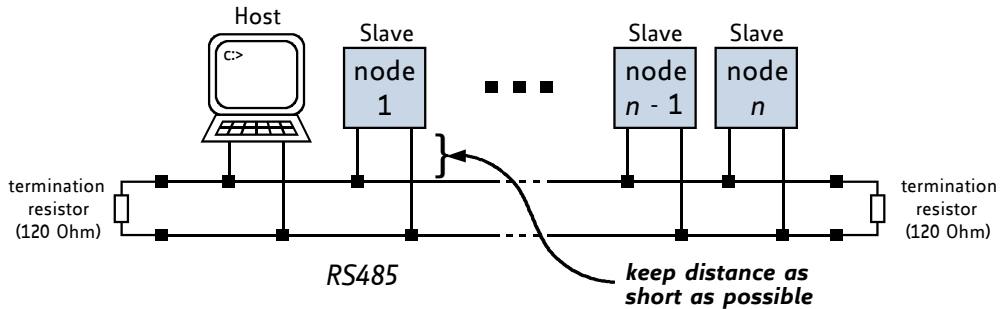

**Figure 6.4: Bus structure**

2. **BUS TERMINATION:**

Especially for longer busses and/or multiple nodes connected to the bus and/or high communication speeds, the bus should be properly terminated at both ends. The PD-1160 does offer on-board termination resistors which can be activated with the help of a jumper. The jumper has to be removed for units not connected to one end of the bus!

3. **NUMBER OF NODES:**

The RS485 electrical interface standard (EIA-485) allows up to 32 nodes to be connected to a single bus. The bus transceiver used on the PD-1160 units (SN65HVD485ED) has 1/2 of the standard bus load and allows a maximum of 64 units to be connected to a single RS485 bus.

4. **NO FLOATING BUS LINES:**

Avoid floating bus lines while neither the host/master nor one of the slaves along the bus line is transmitting data (all bus nodes switched to receive mode). Floating bus lines may lead to communication errors. In order to ensure valid signals on the bus it is recommended to use a resistor network connecting both bus lines to well defined logic levels. In contrast to the termination resistors this network is normally required just once per bus. Certain RS485 interface converters available for PCs already include these additional resistors (e.g. USB-2-485).

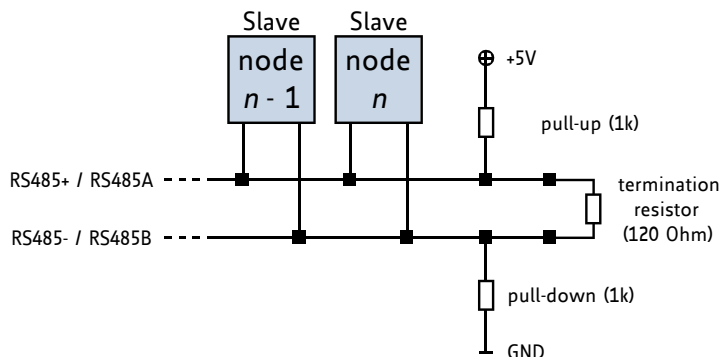

**Figure 3.5 Bus lines with resistor network**

### 3.2.2.2 CAN

For remote control and communication with a host system the PD-1160 provides a CAN bus interface. Please note that the CAN interface is not available in case USB is connected. For proper operation the following items should be taken into account when setting up a CAN network:

1. **BUS STRUCTURE:**

The network topology should follow a bus structure as closely as possible. That is, the connection between each node and the bus itself should be as short as possible. Basically, it should be short compared to the length of the bus.

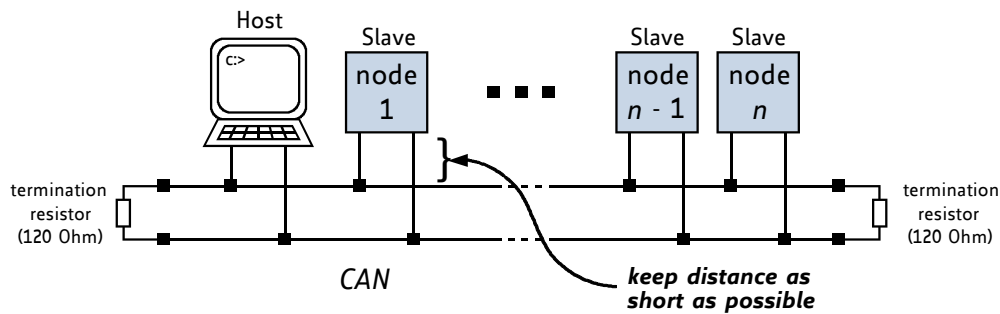

**Figure 3.6 CAN bus structure**

2. **BUS TERMINATION:**

Especially for longer busses and/or multiple nodes connected to the bus and/or high communication speeds, the bus should be properly terminated at both ends. The PD-1160 does offer on-board termination resistors which can be activated with the help of a jumper (see chapter 7). The jumper has to be removed for units not connected to one end of the bus!

3. **NUMBER OF NODES:**

The bus transceiver used on the PD-1160 units (TJA1050T or similar) supports at least 110 nodes under optimum conditions. Practically achievable number of nodes per CAN bus highly depends on bus length (longer bus -> less nodes) and communication speed (higher speed -> less nodes).

### 3.2.3 Multipurpose I/O Connector

A 2mm pitch 8-pin JST B8B-PH-K connector is used for connecting general purpose inputs, home and stop switches and outputs to the unit:

Pin	Label	Description
1	OUT_o	General purpose output, open drain (max. 1A) Integrated freewheeling diode connected to +V <sub>Logic</sub>
2	OUT_1	General purpose output, open drain (max. 1A) Integrated freewheeling diode connected to +V <sub>Logic</sub>
3	IN_o	General purpose input (analog and digital), +24V compatible Resolution when used as analog input: 12bit (0..4095)
4	IN_1	General purpose input (analog and digital), +24V compatible Resolution when used as analog input: 12bit (0..4095)
5	STOP_L	Left stop switch input (digital input), +24V compatible, programmable internal pull-up to +5V
6	STOP_R	Right stop switch input (digital input), +24V compatible, programmable internal pull-up to +5V
7	HOME	Home switch input (digital input), +24V compatible, programmable internal pull-up to +5V
8	GND	Module ground (system and signal ground)

**Table 3.4 Multipurpose I/O connector**

**Note:**

All inputs have resistor based voltage dividers with protection diodes. These resistors also ensure a valid GND level when left unconnected.

For reference switch inputs (STOP\_L, STOP\_R, HOME) a 1k pull-up resistor to +5V can be activated (separately for each input). Then these inputs have a default (unconnected) logic level of "1" and an external switch to GND can be connected.

#### 3.2.3.1 Digital Inputs STOP\_L, STOP\_R, and HOME

The eight pin connector of the PD-1160 provides three reference switch digital inputs STOP\_L, STOP\_R and HOME. All three inputs accept up to +24 V input signals. They are protected against these higher voltages using voltage resistor dividers together with limiting diodes against voltages below 0 V (GND) and above +3.3 V DC.

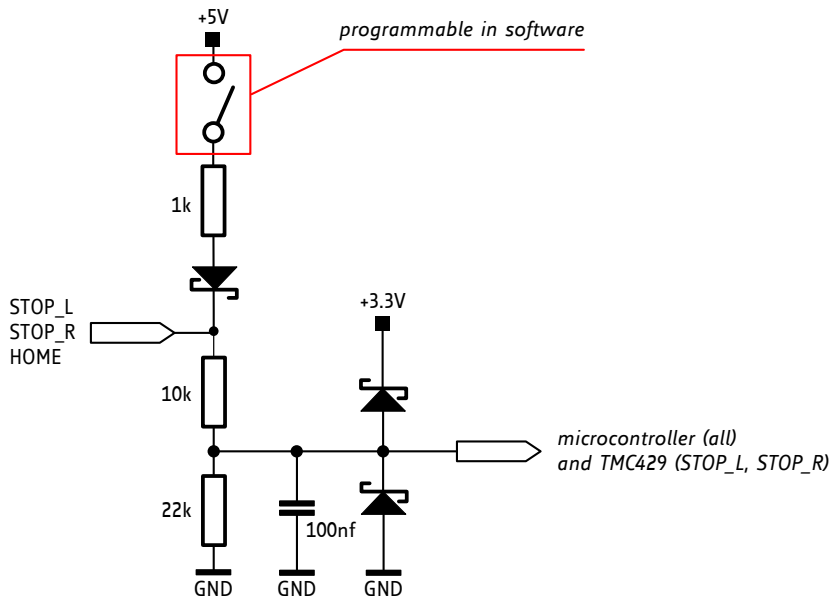

**Figure 3.6 STOP\_L, STOP\_R and HOME inputs (simplified input circuit)**

All three digital inputs are connected to the on-board processor and can be used as general purpose digital inputs!

### 3.2.3.2 General Purpose Inputs IN\_0 and IN\_1

The eight pin connector of the PD-1160 provides two general purpose inputs which may be used as either digital or analog inputs.

#### GENERAL PURPOSE INPUTS AS ANALOG INPUTS

As analog input they offer a full scale input range of 0... +10 V with a resolution of the internal analog-to-digital converter of the microcontroller of 12bit (0... 4095). The input is protected against higher voltages up to +24 V using voltage resistor dividers together with limiting diodes against voltages below 0 V (GND) and above +3.3 V DC.

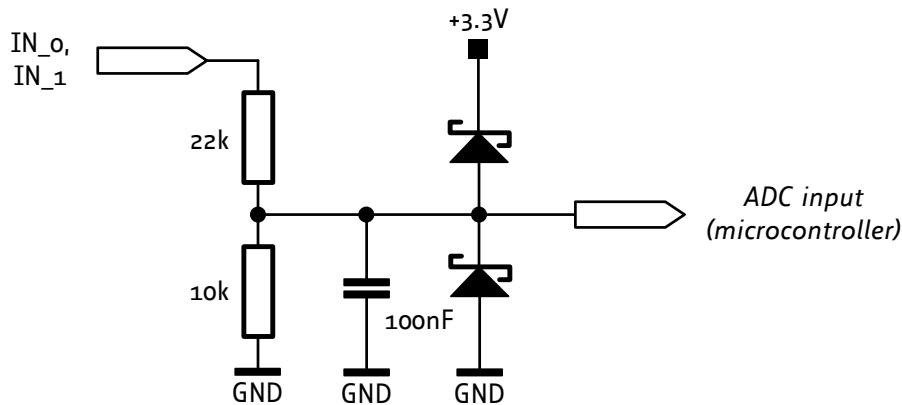

Figure 3.7 General purpose inputs (simplified input circuit)

### 3.2.3.3 Outputs OUT\_0, OUT\_1

The eight pin connector of the PD-1160 offers two general purpose outputs OUT\_0 and OUT\_1. These two outputs are open-drain outputs and can sink up to 1 A each. The outputs of the N-channel MOSFET transistors are connected to freewheeling diodes each for protection against voltage spikes especially from inductive loads (relays etc.) above supply voltage.

- In case free-wheeling diodes are connected to VDD supply voltage: None of the two outputs should be connected to any voltage above supply voltage of the module.
- It is recommended to connect  $+V_{logic}$  of the power connector to the power supply output in case the outputs OUT\_0/1 are used to switch inductive loads (e.g. relays etc.).

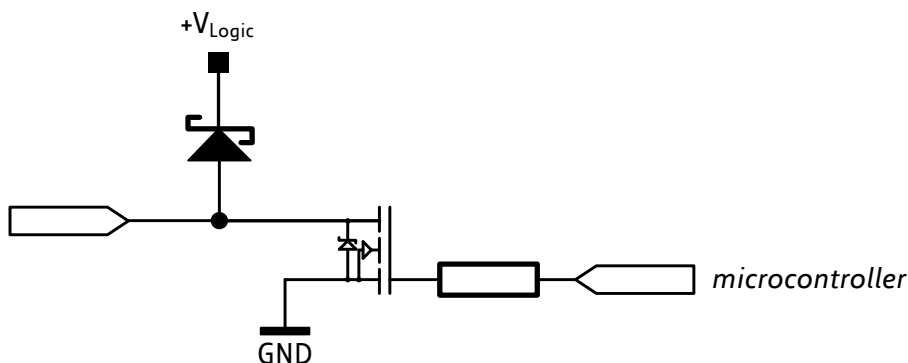

Figure 3.8 General purpose outputs

### 3.2.4 Step/Direction Connector

A 2mm pitch 4-pin JST B4B-PH-K connector is used for step and direction input signals. This is an option in case the on-board controller is used for configuration of the driver stage, only. The Step/Direction input is optically isolated and will allow direct control of the driver stage.

Please do not attach any signal to this input if the on-board motion controller is used! Otherwise step or direction signal connected here might interfere with signals generated on-board.

Pin	Label	Description
1	COM	Common supply for the opto-coupler inputs (+5V... +24V)
2	ENABLE	Enable signal input (function depends on firmware)
3	STEP	Step signal input (connected to step input of TMC262 driver IC)
4	DIRECTION	Direction signal (connected to direction input of TMC262 driver IC)

**Table 3.4 Connector for step/direction signals**

#### 3.2.4.1 Step / Direction / Enable Inputs

The inputs Step, Direction and Enable are electrically (optically) isolated from the power supply and all other signals of the module. These inputs have one common reference input COMMON.

The COMMON input should be connected to a positive supply voltage between +5 V and +24 V. Step / Direction / Enable signals might be driven either by open-collector / open-drain outputs or by push-pull outputs.

In case of push-pull outputs the COMMON supply voltage should be equal / similar to the high signal voltage level of the push-pull drivers.

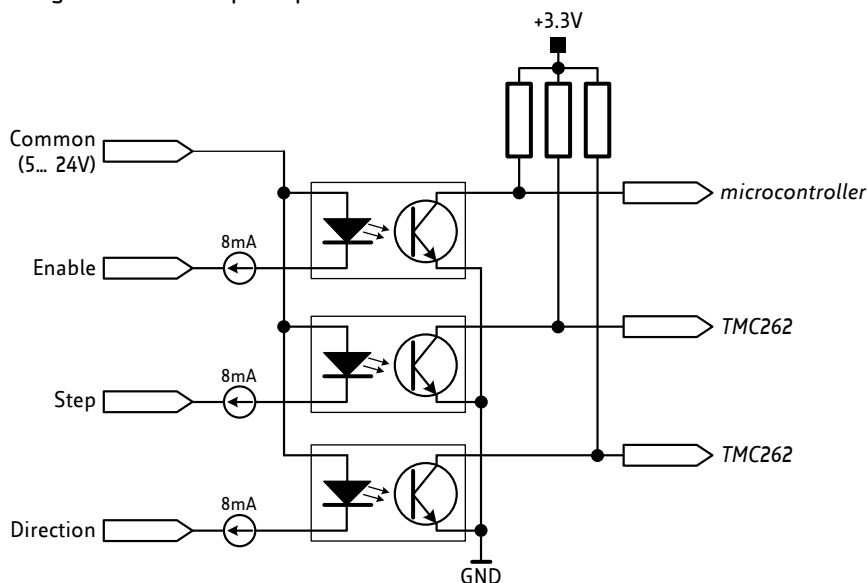
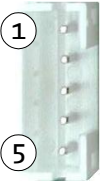

**Figure 3.9 Step / Direction / Enable inputs**

### 3.2.5 Encoder Connector

The module supports an external incremental a/b/n encoder via this connector. The external encoder may be used in addition or as an alternative to the internal / on-board sensOstep encoder.

A 2mm pitch 5-pin JST B5B-PH-K connector is used for connecting an external encoder with TTL (+5 V push-pull) or open-collector signals directly:

	Pin	Label	Description
	1	GND	Module ground (system and signal ground)
	2	+5V	+5V supply output for external encoder circuit (100 mA max.)
	3	ENC_A	Encoder a channel input (internal pull-up)
	4	ENC_B	Encoder b channel input (internal pull-up)
	5	ENC_N	Optional encoder n / index channel input (internal pull-up)

**Table 3.5 Connector for an external incremental encoder**

#### 3.2.5.1 Encoder Inputs

The PD-1160 offers a dedicated encoder input for incremental a/b encoders with optional n / index-channel.

Encoders with +5 V push-pull (TTL) signals or open-collector signals (on-board pull-ups) might be connected directly. This connector offers a +5 V supply output for supply of the encoder circuit. Up to 100mA might be drawn from this output.

Connecting an external encoder is an option. An external encoder might be used in addition or as alternative to the internal sensOstep encoder.

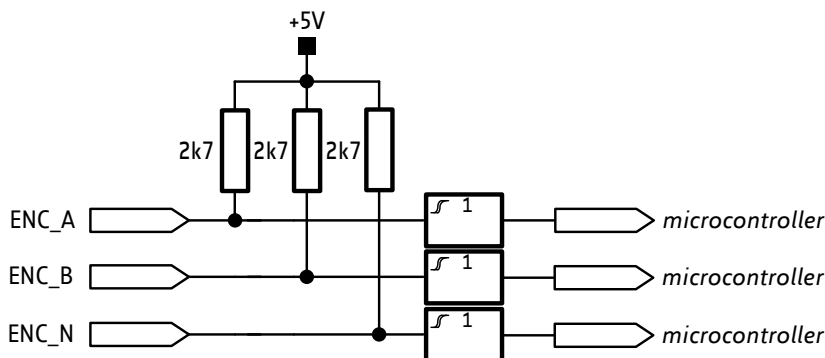

**Figure 3.9 Encoder a/b/n inputs**



### 3.2.6 Motor Connector

Both motor coil windings (bipolar stepper motor) are connected to the motor connector.

	Pin	Label	Description
	1	OA1	Motor coil A
	2	OA2	Motor coil A
	3	OB1	Motor coil B
4	OB2	Motor coil B	

Figure 3.4 Motor connector

TMCM-1160	Q5718 motor		
Motor connector pin	Cable colour	Coil	Description
1	Black	A	Motor coil A pin 1
2	Green	A-	Motor coil A pin 2
3	Red	B	Motor coil B pin 1
4	Blue	B-	Motor coil B pin 2



**CAUTION!**

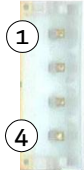
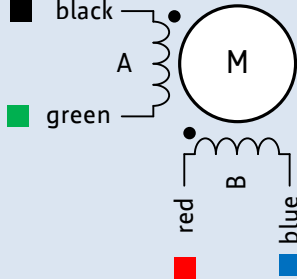

**Keep the electronics free of (metal) particles!**

The integrated sensOstep™ encoder uses a magnet at the end of the motor axis in order to monitor position. The magnet naturally attracts especially tiny metal particles. These particles might be held on the top side of the PCB and even worse – start moving in accordance with the rotating magnetic field as soon as the motor starts moving. This might lead to shorts of electronic contacts / wires on the board and totally erratic behavior of the module! Use compressed air for cleaning the module if necessary.

### 3.2.7 Mini-USB Connector

A 5-pin standard mini-USB connector is available on board. This module supports USB 2.0 full-speed (12Mbit/s) connections.

Please note:

- On-board digital core logic (mainly processor and EEPROM) will be powered via USB in case no other supply is connected. The USB connection might be used to set parameters / download TMCL programs or perform firmware updates while power supply for the module (and the rest of the machine) has been switched off or is not connected.
- CAN interface will be de-activated as soon as USB is connected due to internal sharing of hardware resources.

	Pin	Label	Description
	1	VBUS	+5V supply from host
	2	D-	Data -
	3	D+	Data +
	4	ID	Not connected
	5	GND	Module ground (system and signal ground)

**Table 3.6 Mini USB connector**

For remote control and communication with a host system the PD-1160 provides a USB 2.0 full-speed (12Mbit/s) interface (mini-USB connector). As soon as a USB-Host is connected the module will accept commands via USB.

#### USB BUS POWERED OPERATION MODE

The PD-1160 supports both, USB self powered operation (when an external power is supplied via the power supply connector) and USB bus powered operation, (no external power supply via power supply connector).

On-board digital core logic will be powered via USB in case no other supply is connected (USB bus powered operation). The digital core logic comprehends the microcontroller itself and also the EEPROM. The *USB bus powered operation mode* has been implemented to enable configuration, parameter settings, read-outs, firmware updates, etc. by just connecting an USB cable between module and host PC. No additional cabling or external devices (e.g. power supply) are required.

Please note that the module might draw current from the USB +5 V bus supply even in USB self powered operation depending on the voltage level of this supply.

Motor movements are not possible in this operation mode. Therefore, connect the power connector and change to *USB self powered operation mode*.

## 4 Jumpers

Most settings of the board are done through the software. Nevertheless, two jumpers are available for configuration.

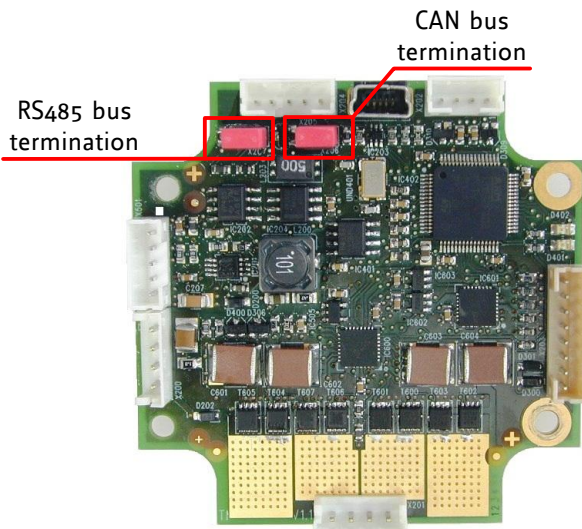

Figure 4.1 RS485 and CAN bus termination

### 4.1 RS485 Bus Termination

The board includes a 120 Ohm resistor for proper bus termination of the RS485 interface. When this jumper is closed, the resistor will be placed between the two differential bus lines RS485+ and RS485-.

### 4.2 CAN Bus Termination

The board includes a 120 Ohm resistor for proper bus termination of the CAN interface. When this jumper is closed, the resistor will be placed between the two differential bus lines CAN\_H and CAN\_L.

## 5 Reset to Factory Defaults

It is possible to reset the PD-1160 to factory default settings without establishing a communication link. This might be helpful in case communication parameters of the preferred interface have been set to unknown values or got accidentally lost.

For this procedure two pads on the bottom side of the board have to be shorted (see Figure 5.1).

*Short these two pads.*



### PERFORM THE FOLLOWING STEPS:

1. Power supply off and USB cable disconnected
2. Short two pads as marked in Figure 5.1
3. Power up board (power via USB is sufficient for this purpose)
4. Wait until the on-board red and green LEDs start flashing fast (this might take a while)
5. Power-off board (disconnect USB cable)
6. Remove short between pads
7. After switching on power-supply / connecting USB cable all permanent settings have been restored to factory defaults

**Figure 5.1 Reset to factory default settings**

## 6 On-board LEDs

The board offers two LEDs in order to indicate board status. The function of both LEDs is dependent on the firmware version. With standard TMCL firmware the green LED should be flashing during operation and the red LED should be off.

When there is no valid firmware programmed into the board or during firmware update the red and green LEDs are permanently on.

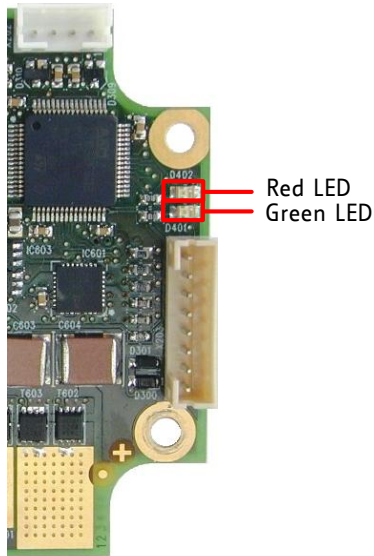

**BEHAVIOR OF LEDs WITH STANDARD TMCL FIRMWARE**

Status	Label	Description
Heartbeat	Run	The green LED flashes during operation.
Error	Error	The red LED lights up if an error occurs.

**Figure 6.1 on-board LEDs**

## 7 Operational Ratings

The operational ratings show the intended or the characteristic ranges and should be used as design values.

***In no case shall the maximum values be exceeded!***

### GENERAL OPERATIONAL RATINGS OF THE MODULE

Symbol	Parameter	Min	Typ	Max	Unit
$+V_{Driver} / +V_{Logic}$	Power supply voltage for operation	9	12, 24, 48	51	V DC *)
$I_{USB}$	USB supply current when USB bus powered (+5V USB supply)		70		mA
$I_{COIL\_peak}$	Motor coil current for sine wave peak (chopper regulated, adjustable via software)	0		4	A
$I_{COIL\_RMS}$	Continuous motor current (RMS)	0		2.8	A
$I_{SUPPLY}$	Power supply current		$\ll I_{COIL}$	$1.4 * I_{COIL}$	A
$T_{ENV}$	Environment temperature at +48V supply and rated current (100% duty-cycle, no forced cooling required)			40	°C
$T_{ENV}$	Environment temperature at +24V supply and rated current (100% duty-cycle, no forced cooling required)			50	°C

**Table 7.1 General operational ratings of module**

\*) Attention: due to the internal diode between  $V_{Driver}$  and  $V_{Logic}$   $V_{Logic}$  should be always equal or higher than  $V_{Driver}$

### GENERAL OPERATIONAL RATINGS OF STEP/DIRECTION INPUT

Symbol	Parameter	Min	Type	Max	Unit
$V_{COMMON}$	Supply voltage for common supply input for step, direction and enable (inputs have negative logic)		5... 24	27	V
$V_{STEP/DIR/ENABLE\_ON}$	Signal voltage at step, direction and enable input (active, opto-coupler on)	3.5	4.5... 24	30	V
$V_{STEP/DIR/ENABLE\_OFF}$	Signal voltage at step, direction and enable input (inactive, opto-coupler off)	-5.5	0	2	V
$V_{STEP/DIR/ENABLE\_ON}$	Opto-coupler current when switched on (internally regulated)		6... 8		mA
$f_{STEP}$	Step frequency			1 *)	MHz

**Table 7.2 Operational ratings of Step/Dir input**

\*) Maximum frequency for +5 V TTL level step signals is with 50 % duty cycle.

**OPERATIONAL RATINGS OF THE GENERAL PURPOSE INPUTS/OUTPUTS**

Symbol	Parameter	Min	Type	Max	Unit
$V_{STOP\_L/R/HOME}$	Input voltage for STOP_L/R/HOME	0		24	V
$V_{STOP\_L/R/HOME\_L}$	Low level voltage for STOP_L/R/HOME	0		1.3	V
$V_{STOPL/R/HOME\_H}$	High level voltage for STOP_L/R/HOME (internal programmable 1k pull-up to +5V)	3		24	V
$V_{IN\_0/1\_digital}$	Input voltage for IN_0 and IN_1 when used as digital input	0		24	V
$V_{IN\_0/1\_analog}$	Full range input voltage for IN_0 and IN_1 when used as analog input	0		10	V
$V_{IN\_0/1\_L}$	Low level voltage for IN_0 and IN_1 when used as digital input (internal 10k pull-down)	0		1.3 *)	V
$V_{IN\_0/1\_H}$	High level voltage for IN_0 and IN_1 when used as digital input	3 *)		24	V
$V_{OUT\_0/1}$	Voltage at open collector output	0		$V_{LOGIC} + 0.5^{**})$	V
$I_{OUT\_0/1}$	Output sink current at open collector outputs			1	A

**Table 7.3 Operational ratings of the general purpose inputs/outputs**

\*) this voltage is programmable (internal 12bit ADC)

\*\*\*) limited to module supply voltage + 0.5V due to integrated freewheeling diode between general purpose output and module supply voltage

## 8 Torque Curves

TRINAMIC offers the TCM-1160 in combination with two different stepper motor series: QSH5718 and QSH6018. The following paragraphs will show you the curves of each PANdrive.

### 8.1 Curves of PD57-1160

#### 8.1.1 PD57-1-1160 Torque Curves

TCM-1160 – QSH5718-41-28-055 – Torque versus Velocity

$V_S = 24V$ ;  $I_{coil} = 2.8A$  [RMS]; 256 Microsteps

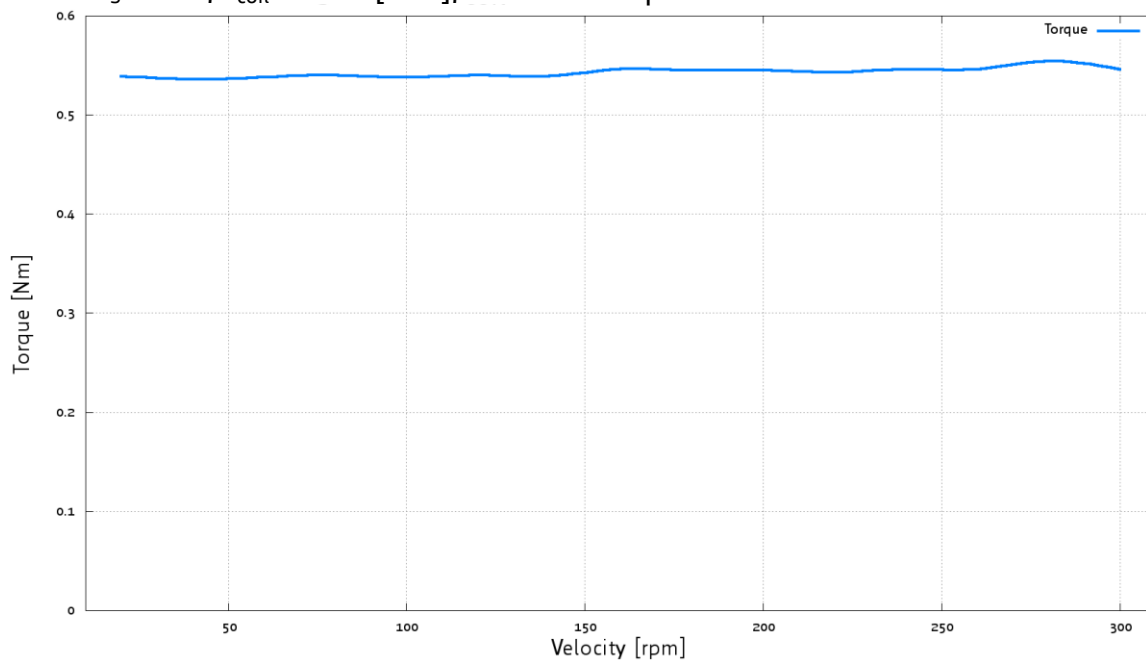

TCM-1160 – QSH5718-41-28-055 – Torque versus Velocity

$V_S = 24V$ ;  $I_{coil} = 2.8A$  [RMS]; 256 Microsteps

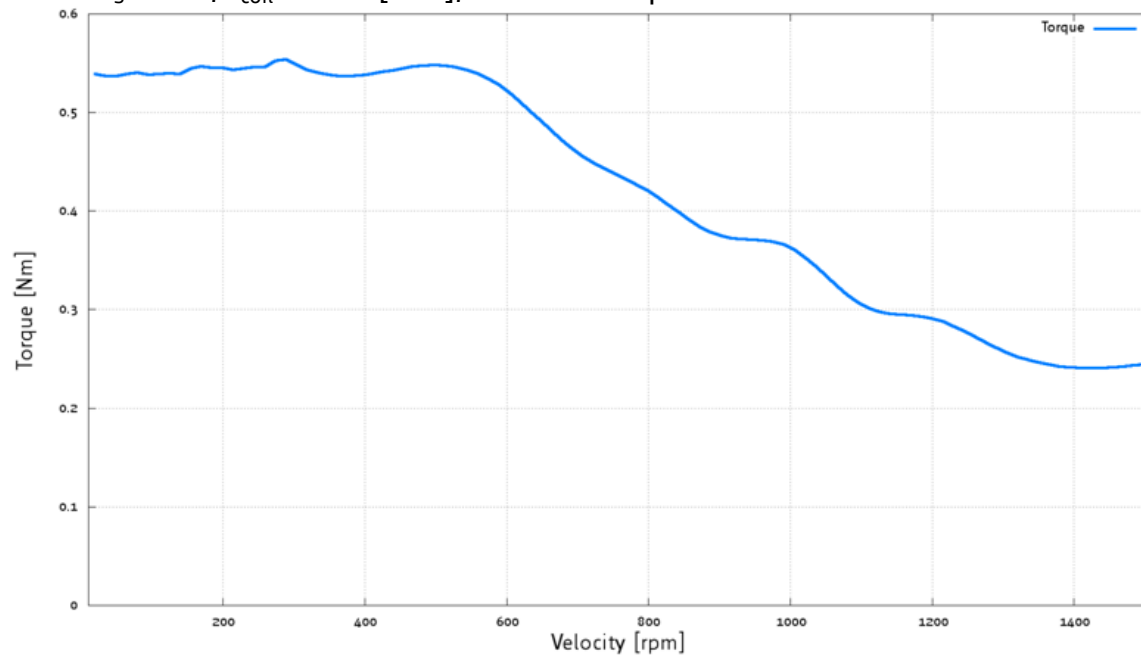
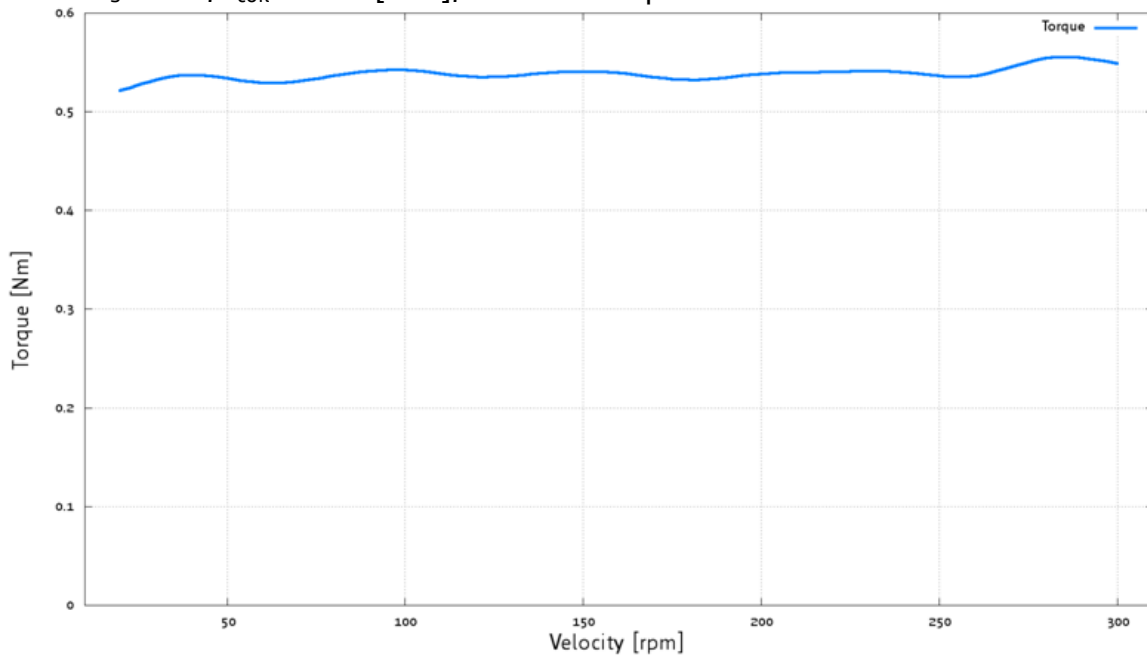

Figure 8.1 Torque curves PD57-1-1160,  $V_S = 24 V$  DC



TMC1160 – QSH5718-41-28-055 – Torque versus Velocity  
 $V_S = 48V$ ;  $I_{coil} = 2.8A$  [RMS]; 256 Microsteps



TMC1160 – QSH5718-41-28-055 – Torque versus Velocity  
 $V_S = 48V$ ;  $I_{coil} = 2.8A$  [RMS]; 256 Microsteps

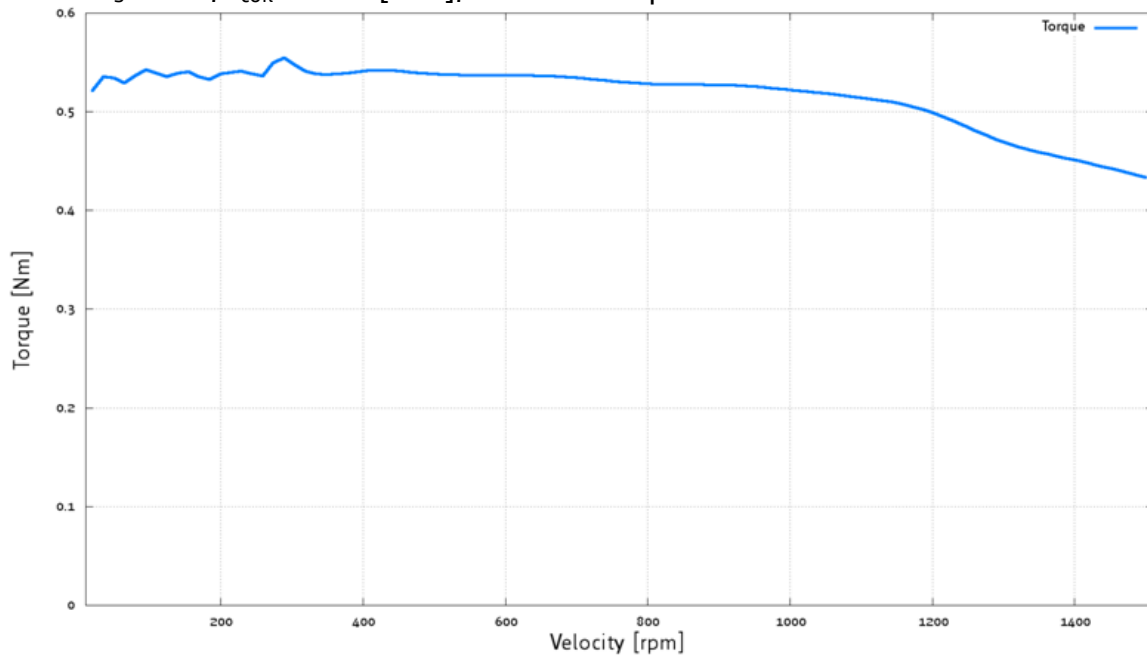
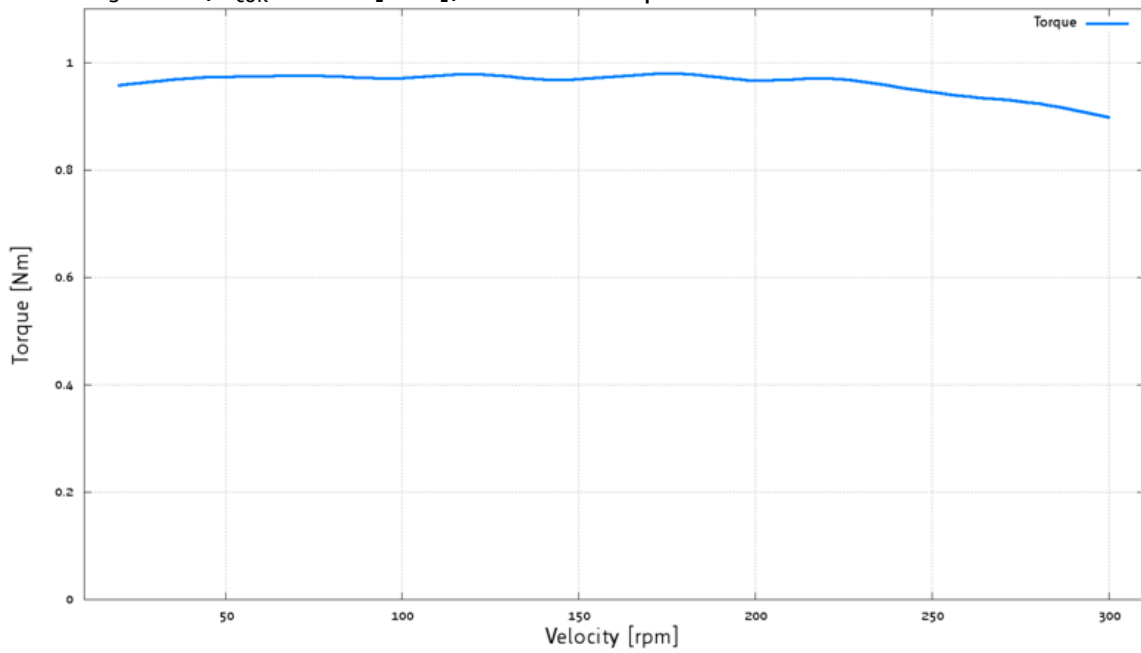

Figure 8.2 Torque curves PD57-1-1160,  $V_S = 48 V$  DC

### 8.1.2 PD57-2-1160 Torque Curves

TMCM-1160 – QSH5718-51-28-101 – Torque versus Velocity  
 $V_S = 24V$ ;  $I_{coil} = 2.8A$  [RMS]; 256 Microsteps



TMCM-1160 – QSH5718-51-28-101 – Torque versus Velocity  
 $V_S = 24V$ ;  $I_{coil} = 2.8A$  [RMS]; 256 Microsteps

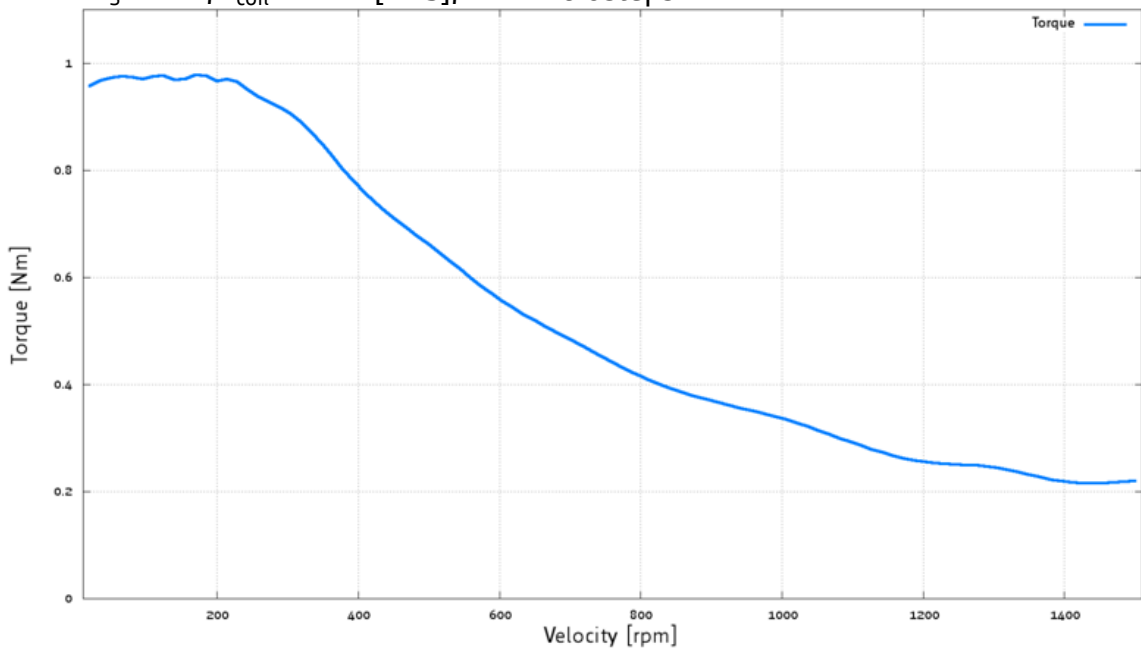
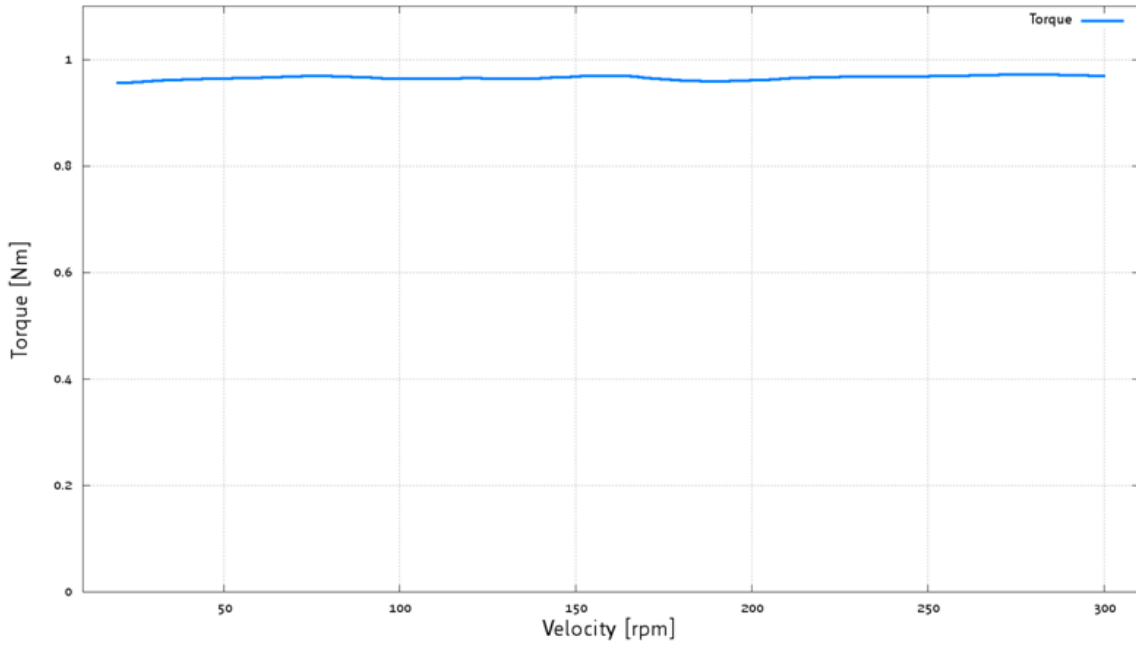

Figure 8.3 Torque curves PD57-2-1160,  $V_S = 24 V$  DC

TMCM-1160 – QSH5718-51-28-101 – Torque versus Velocity  
 $V_S = 48V$ ;  $I_{coil} = 2.8A$  [RMS]; 256 Microsteps



TMCM-1160 – QSH5718-51-28-101 – Torque versus Velocity  
 $V_S = 48V$ ;  $I_{coil} = 2.8A$  [RMS]; 256 Microsteps

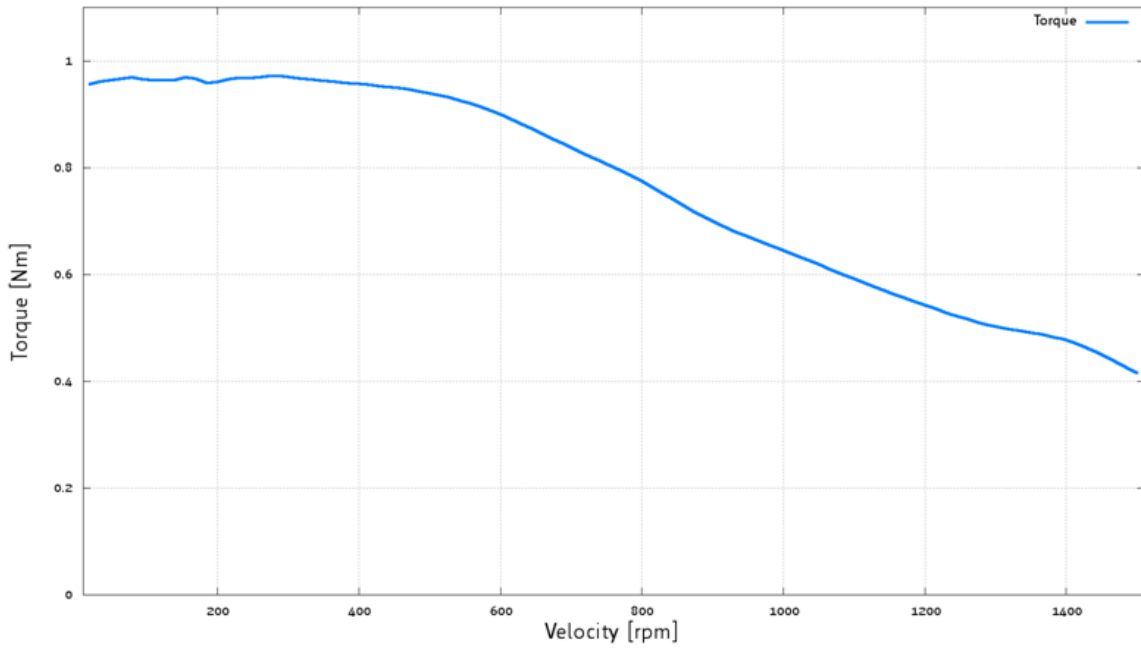

Figure 8.4 Torque curves PD57-2-1160,  $V_S = 48 V$  DC

## 8.2 Curves of PD60-1160

### 8.2.1 PD60-3-1160 Torque Curves

TMCM-1160 – QSH6018-65-28-210 – Torque versus Velocity  
 $V_S = 24V$ ;  $I_{coil} = 2.8A$  [RMS]

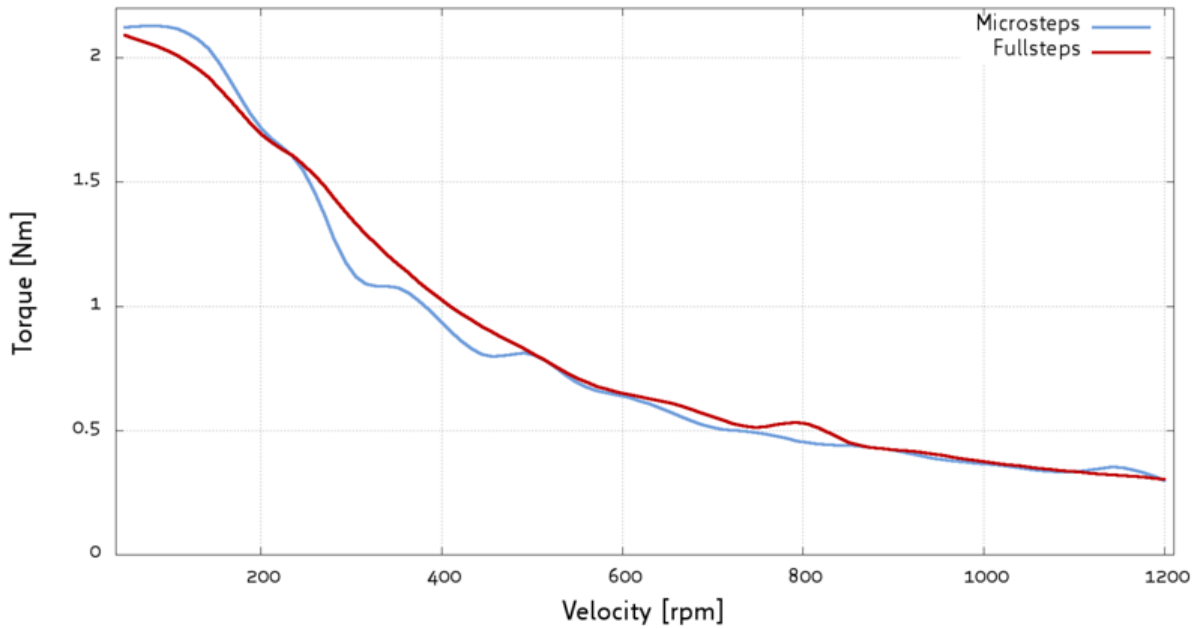

Figure 8.5 Torque curves PD60-3-1160,  $V_S = 24 V$  DC

TMCM-1160 – QSH6018-65-28-210 – Torque versus Velocity  
 $V_S = 48V$ ;  $I_{coil} = 2.8A$  [RMS]

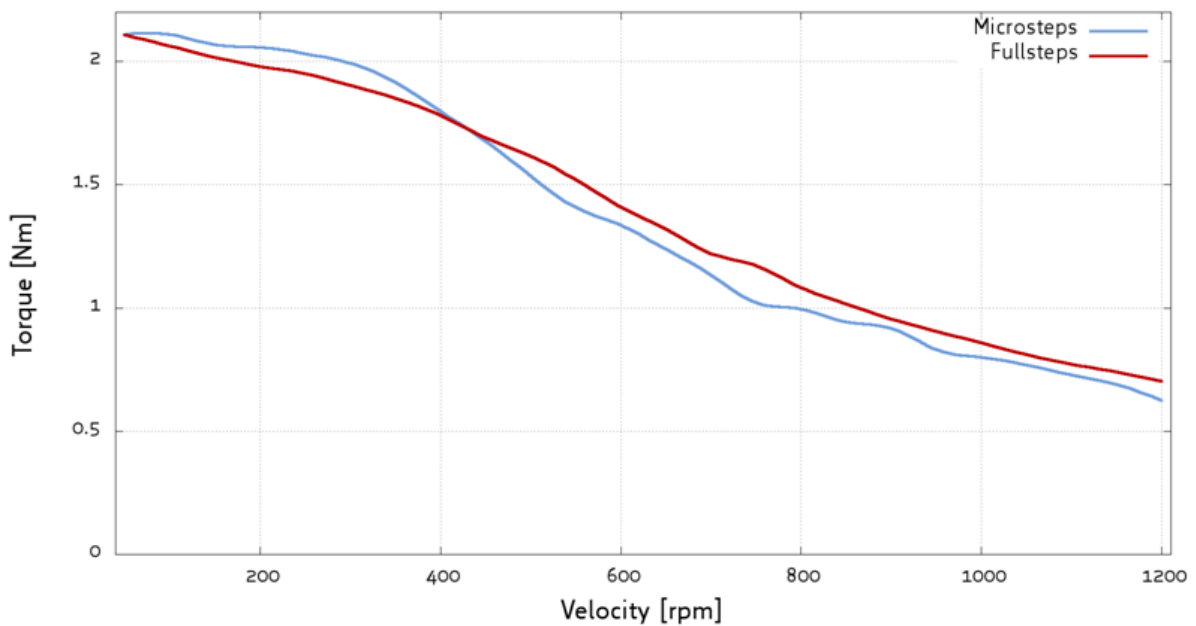

Figure 8.6 Torque curves PD60-3-1160,  $V_S = 48 V$  DC

### 8.2.2 PD60-4-1160 Torque Curves

TMCM-1160 – QSH6018-86-28-310 – Torque versus Velocity  
 $V_S = 24V$ ;  $I_{coil} = 2.8A$  [RMS]

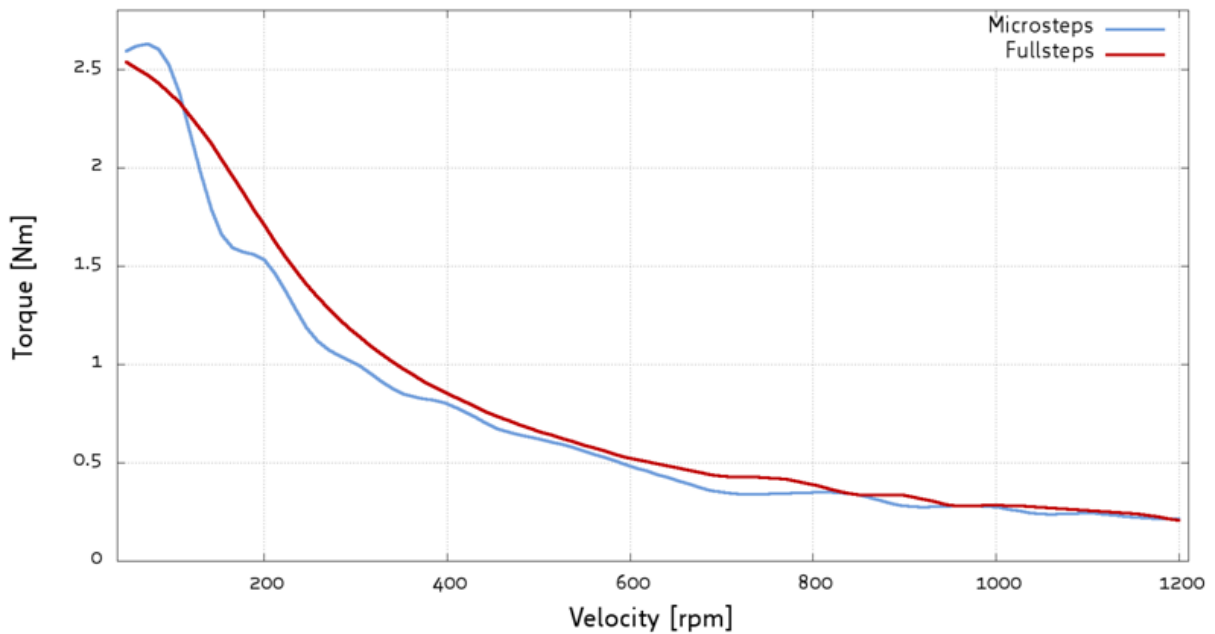

Figure 8.7 Torque curves PD60-4-1160,  $V_S = 24 V$  DC

TMCM-1160 – QSH6018-86-28-310 – Torque versus Velocity  
 $V_S = 48V$ ;  $I_{coil} = 2.8A$  [RMS]; Fullsteps

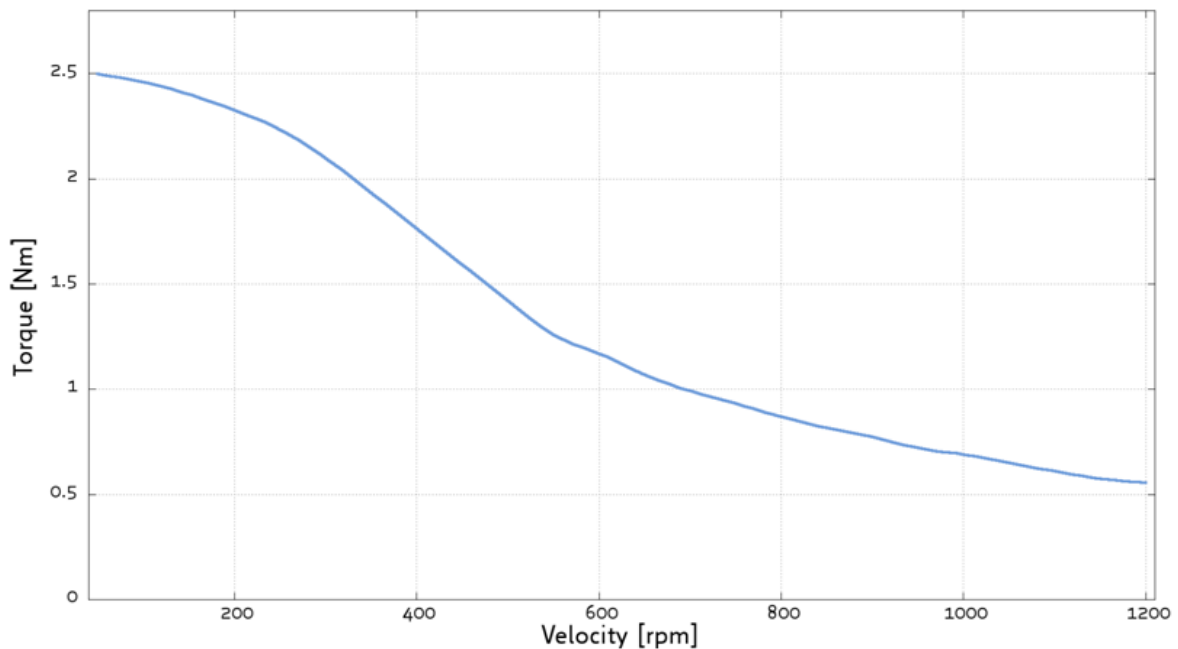

Figure 8.8 Torque curves PD60-4-1160,  $V_S = 48 V$  DC

## 9 Functional Description

The PD-1160 is a highly integrated mechatronic device which can be controlled via several serial interfaces. Communication traffic is kept low since all time critical operations, e.g. ramp calculations are performed on board. Common supply voltages are +12VDC / +24VDC / +48VDC. The PANdrive is designed for both: direct mode and standalone operation. Full remote control of device with feedback is possible. The firmware of the module can be updated via any of the serial interfaces.

In Figure 9.1 the main parts of the PD-1160 are shown:

- the microprocessor, which runs the TMCL operating system (connected to TMCL memory),
- the motion controller, which calculates ramps and speed profiles internally by hardware,
- the power driver with stallGuard2 and its energy efficient coolStep feature,
- the MOSFET driver stage,
- the QSH stepper motor, and
- the sensOstep encoder with resolutions of 10bit (1024 steps) per revolution.

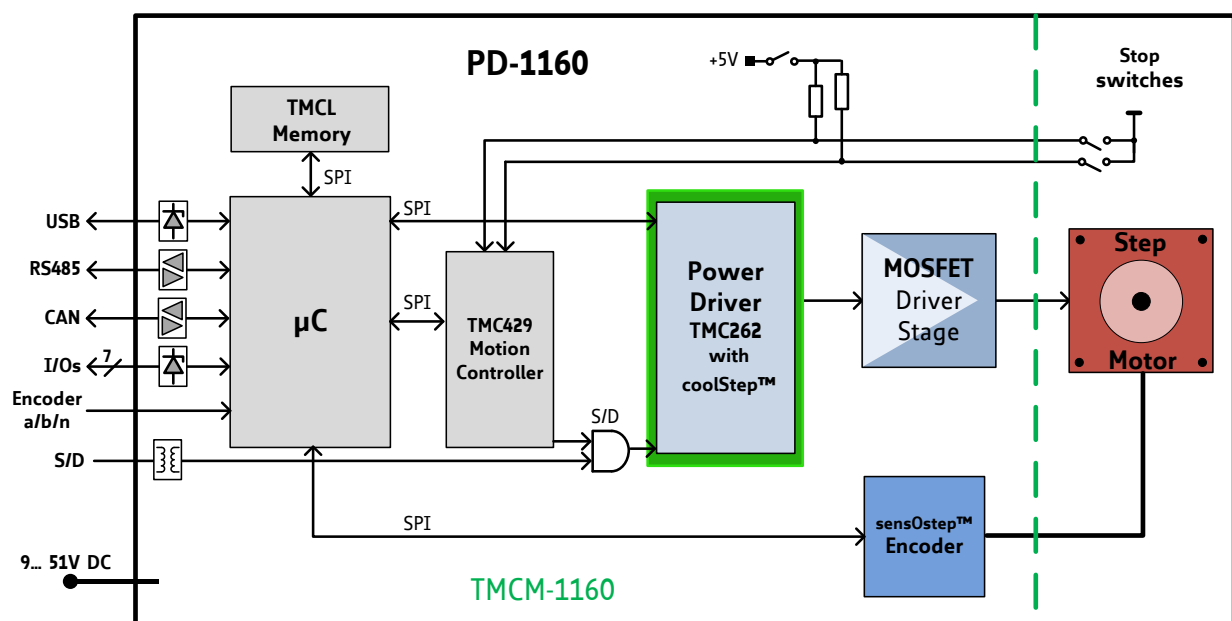

Figure 9.1 Main parts of the PD-1160

The PD-1160 comes with the PC based software development environment TMCL-IDE for the Trinamic Motion Control Language (TMCL). Using predefined TMCL high level commands like *move to position* a rapid and fast development of motion control applications is guaranteed.

Please refer to the PD-1160 Firmware Manual for more information about TMCL commands.

## 10 PD-1160 Operational Description

### 10.1 Calculation: Velocity and Acceleration vs. Microstep and Fullstep Frequency

The values of the parameters sent to the TMC429 do not have typical motor values like rotations per second as velocity. But these values can be calculated from the TMC429 parameters as shown in this section.

#### PARAMETERS OF TMC429

Signal	Description	Range
$f_{CLK}$	clock-frequency	16 MHz
velocity	-	0... 2047
a_max	maximum acceleration	0... 2047
pulse_div	divider for the velocity. The higher the value is, the less is the maximum velocity default value = 0	0... 13
ramp_div	divider for the acceleration. The higher the value is, the less is the maximum acceleration default value = 0	0... 13
Usrs	microstep-resolution (microsteps per fullstep = $2^{Usrs}$ )	0... 8

**Table 10.1 TMC429 velocity parameters**

#### MICROSTEP FREQUENCY

The microstep frequency of the stepper motor is calculated with

$$usf[Hz] = \frac{f_{CLK}[Hz] \cdot velocity}{2^{pulse\_div} \cdot 2048 \cdot 32} \quad \text{with usf: microstep-frequency}$$

#### FULLSTEP FREQUENCY

To calculate the fullstep frequency from the microstep frequency, the microstep frequency must be divided by the number of microsteps per fullstep.

$$fsf[Hz] = \frac{usf[Hz]}{2^{Usrs}} \quad \text{with fsf: fullstep-frequency}$$

The change in the pulse rate per time unit (pulse frequency change per second – the **acceleration a**) is given by

$$a = \frac{f_{CLK}^2 \cdot a_{max}}{2^{pulse\_div+ramp\_div+29}}$$

This results in acceleration in fullsteps of:

$$af = \frac{a}{2^{Usrs}} \quad \text{with af: acceleration in fullsteps}$$

**EXAMPLE:**

Signal	value
f_CLK	16 MHz
velocity	1000
a_max	1000
pulse_div	1
ramp_div	1
usrs	6

$$msf = \frac{16 \text{ MHz} \cdot 1000}{2^1 \cdot 2048 \cdot 32} = \underline{\underline{122070.31 \text{ Hz}}}$$

$$fsf[\text{Hz}] = \frac{122070.31}{2^6} = \underline{\underline{1907.34 \text{ Hz}}}$$

$$a = \frac{(16 \text{ MHz})^2 \cdot 1000}{2^{1+1+29}} = \underline{\underline{119.21 \frac{\text{MHz}}{\text{s}}}}$$

$$af = \frac{119.21 \frac{\text{MHz}}{\text{s}}}{2^6} = \underline{\underline{1.863 \frac{\text{MHz}}{\text{s}}}}$$

**CALCULATION OF THE NUMBER OF ROTATIONS**

A stepper motor has e.g. 72 fullsteps per rotation.

$$RPS = \frac{fsf}{\text{fullsteps per rotation}} = \frac{1907.34}{72} = 26.49$$

$$RPM = \frac{fsf \cdot 60}{\text{fullsteps per rotation}} = \frac{1907.34 \cdot 60}{72} = 1589.46$$



# 11 Life Support Policy

TRINAMIC Motion Control GmbH & Co. KG does not authorize or warrant any of its products for use in life support systems, without the specific written consent of TRINAMIC Motion Control GmbH & Co. KG.

Life support systems are equipment intended to support or sustain life, and whose failure to perform, when properly used in accordance with instructions provided, can be reasonably expected to result in personal injury or death.

© TRINAMIC Motion Control GmbH & Co. KG 2013

Information given in this data sheet is believed to be accurate and reliable. However neither responsibility is assumed for the consequences of its use nor for any infringement of patents or other rights of third parties, which may result from its use.

Specifications are subject to change without notice.

All trademarks used are property of their respective owners.



## 12 Revision History

### 12.1 Document Revision

Version	Date	Author GE - Göran Eggers SD - Sonja Dwersteg	Description
0.91	2012-MAY-03	GE	Initial version
1.00	2012-JUN-12	SD	First complete version including the following chapters: - Reset to factory defaults, - LEDs
1.01	2012-JUL-30	SD	General purpose inputs corrected.
1.02	2013-JUL-23	SD	Chapter 3.2.1 updated.

Table 12.1 Document revision

### 12.2 Hardware Revision

Version	Date	Description
TMCM-1160_V10	2011-JUL-20	Initial version
TMCM-1160_V11	2012-JAN-24	- Inputs IN_0 and IN_1 can be used as analog inputs, also

Table 12.2 Hardware revision

## 13 References

[PD-1160 TMCL]	PD-1160 TMCL Firmware Manual
[TMCL-IDE]	TMCL-IDE User Manual
[QSH5718]	QSH5718 Manual
[QSH6018]	QSH6018 Manual

Please refer to [www.trinamic.com](http://www.trinamic.com).

## X-ON Electronics

Largest Supplier of Electrical and Electronic Components

*Click to view similar products for [Power Management IC Development Tools](#) category:*

*Click to view products by [Analog Devices](#) manufacturer:*

Other Similar products are found below :

[EVB-EP5348UI](#) [MIC23451-AAAYFL EV](#) [MIC5281YMME EV](#) [124352-HMC860LP3E](#) [DA9063-EVAL](#) [ADP122-3.3-EVALZ](#) [ADP130-0.8-EVALZ](#) [ADP130-1.8-EVALZ](#) [ADP1740-1.5-EVALZ](#) [ADP1870-0.3-EVALZ](#) [ADP1874-0.3-EVALZ](#) [ADP199CB-EVALZ](#) [ADP2102-1.25-EVALZ](#) [ADP2102-1.875EVALZ](#) [ADP2102-1.8-EVALZ](#) [ADP2102-2-EVALZ](#) [ADP2102-3-EVALZ](#) [ADP2102-4-EVALZ](#) [AS3606-DB](#) [BQ25010EVM](#) [BQ3055EVM](#) [ISLUSBI2CKIT1Z](#) [LP38512TS-1.8EV](#) [EVAL-ADM1186-1MBZ](#) [EVAL-ADM1186-2MBZ](#) [ADP122UJZ-REDYKIT](#) [ADP166Z-REDYKIT](#) [ADP170-1.8-EVALZ](#) [ADP171-EVALZ](#) [ADP1853-EVALZ](#) [ADP1873-0.3-EVALZ](#) [ADP198CP-EVALZ](#) [ADP2102-1.0-EVALZ](#) [ADP2102-1-EVALZ](#) [ADP2107-1.8-EVALZ](#) [ADP5020CP-EVALZ](#) [CC-ACC-DBMX-51](#) [ATPL230A-EK](#) [MIC23250-S4YMT EV](#) [MIC26603YJL EV](#) [MIC33050-SYHL EV](#) [TPS60100EVM-131](#) [TPS65010EVM-230](#) [TPS71933-28EVM-213](#) [TPS72728YFFEVM-407](#) [TPS79318YEQEVM](#) [UCC28810EVM-002](#) [XILINXPWR-083](#) [LMR22007YMINI-EVM](#) [LP38501ATJ-EV](#)