

PD20-1-1210 Hardware Manual

Hardware Version V1.10 | Document Revision V1.20 • 2019-APR-03

The PANdrive™ PD20-1-1210 is currently our smallest and most compact full mechatronic solution including a NEMA8 / 20mm flange size stepper motor and the TCMC-1210 controller / driver electronics supporting linear and 6-point ramps and RS485 serial interface.

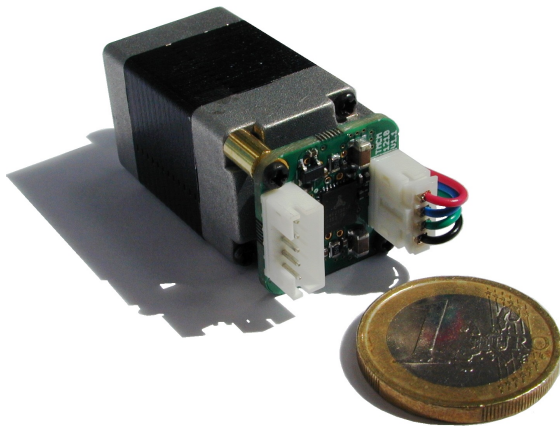

Features

- Stepper Motor NEMA8 / 20mm
- 0.0175Nm holding torque
- with controller/driver
- Linear and sixPoint™ ramps
- +6...30V DC supply voltage
- Up to 0.6A RMS motor current
- RS485 interface
- integrated simple hall-sensor based encoder
- 1x multi-purpose input

Applications

- | | | |
|--------------------------|----------------------|-------------------|
| • Laboratory Automation | • Robotics | • Life Science |
| • Manufacturing | • Factory Automation | • Biotechnology |
| • Semiconductor Handling | • Test & Measurement | • Liquid Handling |

Simplified Block Diagram

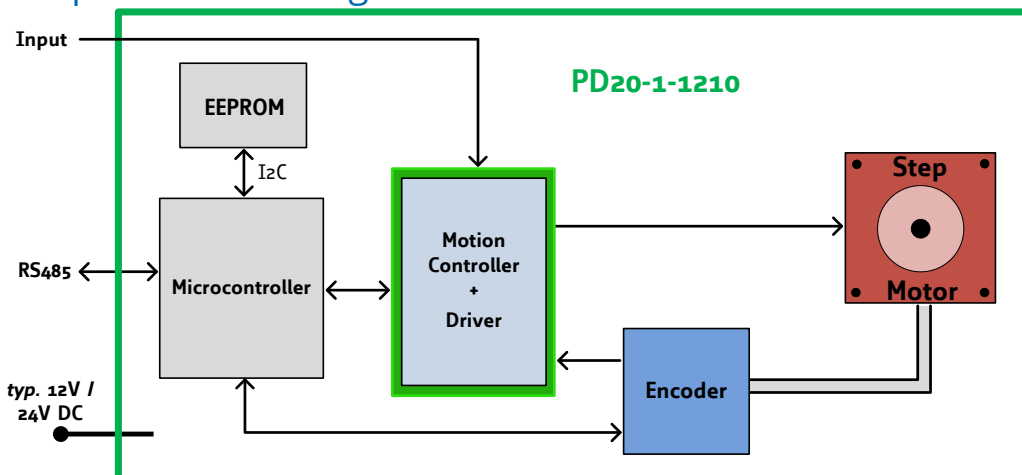

Contents

1	Features	3
2	Order Codes	4
3	Mechanical and Electrical Interfacing	5
3.1	Dimensions of PD20-1-1210	5
3.2	Stepper motor	6
4	Connectors	7
4.1	Power, RS485 and HOME connector	8
4.2	Motor Connector	8
5	On-Board LED	10
6	Reset to Factory Defaults	10
7	I/Os	11
7.1	Digital input IN0	11
8	Communication	12
8.1	RS485	12
9	Motor driver current	13
10	Torque curves	16
10.1	PD20-1-1210 Torque Curve	16
11	Functional Description	17
12	Operational Ratings and Characteristics	18
13	Abbreviations used in this Manual	19
14	Figures Index	20
15	Tables Index	21
16	Supplemental Directives	22
16.1	Producer Information	22
16.2	Copyright	22
16.3	Trademark Designations and Symbols	22
16.4	Target User	22
16.5	Disclaimer: Life Support Systems	22
16.6	Disclaimer: Intended Use	22
16.7	Collateral Documents & Tools	23
17	Revision History	24
17.1	Hardware Revision	24
17.2	Document Revision	24



1 Features

The PANdrive™ PD20-1-1210 is currently our smallest and most compact full mechatronic solution including a NEMA8 / 20mm flange size stepper motor, the TMCM-1210 controller / driver electronics and hall sensor based encoder. It can be controlled via RS485 and offers one digital input for easy homing / initial search for reference position.

Motion Controller

- Motion profile calculation in real-time
- On the fly alteration of motor parameters (e.g. position, velocity, acceleration)
- Linear and unique sixPoint™ ramp in hardware
- Reference / end switch input

Driver

- Motor current: up to 0.6A RMS (1A peak, programmable in software)
- Supply voltage: +12V or +24V DC (+6... +30V DC)
- 256 microsteps per fullstep
- SpreadCycle™ highly dynamic current control chopper
- StealthChop™ for quiet operation and smooth motion

Position sensor

- integrated hall sensor based absolute position (within one rotation) magnetic encoder (resolution: 4096 increments per rotation) - suitable for low velocity applications (up-to few hundred rpm) - e.g. initial reference search (together with HOME sensor) after power-up.

Interfaces

- RS485 interface
- 1 digital input, can be used as reference switch (HOME) or left / right (STOP_L, STOP_R) stop switch input

Software

- TMCL™ remote (direct mode) and standalone operation (memory for up to 876 TMCL™ commands), fully supported by TMCL-IDE (PC based integrated development environment). Please see PD20-1-1210 TMCL firmware manual for more details



2 Order Codes

The combination of motor and motor mounted controller/driver electronic is currently available:

The length of the PANdrives is specified without the length of the axis. For the overall length of the product please add 15mm

Order Code	Description	Size (LxWxH)
PD20-1-1210	PANdrive™ with NEMA8 stepper motor, 0.0175Nm max. TMCM-1210 electronics, 0.6A RMS, +24V, RS485, hall sensor based magnetic encoder, TMCL firmware	20mm x 20mm x 46mm

Table 1: Order Code

A cable loom set is available for this module:

Order Code	Description
TMCM-1210-CABLE	Cable loom for TMCM-1210: <ul style="list-style-type: none"> • 1x cable loom for power supply, RS485 and digital input connector (cable length 200mm, 5pin JST PH connector at one end, open wires at the other end) • 1x cable loom for motor connector (cable length 200mm, 4pin JST PH connector at one end, open wires at the other end)

Table 2: TMCM-1210 Cable Loom

The TMCM-1210 controller/driver electronics is also available separately. Please refer to TMCM-1210 hardware manual for further details.



3 Mechanical and Electrical Interfacing

The PD20-1-1210 consists of the QSH2018-33-06-002 NEMA8 / 20mm stepper motor with 0.6A RMS rated coil current and 17.5mNm holding torque, the TCMC-1210 controller / driver electronic for up-to 0.6A RMS motor coil current mounted on the backside of the motor and an integrated hall sensor based magnetic encoder. Please see also the TCMC-1210 hardware and firmware manuals for more details.

NOTICE	Note: In order to make proper use of the integrated hall sensor based magnetic encoder (the sensor IC is placed on the bottom of the pcb) the TCMC-1210 electronics should not be removed/moved relative to the motor. In case the integrated encoder feature is not used, the electronics may be moved or even removed from the motor and placed somewhere else according to application requirements.
---------------	--

3.1 Dimensions of PD20-1-1210

The overall length of the NEMA8 / 20mm flange size stepper motor and the TCMC-1210 electronics mounted to the backside of the motor is about 46mm without motor shaft and without mating connectors / cable loom.

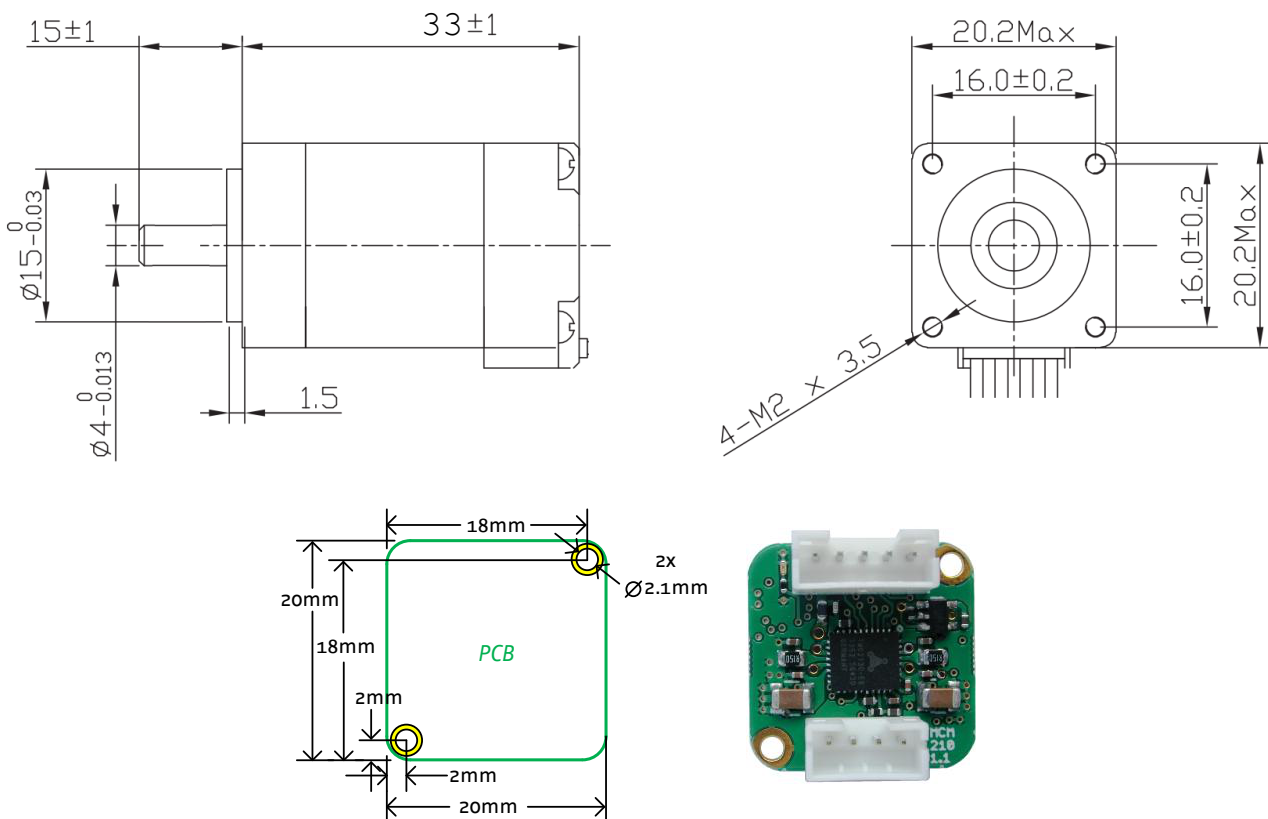

Figure 1: PD20-1-1210 with NEMA8 / 20mm stepper motors (all dimensions in mm)



3.2 Stepper motor

Main characteristics of the motor available as part of the PANdrive™:

Specifications	Unit	PD20-1-1210
Step angle	°	1.8
Step angle accuracy	%	+/-5
Ambient temperature	°C	-20...+50
Max. motor temperature	°C	80
Shaft radial play (450g load)	mm	0.02
Shaft axial play (450g load)	mm	0.08
Max radial force (20mm from front flange)	N	20
Max axial force	N	2
Rated voltage	V	3.96
Rated phase current	A	0.6
Phase resistance at 20°C	Ω	6.5
Phase inductance (typ.)	mH	1.7
Holding torque	Nm	0.0175
Insulation class		B
Rotor inertia	g cm ²	2
Weight	kg	0.06

Table 3: NEMA8 / 20mm stepper motor technical data



4 Connectors

The PD20-1-1210 offers two connectors including the motor connector which is used for connecting the motor coils to the electronics. The other five pin connector combines power supply input, RS485 2-wire communication interface and one digital input which can be used as general purpose digital input but, also as end or reference switch input for the motin controller.

NOTICE

Start with power supply OFF and do not connect or disconnect motor during operation! Motor cable and motor inductivity might lead to voltage spikes when the motor is (dis)connected while energized. These voltage spikes might exceed voltage limits of the driver MOSFETs and might permanently damage them. Therefore, always switch off / disconnect power supply or at least disable driver stage before connecting / disconnecting motor.

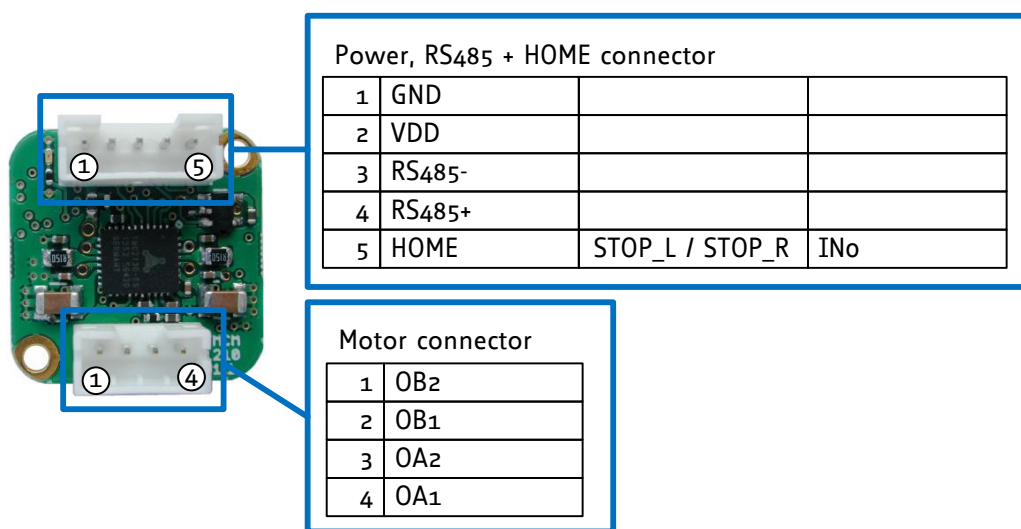

Figure 2: PD20-1-1210 connectors

Connector Types and Mating Connectors		
Connector	Connector type on-board	Mating connector type
Power, RS485 and HOME	JST B5B-PH-K-S (JST PH series, 5pins, 2mm pitch)	Connector housing: JST PHR-5 Contacts: JST SPH-002T-P0.5S Wire: 0.22mm ² , AWG 24
Motor	JST B4B-PH-K-S (JST PH series, 4pins, 2mm pitch)	Connector housing: JST PHR-4 Contacts: JST SPH-002T-P0.5S Wire: 0.22mm ² , AWG 24

Table 4: Connector Types and Mating Connectors of the PD20-1-1210



4.1 Power, RS485 and HOME connector

The PD20-1-1210 offers one 5pin JST PH series combined connector for power supply input, RS485 2-wire serial communication and one digital input. The digital input might be used either as general purpose input or as stop switch (STOP_L or STOP_R) or HOME switch input.

Power, RS485 and HOME Connector Pin Assignment			
Pin	Label	Direction	Description
1	GND	Power (GND)	Common system supply and signal ground
2	V _{DD}	Power (input)	Main power supply input for the driver and on-board logic 6...30V
3	RS485-	Bidirectional	RS485 interface, diff. signal (inverting)
4	RS485+	Bidirectional	RS485 interface, diff. signal (non-inverting)
5	IN0	Input	General purpose, STOP_L, STOP_R or HOME input.

Table 5: Power, RS485 and HOME Connector pin assignment

NOTICE

Do not connect or disconnect motor during operation! Motor cable and motor inductivity might lead to voltage spikes when the motor is (dis)connected while energized. These voltage spikes might exceed voltage limits of the driver MOSFETs and might permanently damage them. Therefore, always switch off / disconnect power supply or at least disable driver stage before connecting / disconnecting motor.

NOTICE

Take care of polarity, wrong polarity can destroy the board!

4.2 Motor Connector

A second 4pin JST PH series connector is available for connection of a 2-phase bipolar stepper motor.

Motor Connector Pin Assignment			
Pin	Label	Direction	Description
1	B2	out	Pin 2 of motor coil B
2	B1	out	Pin 1 of motor coil B
3	A2	out	Pin 2 of motor coil A
4	A1	out	Pin 1 of motor coil A

Table 6: Motor Connector Pin Assignment



NOTICE

Do not connect or disconnect motor during operation! Motor cable and motor inductivity might lead to voltage spikes when the motor is (dis)connected while energized. These voltage spikes might exceed voltage limits of the driver MOSFETs and might permanently damage them. Therefore, always switch off / disconnect power supply or at least disable driver stage before connecting / disconnecting motor.



5 On-Board LED

The board offers one LED in order to indicate board status. The function of this LED depends on the firmware version. With standard TMCL firmware the green LED should be flashing slowly during operation. When there is no valid firmware programmed into the board or during firmware update the green LED will be permanently switched on. During reset to factory default values the green LED will be flashing fast.

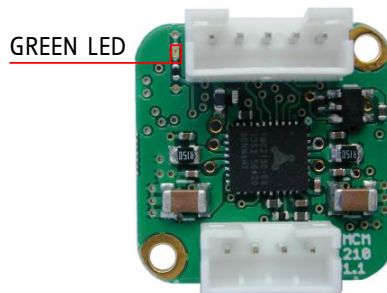

Figure 3: PD20-1-1210 LED

6 Reset to Factory Defaults

It is possible to reset all settings in firmware for the PD20-1-1210 to factory defaults without establishing a working communication connection. This might be helpful in case communication parameters of the preferred interface have been set to unknown values or got lost.

For this procedure two pads on the bottom side of the module (electronics) have to be shorted (electrically connected with each other) during power-on.

Please perform the following steps:

1. Switch power supply OFF (and disconnect USB cable if applicable)
2. Short CLK and DIO pads of programming pads on bottom of pcb (see figure 4)
3. Switch power supply ON again (or connect USB again if applicable)
4. Wait until the on-board red and green LEDs start flashing fast (this might take a while)
5. Switch power supply OFF again (and disconnect USB cable if applicable)
6. Remove short between pads
7. After switching power supply ON again (and / or connecting USB cable) all permanent settings have been restored to factory defaults

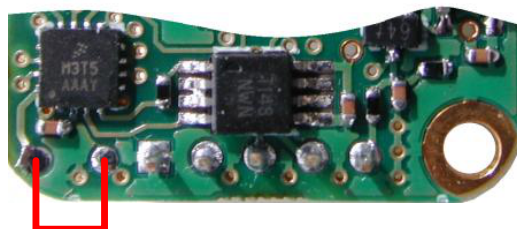

Figure 4: Reset to factory default settings



7 I/Os

The PD20-1-1210 offers one digital input which is part of the power supply input, RS485 serial interface and digital input connector.

7.1 Digital input IN0

The PD20-1-1210 offers one digital input IN0 which accept signals between 0 and 30V with voltages above approx. 4.6V recognized as logical '1' and below 2V as logical '0'. This input maybe used either as general purpose digital input IN0, end switch input (connected to motion controller) for left or right stop switch (STOP_L or STOP_R) or as HOME switch input (for initial homing / reference search).

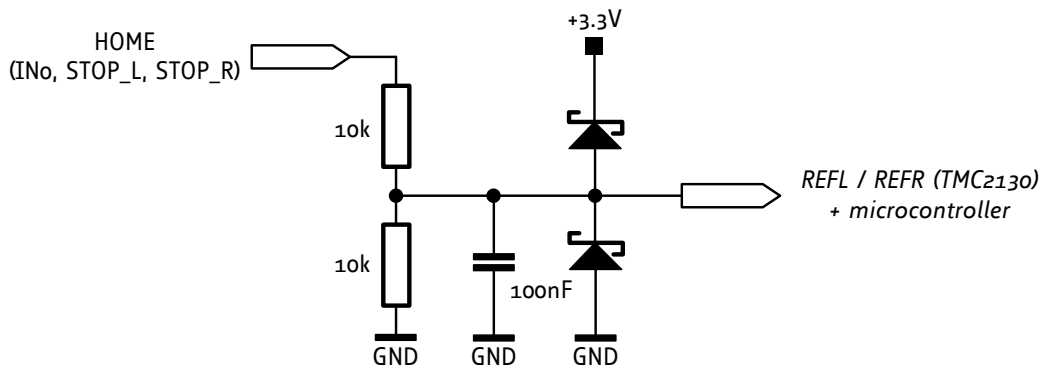

Figure 5: Digital input IN0 - simplified schematic extract



8 Communication

8.1 RS485

For remote control and communication with a host system the PD20-1-1210 provides a two wire RS485 bus interface. For proper operation the following items should be taken into account when setting up an RS485 network:

1. **BUS STRUCTURE:**

The network topology should follow a bus structure as closely as possible. That is, the connection between each node and the bus itself should be as short as possible. Basically, it should be short compared to the length of the bus.

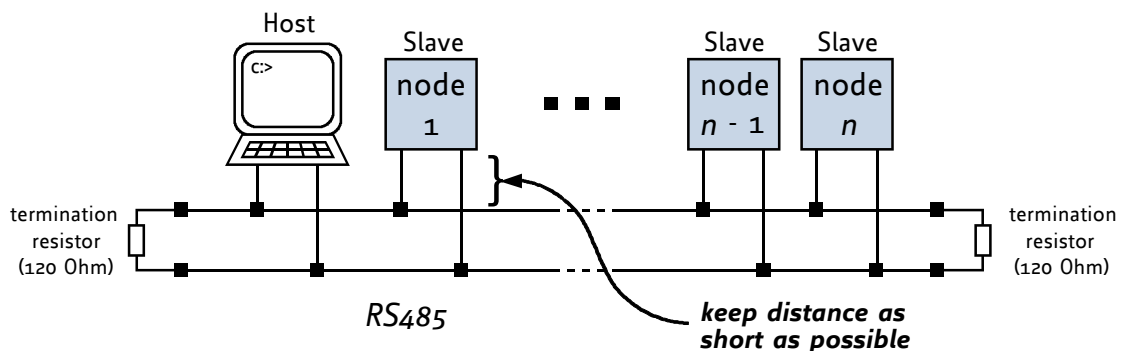

Figure 6: RS485 bus structure with termination resistors

2. **BUS TERMINATION:**

Especially for longer busses and/or multiple nodes connected to the bus and/or high communication speeds, the bus should be properly terminated at both ends. The PD20-1-1210 does not integrate any termination resistor. Therefore, 120 Ohm termination resistors at both ends of the bus have to be added externally.

3. **NUMBER OF NODES:**

The RS485 electrical interface standard (EIA-485) allows up to 32 nodes to be connected to a single bus. The bus transceiver used on the PD20-1-1210 units (SN65HVD3085E) offers a significantly reduced bus load compared to the standard and allows a maximum of 255 units to be connected to a single RS485 bus using standard TMCL firmware. *Please note: usually it cannot be expected to get reliable communication with the maximum number of nodes connected to one bus and maximum supported communication speed at the same time. Instead, a compromise has to be found between bus cable length, communication speed and number of nodes.*

4. **COMMUNICATION SPEED:**

The maximum RS485 communication speed supported by the PD20-1-1210 hardware is 1Mbit/s. Factory default is 9600 bit/s. Please see separate PD20-1-1210 TMCL firmware manual for information regarding other possible communication speeds below the upper hardware limit.

5. **NO FLOATING BUS LINES:**

Avoid floating bus lines while neither the host/master nor one of the slaves along the bus line is transmitting data (all bus nodes switched to receive mode). Floating bus lines may lead to communication errors. In order to ensure valid signals on the bus it is recommended to use a resistor network connecting both bus lines to well defined logic levels.

There are actually two options which can be recommended: Add resistor (bias) network on one side of the bus, only (120R termination resistor still at both ends):



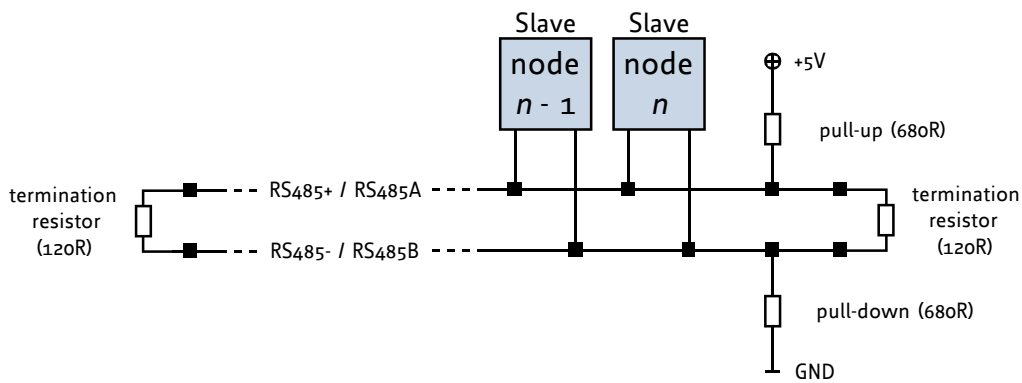

Figure 7: RS485 bus lines with resistor (bias) network on one side, only

Or add resistor network at both ends of the bus (like Profibus™ termination):

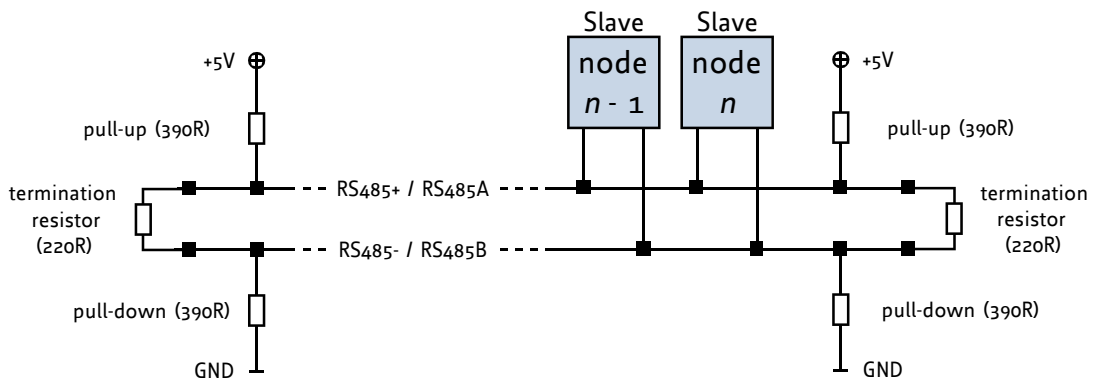

Figure 8: RS485 bus lines with Profibus™ recommended line termination

9 Motor driver current

The on-board stepper motor driver operates current controlled. The driver current may be programmed in software with 32 effective scaling steps in hardware.

Explanation of different columns in table below:

Motor current setting in software (TMCL)

These are the values for TMCL axis parameter 6 (motor run current) and 7 (motor standby current). They are used to set the run / standby current using the following TMCL commands:

SAP 6, 0, <value> // set run current

SAP 7, 0, <value> // set standby current

(read-out value with GAP instead of SAP. Please see separate PD20-1-1210 firmware manual for further information)

Motor current I_{RMS} [A]

Resulting motor current based on motor current setting



Motor current setting in software (TMCL)	Motor current I_{COIL} [A] peak	Motor current I_{COIL} [A] RMS
0...7	0.06	0.04
8...15	0.08	0.06
16...23	0.10	0.07
24...31	0.13	0.09
32...39	0.15	0.11
40...47	0.18	0.13
48...55	0.21	0.15
56...63	0.24	0.17
64...71	0.26	0.19
72...79	0.29	0.21
80...87	0.32	0.23
88...95	0.35	0.25
96...103	0.38	0.27
104...111	0.41	0.29
112...119	0.43	0.30
120...127	0.46	0.32
128...135	0.49	0.34
136...143	0.51	0.36
144...151	0.54	0.38
152...159	0.56	0.40
160...167	0.59	0.42
168...175	0.62	0.44
176...183	0.64	0.45
184...191	0.67	0.47
192...199	0.70	0.49
200...207	0.72	0.51
208...215	0.75	0.53
216...223	0.77	0.55
224...231	0.80	0.57
232...239	0.82	0.58
240...247	0.84	0.60
248...255	0.87	0.62

Table 8: Available motor current settings



In addition to the settings in the table the motor current may be switched off completely (free-wheeling) using axis parameter 204 (see PD20-1-1210 firmware manual).



10 Torque curves

10.1 PD20-1-1210 Torque Curve

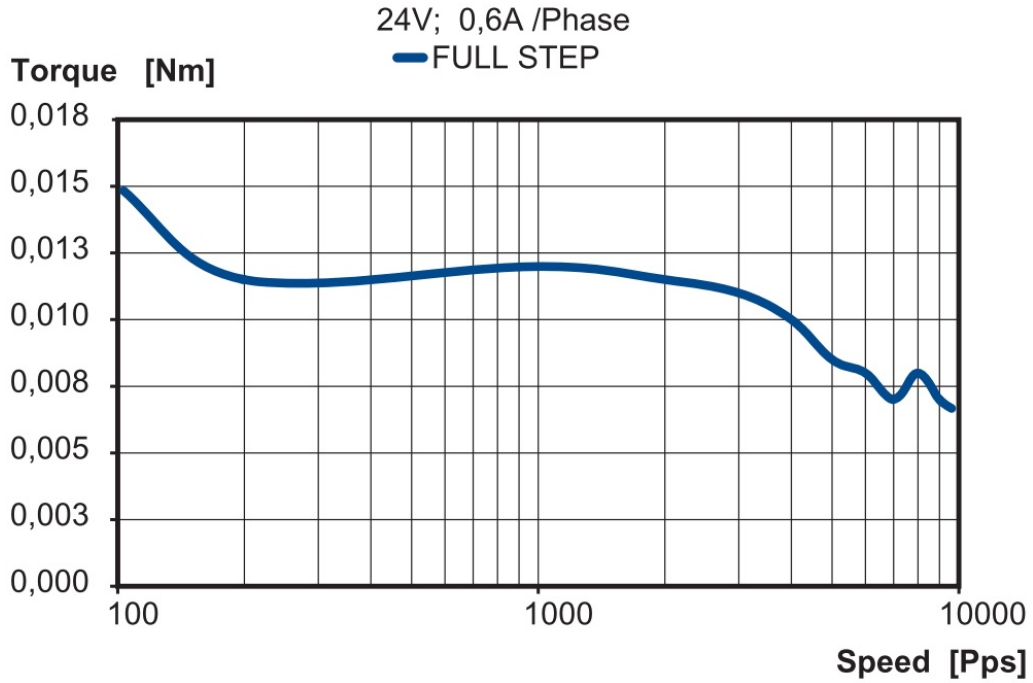

Figure 9: PD20-1-1210 torque vs. velocity 24V / 0.6A RMS



11 Functional Description

The PD20-1-1210 is a full mechatronic solution including a 20mm flange (NEMA8) bipolar stepper motor and the TCMC-1210 controller / driver electronics.

The PD20-1-1210 can be controlled via RS485 serial interfaces. There is one general purpose digital inputs which can be used, also as STOP_L / STOP_R or HOME switch input (for reference movements, as end switches etc. depending on firmware, mode and configuration).

The PD20-1-1210 with TMCL™ firmware option is supported by the PC based software development environment TMCL-IDE for the Trinamic Motion Control Language (TMCL™). Using predefined TMCL™ high level commands like move to position a rapid and fast development of motion control applications is guaranteed. Please refer to the PD20-1-1210 firmware manual for more information about TMCL™ commands.

Communication traffic is kept low since all time critical operations, e.g. ramp calculation are performed on board. Complete stand-alone or full remote control or anything in-between is possible. The firmware of the module can be updated via the serial interface.

The PD20-1-1210 contains the following main components:

- microprocessor, which runs the TMCL operating system (connected to TMCL memory)
- motion controller which calculates ramps and speed profiles internally in hardware
- driver with StallGuard2™ and its energy efficient CoolStep™ feature and StealthChop™ for extremely quiet operation
- hall sensor based encoder which delivers position feedback at low speed (few 100rpm max.) - can be used for reference search e.g. after power-up

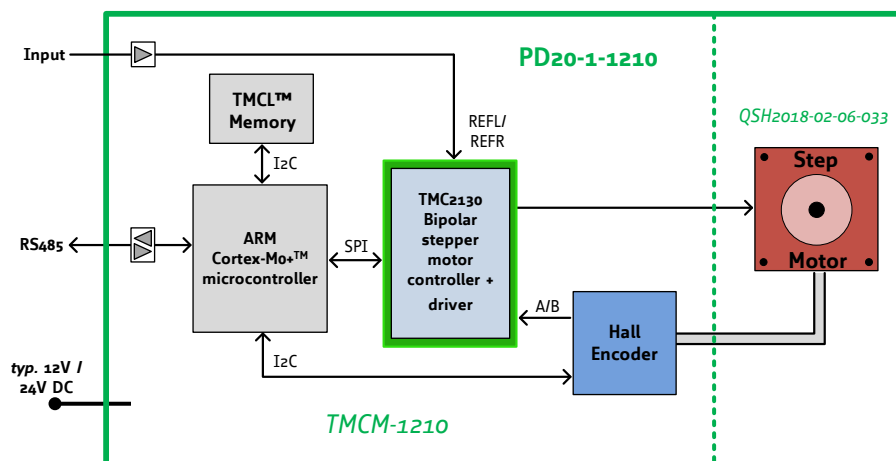

Figure 10: PD20-1-1210 block diagram



12 Operational Ratings and Characteristics

NOTICE

Never Exceed the absolute maximum ratings! Keep the power supply voltage below the upper limit of +30V! Otherwise the board electronics will seriously be damaged! Especially, when the selected operating voltage is near the upper limit a regulated power supply is highly recommended.

General Operational Ratings					
Symbol	Parameter	Min	Typ	Max	Unit
V_{DD}	Power supply voltage	6	12...24	30	V
I_{DD}	Power supply current		$\ll I_{COIL_RMS}$	$1.4 \times I_{COIL_RMS}$	A
I_{COIL_PEAK}	Motor coil current for sine wave peak (chopper regulated, adjustable via software)	0		0.9	A
I_{COIL_RMS}	Continuous motor current (RMS)	0		0.6	A
T_{ENV}	Environmental temperature at rated current (no forced cooling required)	-20		40	°C

Table 9: General operational ratings of the PD20-1-1210

Operational Ratings of the HOME switch input					
Symbol	Parameter	Min	Typ	Max	Unit
V_{HOME}	Input voltage for HOME/STOP_L/STOP_R/IN0	0		+30	V
V_{HOME_L}	Low level voltage for HOME/STOP_L/STOP_R/IN0	0		2	V
V_{HOME_R}	High level voltage for HOME/STOP_L/STOP_R/IN0	4.6		+30	V

Table 10: Operational ratings of HOME + STOP switches / IN0 input

Operational Ratings of the RS485 Interface					
Symbol	Parameter	Min	Typ	Max	Unit
N_{RS485}	Number of nodes connected to single RS485 network			255	
f_{RS485}	Max. speed for RS485 network			1Mbit/s	

Table 11: Operational ratings of the RS485 interface

Please note: 1Mbit/s is the hardware limit for the on-board RS485 transceiver.



13 Abbreviations used in this Manual

Abbreviation	Description
IDE	Integrated Development Environment
LED	Light Emmitting Diode
RMS	Root Mean Square value
TMCL	TRINAMIC Motion Control Language

Table 12: Abbreviations used in this Manual



14 Figures Index

1	PD20-1-1210 with NEMA8 / 20mm stepper motors (all dimensions in mm)	5	7	RS485 bus lines with resistor (bias) network on one side, only	13
2	PD20-1-1210 connectors	7	8	RS485 bus lines with Profibus™recommended line termination	13
3	PD20-1-1210 LED	10	9	PD20-1-1210 torque vs. velocity 24V / 0.6A RMS	16
4	Reset to factory default settings	10	10	PD20-1-1210 block diagram	17
5	Digital input IN0 - simplified schematic extract	11			
6	RS485 bus structure with termination resistors	12			



15 Tables Index

1	Order Code	4	9	General operational ratings of the PD20-1-1210	18
2	TMCM-1210 Cable Loom	4	10	Operational ratings of HOME + STOP switches / IN0 input	18
3	NEMA8 / 20mm stepper motor technical data	6	11	Operational ratings of the RS485 interface	18
4	Connector Types and Mating Connectors of the PD20-1-1210	7	12	Abbreviations used in this Manual	19
5	Power, RS485 and HOME Connector pin assignment	8	13	Hardware Revision	24
6	Motor Connector Pin Assignment	8	14	Document Revision	24
8	Available motor current settings	14			



16 Supplemental Directives

16.1 Producer Information

16.2 Copyright

TRINAMIC owns the content of this user manual in its entirety, including but not limited to pictures, logos, trademarks, and resources. © Copyright 2019 TRINAMIC. All rights reserved. Electronically published by TRINAMIC, Germany.

Redistributions of source or derived format (for example, Portable Document Format or Hypertext Markup Language) must retain the above copyright notice, and the complete Datasheet User Manual documentation of this product including associated Application Notes; and a reference to other available product-related documentation.

16.3 Trademark Designations and Symbols

Trademark designations and symbols used in this documentation indicate that a product or feature is owned and registered as trademark and/or patent either by TRINAMIC or by other manufacturers, whose products are used or referred to in combination with TRINAMIC's products and TRINAMIC's product documentation.

This Hardware Manual is a non-commercial publication that seeks to provide concise scientific and technical user information to the target user. Thus, trademark designations and symbols are only entered in the Short Spec of this document that introduces the product at a quick glance. The trademark designation /symbol is also entered when the product or feature name occurs for the first time in the document. All trademarks and brand names used are property of their respective owners.

16.4 Target User

The documentation provided here, is for programmers and engineers only, who are equipped with the necessary skills and have been trained to work with this type of product.

The Target User knows how to responsibly make use of this product without causing harm to himself or others, and without causing damage to systems or devices, in which the user incorporates the product.

16.5 Disclaimer: Life Support Systems

TRINAMIC Motion Control GmbH & Co. KG does not authorize or warrant any of its products for use in life support systems, without the specific written consent of TRINAMIC Motion Control GmbH & Co. KG.

Life support systems are equipment intended to support or sustain life, and whose failure to perform, when properly used in accordance with instructions provided, can be reasonably expected to result in personal injury or death.

Information given in this document is believed to be accurate and reliable. However, no responsibility is assumed for the consequences of its use nor for any infringement of patents or other rights of third parties which may result from its use. Specifications are subject to change without notice.

16.6 Disclaimer: Intended Use

The data specified in this user manual is intended solely for the purpose of product description. No representations or warranties, either express or implied, of merchantability, fitness for a particular purpose



or of any other nature are made hereunder with respect to information/specification or the products to which information refers and no guarantee with respect to compliance to the intended use is given.

In particular, this also applies to the stated possible applications or areas of applications of the product. TRINAMIC products are not designed for and must not be used in connection with any applications where the failure of such products would reasonably be expected to result in significant personal injury or death (safety-Critical Applications) without TRINAMIC's specific written consent.

TRINAMIC products are not designed nor intended for use in military or aerospace applications or environments or in automotive applications unless specifically designated for such use by TRINAMIC. TRINAMIC conveys no patent, copyright, mask work right or other trade mark right to this product. TRINAMIC assumes no liability for any patent and/or other trade mark rights of a third party resulting from processing or handling of the product and/or any other use of the product.

16.7 Collateral Documents & Tools

This product documentation is related and/or associated with additional tool kits, firmware and other items, as provided on the product page at: www.trinamic.com.



17 Revision History

17.1 Hardware Revision

Version	Date	Author	Description
TMCM-1210_V10	2014-DEC-17	GE	Initial version.
TMCM-1210_V11	2015-JUN-25	GE	Several corrections, added features and circuit optimization
PD20-1-1210	2019-MAR-12	GE	PANdrive based on TMCM-1210_V11 and NEMA8 / 20mm flange size stepper motor

Table 13: Hardware Revision

17.2 Document Revision

Version	Date	Author	Description
1.00	2018-JUN-18	GE	Initial version based on TMCM-1210 hardware manual
1.10	2019-MAR-14	GE	Update for series version
1.20	2019-APR-03	GE	Minor corrections

Table 14: Document Revision



X-ON Electronics

Largest Supplier of Electrical and Electronic Components

Click to view similar products for [Stepper Motors](#) category:

Click to view products by [Analog Devices](#) manufacturer:

Other Similar products are found below :

[HT17-275](#) [5014-020](#) [HT17-271D](#) [82924041](#) [82924036](#) [82914016](#) [80910502](#) [80910501](#) [80910003](#) [HT23-598](#) [HT08-221](#) [902-0135-000](#)
[MS11HS3P4067-09RL](#) [MS17HD6P4200-24RL](#) [MS11HS5P4150-13RL](#) [MS08HY1P4050-09RL](#) [MS08HY3P4050-02RL](#) [ML24HCAL3550-01RL](#) [MS17HD6P4100-16RL](#) [ML23HS8P4220-16RL](#) [MS17HD2P4200-20RL](#) [ML23HSAL4500-E](#) [MS14HS5P4100-03RL](#) [MS17HD2P4100-27RL](#) [MS14HS1P4100-09RL](#) [MS11HS1P4100-25RL](#) [ML23HSAP4300-18RL](#) [ML23HS4P4100-02RL](#) [PL23HS8L4550-05RL](#)
[PL23HSAL4500-05RL](#) [MS17HD4P4150-22RL](#) [PM42S-048-HHC8](#) [PM20L-020-HHC3](#) [PM42L-048-HHC9](#) [82930002](#) [HT34-504](#) [82910003](#)
[103H7823-0440](#) [103H7126-0440](#) [103H8223-5141](#) [103H8223-6340](#) [103H7126-0740](#) [103H7126-5740](#) [103H7822-5740](#) [STEPPER MOTOR BIPOLAR 42X38MM 2.8V 1.7A](#) [SY20STH30-0604A](#) [STEPPER MOTOR: UNIPOLAR/BIPOLAR 57Å—56MM](#) [ROB-10551](#) [STEPPER MOTOR: UNIPOLAR/BIPOLAR 57Å—76MM](#) [103H7123-5740](#)