

PD42-1070 Hardware Manual

Hardware Version V1.00 | Document Revision V1.20 • 2019-01-24

PD42-1070 is an easy to use PANdrive™ smart stepper motor. The module is controlled via a step and direction interface. One configuration pin selects the current control mode between stealthChop™ for absolute silent motor control and spreadCycle™ for high speed. A TTL UART interface allows for more advanced configuration, for example of the stallGuard2™ and coolStep™ features, and permanent parameter storage via TMCL™-IDE.



Features

- Supply Voltage +9 to +24V DC
- Step and direction interface
- **microPlyer™** to 256 μ -steps
- **stealthChop™** silent PWM mode
- **spreadCycle™** smart mixed decay
- **stallGuard2™** load detection
- **coolStep™** autom. current scaling
- UART configuration interface

Applications

- Lab-Automation
- Robotics
- CNC
- Manufacturing
- Factory Automation
- Laboratory Automation

Simplified Block Diagram

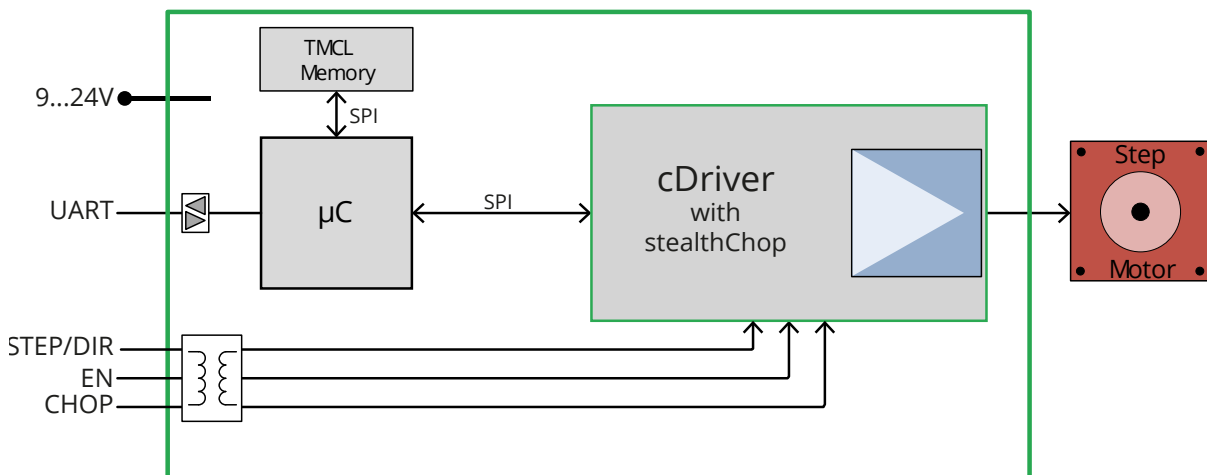

Contents

1	Features	3
1.1	General Features	3
1.2	TRINAMIC's Unique Features	4
1.2.1	stealthChop™	4
1.2.2	spreadCycle™	4
1.3	stallGuard2	5
1.4	coolStep	5
2	Order Codes	6
3	Mechanical and Electrical Interfacing	7
3.1	PD42-1070 Dimensions and Weight	7
3.2	PD42-1070 Motor Parameters	8
3.3	PD42-1070 Torque Curves	9
4	Connectors and LEDs	11
4.1	Motor Connector	11
4.2	I/O Connector	12
4.3	TTL UART Connection	13
4.4	Status LEDs	13
5	Functional Description	14
5.1	Typical Application Wiring	14
5.2	Optically Isolated Inputs with Common Anode Input	14
5.3	Optically Isolated Inputs with Common Cathode Input	16
5.4	Thermal Behavior	17
6	Operational Ratings and Characteristics	18
6.1	Absolute Maximum Ratings	18
6.2	Electrical Characteristics (Ambient Temperature 25° C)	18
6.3	I/O Ratings (Ambient Temperature 25° C)	18
6.4	Functional Characteristics	19
6.5	Other Requirements	19
7	Abbreviations used in this Manual	20
8	Figures Index	21
9	Tables Index	22
10	Supplemental Directives	23
10.1	Producer Information	23
10.2	Copyright	23
10.3	Trademark Designations and Symbols	23
10.4	Target User	23
10.5	Disclaimer: Life Support Systems	23
10.6	Disclaimer: Intended Use	23
10.7	Collateral Documents & Tools	24
11	Revision History	25
11.1	Hardware Revision	25
11.2	Document Revision	25



1 Features

The PANdrive™ PD42-1070 is a full mechatronic solution with state of the art feature set. It is highly integrated and offers a convenient handling.

The PD42-1070 includes a stepper motor and driver electronics. It can be used in many decentralized applications and has been designed for 0.20...0.47 Nm max. holding torque and 24V DC nominal supply voltage. With stealthChop™, the PD42-1070 offers absolutely silent and smooth motor operation for lower and medium velocities. With spreadCycle™, the PD42-1070 offers a high performance current controlled chopper mode for highest velocities with perfect zero crossing performance. With stallGuard2™, a sensorless load detection feature is provided, which is required for using the automatic current scaling feature coolStep™. The PD42-1070 can be used with a simple step and direction interface and can be configured using a TTL UART interface.

stallGuard2 and coolStep must be configured via TTL UART interface and are disabled by default.

1.1 General Features

Main Characteristics

- Supply Voltage +9V to +24V DC
- 1.0A RMS phase current (ca. 1.4A peak phase current)
- Highest micro step resolution, up to 256 micro steps per full step
- microPlyer™ microstep interpolator for obtaining increased smoothness of microstepping over a low frequency STEP/DIR interface
- With housing and motor mounted
- Permanent onboard parameter storage
- Simple step & direction mode
- Noiseless stealthChop™ chopper mode for slow to medium velocities
- High performance spreadCycle™ chopper mode
- High-precision sensorless load measurement with stallGuard2™
- Automatic current scaling algorithm coolStep™ to save energy and keep your drive cool

Optically Isolated Inputs

- Step & direction interface with up to 45kHz input frequency
- Enable input to power-on/-off driver H-bridges
- Mode select input to switch between the two chopper modes

TTL UART Interface

- TTL-level UART interface for parameter configuration
- Interface speed 9600-115200 bps (default 9600 bps)
- TMCL-based protocol for online configuration and permanent parameter settings
- Bootloader for firmware updates



1.2 TRINAMIC's Unique Features

1.2.1 stealthChop™

stealthChop is an extremely quiet mode of operation for low and medium velocities. It is based on a voltage mode PWM. During standstill and at low velocities, the motor is absolutely noiseless. Thus, stealthChop operated stepper motor applications are very suitable for indoor or home use. The motor operates absolutely free of vibration at low velocities. With stealthChop, the motor current is applied by driving a certain effective voltage into the coil, using a voltage mode PWM. There are no more configurations required except for the regulation of the PWM voltage to yield the motor target current.

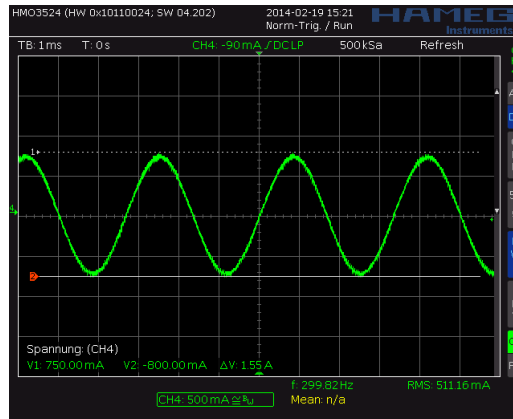

Figure 1: Motor coil sine wave current using stealthChop (measured with current probe)

1.2.2 spreadCycle™

The spreadCycle chopper is a high-precision, hysteresis-based, and simple to use chopper mode, which automatically determines the optimum length for the fast-decay phase. Several parameters are available to optimize the chopper to the application. spreadCycle offers optimal zero crossing performance compared to other current controlled chopper algorithms and thereby allows for highest smoothness. The true target current is powered into the motor coils.

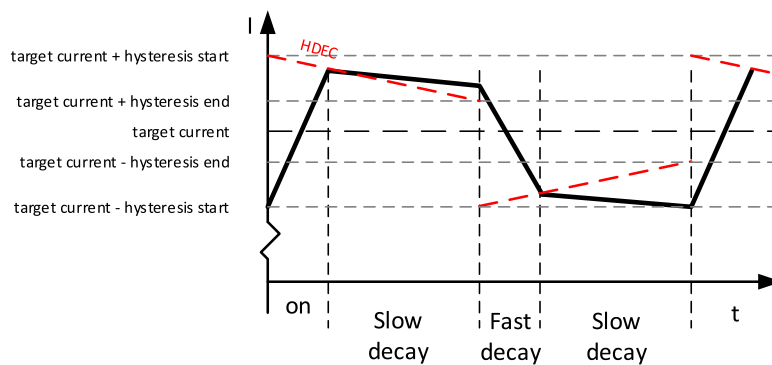

Figure 2: spreadCycle principle



1.3 stallGuard2

stallGuard2 is a high-precision sensorless load measurement using the back EMF of the motor coils. It can be used for stall detection as well as other uses at loads below those which stall the motor. The stallGuard2 measurement value changes linearly over a wide range of load, velocity, and current settings. At maximum motor load, the value reaches zero or is near zero. This is the most energy-efficient point of operation for the motor.

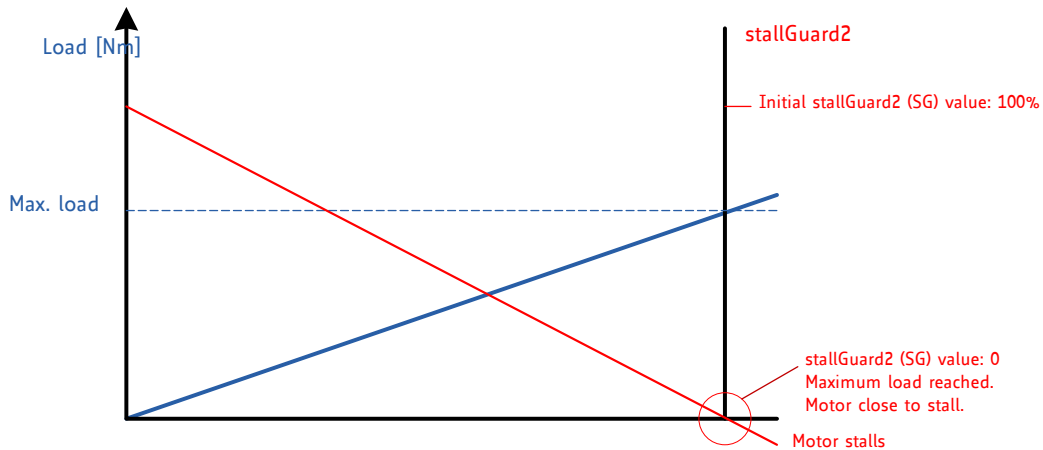

Figure 3: stallGuard2 Load Measurement as a Function of Load

1.4 coolStep

coolStep is a load-adaptive automatic current scaling based on the load measurement via stallGuard2. coolStep adapts the required current to the load. Energy consumption can be reduced by as much as 75%. coolStep allows substantial energy savings, especially for motors which see varying loads or operate at a high duty cycle. Because a stepper motor application needs to work with a torque reserve of 30% to 50%, even a constant-load application allows significant energy savings because coolStep automatically enables torque reserve when required. Reducing power consumption keeps the system cooler, increases motor life, and allows for cost reduction.

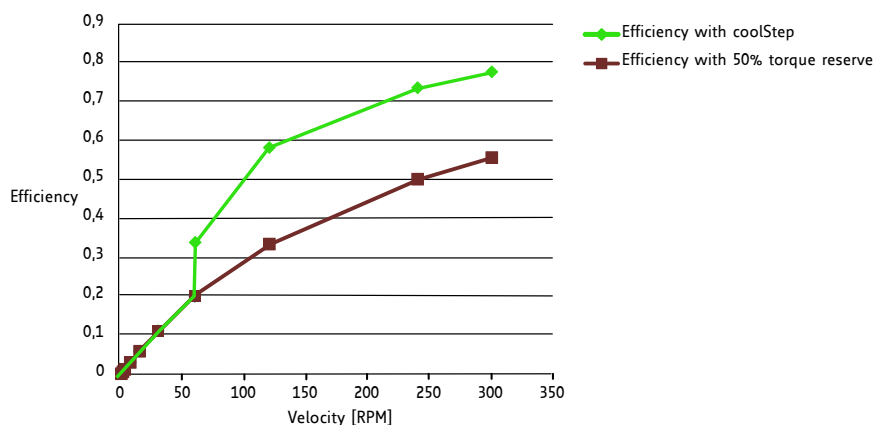

Figure 4: Energy Efficiency Example with coolStep



2 Order Codes

Order Code	Description	Size (LxWxH)
PD42-1-1070	PANdrive, 0.27Nm, 1.0A RMS, +24V DC, TTL UART interface, S/D interface, Enable, Mode Select	42mm x 42mm x 45,5mm
PD42-2-1070	PANdrive, 0.35Nm, 1.0A RMS, +24V DC, TTL UART interface, S/D interface, Enable, Mode Select	42mm x 42mm x 50mm
PD42-3-1070	PANdrive, 0.49Nm, 1.0A RMS, +24V DC, TTL UART interface, S/D interface, Enable, Mode Select	42mm x 42mm x 59mm
TMCM-1070	Controller/Driver Module without motor, +24V DC, TTL UART interface, S/D interface, Enable, Mode Select	42mm x 42mm x 12mm

Table 1: Order codes modules

Order Code	Description
TMCM-1070-CABLE	Cable loom for TMCM-1070. Contains: <ul style="list-style-type: none"> • 1x cable loom for motor connector with 4-pin JST PH female connector • 1x cable loom for I/O connector with 9-in JST PH female connector
PD-1070-CABLE	Cable loom for PD42-x-1070. Contains: <ul style="list-style-type: none"> • 1x cable loom for I/O connector with 9-in JST PH female connector
TMCM-KAMINO-CLIP	Self-Adhesive top hat rail mounting clip for TMCM-1070 base module (not available with PANdrive versions PD42-x-1070)
TMCM-KAMINO-AP23	Aluminum adapter plate kit for mounting of TMCM-1070 base module to NEMA23 size motors (not available with PANdrive versions PD42-x-1070)
TMCM-KAMINO-AP24	Aluminum adapter plate kit for mounting of TMCM-1070 base module to NEMA24 size motors (not available with PANdrive versions PD42-x-1070)

Table 2: Order codes cable loom



3 Mechanical and Electrical Interfacing

3.1 PD42-1070 Dimensions and Weight

The PD42-1070 includes the TMC2130 stepper motor driver module and a NEMA17 bipolar stepper motor. Depending on the motor size the length varies.

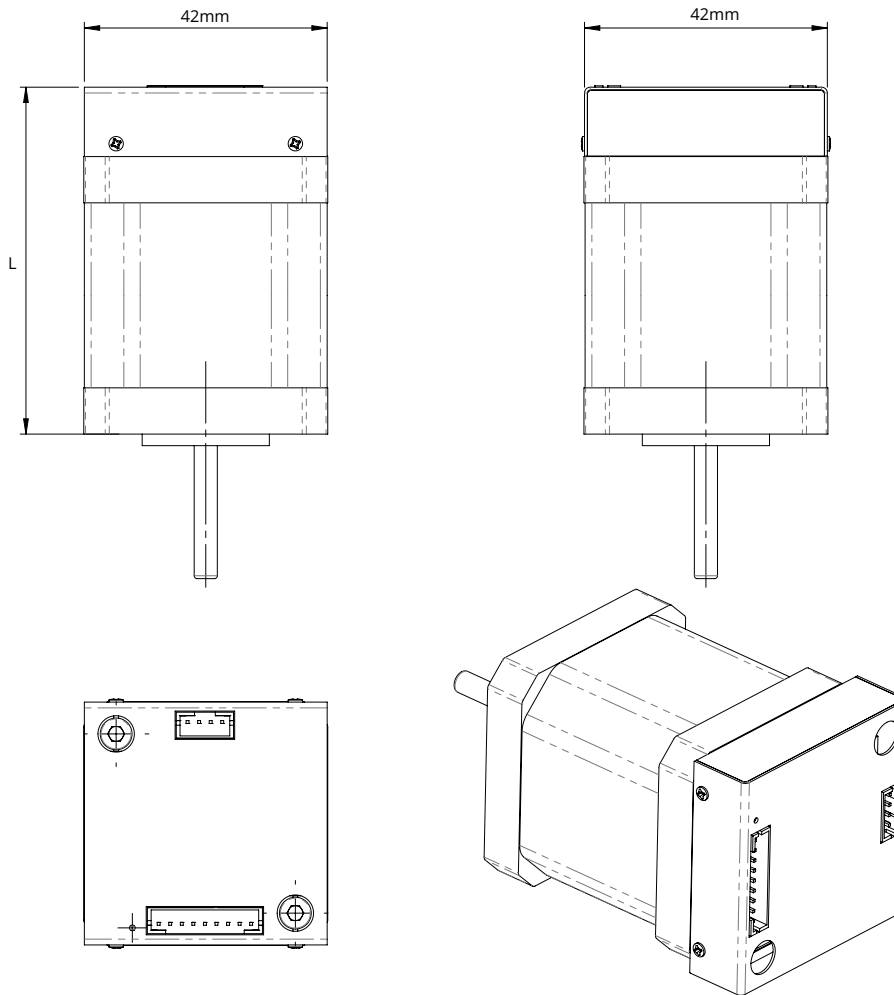

Figure 5: PD42-1070 mechanical dimensions with motor

Order Code	L in mm	Weight in g
PD42-1-1070	45,5 ±1	≈ 260
PD42-2-1070	50 ±1	≈ 320
PD42-3-1070	59 ±1	≈ 395

Table 3: PD42-x-1070 length and weight



3.2 PD42-1070 Motor Parameters

Specifications	Parameter	Unit	PD-1-1070	PD-2-1070	PD-3-1070
Step angle		°	1.8	1.8	1.8
Step angle accuracy		%	±5	±5	±5
Ambient temperature	T_{amb}	°C	-20...+50	-20...+50	-20...+50
Max. motor temperature	$T_{motor_{max}}$	°C	80	80	80
Shaft radial play (450g load)		mm	0,02	0,02	0,02
Shaft axial play (450g load)		mm	0,08	0,08	0,08
Max radial force (20mm from front flange)		N	28	28	28
Max axial force		N	10	10	10
Rated voltage	V_{rated}	V	5.3	4.5	5.0
Rated phase current	$I_{RMS_{rated}}$	A	1.0	1.0	1.0
Phase resistance at 20°C	R_{coil}	Ω	5.3	4.5	5.0
Phase inductance (typ.)	L_{coil}	mH	6.6	7.5	8.0
Holding torque		Nm	0.27	0.35	0.49
Insulation class			B	B	B
Rotor inertia		g cm ²	35	54	68
Weight	M	kg	0.22	0.28	0.35

Table 4: PD42-1070 Motor Parameters



3.3 PD42-1070 Torque Curves

The following diagrams show the torque vs. speed curves for the PD42-1-1070, the PD42-2-1070, and the PD42-3-1070 at three different typical conditions. All measurements have been done in spreadCycle chopper mode. The measurement conditions are:

1. $VDD = +24V, I_{COILRMS} = 1A$, 1/16 microstep with interpolation to 1/256 microstep
2. $VDD = +24V, I_{COILRMS} = 1A$, half stepping
3. $VDD = +12V, I_{COILRMS} = 1A$, half stepping

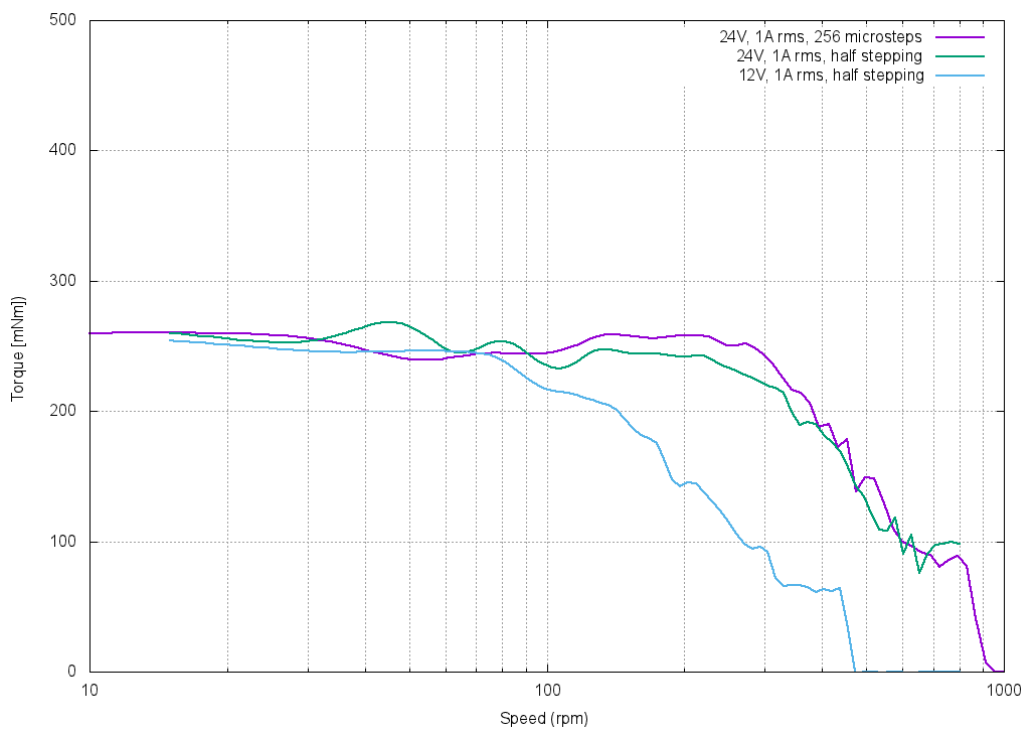

Figure 6: PD42-1-1070 torque vs. speed



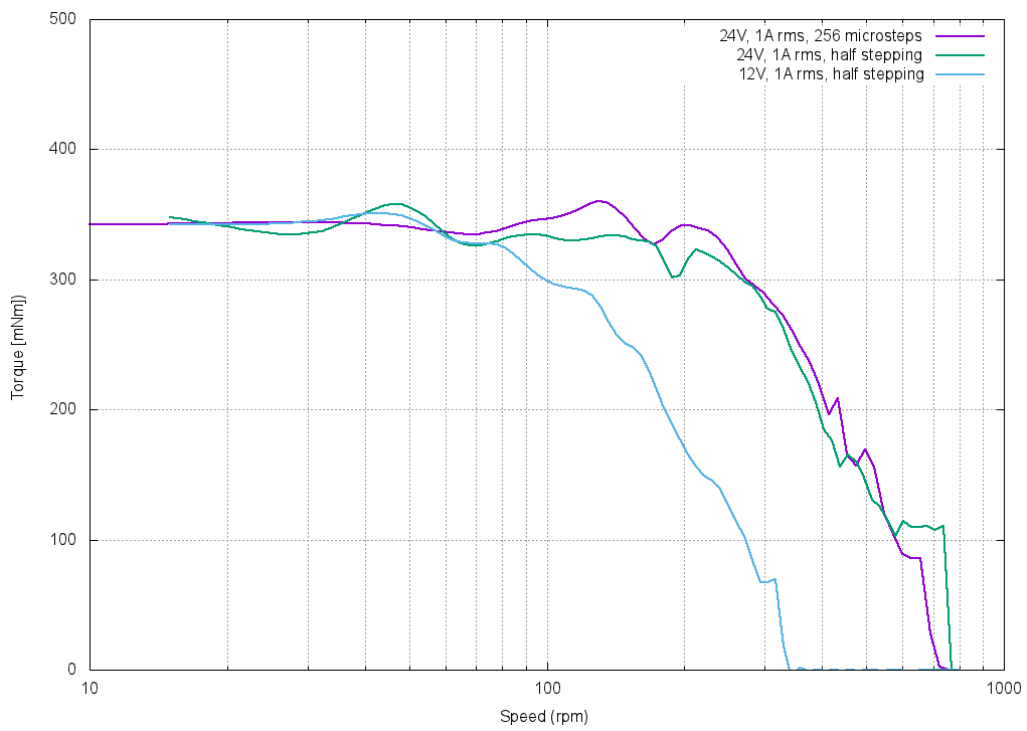

Figure 7: PD42-2-1070 torque vs. speed

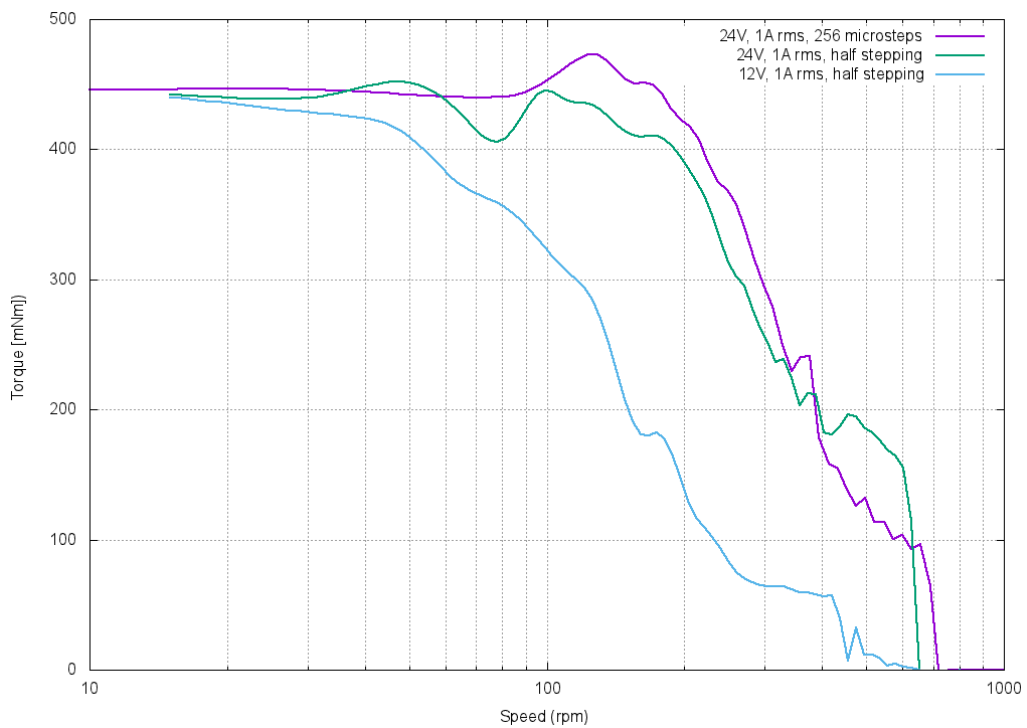

Figure 8: PD42-3-1070 torque vs. speed



4 Connectors and LEDs



Figure 9: PD42-1070 connectors (pin 1 highlighted in red)

4.1 Motor Connector

Pin no.	Pin name	Description
1	A1	Motor phase A pin 1
2	A2	Motor phase A pin 2
3	B1	Motor phase B pin 1
4	B2	Motor phase B pin 2

Table 5: Motor connector pinning

NOTICE

Do not connect or disconnect motor during operation!

Motor cable and motor inductivity might lead to voltage spikes when the motor is (dis)connected while energized. These voltage spikes might exceed voltage limits of the driver MOSFETs and might permanently damage them. Therefore, always switch off or disconnect power supply before (dis)connecting the motor.



4.2 I/O Connector

Pin no.	Pin name	Description
1	GND	Supply ground connection, also used for USB serial converter ground connection
2	V+	Supply voltage (V_{DD}) +9V to +28V DC
3	DIR	Optically isolated direction input of S/D interface
4	STEP	Optically isolated step input of S/D interface
5	EN	Optically isolated enable input of motor driver H-bridges
6	CHOP	Optically isolated chopper mode selection input
7	COMM	Opto-coupler common anode or cathode, connect to ground or VCCIO (3.3V to 24V)
8	RXD	TTL-level UART receive line, use with USB serial converter TXD line to connect to PC
9	TXD	TTL-level UART transmit line, use with USB serial converter RXD line to connect to PC

Table 6: I/O connector pinning

NOTICE

Supply Voltage Buffering / Add External Power Supply Capacitors

A sufficiently buffered power supply or an external electrolyte capacitor connected between V+ and GND is recommended for stable operation. It is recommended to connect an electrolytic capacitor of significant size to the power supply lines next to the PD42-1070.

Rule of thumb for size of electrolytic capacitor: $C = 1000 \frac{\mu F}{A} * I_{SUPPLY}$

The PD42-1070 comes with approximately 40 μ F of onboard ceramic capacitors.

NOTICE

There is no reverse polarity protection on the supply input!

The module will short any reversed supply voltage and board electronics will get damaged.

NOTICE

Power Up Sequence

The PD42-1070 must be powered up with disabled driver stage only. Depending on your configuration the EN input should be logically OFF. For example, if COMM input is connected to 3.3V to 24V, the EN input must be 0V. If common ground or 0V level is connected to COMM input, the EN input must have high level.



4.3 TTL UART Connection

To connect via the TTL UART interface to a host PC, we suggest using a USB serial converter from TTL-UART (5V) to USB interface.

Communication with the host PC, for example when using TRINAMIC’s TMCL-IDE, is done via the Virtual COM port installed by the converter driver.

More information on the TMCL-IDE and the latest release can be found here: www.trinamic.com

The converter cable must be connected to pins 1, 8, and 9 (GND, RXD, TXD) of the I/O connector.

Note

Default Baud Rates

The default baud rate is 9600 bps.
In bootloader mode, the baud rate is 115200 bps.

Info

USB to UART converter

For example, the TTL-232R-5V from FTDI is working with the module and has been tested. More information on this converter is available on the FTDI website: www.ftdichip.com

NOTICE

5V TTL UART Level

The TTL UART interface works with 5V level. Take special care when selecting a converter cable for USB connection.

4.4 Status LEDs

The PD42-1070 has one green status LED. See figure 9 for its location.

State	Description
Blinking	Heartbeat, MCU active, normal operation
Permanent on	Bootloader mode
Off	Power Off

Table 7: LED state description



5 Functional Description

5.1 Typical Application Wiring

Wire the PD42-1070 as shown in the following figures.

- Connect the the power supply to V+ and GND.
- Connect the Step and Direction signals to your motion controller.
- At power up time, the EN input must be low (= driver stage disabled)!
- Optional: Connect UART to a TTL UART interface with 5V logic levels. To configure your PD42-1070 connect start the TMCL-IDE and use the parameterization tools. For detailed instructions refer to the PD42-1070-firmware-manual.

Note The TTL UART interface is not optically isolated. It requires 5V level signals. Nevertheless, it provides basic ESD and rail-to-rail signal line protection for the PD42-1070.

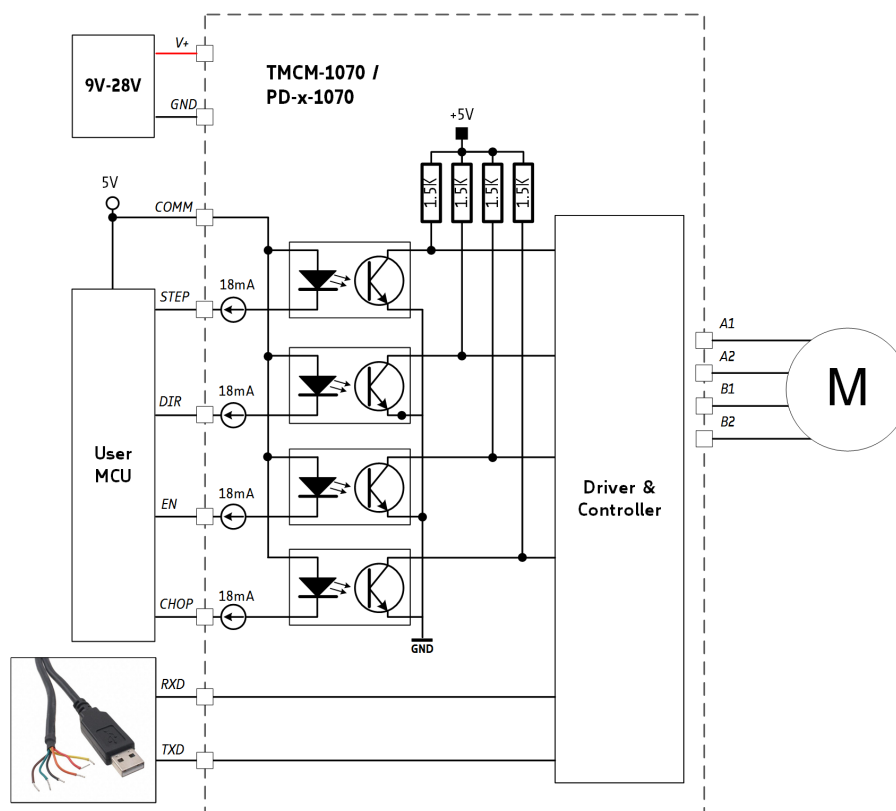

Figure 10: Typical application scenario with 5V inputs

5.2 Optically Isolated Inputs with Common Anode Input

The control inputs of the PD42-1070 are optically isolated (not the TTL UART interface). All optocouplers share one common anode (COMM) input as shown in the figure above.



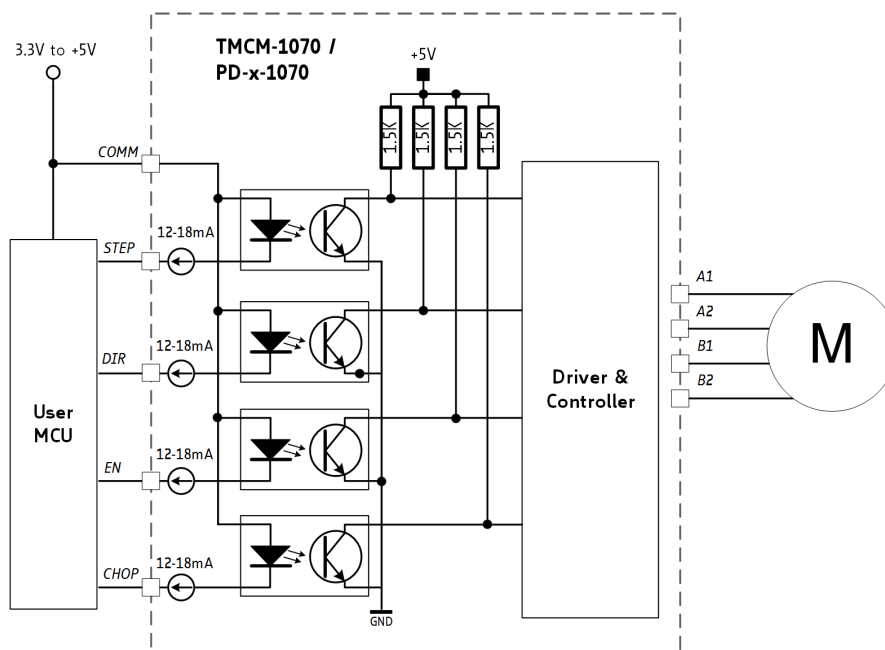

Figure 11: Inputs with common anode input with 3.3V to 5V

The typical voltage at COMM input is 5V. Nevertheless, 3.3V or voltages higher than 5V can also be used as long as the current is through the optocouplers' emitter is between 5mA to 20mA. For 3.3V operation the controller must be carefully selected with respect to its I/O ports, its actual output voltage, and the series resistor of the I/O ports. The user must make sure that the current through the optocouplers' emitter is between 5mA to 20mA.

Note

Step pulse width

Width of the step pulses should be between 2µs and 4µs, for maximum step frequency.

With a larger step pulse width, for example 50% duty cycle coming from a frequency generator, the maximum input frequency will be lower at ca. 9kHz..



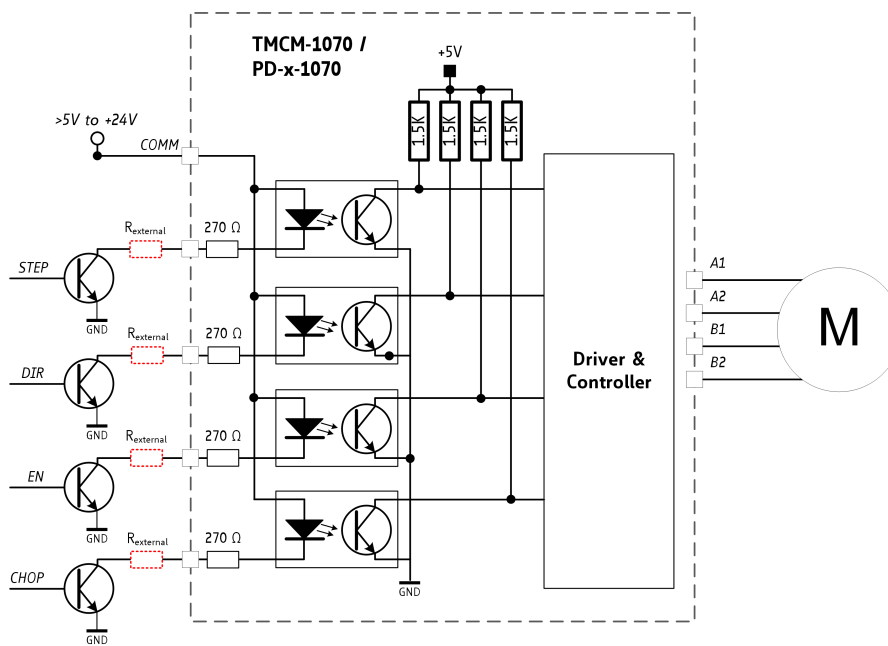

Figure 12: Inputs with common anode input with >5V to 24V

The series resistors in the PD42-1070 are 270mOhms. For operation with voltages higher than 5V an additional external resistor $R_{external}$ is required per input to limit the current. See Table 8 as reference for additional external resistor values.

COMM Voltage (V)	Value of $R_{external}$ (Ω)
3.3	-
5	-
9	300
12	500
15	700
24	1K5

Table 8: Additional resistor reference values

Note $R_{external}$ **Selection**
 Take care when selecting an additional external resistor. The resistor type must have a fitting power rating. This depends on the voltage used at COMM input.

5.3 Optically Isolated Inputs with Common Cathode Input

The optocouplers inside PD42-1070 are bidirectional types (AC/DC). Thus, COMM can also be used as common cathode connection.



5.4 Thermal Behavior

The default configuration parameters of the PD42-1070 are set to the specified maximum current of 1A rms / 1.4A peak, which is the maximum motor phase current specified for the stepper motor options given in Table 4.

Typically, at this nominal current setting the stepper motor and the driver electronics will get hot. Continuous operation at maximum current is not guaranteed without cooling the motor since the stepper driver will switch off due to its internal over-temperature protection until temperature falls below the threshold.

Note

Operation with Maximum Current Setting

For table-top testing and application bring-up the current should be reduced or the coolStep feature should be configured to keep heating on a reasonable level. Especially, when there is no other cooling option for the motor.

For proper and continuous operation at maximum current, the motor flange must be mounted to the applications mechanical interface with good contact.



6 Operational Ratings and Characteristics

6.1 Absolute Maximum Ratings

Parameter	Min	Max	Unit
Supply voltage	+9	+28	V
Working temperature	-30	+40	°C
Motor coil current / sine wave peak		1.4	A
Continuous motor current (RMS)		1.0	A

NOTICE

Avoid exceeding the absolute maximum rating under all circumstances. Stresses above those listed under "Absolute Maximum Ratings" may cause permanent damage to the device. This is a stress rating only and functional operation of the device at those or any other conditions above those indicated in the operation listings of this specification is not implied. Exposure to maximum rating conditions for extended periods may affect device reliability.

Keep the power supply voltage below the upper limit of +28V! Otherwise the board electronics will seriously be damaged! Especially, when the selected operating voltage is near the upper limit a regulated power supply is highly recommended.

6.2 Electrical Characteristics (Ambient Temperature 25° C)

Parameter	Symbol	Min	Typ	Max	Unit
Supply voltage	V_{DD}	9	24	26	V
Motor coil current / sine wave peak (chopper regulated, adjustable via TTL UART interface)	$I_{COILpeak}$	0		1.4	A
Continuous motor current (RMS)	$I_{COILRMS}$	0		1.0	A
Power supply current	I_{DD}		$\ll I_{COIL}$	$1.4 \cdot I_{COIL}$	A

Table 10: Electrical Characteristics

6.3 I/O Ratings (Ambient Temperature 25° C)

Parameter	Symbol	Min	Typ	Max	Unit
COMM input voltage	V_{COMM}	3.3	5	+ V_{DD}	V
Input frequency of optically isolated I/Os	f_{in}			45	kHz
TTL UART input voltage	V_{TTL_IN}		5	5.5	V
TTL UART low level voltage	V_{TLL_L}	0		1.75	V



TTL UART high level voltage	V_{TTL_H}	3.25		5	V
TTL UART output voltage	V_{TTL_OUT}		5		V

Table 11: Operational ratings of optically isolated inputs and TTL UART interface

6.4 Functional Characteristics

Parameter	Description / Value
Control	4-wire interface with Step, Direction, Enable, and Chopper Mode Switch
Step Pulse Width	The step pulse width should be between 2 μ s and 4 μ s for maximum frequency. With a larger step pulse width, for example 50% duty cycle coming from a frequency generator, the maximum input frequency will be lower at ca. 9kHz.
Communication	2-wire TTL UART interface for configuration, 9600-115200 bps (default 57600 bps)
Driving Mode	spreadCycle and stealthChop chopper modes (selectable with CHOP input), adaptive automatic current reduction using stallGuard2 and coolStep
Stepping Resolution	Full, 1/2, 1/4, 1/8, 1/16, 1/32, 1/64, 1/128, 1/256 step, default is 1/16 with internal interpolation to 1/256

Table 12: Functional Characteristics

6.5 Other Requirements

Specifications	Description or Value
Cooling	Free air
Working environment	Avoid dust, water, oil mist and corrosive gases, no condensation, no frosting
Working temperature	-30° C to +40° C

Table 13: Other Requirements and Characteristics



7 Abbreviations used in this Manual

Abbreviation	Description
COMM	Common Anode or common cathode
IDE	Integrated Development Environment
LED	Light Emmitting Diode
RMS	Root Mean Square value
TMCL	TRINAMIC Motion Control Language
TTL	Transistor Transistor Logic
UART	Universal Asynchronous Receiver Transmitter
USB	Universal Serial Bus

Table 14: Abbreviations used in this Manual



8 Figures Index

1	Motor coil sine wave current using stealthChop (measured with current probe)	4	7	PD42-2-1070 torque vs. speed	10
2	spreadCycle principle	4	8	PD42-3-1070 torque vs. speed	10
3	stallGuard2 Load Measurement as a Function of Load	5	9	PD42-1070 connectors (pin 1 highlighted in red)	11
4	Energy Efficiency Example with coolStep	5	10	Typical application scenario with 5V inputs	14
5	PD42-1070 mechanical dimensions with motor	7	11	Inputs with common anode input with 3.3V to 5V	15
6	PD42-1-1070 torque vs. speed	9	12	Inputs with common anode input with >5V to 24V	16



9 Tables Index

1	Order codes modules	6	10	Electrical Characteristics	18
2	Order codes cable loom	6	11	Operational ratings of optically iso- lated inputs and TTL UART interface .	19
3	PD42-x-1070 length and weight	7	12	Functional Characteristics	19
4	PD42-1070 Motor Parameters	8	13	Other Requirements and Characteristics	19
5	Motor connector pinning	11	14	Abbreviations used in this Manual . .	20
6	I/O connector pinning	12	15	Hardware Revision	25
7	LED state description	13	16	Document Revision	25
8	Additional resistor reference values .	16			



10 Supplemental Directives

10.1 Producer Information

10.2 Copyright

TRINAMIC owns the content of this user manual in its entirety, including but not limited to pictures, logos, trademarks, and resources. © Copyright 2019 TRINAMIC. All rights reserved. Electronically published by TRINAMIC, Germany.

Redistributions of source or derived format (for example, Portable Document Format or Hypertext Markup Language) must retain the above copyright notice, and the complete Datasheet User Manual documentation of this product including associated Application Notes; and a reference to other available product-related documentation.

10.3 Trademark Designations and Symbols

Trademark designations and symbols used in this documentation indicate that a product or feature is owned and registered as trademark and/or patent either by TRINAMIC or by other manufacturers, whose products are used or referred to in combination with TRINAMIC's products and TRINAMIC's product documentation.

This Hardware Manual is a non-commercial publication that seeks to provide concise scientific and technical user information to the target user. Thus, trademark designations and symbols are only entered in the Short Spec of this document that introduces the product at a quick glance. The trademark designation /symbol is also entered when the product or feature name occurs for the first time in the document. All trademarks and brand names used are property of their respective owners.

10.4 Target User

The documentation provided here, is for programmers and engineers only, who are equipped with the necessary skills and have been trained to work with this type of product.

The Target User knows how to responsibly make use of this product without causing harm to himself or others, and without causing damage to systems or devices, in which the user incorporates the product.

10.5 Disclaimer: Life Support Systems

TRINAMIC Motion Control GmbH & Co. KG does not authorize or warrant any of its products for use in life support systems, without the specific written consent of TRINAMIC Motion Control GmbH & Co. KG.

Life support systems are equipment intended to support or sustain life, and whose failure to perform, when properly used in accordance with instructions provided, can be reasonably expected to result in personal injury or death.

Information given in this document is believed to be accurate and reliable. However, no responsibility is assumed for the consequences of its use nor for any infringement of patents or other rights of third parties which may result from its use. Specifications are subject to change without notice.

10.6 Disclaimer: Intended Use

The data specified in this user manual is intended solely for the purpose of product description. No representations or warranties, either express or implied, of merchantability, fitness for a particular purpose



or of any other nature are made hereunder with respect to information/specification or the products to which information refers and no guarantee with respect to compliance to the intended use is given.

In particular, this also applies to the stated possible applications or areas of applications of the product. TRINAMIC products are not designed for and must not be used in connection with any applications where the failure of such products would reasonably be expected to result in significant personal injury or death (safety-Critical Applications) without TRINAMIC's specific written consent.

TRINAMIC products are not designed nor intended for use in military or aerospace applications or environments or in automotive applications unless specifically designated for such use by TRINAMIC. TRINAMIC conveys no patent, copyright, mask work right or other trade mark right to this product. TRINAMIC assumes no liability for any patent and/or other trade mark rights of a third party resulting from processing or handling of the product and/or any other use of the product.

10.7 Collateral Documents & Tools

This product documentation is related and/or associated with additional tool kits, firmware and other items, as provided on the product page at: www.trinamic.com.



11 Revision History

11.1 Hardware Revision

Version	Date	Author	Description
1.00	26.06.2016	BS	Initial release.

Table 15: Hardware Revision

11.2 Document Revision

Version	Date	Author	Description
1.00	26.06.2016	BS	Initial release.
1.10	03.07.2018	GE	Order code for PANdrive cable corrected: PD42-1070-CABLE -> PD-1070-CABLE.
1.20	24.01.2019	GE	Motor parameter table 4 corrected + updated.

Table 16: Document Revision



X-ON Electronics

Largest Supplier of Electrical and Electronic Components

Click to view similar products for [Stepper Motors](#) category:

Click to view products by [Analog Devices](#) manufacturer:

Other Similar products are found below :

[HT17-275](#) [5014-020](#) [HT17-271D](#) [82924041](#) [82924036](#) [82914016](#) [80910502](#) [80910501](#) [80910003](#) [HT23-598](#) [HT08-221](#) [902-0135-000](#)
[MS11HS3P4067-09RL](#) [MS17HD6P4200-24RL](#) [MS11HS5P4150-13RL](#) [MS08HY1P4050-09RL](#) [MS08HY3P4050-02RL](#) [ML24HCAL3550-01RL](#) [MS17HD6P4100-16RL](#) [ML23HS8P4220-16RL](#) [MS17HD2P4200-20RL](#) [ML23HSAL4500-E](#) [MS14HS5P4100-03RL](#) [MS17HD2P4100-27RL](#) [MS14HS1P4100-09RL](#) [MS11HS1P4100-25RL](#) [ML23HSAP4300-18RL](#) [ML23HS4P4100-02RL](#) [PL23HS8L4550-05RL](#)
[PL23HSAL4500-05RL](#) [MS17HD4P4150-22RL](#) [PM42S-048-HHC8](#) [PM20L-020-HHC3](#) [PM42L-048-HHC9](#) [82930002](#) [HT34-504](#) [82910003](#)
[103H7823-0440](#) [103H7126-0440](#) [103H8223-5141](#) [103H8223-6340](#) [103H7126-0740](#) [103H7126-5740](#) [103H7822-5740](#) [STEPPER MOTOR BIPOLAR 42X38MM 2.8V 1.7A](#) [SY20STH30-0604A](#) [STEPPER MOTOR: UNIPOLAR/BIPOLAR 57Å—56MM](#) [ROB-10551](#) [STEPPER MOTOR: UNIPOLAR/BIPOLAR 57Å—76MM](#) [103H7123-5740](#)