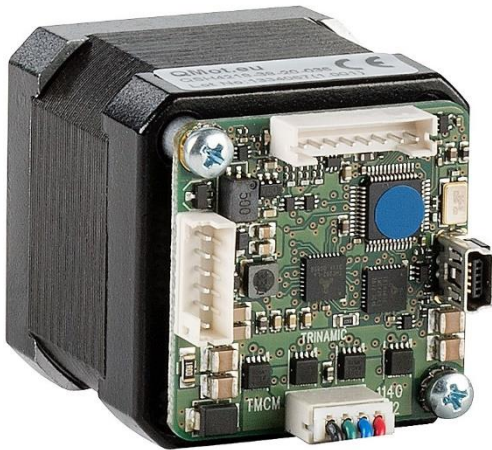


Hardware Version V1.3

# HARDWARE MANUAL



**PD42-1-1140**

**PD42-2-1140**

**PD42-3-1140**

**PD42-4-1140**

Stepper Motor NEMA17 / 42mm  
0.22 - 0.7 Nm  
with Controller / Driver  
up-to 2A RMS / 24V DC  
sens0step™ encoder  
RS485, CAN, USB interfaces



**stallGuard<sup>2</sup>**

TRINAMIC Motion Control GmbH & Co. KG  
Hamburg, Germany

[www.trinamic.com](http://www.trinamic.com)



# Table of contents

1	Life support policy .....	3
2	Features .....	4
3	Order codes .....	6
4	Mechanical and electrical interfacing .....	7
4.1	Dimensions of PD42-x-1140 .....	7
4.2	Stepper motor .....	8
4.3	Integrated sensOstep™ encoder.....	9
4.4	Connectors.....	10
4.4.1	Power and Communication.....	11
4.4.2	Multi-purpose I/O.....	14
4.4.3	Motor.....	18
4.4.4	Mini-USB .....	18
5	Motor driver current .....	20
6	Reset to Factory Defaults .....	21
7	On-Board LEDs.....	22
8	Operational ratings .....	23
9	Torque Curves.....	25
9.1.1	PD42-1-1140 Torque Curve .....	25
9.1.2	PD42-2-1140 Torque Curve .....	25
9.1.3	PD42-3-1140 Torque Curve .....	26
9.1.4	PD42-4-1140 Torque Curve .....	26
10	Functional description .....	27
11	PD42-x-1140 Operational Description.....	28
11.1	Calculation: Velocity and Acceleration vs. Microstep and Fullstep Frequency .....	28
12	Revision history .....	30
12.1	Document revision .....	30
12.2	Hardware revision .....	30
13	References.....	31

# 1 Life support policy

TRINAMIC Motion Control GmbH & Co. KG does not authorize or warrant any of its products for use in life support systems, without the specific written consent of TRINAMIC Motion Control GmbH & Co. KG.

Life support systems are equipment intended to support or sustain life, and whose failure to perform, when properly used in accordance with instructions provided, can be reasonably expected to result in personal injury or death.

© TRINAMIC Motion Control GmbH & Co. KG 2012-2018

Information given in this data sheet is believed to be accurate and reliable. However neither responsibility is assumed for the consequences of its use nor for any infringement of patents or other rights of third parties, which may result from its use.

Specifications are subject to change without notice.



## 2 Features

The PANdrive™ PD42-1-1140, PD42-2-1140, PD-3-1140 and PD42-4-1140 are small and compact full mechatronic solutions including NEMA17 / 42mm flange size stepper motors, the TCM-1140 controller/ driver electronics and TRINAMIC sensOstep™ encoder for step-loss detection. The four PANdrives include stepper motor with different lengths and different holding torques (PD42-1-1140: 0.22Nm, PD42-2-1140: 0.36Nm, PD42-3-1140: 0.44Nm and PD42-4-1140: 0.7Nm) but, same electronics and encoder setup. The PANdrives support both, stand-alone operation e.g. using the on-board I/Os together with the build-in TMCL scripting feature and remote control operation using the RS485 2-wire communication bus interface and even a mixture of both.

### Applications

- Compact and decentralized stepper motor solutions
- Step loss detection for high reliability operation

### Electrical data

- Supply voltage: +24V DC nominal
- Motor current: up to 2.8A peak / 2A RMS (programmable)

### Integrated motion controller

- Motion profile calculation in real-time (TMC429 motion controller)
- On the fly alteration of motor parameters (e.g. position, velocity, acceleration)
- High performance ARM Cortex-M3™ microcontroller for overall system control and serial communication protocol handling

### Integrated bipolar stepper motor driver

- Up to 256 microsteps per full step
- High-efficient operation, low power dissipation (MOSFETs with low  $R_{DS(ON)}$ )
- Dynamic current control
- Integrated protection
- stallGuard2™ feature for stall detection
- Automatic load dependent motor current adaptation for reduced power consumption and heat dissipation (coolStep™)

### Integrated encoder

- Integrated sensOstep™ magnetic encoder (max. 1024 increments per rotation) e.g. for step-loss detection under all operating conditions and positioning

### Integrated motor

- Two phase bipolar stepper motor with 2A RMS nom. coil current
- Holding torque: 0.22Nm, 0.36Nm, 0.44Nm or 0.7Nm

### Interfaces

- RS485 2-wire communication interface
- CAN 2.0B communication interface
- USB full speed (12Mbit/s) device interface
- 4 multi-purpose inputs:
  - 3x general-purpose digital inputs (alternate functions: STOP\_L/STOP\_R/HOME switch inputs or A/B/N encoder input)
  - 1x dedicated analog input
- 2 general purpose outputs
  - 1x open-drain 1A max.
  - 1x +5V supply output – can be switched on/off in software e.g. for encoder / end switch supply

### Software

- Available with TMCL™ or CANopen firmware
- TMCL™ remote (direct mode) and stand-alone operation (memory for up-to 1024 TMCL™ commands)

- CANopen: CiA 301 + CiA 402 (homing mode, profile position mode and velocity mode) supported
- Fully supported by TMCL-IDE (PC based integrated development environment)

Please see separate TMCL™ or CANopen firmware manual and for additional information

## TRINAMICS UNIQUE FEATURES – EASY TO USE WITH TMCL

**stallGuard2™** stallGuard2 is a high-precision sensorless load measurement using the back EMF on the coils. It can be used for stall detection as well as other uses at loads below those which stall the motor. The stallGuard2 measurement value changes linearly over a wide range of load, velocity, and current settings. At maximum motor load, the value goes to zero or near to zero. This is the most energy-efficient point of operation for the motor.

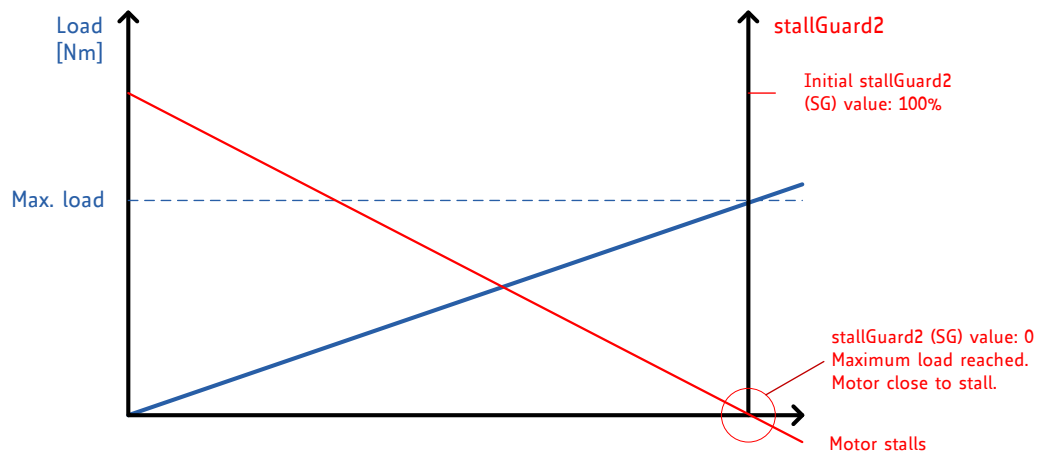


Figure 2.1 stallGuard2 load measurement SG as a function of load

**coolStep™** coolStep is a load-adaptive automatic current scaling based on the load measurement via stallGuard2 adapting the required current to the load. Energy consumption can be reduced by as much as 75%. coolStep allows substantial energy savings, especially for motors which see varying loads or operate at a high duty cycle. Because a stepper motor application needs to work with a torque reserve of 30% to 50%, even a constant-load application allows significant energy savings because coolStep automatically enables torque reserve when required. Reducing power consumption keeps the system cooler, increases motor life, and allows reducing cost.

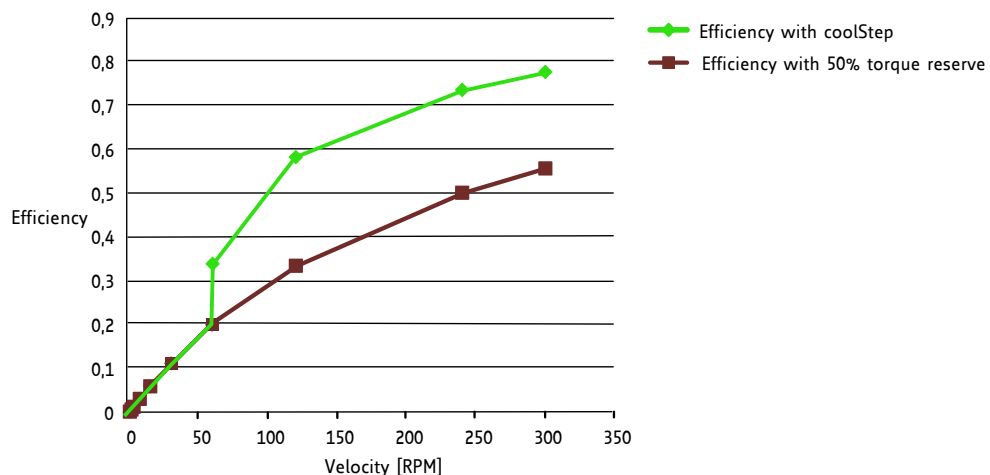


Figure 2.2 Energy efficiency example with coolStep

### 3 Order codes

The combination of motor and motor mounted controller/driver electronic is currently available with three stepper motors (different length and holding torque):

*The length of the PANdrives™ is specified without the length of the axis. For the overall length of the product please add 26 mm (see detailed drawings in chapter 3).*

Order code	Description	Size of unit
PD42-1-1140-option	PANdrive with NEMA17 stepper motor, 0.22Nm max., TCMC-1140 electronics, 2A RMS, +24V, RS485, CAN, USB, sensOstep™ encoder	42mm x 42mm x 47mm
PD42-2-1140-option	PANdrive with NEMA17 stepper motor, 0.36Nm max., TCMC-1140 electronics, 2A RMS, +24V, RS485, CAN, USB, sensOstep™ encoder	42mm x 42mm x 51mm
PD42-3-1140-option	PANdrive with NEMA17 stepper motor, 0.44Nm max., TCMC-1140 electronics, 2A RMS, +24V, RS485, CAN, USB, sensOstep™ encoder	42mm x 42mm x 60mm
PD42-4-1140-option	PANdrive with NEMA17 stepper motor, 0.7N max., TCMC-1140 electronics, 2A RMS, +24V, RS485, CAN, USB, sensOstep™ encoder	42mm x 42mm x 73mm

**Table 3.1: Order codes**

The following options are currently available:

Firmware option	Description	Order code example:
-TMCL	Module pre-programmed with TMCL firmware	TMCM-1140-TMCL
-CANOPEN	Module pre-programmed with CANopen firmware	TMCM-1140-CANOPEN

**Table 3.2: PD42-x-1140 firmware options**

A cable loom set is available for this module, also:

Order code	Description
TMCM-1140-CABLE	Cable loom for TMCM-1140. Contains (see chapter 4.4, also): <ul style="list-style-type: none"> <li>- 1x cable loom for power and communication connector (cable length approx. 200mm)</li> <li>- 1x cable loom for multi-purpose I/O connector (cable length approx. 200mm)</li> <li>- 1x cable loom for motor connector (cable length approx. 200mm)</li> <li>- 1x USB type A connector to mini-USB type B connector cable</li> </ul>

**Table 3.3: Cable loom order code**

## 4 Mechanical and electrical interfacing

All PD42-x-1140 consist of one out of four available NEMA17 / 42mm stepper motors with 2A RMS rated coil current with the same TCM-1140 controller / driver electronics mounted on its backside and integrated sensOstep™ encoder. The PD42-1-1140 uses the QSH4218-34-20-022 stepper motor with 0.22Nm holding torque, the PD42-2-1140 uses the QSH4218-38-20-036 stepper motor with 0.36Nm holding torque, the PD42-3-1140 uses the QSH4218-47-20-044 stepper motor with 0.44Nm holding torque and the PD42-4-1140 uses the QSH4218-60-20-070 stepper motor with 0.7Nm holding torque.

Please see also stepper motor manuals and TCM-1140 hardware and firmware manuals for more details.

**Note:**  
 In order to make proper use of the integrated sensOstep™ encoder (the sensor IC is placed on the bottom of the pcb) the TCM-1140 electronics should not be removed/moved relative to the motor.  
 In case the integrated encoder feature is not used, the electronics may be moved or even removed from the motor and placed somewhere else according to application requirements.

### 4.1 Dimensions of PD42-x-1140

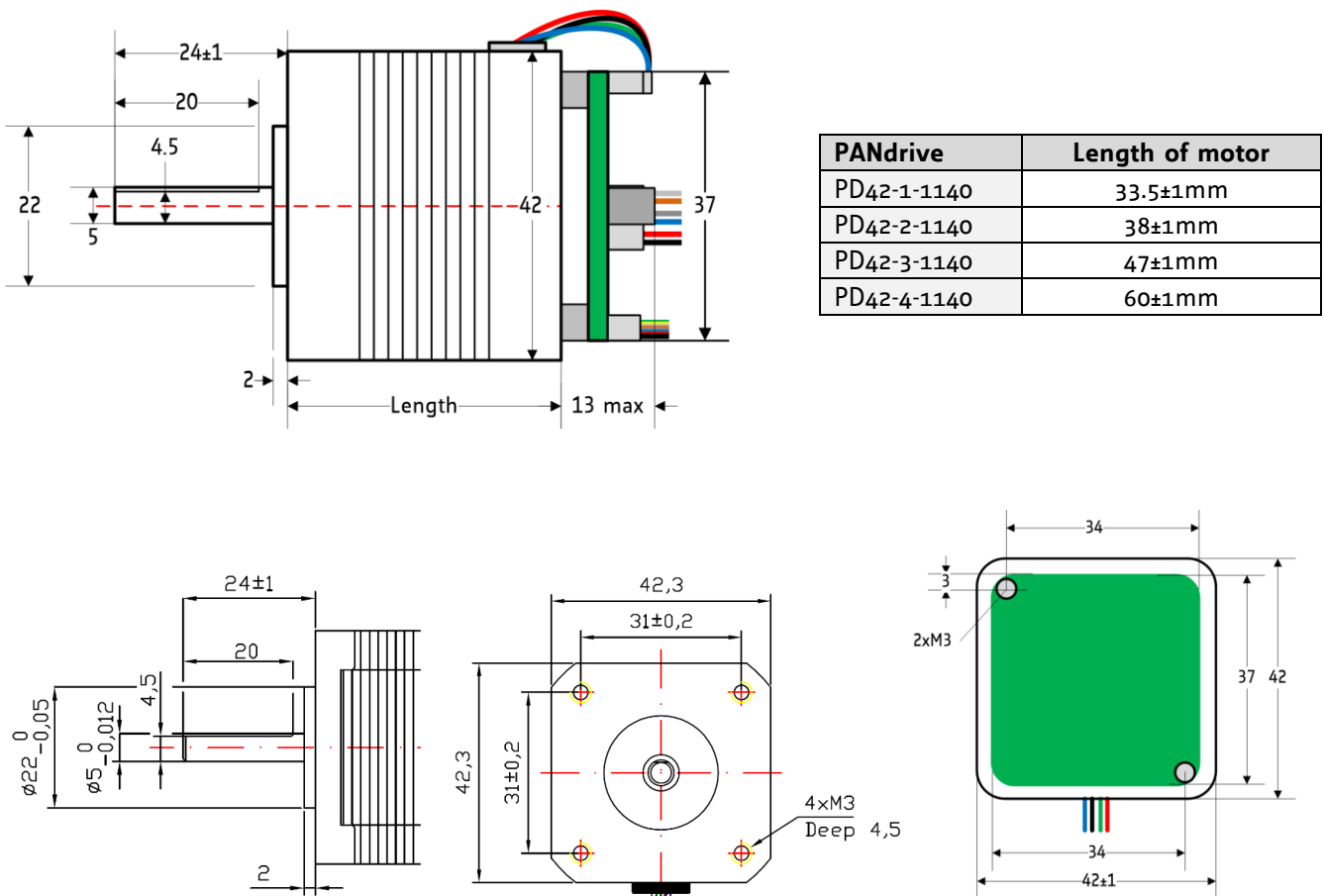


Figure 4.1: PD42-x-1140 with different NEMA 17 / 42mm stepper motors (all dimensions in mm)

## 4.2 Stepper motor

Main characteristics of the four different motors available as part of the PD42-x-1140 PANdrive™:

Specifications	Parameter	Units	QSH4218			
			-34-20-022	-38-20-036	-47-20-044	-60-20-070
Related PANdrive			PD42-1-1140	PD42-2-1140	PD42-3-1140	PD42-4-1140
Step angle		°	1.8	1.8	1.8	1.8
Step angle accuracy		%	+/-5	+/-5	+/-5	+/-5
Ambient temperature		°C	-20 ... +50	-20 ... +50	-20 ... +50	-20 ... +50
Max. motor temperature		°C	80	80	80	80
Shaft radial play (450g load)		mm	0.02	0.02	0.02	0.02
Shaft axial play (450g load)		mm	0.08	0.08	0.08	0.08
Max radial force (20mm from front flange)		N	28	28	28	28
Max axial force		N	10	10	10	10
Rated voltage	$V_{RATED}$	V	2.0	2.4	2.4	4.4
Rated phase current	$I_{RMS RATED}$	A	2.0	2.0	2.0	2.0
Phase resistance at 20°C	$R_{COIL}$	Ω	1.0	1.2	1.4	2.3
Phase inductance (typ.)		mH	1.6	2.2	2.1	6.0
Holding torque		Nm	0.22	0.36	0.44	0.70
Insulation class			B	B	B	B
Rotor inertia		g cm <sup>2</sup>	35	57	68	102
Weight		kg	0.22	0.24	0.35	0.5



Table 4.1: NEMA 17 / 42mm stepper motor technical data



### 4.3 Integrated sensOstep™ encoder

The PD42-x-1140 PANdrives offer integrated sensOstep™ encoders based on hall sensor technology. As the name "sensOstep™" already indicates intended use of this type of compact and highly integrated encoder is step loss detection of motor movements. As soon as the motor has been moved to a new location the position may be verified using this encoder feedback. In case the stepper motor has lost one or multiple steps during movement e.g. due to overload / any obstacle encountered during movement the motor axes will jump for at least one electrical period / 4 full steps. This can be detected using the integrated encoder. In addition, step losses may be already detected during motor movements using the "deviation" setting available as part of the TMCL firmware (see PD42-x-1140 / TMCM-1140 firmware manual for more details).

While the encoder offers 10bit (1024 steps) resolution per motor revolution the absolute position information is less accurate and depends on the displacement of the hall sensor based encoder IC relative to the magnet and motor axis among other factors. Every PANdrive™ has been tested for maximum deviation of +/- 5 encoder steps (static performance) relative to commanded microstep target position during final tests after assembly at our factory. This will ensure more than adequate performance of the integrated sensOstep™ encoder for step loss detection during motor movements.

	<p><b>Do not disassemble PANdrive™ when using integrated encoder</b></p> <p>In order to make proper use of the integrated sensOstep™ encoder (the sensor IC is placed on the bottom center of the pcb) the TMCM-1140 electronics should not be removed/moved relative to the motor! Otherwise encoder performance might suffer / not work.</p> <p><i>Note: In case the integrated encoder feature is not used, the TMCM-1140 electronics may be moved or even removed from the motor and placed somewhere else according to application requirements.</i></p>
	<p><b>Keep the electronics free of (metal) particles!</b></p> <p>The integrated sensOstep™ encoder uses a magnet at the end of the motor axis in order to monitor position of the motor axis. The magnet naturally attracts especially tiny metal particles. These particles might be held on the top side of the PCB and even worse – start moving in accordance with the rotating magnetic field as soon as the motor starts moving. This might lead to shorts of electronic contacts / wires on the board and totally erratic behavior of the module! Use compressed air for cleaning the module if necessary (especially in prototype setups).</p> <p><i>In order to prevent shorts and better protect the electronics the TMCM-1140 printed circuit board is coated after assembly of components since hardware version V1.3.</i></p>

## 4.4 Connectors

The PD42-x-1140 offers four connectors including the motor connector which is used for connecting the motor coils to the electronics. The power and communication connector is used for power supply, CAN interface, and RS485 interface. The 8pin multipurpose I/O connector offers four multipurpose inputs and two general purpose outputs. Further, there is a connector for the USB interface.

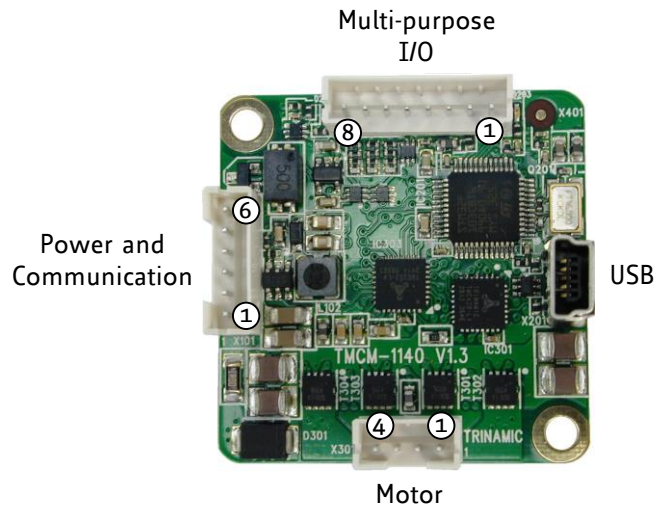


Figure 4.2: PD42-x-1140 connectors

Overview of connector and mating connector types:


Label	Connector type	Mating connector type
Power and Communication Connector	CI0106P1VKo-LF CVIlux CI01 series, 6 pins, 2mm pitch	Connector housing CVIlux: CI01065000-A Contacts CVIlux: CI01T011PEo-A <i>or</i> Connector housing JST: PHR-6 Contacts JST: SPH-002T-Po.5S Wire: 0.22mm <sup>2</sup>
Multi-purpose I/O Connector	CI0108P1VKo-LF CVIlux CI01 series, 8 pins, 2mm pitch	Connector housing CVIlux: CI01085000-A Contacts CVIlux: CI01T011PEo-A <i>or</i> Connector housing JST: PHR-8 Contacts JST: SPH-002T-Po.5S Wire: 0.22mm <sup>2</sup>
Motor Connector	CI0104P1VKo-LF CVIlux CI01 series, 4 pins, 2mm pitch	Connector housing CVIlux: CI01045000-A Contacts CVIlux: CI01T011PEo-A <i>or</i> Connector housing JST: PHR-4 Contacts JST: SPH-002T-Po.5S Wire: 0.22mm <sup>2</sup>
Mini-USB Connector	Molex 500075-1517 Mini USB Type B vertical receptacle	Any standard mini-USB plug

Table 4.2: Connectors and mating connectors, contacts and applicable wire

## 4.4.1 Power and Communication

A 6pin 2mm pitch single row connector is used for power supply, RS485 and CAN serial communication.

*Note: CAN interface will be de-activated in case USB is connected due to internal sharing of hardware resources.*




	Pin	Label	Direction	Description
	1	GND	Power (GND)	System and signal ground
	2	VDD	Power (Supply)	VDD (+9V...+28V)
	3	RS485+	Bidirectional	RS485 interface, diff. signal (non-inverting)
	4	RS485-	Bidirectional	RS485 interface, diff. signal (inverting)
	5	CAN_H	Bidirectional	CAN interface, diff. signal (non-inverting)
	6	CAN_L	Bidirectional	CAN interface, diff. signal (inverting)

**Table 4.3: Power and communication connector**

### 4.4.1.1 Power Supply

For proper operation care has to be taken with regard to power supply concept and design. Due to space restrictions the TCM-1140 includes about 40µF/35V of supply filter capacitors. These are ceramic capacitors which have been selected for high reliability and long life time. The module includes a 28V suppressor diode for over-voltage protection.

#### CAUTION!

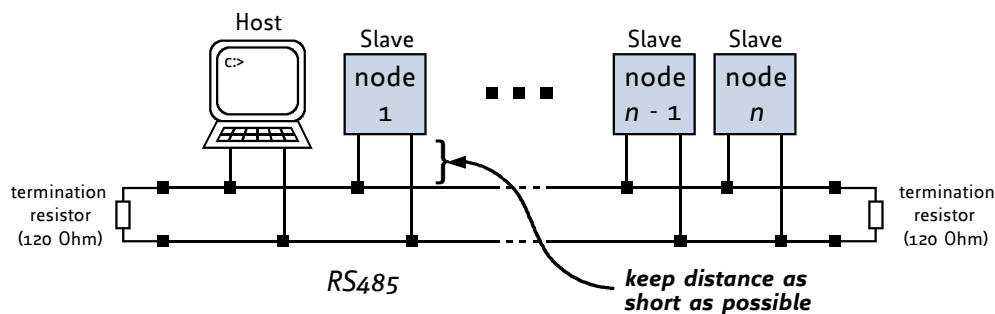
	<p><b>Add external power supply capacitors!</b></p> <p>It is recommended to connect an electrolytic capacitor of significant size (e.g. at least 470µF/35V) to the power supply lines next to the PD42-x-1140!</p> <p>Rule of thumb for size of electrolytic capacitor: <math>c = 1000 \frac{\mu\text{F}}{\text{A}} \times I_{\text{SUPPLY}}</math></p> <p>In addition to power stabilization (buffer) and filtering this added capacitor will also reduce any voltage spikes which might otherwise occur from a combination of high inductance power supply wires and the ceramic capacitors. In addition it will limit slew-rate of power supply voltage at the module. The low ESR of ceramic-only filter capacitors may cause stability problems with some switching power supplies.</p>
	<p><b>Keep the power supply voltage below the upper limit of 28V!</b></p> <p>Otherwise the driver electronics will seriously be damaged! Especially, when the selected operating voltage is near the upper limit a regulated power supply is highly recommended. Please see also chapter Fehler! Verweisquelle konnte nicht gefunden werden., operating values.</p>
	<p><b>There is no reverse polarity protection!</b></p> <p>The module will short any reversed supply voltage due to internal diodes of the driver transistors.</p>

### 4.4.1.2 RS485

For remote control and communication with a host system the PD42-x-1140 provides a two wire RS485 bus interface. For proper operation the following items should be taken into account when setting up an RS485 network:

1. **BUS STRUCTURE:**

The network topology should follow a bus structure as closely as possible. That is, the connection between each node and the bus itself should be as short as possible. Basically, it should be short compared to the length of the bus.



**Figure 4.3: Bus structure**

2. **BUS TERMINATION:**

Especially for longer busses and/or multiple nodes connected to the bus and/or high communication speeds, the bus should be properly terminated at both ends. The PD42-x-1140 does not integrate any termination resistor. Therefore, 120 Ohm termination resistors at both ends of the bus have to be added externally.

3. **NUMBER OF NODES:**

The RS485 electrical interface standard (EIA-485) allows up to 32 nodes to be connected to a single bus. The bus transceivers used on the PD42-x-1140 units (TMCM-1140 hardware V1.2: SN65HVD3082ED, since TMCM-1140 hardware V1.3: SN65HVD1781D) have a significantly reduced bus load and allow a maximum of 255 units to be connected to a single RS485 bus using TMCL firmware. *Please note: usually it cannot be expected to get reliable communication with the maximum number of nodes connected to one bus and maximum supported communication speed at the same time. Instead, a compromise has to be found between bus cable length, communication speed and number of nodes.*

4. **COMMUNICATION SPEED:**

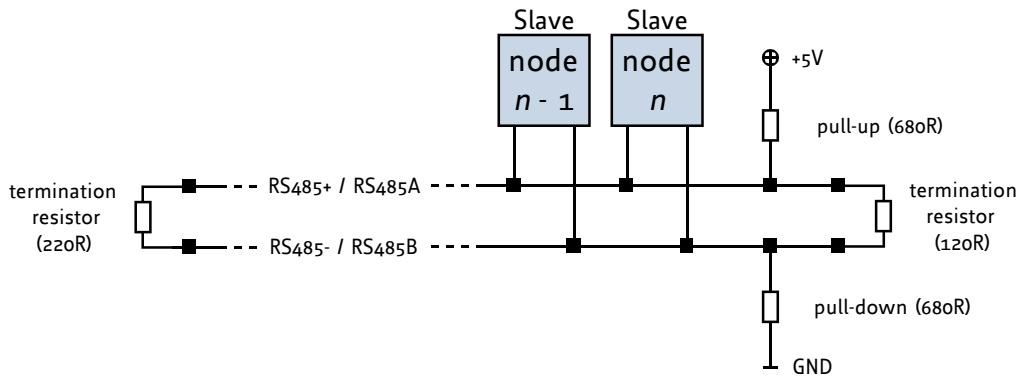
The maximum RS485 communication speed supported by the PD42-x-1140 with TMCM-1140 hardware V1.2 is 115200 bit/s and 1Mbit/s since TMCM-1140 hardware V1.3. Factory default is 9600 bit/s. *Please see separate PD42-x-1140 / TMCM-1140 TMCL firmware manual for information regarding other possible communication speeds below the upper limit in hardware.*

5. **NO FLOATING BUS LINES:**

Avoid floating bus lines while neither the host/master nor one of the slaves along the bus line is transmitting data (all bus nodes switched to receive mode). Floating bus lines may lead to communication errors. In order to ensure valid signals on the bus it is recommended to use a resistor network connecting both bus lines to well defined logic levels.

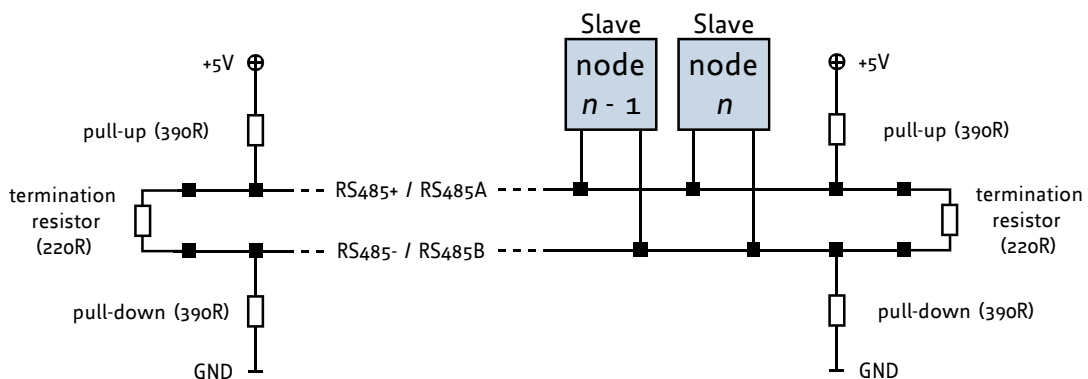
There are actually two options which can be recommended:

Add resistor (Bias) network on **one** side of the bus, only (120R termination resistor still at **both** ends):



**Figure 4.3: Bus lines with resistor (Bias) network on one side, only**

Or add resistor (Bias) network at **both** ends of the bus (like Profibus™ termination):



**Figure 4.4: Bus lines with resistor (Bias) network at both ends**

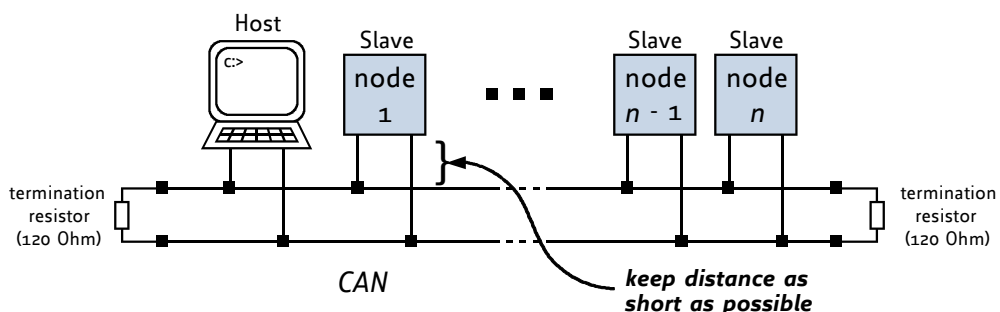
Certain RS485 interface converters available for PCs already include these additional resistors (e.g. USB-2-485 with bias network at one end of the bus).

### 4.4.1.3 CAN

For remote control and communication with a host system the PD42-x-1140 provides a CAN bus interface. Please note that the CAN interface is not available in case USB is connected. For proper operation the following items should be taken into account when setting up a CAN network:

1. **BUS STRUCTURE:**

The network topology should follow a bus structure as closely as possible. That is, the connection between each node and the bus itself should be as short as possible. Basically, it should be short compared to the length of the bus.



**Figure 4.5 CAN bus structure**

2. *BUS TERMINATION:*


Especially for longer busses and/or multiple nodes connected to the bus and/or high communication speeds, the bus should be properly terminated at both ends. The PD42-x-1140 does not integrate any termination resistor. Therefore, 120 Ohm termination resistors at both ends of the bus have to be added externally.

3. *NUMBER OF NODES:*

The bus transceiver used for the PD42-x-1140 (TJA1050T) supports at least 110 nodes under optimum conditions. Practically achievable number of nodes per CAN bus highly depend on bus length (longer bus -> less nodes) and communication speed (higher speed -> less nodes).

## 4.4.2 Multi-purpose I/O

An 8pin 2mm pitch single row connector is available for all multi-purpose inputs and outputs.

	Pin	Label	Direction	Description
	1	GND	Power (GND)	System and signal ground
	2	VDD	Power (Supply)	VDD, connected to VDD pin of the power and communication connector
	3	OUT_o	Output	Open-drain output (max. 1A) Integrated freewheeling diode to VDD
	4	OUT_1	Output	+5V supply output (max. 100mA) Can be switched on/off in software
	5	IN_o	Input	Dedicated analog input, Input voltage range: 0..+10V Resolution: 12bit (0..4095)
	6	IN_1, STOP_L, ENC_A	Input	General purpose digital input (+24V compatible) Alternate function 1: left stop switch input Alternate function 2: external incremental encoder channel A input
	7	IN_2, STOP_R, ENC_B	Input	General purpose digital input (+24V compatible) Alternate function 1: right stop switch input Alternate function 2: external incremental encoder channel B input
	8	IN_3, HOME, ENC_N	Input	General purpose digital input (+24V compatible) Alternate function 1: home switch input Alternate function 2: external incremental encoder index / zero channel input

**Table 4.4 Multipurpose I/O connector**

**Note:**

- All inputs have resistor based voltage input dividers with protection diodes. These resistors also ensure a valid GND level when left unconnected.
- For all digital inputs (IN\_1, IN\_2, IN\_3) a 2k2 pull-up resistor to +5V can be activated (default setting with all more recent TMCL firmware versions). Then these inputs have a default (unconnected) logic level of 1 and an external switch to GND can be connected. This might be especially interesting in case these inputs are used as STOP\_L / STOP\_R and HOME switch inputs (alternate function 1) or as encoder input for an external incremental A/B/N encoder with open-collector outputs (pull-ups are not necessary for encoder with push-pull outputs).

### 4.4.2.1 Digital Inputs IN\_1, IN\_2, IN\_3

The eight pin connector of the PD42-x-1140 provides three multipurpose digital inputs IN\_1, IN\_2 and IN\_3. All three inputs accept up to +24V (nom.) input signals and offer the same input circuit with voltage resistor dividers, limiting diodes against over- and under-voltage and programmable 2k $\Omega$  pull-up resistors. The pull-ups can be switched on or off for all three inputs at once in software.

With TMCL firmware command `SIO 0, 0, 0` will switch-off the pull-ups and command `SIO 0, 0, 1` will switch them on (see separate TMCL firmware manual, command `SIO` for more detailed information).

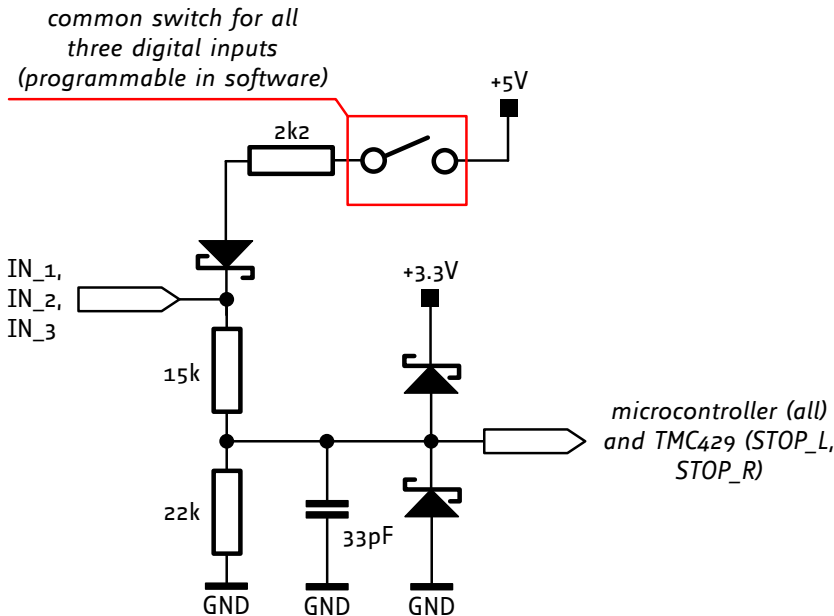


Figure 4.6 General purpose inputs (simplified input circuit)

The three digital inputs have alternate functionality depending on configuration in software. The following functions are available:

Label (pin)	Default function	Alternate function 1	Alternate function 2
IN_1 (6)	General purpose digital input <i>TMCL: GIO 1, 0 // get digital value of input IN_1</i>	STOP_L - left stop switch input, connected to processor and TMC429 REF input (supporting left stop functionality in hardware) <i>TMCL: GAP 11, 0 // get digital value of STOP_L input</i>	ENC_A - external incremental encoder input channel A, connected to processor encoder counter input
IN_2 (7)	General purpose digital input <i>TMCL: GIO 2, 0 // get digital value of input IN_2</i>	STOP_R - right stop switch input, connected to processor and TMC429 REF input (supporting right stop switch functionality in hardware) <i>TMCL: GAP 10, 0 // get digital value of STOP_R input</i>	ENC_B - external incremental encoder input channel B, connected to processor encoder counter input
IN_3 (8)	General purpose digital input <i>TMCL: GIO 3, 0 // get digital value of input IN_3</i>	HOME - home switch input, connected to processor <i>TMCL: GAP 9, 0 // get digital value of HOME input</i>	ENC_N - external incremental encoder input index / zero channel, connected to processor interrupt input

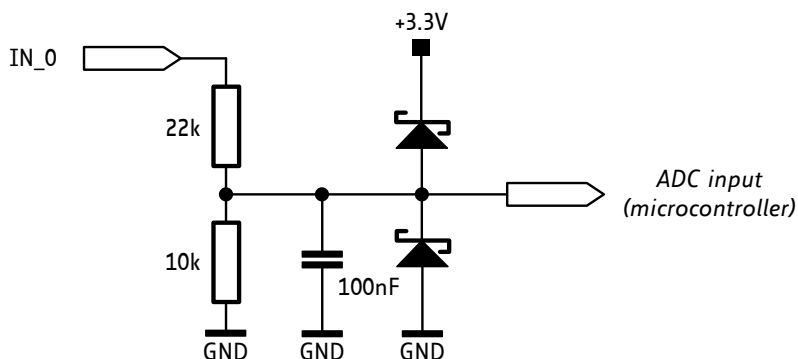
Table 4.5 Multipurpose inputs / alternate functions

- All three digital inputs are connected to the on-board processor and can be used as general purpose digital inputs (default).
- In order to use IN\_1 and IN\_2 as STOP\_L and STOP\_R inputs, this function has to be enabled explicitly in software (factory default: switched off). With TMCL firmware the stop switch functionality can be enabled using SAP 12, 0, 0 (STOP\_R / right limit switch) and SAP 13, 0, 0 (STOP\_L / left limit switch). As the names already indicate: the status of the left limit switch (STOP\_L) will be significant during motor left turns and the status of the right limit switch during motor right turns (positive direction), only. Reading out input values using the GAP commands as listed in the table above is possible at any time. Please see separate TMCL firmware manual for additional information.
- External encoder: an external incremental A/B/N encoder can be connected to the TMCM-1140 and used in addition or as an alternative to the internal sensOstep™ encoder. Using TMCL the encoder counter value for this second encoder can be read out via TMCL command GAP 216, 0 (see separate TMCL firmware manual for more details). Factory default scaling of the encoder counter is 1:1 - that is, after one encoder rotation the encoder counter will be incremented / decremented by the number of encoder ticks (encoder lines x 4). When using an external encoder connect encoder channel A to IN\_1, channel B to IN\_2, the N or zero channel to IN\_3 (optional), encoder ground to module supply ground (e.g. Pin 1 of the Multipurpose I/O connector) and the +5V supply input of the encoder to OUT\_1 (all on the Multipurpose I/O connector). Please note that in order to supply the encoder with +5V the output OUT\_1 has to be activated first using SIO 1, 2, 1 (see also chapter 3.3.2.3).

#### 4.4.2.2 Analog Input IN\_o

The eight pin connector of the PD42-x-1140 provides one dedicated analog input IN\_o. This dedicated analog input offers a full scale input range of approx. 0... +10 V (0..+10.56V nom.) with a resolution of the internal analog-to-digital converter of the microcontroller of 12bit (0... 4095).

The input is protected against higher voltages up to +24 V using voltage resistor dividers together with limiting diodes against voltages below 0 V (GND) and above +3.3 V DC (see figure below).



**Figure 4.7 General purpose inputs (simplified input circuit)**

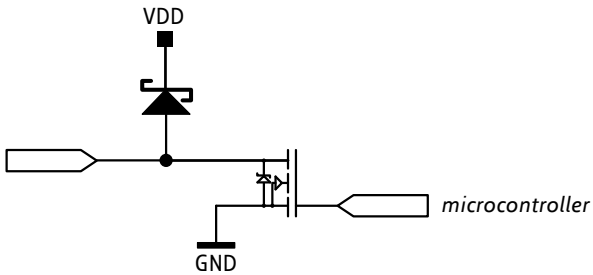
With TMCL firmware the analog value of this input may be read using command GIO 0, 1. The command will return the raw value of the 12bit analog-to-digital converter between 0 .. 4095. It is also possible to read the digital value of this input using TMCL command GIO 0, 0. The trip point (between 0 and 1) will be at approx. +5V input voltage (half the analog input range).

#### 4.4.2.3 Outputs OUT\_o, OUT\_1

The eight pin connector of the PD42-x-1140 offers two general purpose outputs OUT\_o and OUT\_1. OUT\_o is an open-drain output capable of switching (sinking) up to 1A. The output of the N-channel MOSFET transistors is connected to a freewheeling diode for protection against voltage spikes especially from inductive loads (relais etc.) above supply voltage (see figure below).

OUT\_o should not be connected to any voltage above supply voltage of the module due to the internal freewheeling diode.

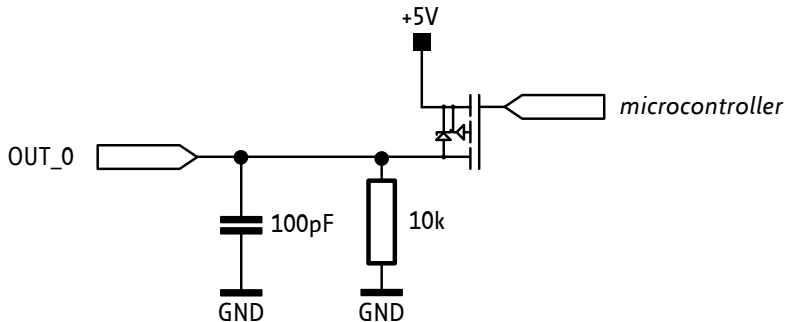




**Figure 4.8 General purpose output OUT\_0 (simplified circuit)**

With TMCL firmware *OUT\_0* can be switched **on** (*OUT\_0* pulled low) using command *SIO 0, 2, 1* and off again (*OUT\_0* floating) using command *SIO 0, 2, 0* (this is also the factory default setting of this output). In case a floating output is not desired in the application an external resistor to e.g. supply voltage may be added.

In contrast *OUT\_1* is able to supply +5V (sourcing 100mA max.) to an external load. An integrated P-channel MOSFET allows switching on / off this +5V supply in software (see figure below). This output might be used in order to supply +5V to an external encoder circuit. Please note that the +5V supply has to be activated explicitly in software.




**Figure 4.9 General purpose output OUT\_1 (simplified circuit)**

With TMCL firmware *OUT\_1* can be switched **on** (supply +5V to external circuit) using command *SIO 1, 2, 1* and **off** (output pulled low via 10k pull-down resistor) using command *SIO 1, 2, 0* (this is also the factory default setting of this output).


### 4.4.3 Motor

As motor connector a 4pin connector is available. The motor connector is used for connecting the four motor wires of the two motor coils of the bipolar stepper motor to the electronics.



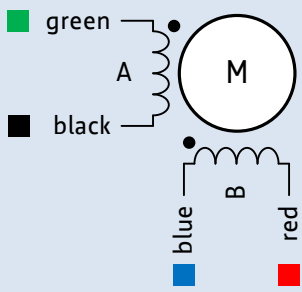
**Do not connect or disconnect motor during operation!**

Motor cable and motor inductivity might lead to voltage spikes when the motor is disconnected / connected while energized. These voltage spikes might exceed voltage limits of the driver MOSFETs and might permanently damage them. Therefore, always disconnect power supply before connecting / disconnecting the motor.

	Pin	Label	Direction	Description
	1	OB2	Output	Pin 2 of motor coil B
	2	OB1	Output	Pin 1 of motor coil B
	3	OA2	Output	Pin 2 of motor coil A
	4	OA1	Output	Pin 1 of motor coil A

**Table 4.6: Motor connector**


Example for connecting the QSH4218 NEMA 17 / 42mm stepper motors:

PD42-1-1140 PD42-2-1140 PD42-3-1140 PD42-4-1140	QSH4218-34-20-022 QSH4218-38-20-036 QSH4218-47-20-044 QSH4218-60-20-070		
Motor connector pin	Cable colour	Coil	Description
1	Red	B	Motor coil B pin 1
2	Blue	B-	Motor coil B pin 2
3	Green	A-	Motor coil A pin 2
4	Black	A	Motor coil A pin 1

### 4.4.4 Mini-USB

A 5pin mini-USB connector is available on-board for serial communication (as alternative to the CAN and RS485 interface). This module supports USB 2.0 Full-Speed (12Mbit/s) connections.

CAN interface will be de-activated as soon as USB is connected due to internal sharing of hardware resources.

	Pin	Label	Direction	Description
	1	VBUS	Power (supply input)	+5V supply from host
	2	D-	Bidirectional	USB Data -
	3	D+	Bidirectional	USB Data +
	4	ID	Power (GND)	Connected to signal and system ground
	5	GND	Power (GND)	Connected to signal and system ground

**Table 4.7 Connector for USB**

For remote control and communication with a host system the PD42-x-1140 provides a USB 2.0 full-speed (12Mbit/s) device interface (mini-USB connector). As soon as a USB-Host is connected the module will accept commands via USB.

### USB BUS POWERED OPERATION MODE

The PD42-x-1140 PANdrives™ support both, USB self powered operation (when an external power is supplied via the power supply connector) and USB bus powered operation, (no external power supply via power supply connector).

On-board digital core logic will be powered via USB in case no other supply is connected (USB bus powered operation). The digital core logic includes the microcontroller itself and also the EEPROM. The *USB bus powered operation mode* has been implemented to enable configuration, parameter settings, read-outs, firmware updates, etc. by just connecting an USB cable between module and host PC. No additional cabling or external devices (e.g. power supply) are required.

Please note that the module might draw current from the USB +5V bus supply even in USB self powered operation depending on the voltage level of this supply.

Motor movements are not possible in this mode. Therefore, always connect a power supply to the *Power and Communication Connector* for motor movements.

## 5 Motor driver current

The integrated stepper motor driver operates current controlled. The driver current may be programmed in software for motor coil currents up-to 2A RMS with 32 effective scaling steps in hardware (CS in table below).

Explanation of different columns in table below:

**Motor current setting in software (TMCL)** These are the values for TMCL axis parameter 6 (motor run current) and 7 (motor standby current). They are used to set the run / standby current using the following TMCL commands:

```
SAP 6, 0, <value> // set run current
```

```
SAP 7, 0, <value> // set standby current
```

(read-out value with GAP instead of SAP. Please see separate TMCM-1140 firmware manual for further information)

**Motor current  $I_{RMS}$  [A]** Resulting motor current based on motor current setting

Motor current setting in software (TMCL)	Current scaling step (CS)	Motor current $I_{COIL\_PEAK}$ [A]	Motor current $I_{COIL\_RMS}$ [A]
0..7	0	0.092	0.065
8..15	1	0.184	0.130
16..23	2	0.276	0.195
24..31	3	0.368	0.260
32..39	4	0.460	0.326
40..47	5	0.552	0.391
48..55	6	0.645	0.456
56..63	7	0.737	0.521
64..71	8	0.829	0.586
72..79	9	0.921	0.651
80..87	10	1.013	0.716
88..95	11	1.105	0.781
96..103	12	1.197	0.846
104..111	13	1.289	0.912
112..119	14	1.381	0.977
120..127	15	1.473	1.042
128..135	16	1.565	1.107
136..143	17	1.657	1.172
144..151	18	1.749	1.237
152..159	19	1.842	1.302
160..167	20	1.934	1.367
168..175	21	2.026	1.432
176..183	22	2.118	1.497
184..191	23	2.210	1.563
192..199	24	2.302	1.628
200..207	25	2.394	1.693
208..215	26	2.486	1.758
216..223	27	2.578	1.823
224..231	28	2.670	1.888
232..239	29	2.762	1.953
240..247	30	2.854	2.018
248..255	31	2.946	2.083

Maximum current of the TCM-1140 driver electronics has been selected in order to meet the max. / rated current of the stepper motor which is part of the PD42-x-1140 PANdrive. Nevertheless, please monitor motor temperature in application – especially when selecting high current settings for longer time without cooling the motor appropriately. Motor temperature should not rise above 80°C in application. If the full current and full torque is required in combination with high duty cycles it is recommended to use a metal frame (aluminium etc.) for mounting the PANdrive™. This will help with distributing motor heat via stepper motor front flange.

In addition to the settings in the table the motor current may be switched off completely (free-wheeling) using axis parameter 204 (see TCM-1140 firmware manual).

## 6 Reset to Factory Defaults

It is possible to reset the PD42-x-1140 to factory default settings without establishing a communication link. This might be helpful in case communication parameters of the preferred interface have been set to unknown values or got accidentally lost.

For this procedure it is necessary to disassemble the PANdrive™ and shorten two pads on the bottom side of the printed circuit board (see Figure 6.1).

Please perform the following steps:

1. Power supply off and USB cable disconnected
2. Short two pads as marked in Figure 6.1
3. Power up board (power via USB is sufficient for this purpose)
4. Wait until the on-board red and green LEDs start flashing fast (this might take a while)
5. Power-off board (disconnect USB cable)
6. Remove short between pads
7. After switching on power-supply / connecting USB cable all permanent settings have been restored to factory defaults

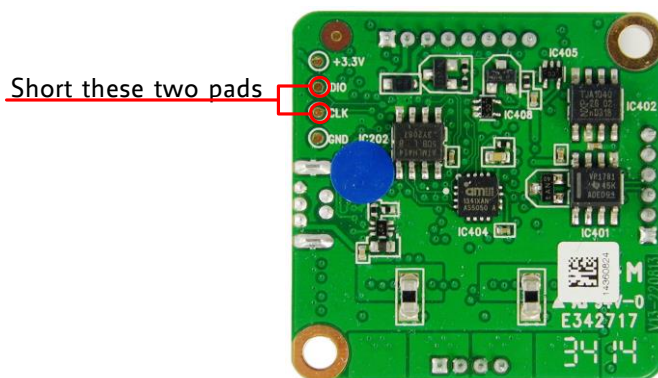


Figure 6.1 Reset to factory default settings

## 7 On-Board LEDs

The PANdrive™ offers two LEDs in order to indicate status. The function of both LEDs is dependent on the firmware version. With standard TMCL firmware the green LED should be flashing slowly during operation and the red LED should be off.

When there is no valid firmware programmed into the board or during firmware update the red and green LEDs are permanently on.

### BEHAVIOR OF LEDs WITH STANDARD TMCL FIRMWARE

Status	Label	Description
Heartbeat	Run	This green LED flashes slowly during operation.
Error	Error	This red LED lights up if an error occurs.

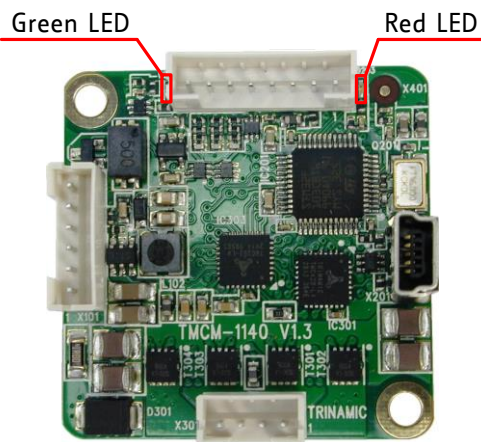


Figure 7.1 On-board LEDs

## 8 Operational ratings

The operational ratings show the intended or the characteristic ranges and should be used as design values.

***In no case shall the maximum values be exceeded!***

Symbol	Parameter	Min	Typ	Max	Unit
VDD	Power supply voltage for operation	9	12... 24	28	V
I <sub>COIL_peak</sub>	Motor coil current for sine wave <b>peak</b> (chopper regulated, adjustable via software)	0		2.8	A
I <sub>COIL_RMS</sub>	Continuous motor current ( <b>RMS</b> )	0		2.0	A
I <sub>DD</sub>	Power supply current		<< I <sub>COIL</sub>	1.4 * I <sub>COIL</sub>	A
T <sub>ENV</sub>	Environment temperature at rated current (no forced cooling required) <i>Motor temperature should not rise above 80°C in application</i>	-20		+50	°C

**Table 8.1 General operational ratings of module**

### OPERATIONAL RATINGS OF MULTIPURPOSE I/Os

Symbol	Parameter	Min	Typ	Max	Unit
V <sub>OUT_o</sub>	Voltage at open drain output OUT_o	0		+VDD	V
I <sub>OUT_o</sub>	Output sink current of open drain output OUT_o			1	A
V <sub>OUT_1</sub>	Voltage at output OUT_1 (when switched on)		+5		V
I <sub>OUT_1</sub>	Output source current for OUT_1			100	mA
V <sub>IN_1/2/3</sub>	Input voltage for IN_1, IN_2, IN_3 (digital inputs)	0		+VDD	V
V <sub>IN_L_1/2/3</sub>	Low level voltage for IN_1, IN_2 and IN_3	0		1.1	V
V <sub>IN_H_1/2/3</sub>	High level voltage for IN_1, IN_2 and IN_3	3.4		+VDD	V
V <sub>IN_o</sub>	Measurement range for analog input IN_o	0		+10*)	V

**Table 8.2 Operational ratings of multipurpose I/Os**

\*) approx. 0...+10.56V at the analog input IN\_o is translated to 0..4095 (12bit ADC, raw values). Above approx. +10.56V the analog input will saturate but, not being damaged (up-to VDD).

### OPERATIONAL RATINGS OF RS485 INTERFACE

Symbol	Parameter	Min	Typ	Max	Unit
N <sub>RS485</sub>	Number of nodes connected to single RS485 network			256	
f <sub>RS485</sub>	Maximum bit rate supported on RS485 connection		9600	115200 1000000*)	bit/s

**Table 8.3: Operational ratings of RS485 interface**

\*) TMC-1140 hardware revision V1.2: max. 115200 bit/s, TMC-1140 hardware revision V1.3: max. 1Mbit/s

**OPERATIONAL RATINGS OF CAN INTERFACE**

<b>Symbol</b>	<b>Parameter</b>	<b>Min</b>	<b>Typ</b>	<b>Max</b>	<b>Unit</b>
$N_{CAN}$	Number of nodes connected to single RS485 network			> 110	
$f_{CAN}$	Maximum bit rate supported on CAN connection		1000	1000	kbit/s

**Table 8.4 Operational ratings of the CAN interface**



## 9 Torque Curves

### 9.1.1 PD42-1-1140 Torque Curve



Figure 9.1 PD42-1-1140 torque vs. velocity 24V / 2A, 256µsteps

### 9.1.2 PD42-2-1140 Torque Curve

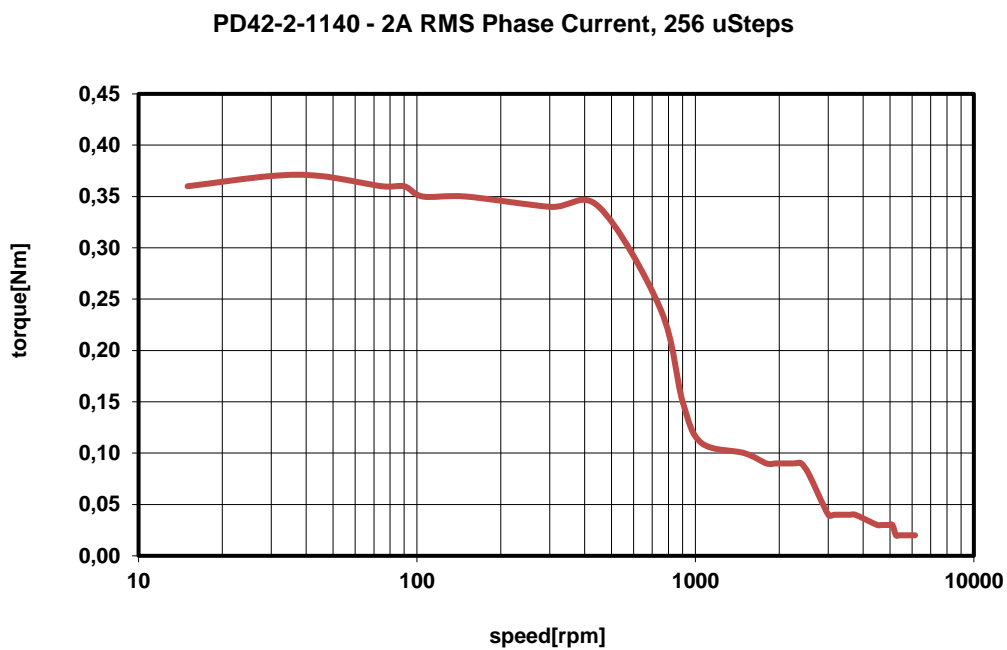


Figure 9.2 PD42-2-1140 torque vs. velocity 24V / 2A, 256µsteps

### 9.1.3 PD42-3-1140 Torque Curve

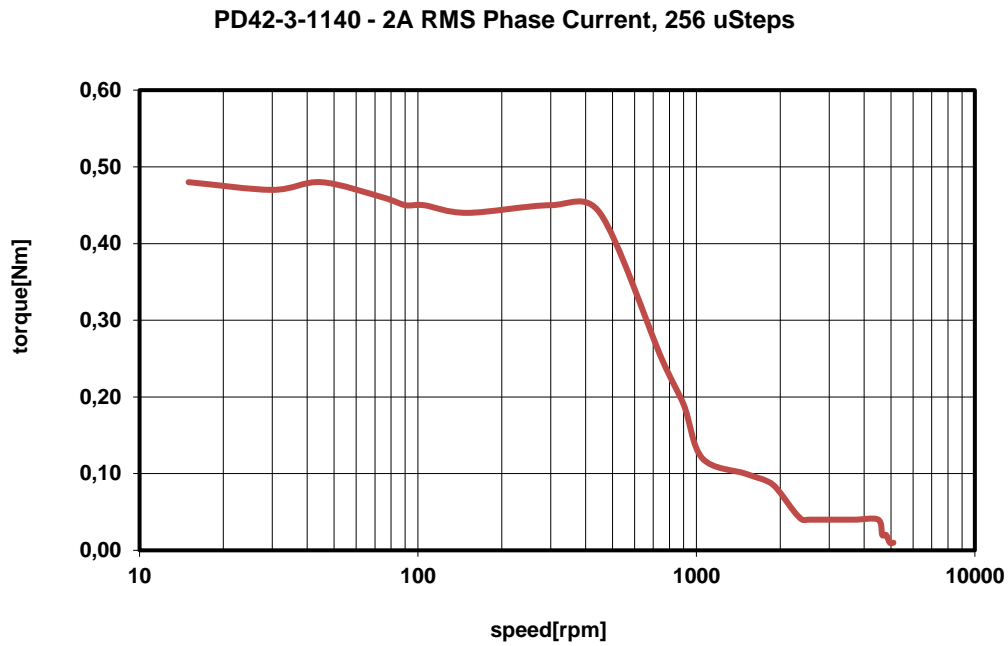


Figure 9.3 PD42-3-1140 torque vs. velocity 24V / 2A, 256µsteps

### 9.1.4 PD42-4-1140 Torque Curve

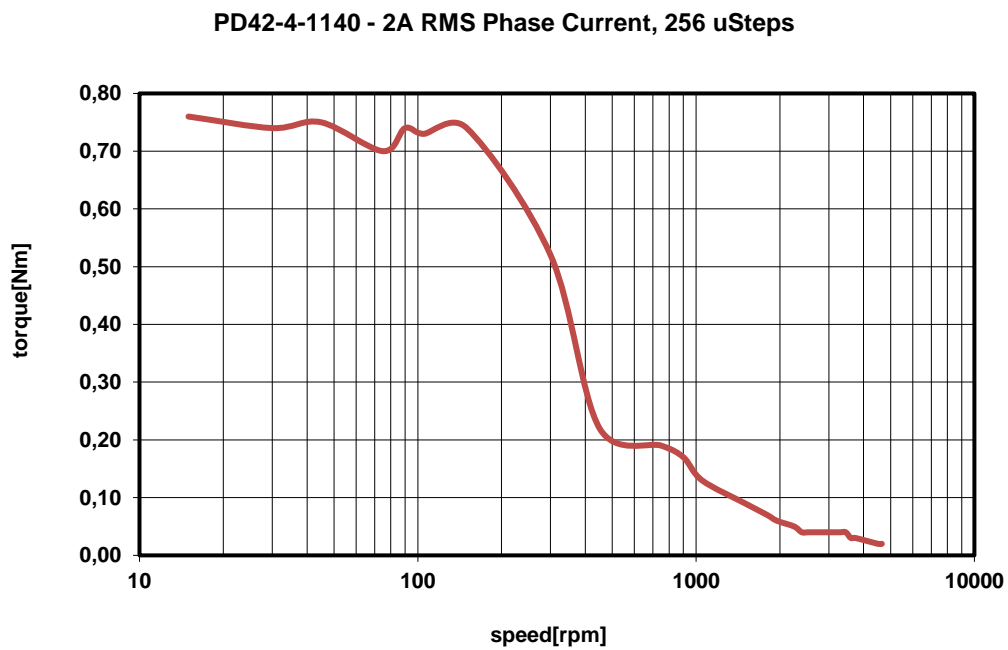


Figure 9.4 PD42-4-1140 torque vs. velocity 24V / 2A, 256µsteps

## 10 Functional description

The PD42-x-1140 is a full mechatronic solution including a 42mm flange (NEMA17) bipolar stepper motor. It includes the controller / driver electronics TCMC-1140 and a choice between four different NEMA 17 / 42mm flange size bipolar hybrid stepper motors with different length and torque.

The PD42-x-1140 can be controlled via USB, RS485 or CAN serial interfaces. There are three general purpose digital inputs which can be used, also as STOP\_L / STOP\_R / HOME switch inputs (for reference movements, as end switches etc. depending on firmware, mode and configuration) or for connecting an additional external encoder (incremental A/B/N). In addition, there is one dedicated analog input for 0..+10V analog signals and two general-purpose outputs (one open-drain and one switchable +5V supply output).

The PD42-x-1140 with TMCL™ firmware option is supported by the PC based software development environment TMCL-IDE for the Trinamic Motion Control Language (TMCL™). Using predefined TMCL™ high level commands like *move to position* a rapid and fast development of motion control applications is guaranteed. Please refer to the PD42-x-1140 or TCMC-1140 firmware manuals for more information about TMCL™ commands.

Communication traffic is kept low since all time critical operations, e.g. ramp calculation are performed on board. Complete stand-alone or full remote control or anything in-between is possible. The firmware of the module can be updated via the serial interface.

As an alternative to TMCL, a CANopen firmware is available.

In Figure 10.1 the main parts of the PD42-x-1140 are shown:

- microcontroller, which runs the TMCL script language interpreter (connected to TMCL memory),
- dedicated motion controller, which calculates ramps and speed profiles in hardware,
- pre-driver with stallGuard2™ and its energy efficient coolStep™ feature,
- MOSFET driver stage,
- NEMA17 / 42mm flange size bipolar hybrid stepper motor
- sensOstep™ encoder with resolutions of 10bit (1024 steps) per revolution.

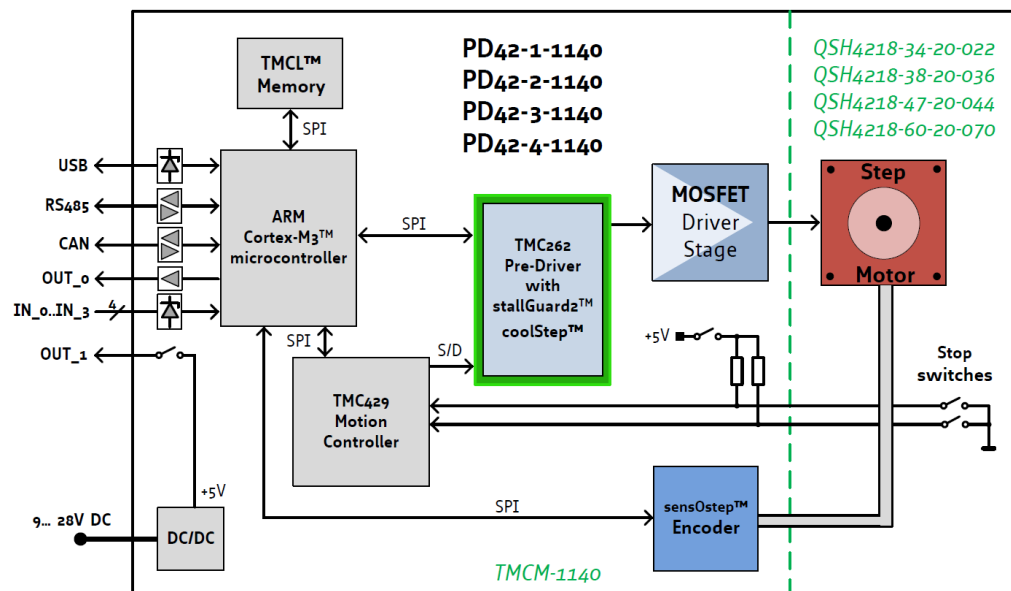


Figure 10.1: Main parts of PD42-x-1140

## 11 PD42-x-1140 Operational Description

### 11.1 Calculation: Velocity and Acceleration vs. Microstep and Fullstep Frequency

The values of the parameters sent to the motion controller TMC429 integrated on the PD42-x-1140 PANdrive do not have typical motor values like rotations per second as velocity. But these values can be calculated from the TMC429 parameters as shown in this section.

#### PARAMETERS OF TMC429

Signal	Description	Range
f <sub>CLK</sub>	clock-frequency	16 MHz
velocity	-	0... 2047
a <sub>max</sub>	maximum acceleration	0... 2047
pulse_div	divider for the velocity. The higher the value is, the less is the maximum velocity default value = 0	0... 13
ramp_div	divider for the acceleration. The higher the value is, the less is the maximum acceleration default value = 0	0... 13
Usrs	microstep-resolution (microsteps per fullstep = 2 <sup>usrs</sup> )	0... 8

**Table 11.1 TMC429 velocity parameters**

#### MICROSTEP FREQUENCY

The microstep frequency of the stepper motor is calculated with

$$usf[Hz] = \frac{f_{CLK}[Hz] \cdot velocity}{2^{pulse\_div} \cdot 2048 \cdot 32} \quad \text{with usf: microstep-frequency}$$

#### FULLSTEP FREQUENCY

To calculate the fullstep frequency from the microstep frequency, the microstep frequency must be divided by the number of microsteps per fullstep.

$$fsf[Hz] = \frac{usf[Hz]}{2^{usrs}} \quad \text{with fsf: fullstep-frequency}$$

The change in the pulse rate per time unit (pulse frequency change per second – the **acceleration a**) is given by

$$a = \frac{f_{CLK}^2 \cdot a_{max}}{2^{pulse\_div+ramp\_div+29}}$$

This results in acceleration in fullsteps of:

$$af = \frac{a}{2^{usrs}} \quad \text{with af: acceleration in fullsteps}$$

**EXAMPLE**

Signal	value
f_CLK	16 MHz
velocity	1000
a_max	1000
pulse_div	1
ramp_div	1
usrs	6

$$msf = \frac{16 \text{ MHz} \cdot 1000}{2^1 \cdot 2048 \cdot 32} = \underline{\underline{122070.31 \text{ Hz}}}$$

$$fsf[\text{Hz}] = \frac{122070.31}{2^6} = \underline{\underline{1907.34 \text{ Hz}}}$$

$$a = \frac{(16 \text{ MHz})^2 \cdot 1000}{2^{1+1+29}} = \underline{\underline{119.21 \frac{\text{MHz}}{\text{s}}}}$$

$$af = \frac{119.21 \frac{\text{MHz}}{\text{s}}}{2^6} = \underline{\underline{1.863 \frac{\text{MHz}}{\text{s}}}}$$

**CALCULATION OF THE NUMBER OF ROTATIONS**

A stepper motor has e.g. 72 fullsteps per rotation.

$$RPS = \frac{fsf}{\text{fullsteps per rotation}} = \frac{1907.34}{72} = 26.49$$

$$RPM = \frac{fsf \cdot 60}{\text{fullsteps per rotation}} = \frac{1907.34 \cdot 60}{72} = 1589.46$$

## 12 Revision history

### 12.1 Document revision

Version	Date	Author	Description
0.90	2011-DEC-22	GE	Initial version
0.91	2012-MAY-02	GE	Updated for TCMC-1140_V11 pcb version
1.00	2012-JUN-26	SD	First complete version including the following chapters: <ul style="list-style-type: none"> <li>- Reset to factory defaults</li> <li>- LEDs</li> <li>- Torque curves</li> </ul>
1.01	2012-JUL-30	SD	Internal circuit of inputs corrected.
1.02	2013-MAR-26	SD	Names of inputs changed: <del>AIN_0</del> IN_0 <del>IN_0</del> IN_1 <del>IN_1</del> IN_2 <del>IN_2</del> IN_3 Names of outputs changed: OUT_1 = OUT_0 OUT_0 = OUT_1
1.03	2018-JAN-25	GE	Major update: <ul style="list-style-type: none"> <li>- Integration of updated and new chapters from TCMC-1140 hardware manual</li> <li>- Note on sensOstep™ encoder accuracy added</li> <li>- More Details + tolerances added to motor shaft drawing</li> </ul>

Figure 12.1: Document revision

### 12.2 Hardware revision

Please note: all current PD42-1-1140, PD42-2-1140, PD42-2-1140 and PD42-4-1140 PANdrives™ use controller driver electronics TCMC-1140 V1.3. Previous versions used TCMC-1140 V1.2. All other TCMC-1140 hardware versions listed below have been used for prototypes, only. The following list includes changes in hardware for the TCMC-1140 controller / driver electronics since initial hardware (prototype) version V1.0:

Version	Date	Description
TCMC-1040_V10*)	2011-MAR-08	Initial version
TCMC-1140_V11*)	2011-JUL-19	<ul style="list-style-type: none"> <li>- Optimization of multipurpose I/O circuits</li> <li>- Clock generation and distribution changed (16MHz oscillator)</li> </ul>
TCMC-1140_V12**)	2012-APR-12	<ul style="list-style-type: none"> <li>- Further cost optimization incl. different sensor IC with 10bit max. resolution</li> </ul>
TCMC-1140_V13**)	2013-AUG-22	<ul style="list-style-type: none"> <li>- Stepper motor driver MOSFETs: The MOSFETs of the driver stage have been replaced. The new MOSFETs offer less heat dissipation than the previously used ones. Apart from that the performance and settings including driver output current and output waveform are essentially the same.</li> <li>- General purpose outputs OUT_0 / OUT_1: The MOSFETs used for switching these outputs on / off have been replaced. The new MOSFETs offer less heat dissipation than the previous / currently used ones. Apart from that the functionality and ratings are essentially the same.</li> <li>- RS485 transceiver: the RS485 transceiver has been replaced with the SN65HVD1781 transceiver offering better</li> </ul>

Version	Date	Description
		fault protection (up-to 70V fault protection) and supporting higher communication speeds (up-to 1Mbit/s). - Conformal coating of both sides of the PCB. Provides improved protection against humidity and dust / swarf (e.g. in case of the motor mounted versions PD42-x-1140: tiny metal parts on the PCB attracted by the encoder magnet might lead to malfunction of the unprotected device).

**Table 12.1 Hardware revision**

\*) *V10, V11: prototypes only.*

\*\*) *V12: series product version. Is replaced with V13 series product version due to EOL (end-of-life) of MOSFETs. Please see "PCN\_1014\_08\_29\_TMCM-1140.pdf" on our Web-site, also*

## 13 References

[JST]	JST PH connector (2.0mm pitch, disconnectable crimp style) <a href="http://www.jst.com">http://www.jst.com</a>
[USB-2-485]	USB-2-485 interface converter Additional information can be found on <a href="http://www.trinamic.com">http://www.trinamic.com</a> .
[TMC429]	TMC429 datasheet Additional information can be found on <a href="http://www.trinamic.com">http://www.trinamic.com</a> .
[TMC262]	TMC262 datasheet Additional information can be found on <a href="http://www.trinamic.com">http://www.trinamic.com</a> .

## X-ON Electronics

Largest Supplier of Electrical and Electronic Components

*Click to view similar products for [Stepper Motors](#) category:*

*Click to view products by [Analog Devices](#) manufacturer:*

Other Similar products are found below :

[HT17-275](#) [5014-020](#) [HT17-271D](#) [82924041](#) [82924036](#) [82914016](#) [80910502](#) [80910501](#) [80910003](#) [HT23-598](#) [HT08-221](#) [902-0135-000](#)  
[MS11HS3P4067-09RL](#) [MS17HD6P4200-24RL](#) [MS11HS5P4150-13RL](#) [MS08HY1P4050-09RL](#) [MS08HY3P4050-02RL](#) [ML24HCAL3550-01RL](#) [MS17HD6P4100-16RL](#) [ML23HS8P4220-16RL](#) [MS17HD2P4200-20RL](#) [ML23HSAL4500-E](#) [MS14HS5P4100-03RL](#) [MS17HD2P4100-27RL](#) [MS14HS1P4100-09RL](#) [MS11HS1P4100-25RL](#) [ML23HSAP4300-18RL](#) [ML23HS4P4100-02RL](#) [PL23HS8L4550-05RL](#)  
[PL23HSAL4500-05RL](#) [MS17HD4P4150-22RL](#) [PM42S-048-HHC8](#) [PM20L-020-HHC3](#) [PM42L-048-HHC9](#) [82930002](#) [HT34-504](#) [82910003](#)  
[103H7823-0440](#) [103H7126-0440](#) [103H8223-5141](#) [103H8223-6340](#) [103H7126-0740](#) [103H7126-5740](#) [103H7822-5740](#) [STEPPER MOTOR BIPOLAR 42X38MM 2.8V 1.7A](#) [SY20STH30-0604A](#) [STEPPER MOTOR: UNIPOLAR/BIPOLAR 57Å—56MM](#) [ROB-10551](#) [STEPPER MOTOR: UNIPOLAR/BIPOLAR 57Å—76MM](#) [103H7123-5740](#)