

TMC4671 Datasheet

IC Version V1.3 | Document Revision V2.02 • 2020-Oct-08

The TMC4671 is a fully integrated servo controller, providing Field Oriented Control for BLDC/PMSM and 2-phase Stepper Motors as well as DC motors and voice coils. All control functions are implemented in hardware. Integrated ADCs, position sensor interfaces, position interpolators, enable a fully functional servo controller for a wide range of servo applications.

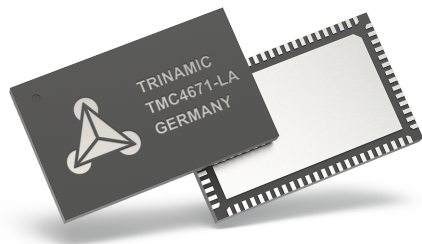

Features

- Servo Controller w/ Field Oriented Control (FOC)
- Torque Control (FOC), Velocity Control, Position Control
- Integrated ADCs, $\Delta\Sigma$ -ADC Frontend
- Encoder Engine: Hall analog/digital, Encoder analog/digital
- Supports 3-Phase PMSM/BLDC, 2-Phase Stepper Motors, and 1-Phase DC Motors
- Fast PWM Engine (25kHz ... 100kHz)
- Application SPI + Debug (UART, SPI)
- Step-Direction Interface (S/D)

Applications

- Robotics
- Pick and Place Machines
- Factory Automation
- E-Mobility
- Laboratory Automation
- Blowers
- Pumps

Simplified Block Diagram

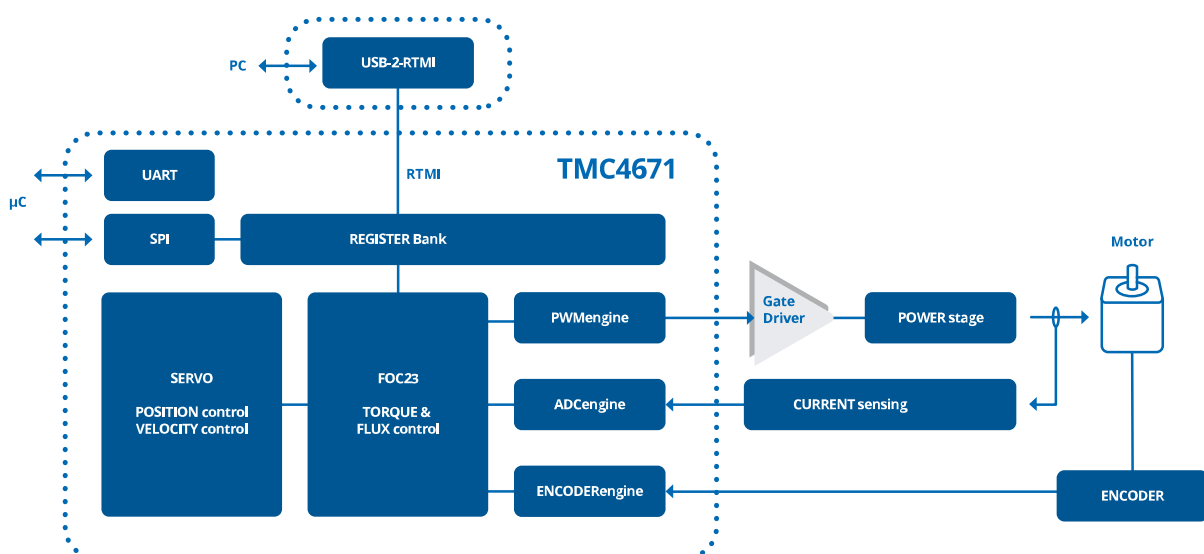

Contents

1	Order Codes	6
2	Functional Summary	7
3	FOC Basics	9
3.1	Why FOC?	9
3.2	What is FOC?	9
3.3	Why FOC as pure Hardware Solution?	9
3.4	How does FOC work?	10
3.5	What is Required for FOC?	10
3.5.1	Coordinate Transformations - Clarke, Park, iClarke, iPark	11
3.5.2	Measurement of Stator Coil Currents	11
3.5.3	Stator Coil Currents I _U , I _V , I _W and Association to Terminal Voltages U _U , U _V , U _W	11
3.5.4	I _{gain} ADC[A/LSB] - ADC Integer Current Value to Real World Unit	12
3.5.5	U _{gain} ADC[V/LSB] - ADC Integer Voltage Value to Real World Unit	12
3.5.6	Measurement of Rotor Angle	12
3.5.7	Measured Rotor Angle vs. Magnetic Axis of Rotor vs. Magnetic Axis of Stator	12
3.5.8	Knowledge of Relevant Motor Parameters and Position Sensor (Encoder) Parameters	13
3.5.9	Proportional Integral (PI) Controllers for Closed Loop Current Control	14
3.5.10	Pulse Width Modulation (PWM) and Space Vector Pulse Width Modulation (SVPWM)	14
3.5.11	Orientations, Models of Motors, and Coordinate Transformations	15
4	Functional Description	16
4.1	Functional Blocks	16
4.2	Communication Interfaces	17
4.2.1	SPI Slave User Interface	17
4.2.2	TRINAMIC Real-Time Monitoring Interface (SPI Master)	20
4.2.3	UART Interface	21
4.2.4	Step/Direction Interface	22
4.2.5	Single Pin Interface	22
4.2.6	GPIO Interface	23
4.3	Numerical Representation, Electrical Angle, Mechanical Angle, and Pole Pairs	24
4.3.1	Numerical Representation	24
4.3.2	N_POLE_PAIRS, PHI_E, PHI_M	25
4.3.3	Numerical Representation of Angles PHI	26
4.4	ADC Engine	28
4.4.1	ADC current sensing channels ADC_I1 and ADC_I0	28
4.4.2	ADC for analog Hall signals or analog sin-cos-encoders AENC_UX, AENC_VN, AENC_WY	28
4.4.3	ADC supply voltage measurement ADC_VM	28
4.4.4	ADC_VM for Brake Chopper	29
4.4.5	ADC EXT register option	29
4.4.6	ADC general purpose analog inputs AGPI_A and AGPI_B	29
4.4.7	ADC RAW values	29
4.4.8	ADC_SCALE and ADC_OFFSET	29
4.4.9	ADC Gain Factors for Real World Values	29
4.4.10	Internal Delta Sigma ADCs	30
4.4.11	Internal Delta Sigma ADC Input Stage Configuration	30
4.4.12	External Delta Sigma ADCs	32
4.4.13	ADC Group A and ADC Group B	32
4.4.14	Delta Sigma Configuration and Timing Configuration	32
4.4.15	Internal Delta Sigma Modulators - Mapping of V_RAW to ADC_RAW	36



4.4.16	External Delta Sigma Modulator Interface	37
4.5	Analog Signal Conditioning	39
4.5.1	FOC3 - Stator Coil Currents I_U, I_V, I_W and associated Voltages U_U, U_V, U_W	39
4.5.2	FOC2 - Stepper Coil Currents I_X, I_Y and associated Voltages U_X, U_Y	40
4.5.3	FOC1 - DC Motor Coil Current I_{X1}, I_{X2} , and associated Voltage U_{X1}, U_{X2}	40
4.5.4	ADC Selector & ADC Scaler w/ Offset Correction	41
4.6	Encoder Engine	42
4.6.1	Open-Loop Encoder	42
4.6.2	Incremental ABN Encoder	43
4.6.3	Secondary Incremental ABN Encoder	45
4.6.4	Digital Hall Sensor Interface with optional Interim Position Interpolation	45
4.6.5	Digital Hall Sensor - Interim Position Interpolation	46
4.6.6	Digital Hall Sensors - Masking, Filtering, and PWM center sampling	46
4.6.7	Digital Hall Sensors together with Incremental Encoder	48
4.6.8	Analog Hall and Analog Encoder Interface (SinCos of $0^\circ 90^\circ$ or $0^\circ 120^\circ 240^\circ$)	48
4.6.9	Analog Position Decoder (SinCos of $0^\circ 90^\circ$ or $0^\circ 120^\circ 240^\circ$)	49
4.6.10	Encoder Initialization Support	50
4.6.11	Velocity Measurement	50
4.6.12	Reference Switches	51
4.7	FOC23 Engine	52
4.7.1	ENI and ENO pins	52
4.7.2	PI Controllers	52
4.7.3	PI Controller Calculations - Classic Structure	52
4.7.4	PI Controller Calculations - Advanced Structure	54
4.7.5	PI Controller - Clipping	55
4.7.6	PI Flux & PI Torque Controller	56
4.7.7	PI Velocity Controller	56
4.7.8	P Position Controller	57
4.7.9	Inner FOC Control Loop - Flux & Torque	57
4.7.10	FOC Transformations and PI(D) for control of Flux & Torque	57
4.7.11	Motion Modes	58
4.7.12	Brake Chopper	59
4.8	Filtering and Feed-Forward Control	60
4.8.1	Biquad Filters	60
4.8.2	Standard Velocity Filter	61
4.8.3	Feed-Forward Control Structure	61
4.9	PWM Engine	62
4.9.1	PWM Polarities	62
4.9.2	PWM Engine and associated Motor Connectors	63
4.9.3	PWM Frequency	64
4.9.4	PWM Resolution	64
4.9.5	PWM Modes	64
4.9.6	Break-Before-Make (BBM)	64
4.9.7	Space Vector PWM (SVPWM)	65
4.9.8	Real- and Integer-Conversions	65
5	Safety Functions	66
6	FOC Setup - How to Turn a Motor	69
6.1	Select Motor Type	69
6.1.1	FOC1 Setup - How to Turn a Single Phase DC Motor	69
6.1.2	FOC2 Setup - How to Turn a Two Phase Motor (Stepper)	69
6.1.3	FOC3 Setup - How to Turn a Three Phase Motor (PMSM or BLDC)	69
6.2	Set Number of Pole Pairs (NPP)	69



6.3	Run Motor Open Loop	70
6.3.1	Determination of Association between Phase Voltage and Phase Currents	70
6.3.2	Determination of Direction of Rotation and Phase Shift of Angles	70
6.4	Selection of Position Sensors	70
6.4.1	Selection of FOC sensor for PHI_E	70
6.4.2	Selection of sensor for VELOCITY	70
6.4.3	Selection of sensor for POSITION	70
6.5	Modes of Operation - (Open Loop), Torque, Velocity, Positioning	71
6.6	Controller Tuning	71
7	Register Map	71
7.1	Register Map - Overview	72
7.2	Register Map - Functional Description	76
7.3	Register Map - Defaults, Data Fields (Bit Masks), min, max	110
8	Pinning	128
9	TMC4671 Pin Table	130
10	Electrical Characteristics	134
10.1	Absolute Maximum Ratings	134
10.2	Electrical Characteristics	134
10.2.1	Operational Range	134
10.2.2	DC Characteristics	135
11	Sample Circuits	136
11.1	Supply Pins	136
11.2	Clock and Reset Circuitry	136
11.3	Digital Encoder, Hall Sensor Interface and Reference Switches	136
11.4	Analog Frontend	137
11.5	Phase Current Measurement	137
11.6	Power Stage Interface	139
12	Setup Guidelines	140
13	Package Dimensions	141
14	Supplemental Directives	144
14.1	Producer Information	144
14.2	Copyright	144
14.3	Trademark Designations and Symbols	144
14.4	Target User	144
14.5	Disclaimer: Life Support Systems	144
14.6	Disclaimer: Intended Use	144
14.7	Collateral Documents & Tools	145
15	Fixes of TMC4671-LA/-ES2 vs. Errata of TMC4671-ES	146
15.1	Errata of TMC4671-ES Engineering Samples as Reference	146
15.2	Actions to Avoid Trouble	147
15.3	Recommendations	147
16	Figures Index	148
17	Tables Index	149



18 Revision History	150
18.1 IC Revision	150
18.2 Document Revision	150



1 Order Codes

Order Code	Description	Size
TMC4671-LA	TMC4671 FOC Servo Controller IC	10.5mm x 6.5mm
TMC4671-ES2	TMC4671-LA 1936 35735 (Engineering Sample)	10.5mm x 6.5mm
TMC4671-EVAL	TMC4671 Evaluation Board	55mm x 85mm
TMC4671-BOB	TMC4671 Breakout Board	38mm x 40mm
Landungsbruecke	MCU Board	85mm x 55mm
TMC-UPS-2A24V-A-EVAL	Power Stage Board	85mm x 55mm
TMC-UPS-10A70V-A-EVAL	Power Stage Board	85mm x 55mm
TMC4671+TMC-UPS-2A24V-EVAL-KIT	Evaluation Kit	—
TMC4671+TMC-UPS-10A70V-EVAL-KIT	Evaluation Kit	—
USB-2-RTMI	Interface Adapter to use RTMI	40mm x 20mm

Table 1: Order codes

Note

TMC4671-ES2 labeled TMC4671-LA 1936 35735 are pre-series production engineering samples for evaluation of final silicone functionality of the TMC4671-LA.



2 Functional Summary

- **Servo Controller with Field Oriented Control (FOC)**
 - Torque (and flux) control mode
 - Velocity control mode
 - Position control mode
- **Control Functions/PI Controllers**
 - Programmable clipping of inputs and outputs of interim results
 - Integrator windup protection for all controllers
 - Status output with programmable mask for internal status signal selection
- **Supported Motor Types**
 - FOC3 : 3-phase permanent magnet synchronous motors (PMSM) / brushless DC motor (BLDC)
 - FOC2 : 2-phase stepper motors
 - FOC1 : 1-phase brushed DC motors, or linear voice coil motors
- **ADC Engine with Offset Correction and Scaling**
 - Integrated Delta Sigma ADCs for current sense voltage, supply voltage, analog encoder, AGPIs
 - Interface for isolated external current sensing Delta Sigma modulators
- **Position Feedback**
 - Open loop position generator (programmable [rpm], [rpm/s]) for initial setup
 - Digital incremental encoder (ABN resp. ABZ, up to 2 MHz)
 - Secondary digital incremental encoder
 - Digital Hall sensor interface (H1, H2, H3 resp. H_U, H_V, H_W) with interim position interpolation
 - Analog encoder/analog Hall sensor interface (SinCos (0°, 90°) or 0°, 120°, 240°)
 - Position target, velocity and target torque filters (Biquad)
 - multi-turn position counter (32-bit)
- **PWM Engine Including SVPWM**
 - Programmable PWM frequency within the range of 25 kHz ... 100 kHz
 - PWM auto scaling for transparent change of PWM frequency during motion
 - Programmable Brake-Before-Make (BBM) times (0 ns ... 2.5 μ s) for digital gate control signals
 - Single bit SVPWM control (on/off) for Space Vector Modulation (switchable during operation)



- **SPI Application Communication Interface**

- 40 bit datagram length (1 ReadWrite bit + 7 address bits + 32 data bits)
- Immediate SPI read response (register read access by single datagram)
- SPI clock frequency fSCK up to 2 MHz (8 MHz write, 8 MHz read w/ 500 ns pause after address)

- **TRINAMIC Real Time Monitoring Interface**

- High frequency sampling of real-time data via TRINAMIC's real-time monitoring system
- Only single 10 pin high density connector on PCB needed
- Enables frequency response identification and auto tuning options with TRINAMIC's IDE

- **UART Debug Interface**

- Three pin (GND, RxD, TxD) 3.3 V UART interface (1N8; 9600 (default), 115200, 921600, 3M bps)
- Available as port for external position sensors (e.g. absolute encoder together with processor)
- Transparent register access parallel to embedded user application interface (SPI)

- **Supply Voltages**

- 5V and 3.3V; VCC_CORE is internally generated

- **IO Voltage**

- 3.3V for all digital IOs (choosable by VCCIO Supply)
- 5V common mode analog input voltage range (1.25V ... 2.5V differential operating range)

- **Clock Frequency**

- 25 MHz (from external oscillator)

- **Packages**

- QFN76



3 FOC Basics

This section gives a short introduction into some basics of Field Oriented Control (FOC) of electric motors.

3.1 Why FOC?

The Field Oriented Control (FOC), alternatively named Vector Control (VC), is a method for the most energy-efficient way of turning an electric motor.

3.2 What is FOC?

The Field Oriented Control was independently developed by K. Hasse, TU Darmstadt, 1968, and by Felix Blaschke, TU Braunschweig, 1973. The FOC is a current regulation scheme for electro motors that takes the orientation of the magnetic field and the position of the rotor of the motor into account, regulating the strength in such way that the motor gives that amount of torque that is requested as target torque. The FOC maximizes active power and minimizes idle power - that finally results in power dissipation - by intelligent closed-loop control illustrated by figure 1.

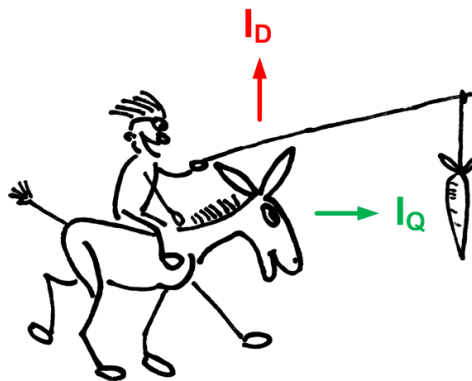

Figure 1: Illustration of the FOC basic principle by cartoon: Maximize active power and minimize idle power and power dissipation by intelligent closed-loop control.

3.3 Why FOC as pure Hardware Solution?

The initial setup of the FOC is usually very time consuming and complex, although source code is freely available for various processors. This is because the FOC has many degrees of freedom that all need to fit together in a chain in order to work.

The hardware FOC as an existing standard building block drastically reduces the effort in system setup. With that off the shelf building block, the starting point of FOC is the setup of the parameters for the FOC. Setting up and implement the FOC itself and building and programming required interface blocks is no longer necessary. The real parallel processing of hardware blocks de-couples the higher lever application software from high speed real-time tasks and simplifies the development of application software. With the TMC4671, the user is free to use its qualified CPU together with its qualified tool chain, freeing the user from fighting with processer-specific challenges concerning interrupt handling and direct memory access. There is no need for a dedicated tool chain to access the TMC4671 registers and to operate it - just SPI (or UART) communication needs to be enabled for any given CPU.

The hardware integration of the FOC drastically reduces the number of required components and reduces the required PCB space. This is in contrast to classical FOC servos formed by motor block and separate



controller box wired with motor cable and encoder cable. The high integration of FOC, together with velocity controller and position controller, enables the FOC as a standard peripheral component that transforms digital information into physical motion. Compact size together with high performance and energy efficiency especially for battery powered mobile systems are enabling factors when embedded goes autonomous.

3.4 How does FOC work?

Two force components act on the rotor of an electric motor. One component is just pulling in radial direction (I_D) where the other component is applying torque by pulling tangentially (I_Q). The ideal FOC performs a closed loop current control that results in a pure torque generating current I_Q – without direct current I_D .

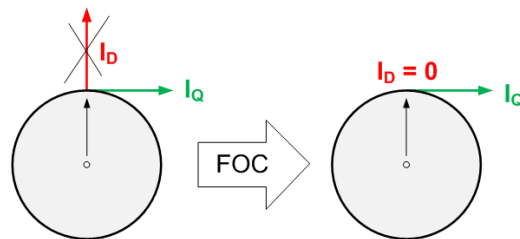

Figure 2: FOC optimizes torque by closed loop control while maximizing I_Q and minimizing I_D to 0

From top point of view, the FOC for 3-phase motors uses three phase currents of the stator interpreted as a current vector (I_u ; I_v ; I_w) and calculates three voltages interpreted as a voltage vector (U_u ; U_v ; U_w) taking the orientation of the rotor into account in a way that only a torque generating current I_Q results.

From top point of view, the FOC for 2-phase motors uses two phase currents of the stator interpreted as a current vector (I_x ; I_y) and calculates two voltages interpreted as a voltage vector (U_x ; U_y) taking the orientation of the rotor into account in a way that only a torque generating current I_Q results.

To do so, the knowledge of some static parameters (number of pole pairs of the motor, number of pulses per revolution of an used encoder, orientation of encoder relative to magnetic axis of the rotor, count direction of the encoder) is required together with some dynamic parameters (phase currents, orientation of the rotor).

The adjustment of P parameter P and I parameters of two PI controllers for closed loop control of the phase currents depends on electrical parameters of the motor (resistance, inductance, back EMF constant of the motor that is also the torque constant of the motor, supply voltage).

3.5 What is Required for FOC?

The FOC needs to know the direction of the magnetic axis of the rotor of the motor in reference to the magnetic axis of the stator of the motor. The magnetic flux of the stator is calculated from the currents through the phases of the motor. The magnetic flux of the rotor is fixed to the rotor and thereby determined by an encoder device.

For the FOC, the user needs to measure the currents through the coils of the stator and the angle of the rotor. The measured angle of the rotor needs to be adjusted to the magnetic axes.

The challenge of the FOC is the high number of degrees of freedom in all parameters.



3.5.1 Coordinate Transformations - Clarke, Park, iClarke, iPark

The FOC requires different coordinate transformations formulated as a set of matrix multiplications. These are the Clarke Transformation (Clarke), the Park Transformation (Park), the inverse Park Transformation (iPark) and the inverse Clarke Transformation (iClarke). The Park transformation is also known as DQ transformation, whereas the Clarke transformation is known as $\alpha\beta$ transformation.

The TMC4671 takes care of the required transformations so the user no longer has to fight with implementation details of these transformations.

3.5.2 Measurement of Stator Coil Currents

The measurement of the stator coil currents is required for the FOC to calculate a magnetic axis out of the stator field caused by the currents flowing through the stator coils.

Coil current stands for motor torque in context of FOC. This is because motor torque is proportional to motor current, defined by the torque constant of a motor. In addition, the torque depends on the orientation of the rotor of the motor relative to the magnetic field produced by the current through the coils of the stator of the motor.

3.5.3 Stator Coil Currents I_U, I_V, I_W and Association to Terminal Voltages U_U, U_V, U_W

The correct association between stator terminal voltages U_U, U_V, U_W and stator coil currents I_U, I_V, I_W is essential for the FOC. In addition to the association, the signs of each current channel need to fit. Signs of the current can be adapted numerically by the ADC scaler. The mapping of ADC channels is programmable via configuration registers for the ADC selector. Initial setup is supported by the integrated open loop encoder block, that can support the user to turn a motor open loop.

3.5.3.1 Chain of Gains for ADC Raw Values

An ADC raw value is a result of a chain of gains that determine it. A coil current I_SENSE flowing through a sense resistor causes a voltage difference according to Ohm's law. The resulting ADC raw value is a result of the analog signal path according to

$$\text{ADC_RAW} = (\text{I_SENSE} * \text{ADC_GAIN}) + \text{ADC_OFFSET}. \quad (1)$$

The ADC_GAIN is a result of a chain of gains with individual signs. The sign of the ADC_GAIN is positive or negative, depending on the association of connections between sense amplifier inputs and the sense resistor terminals. The ADC_OFFSET is the result of electrical offsets of the phase current measurement signal path. For the TMC4671, the maximum ADC_RAW value $\text{ADC_RAW_MAX} = (2^{16} - 1)$ and the minimum ADC raw value is $\text{ADC_RAW_MIN} = 0$.

$$\begin{aligned} \text{ADC_GAIN} = & \quad (\quad \text{I_SENSE_MAX} * \text{R_SENSE} \quad) \\ & * \quad \text{SENSE_AMPLIFIER_GAIN} \quad (2) \\ & * \quad (\quad \text{ADC_RAW_MAX}/\text{ADC_U_MAX} \quad) \end{aligned}$$

For the FOC, the ADC_RAW is scaled by the ADC scaler of the TMC4671 together with subtraction of offset to compensate it. Internally, the TMC4671 FOC engine calculates with s16 values. Thus, the ADC scaling needs to be chosen so that the measured currents fit into the s16 range. With the ADC scaler, the user can choose a scaling with physical units like [mA].



3.5.4 I_{gain}ADC[A/LSB] - ADC Integer Current Value to Real World Unit

Together with ADC_I0_SCALE and ADC_I0_OFFSET and ADC_I1_SCALE and ADC_I1_OFFSET, measured ADC currents represented as 16 bit signed interger numbers (s16) represent real world currents. Multiplication of integer current value with gain scaling factor in unit Ampere per LSB (Low Significant Bit) gives the real world value of current in unit Ampere.

$$\begin{aligned} I_0[A] &= I_{\text{gainADC}[A/LSB]} * \text{ADC_I0} \\ I_1[A] &= I_{\text{gainADC}[A/LSB]} * \text{ADC_I1} \end{aligned} \quad (3)$$

Different scalings between two associated current ADC channels can be trimmed by programing ADC_I0_SCALE and ADC_I1_SCALE. The I_{gain}ADC[A/LSB] needs to be determined from ADC gain factors, ADC reference voltage selection, and actual ADC scaling factor settings.

3.5.5 U_{gain}ADC[V/LSB] - ADC Integer Voltage Value to Real World Unit

Measured ADC voltages represented as 16 bit signed interger numbers (s16) represent real world voltages. Multiplication of integer voltage value with gain scaling factor in unit Volt per LSB (Low Significant Bit) gives the real world value of voltage in unit Volt.

$$U[V] = U_{\text{gainADC}[V/LSB]} * \text{ADC_U} \quad (4)$$

The U_{gain}ADC[V/LSB] needs to be determined from ADC gain factors, actual ADC gains, and ADC reference voltage settings.

3.5.6 Measurement of Rotor Angle

Determination of the rotor angle is either done by sensors (digital encoder, analog encoder, digital Hall sensors, analog Hall sensors) or sensorless by a reconstruction of the rotor angle. Currently, there are no sensorless methods available for FOC that work in a general purpose way as a sensor down to velocity zero.

The TMC4671 does not support sensorless FOC.

3.5.7 Measured Rotor Angle vs. Magnetic Axis of Rotor vs. Magnetic Axis of Stator

The rotor angle, measured by an encoder, needs to be adjusted to the magnetic axis of the rotor. This is because an incremental encoder has an arbitrary orientation relative to the magnetic axis of the rotor, and the rotor has an arbitrary orientation to magnetic axis of the stator.

The direction of counting depends on the encoder, its mounting, and wiring and polarities of encoder signals and motor type. So, the direction of encoder counting is programmable for comfortable definition for a given combination of motor and encoder.



3.5.7.1 Direction of Motion - Magnetic Field vs. Position Sensor

For FOC it is essential, that the direction of revolution of the magnetic field is compatible with the direction of motion of the rotor position reconstructed from encoder signals: For revolution of magnetic field with positive direction, the decoder position needs to turn into the same positive direction. For revolution of magnetic field with negative direction, the decoder position needs to turn into the same negative direction.

With an absolute encoder, once adjusted to the relative orientation of the rotor and to the relative orientation of the stator, one could start the FOC without initialization of the relative orientations.

3.5.7.2 Bang-Bang Initialization of the Encoder

A Bang-Bang initialization is an initialization where the motor is forced with high current into a specific position. For Bang-Bang initialization, the user sets a current into direction D that is strong enough to move the rotor into the desired direction. Other initialization methods ramp up the current smoothly and adjust the current vector to rotor movement detected by the encoder.

3.5.7.3 Encoder Initialization using Hall Sensors

The encoder can be initialized using digital Hall sensor signals. Digital Hall sensor signals give absolute positions within each electrical period with a resolution of sixty degrees. If the Hall sensor signals are used to initialize the encoder position on the first change of a Hall sensor signal, an absolute reference within the electrical period for commutation is given.

3.5.7.4 Minimum Movement Initialization of the Encoder

For minimal movement initialization of the encoder, the user slowly increases a current into direction D and adjusts an offset of the measured angle in a way that the rotor of the motor does not move during initialization while the offset of the measured angle is determined.

3.5.8 Knowledge of Relevant Motor Parameters and Position Sensor (Encoder) Parameters

3.5.8.1 Number of Pole Pairs of a Motor

The number of pole pairs is an essential motor parameter. It defines the ratio between electrical revolutions and mechanical revolutions. For a motor with one pole pair, one mechanical revolution is equivalent to one electrical revolution. For a motor with n_{pp} pole pairs, one mechanical revolution is equivalent to n_{pp} electrical revolutions, with $n = 1, 2, 3, 4, \dots$

Some define the number of poles NP instead of number of pole pairs NPP for a motor, which results in a factor of two that might cause confusion. For the TMC4671, we use NPP number of pole pairs.

3.5.8.2 Number of Encoder Positions per Revolution

For the encoder, the number of positions per revolution (PPR) is an essential parameter. The number of positions per revolution is essential for the FOC.

Some encoder vendors give the number of lines per revolution (LPR) or just named line count (LC) as encoder parameter. Line count and positions per revolution might differ by a factor of four. This is because of the quadrature encoding - A signal and B signal with phase shift - that give four positions per



line, enabling the determination of the direction of revolution. Some encoder vendors associate counts per revolution (CPR) or pulses per revolution associated to PPR acronym.

The TMC4671 uses Positions Per Revolution (PPR) as encoder parameter.

3.5.9 Proportional Integral (PI) Controllers for Closed Loop Current Control

Last but not least, two PI controllers are required for the FOC. The TMC4671 is equipped with two PI controllers - one for control of torque generating current I_Q and one to control current I_D to zero.

3.5.10 Pulse Width Modulation (PWM) and Space Vector Pulse Width Modulation (SVPWM)

The PWM power stage is a must-have for energy efficient motor control. The PWM engine of the TMC4671 just needs a couple of parameters to set PWM frequency f_{PWM} and switching pauses for both high side switches t_{BBM_H} and low side switches t_{BBM_L} . Some control bits are for the programming of power switch polarities for maximum flexibility in the selection in gate drivers for the power MOS-FETs. An additional control bit selects SVPWM on or off. The TMC4671 allows for change of PWM frequency by a single parameter during operation.

With this, the TMC4671 is advanced compared to software solutions where PWM and SVPM configuration of CPU internal peripherals normally needs settings of many parameters.



3.5.11 Orientations, Models of Motors, and Coordinate Transformations

The orientation of magnetic axes (U, V, W for FOC3 resp. X, Y for FOC2) is essential for the FOC together with the relative orientation of the rotor. Here, the rotor is modeled by a bar magnet with one pole pair ($n_{\text{pole_pairs}} = 1$) with magnetic axis in north-south direction.

The actual magnetic axis of the stator - formed by the motor coils - is determined by measurement of the coil currents.

The actual magnetic axis of the rotor is determined by incremental encoder or by Hall sensors. Incremental encoders need an initialization of orientation, where Hall sensors give an absolute orientation, but with low resolution. A combination of Hall sensor and incremental encoder is useful for start-up initialization.

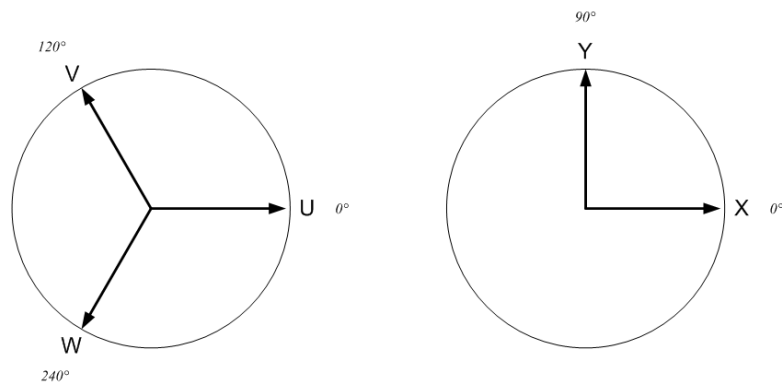

Figure 3: Orientations Uvw (FOC3) and XY (FOC2)

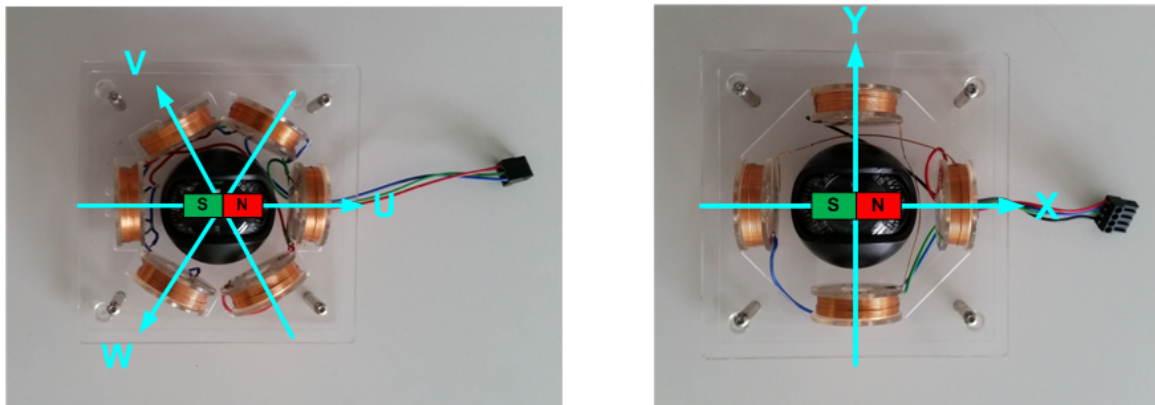

Figure 4: Compass Motor Model w/ 3 Phases Uvw (FOC3) and Compass Motor Model w/ 2 Phases (FOC2)



4 Functional Description

The TMC4671 is a fully integrated controller for field-oriented control (FOC) of either one 3-phase brushless motor (FOC3) or one 2-phase stepper motor (FOC2) or, as well as 1-phase DC motor or voice coil actuator (FOC1). Containing the complete control loop core architecture (position, velocity, torque), the TMC4671 also has the required peripheral interfaces for communication with an application controller, for feedback (digital encoder, analog interpolator encoder, digital Hall with interpolator, analog inputs for current and voltage measurement), and helpful additional IOs. The TMC4671 supports highest control loop speed and PWM frequencies.

The TMC4671 is the building block which takes care of all real-time critical tasks of field-oriented motor control. It decouples the real-time field-oriented motor control and its real-time sub-tasks such as current measurement, real-time sensor signal processing, and real-time PWM signal generation from the user application layer as outlined by figure 5.

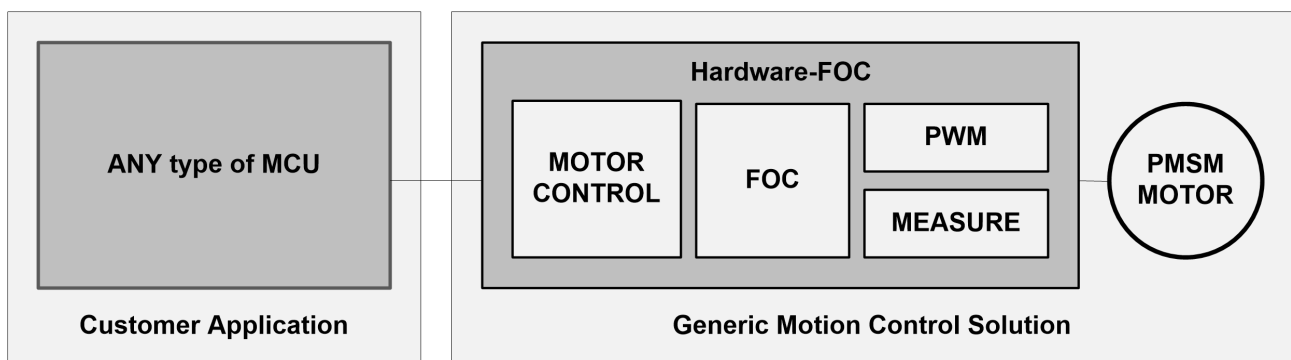

Figure 5: Hardware FOC Application Diagram

4.1 Functional Blocks

The Application interface, register bank, ADC engine, encoder engine, FOC torque PI controller, velocity PI controller, position P controller, and PWM engine make up the TMC4671.

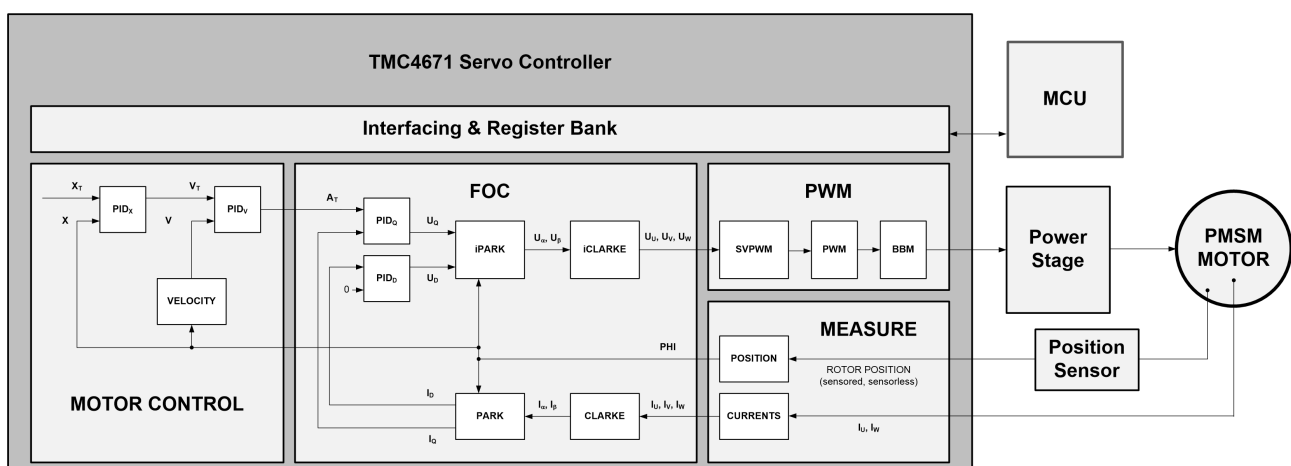

Figure 6: Hardware FOC Block Diagram



The ADC engine interfaces the integrated ADC channels and maps raw ADC values to signed 16 bit (s16) values for the inner FOC current control loop based on programmable offset and scaling factors. The FOC torque PI controller forms the inner base component including required transformations (Clark, Park, inverse Park, inverse Clark). All functional blocks are pure hardware.

4.2 Communication Interfaces

The TMC4671 is equipped with an SPI slave user interface for access to all registers of the TMC4671. The SPI slave user interface is the main application interface.

An additional UART interface is intended for system setup. With that interface, the user can access all registers of the TMC4671 in parallel to the application accessing them via the SPI communication interface - via the user's firmware or via evaluation boards and the TMCL-IDE. The data format of the UART interface is similar to the SPI communication interface - SPI 40 bit datagrams sent to the TMC4671 and SPI 40 bit datagrams received by the MCU vs. five bytes sent via UART and five bytes received via UART. Sending a burst of different real-time data for visualization and analysis via the TMCL-IDE can be triggered using special datagrams. With that, the user can set up an embedded application together with the TMCL-IDE, without having to write a complex set of visualization and analysis functions. The user can focus on its application.

The TMC4671 is also equipped with an additional SPI master interface (TRINAMIC Real-time Monitoring Interface, DBGSPI) for high-speed visualization of real-time data together with the TMCL-IDE.

4.2.1 SPI Slave User Interface

The SPI of the TMC4671 for the user application has an easy command and control structure. The TMC4671 user SPI acts as a slave. The SPI datagram length is 40 bit with a clock rate up to 8 MHz (1 MHz for the TMC4671-ES).

- The MSB (bit#39) is sent first. The LSB (bit#0) is sent last.
- The MSB (bit#39) is the WRITE_notREAD (WRnRD) bit.
- The bits (bit#39 to bit#32) are the address bits (ADDR).
- Bits (bit#31) to (bit#0) are 32 data bits.

The SPI of the TMC4671 immediately responses within the actual SPI datagram on read and write for ease-of-use communication and uses SPI mode 3 with CPOL = 1 and CPHA = 1.

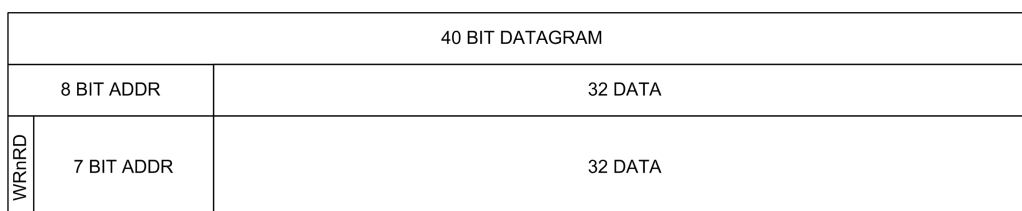

Figure 7: SPI Datagram Structure

A simple SPI datagram example:

```
0x8100000000 // 1st write 0x00000000 into address 0x01 (CHIPINFO_ADDR)
0x0000000000 // 2nd read register 0x00 (CHIPINFO_DATA), returns 0x34363731 <=> ACSII "4671"
```



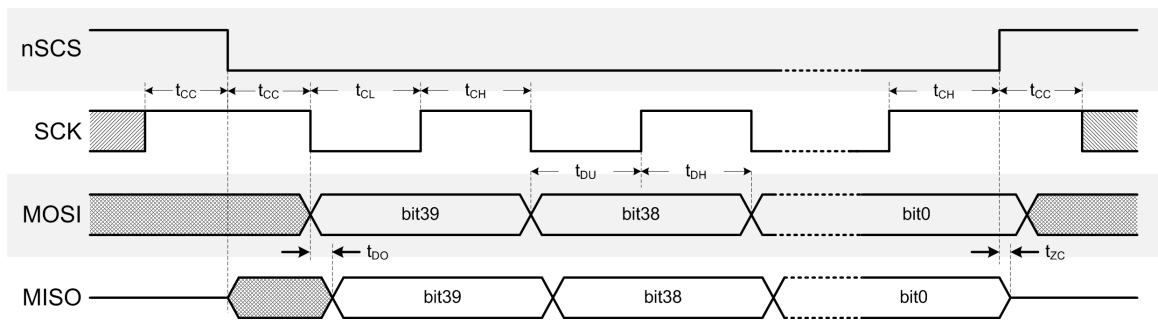

Figure 8: SPI Timing

SPI Interface Timing		Characteristics, fCLK = 25MHz			
Parameter	Symbol	Min	Typ	Max	Unit
SCK valid before or after change of nSCS	t_{CC}	62.5			ns
nSCS high time	t_{CSH}	62.5			ns
nSCS low time	t_{CSL}	62.5			ns
SCK high time	t_{CH}	62.5			ns
SCK low time	t_{CL}	62.5			ns
SCK low time	t_{CL}	62.5			ns
tSCKpause time after read address byte	$t_{SCKpause}$	500			ns
SCK frequency with tSCKpause after write address	$f_{SCKpauseWR}$			8	MHz
SCK frequency for write access without pause	f_{SCKwr}			8	MHz
SCK frequency with tSCKpause after read address	$f_{SCKpauseRD}$			8	MHz
SCK frequency for read access without tSCKpause	f_{SCKrd}			2	MHz
MOSI setup time before rising edge of SCK	t_{DU}	62.5			ns
MOSI hold time after falling edge of SCK	t_{DH}	62.5			ns
MISO data valid time after falling edge of SCK	t_{DO}			10	ns

Table 2: SPI Timing Parameter



Info

SPI write access can be performed up to 8 MHz SPI clock frequency. SPI read access can be performed up to 8 MHz SPI clock frequency if a pause of at least 500 ns is inserted after transfer of the address byte of the SPI datagram. Without a pause of 500 ns after address byte, SPI read access can be performed up to 2 MHz SPI clock frequency.

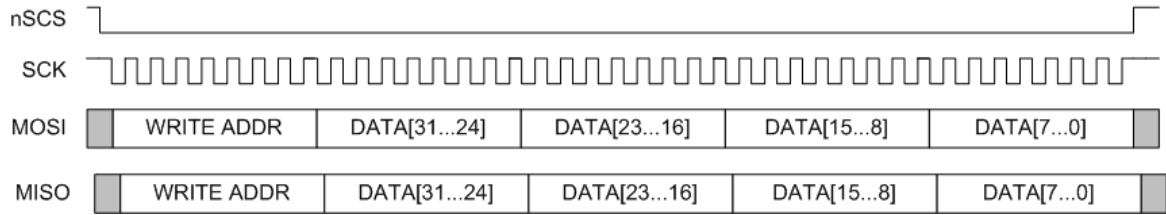

Figure 9: SPI Timing of Write Access without pause with f_{SCK} up to 8MHz

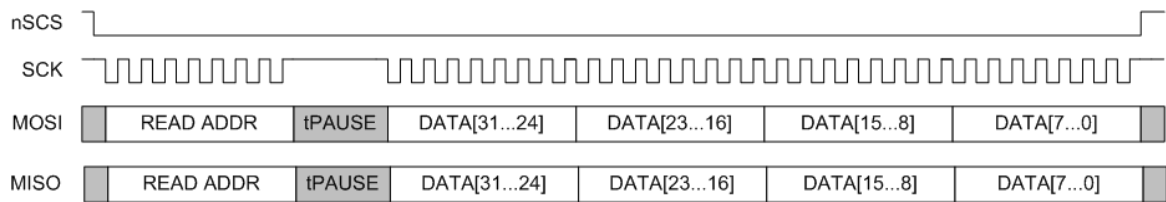

Figure 10: SPI Timing of Read Access with pause (t_{PAUSE}) of 500 ns with f_{SCK} up to 8MHz.



4.2.2 TRINAMIC Real-Time Monitoring Interface (SPI Master)

The TRINAMIC Real-Time Monitoring Interface (RTMI, SPI Master) is an additional fast interface enabling real-time identification of motor and system parameters. The user can check configuration and access registers in the TMC4671 via the TMCL-IDE with its build-in configuration wizards for FOC setup in parallel to the user firmware. TRINAMIC provides a Monitoring Adapter to access the interface, which connects easily to a single 10 pin high density connector (Type: Hirose DF20F-10DP-1V) on the user's PCB or on the evaluation board. If the interface is not needed, pins can be left open or can be used as GPIOs according to the specification. The connector needs to be placed near the TMC4671. Its assignment is pictured in figure 11.

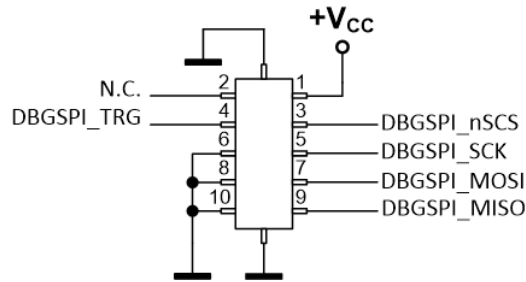

Figure 11: Connector for Real-Time Monitoring Interface (Connector Type: Hirose DF20F-10DP-1V)



4.2.3 UART Interface

The UART interface is a simple three pin (GND, RxD, TxD) 3.3V UART interface with up to 3 Mbit/s transfer speed with one start bit, eight data bits, one stop bit, and no parity bits (1N8). The default speed is 9600 bps. Other supported speeds are 115200 bps, 921600 bps, and 3000000 bps. The speed must be changed manually in register 0x79 UART_BPS.

i Info

The baudrates must be entered as hexadecimal numbers. Table 3 lists the register value and its corresponding baudrate.

Value of register 0x79	selected baudrate
0x00009600	9600 bps
0x00115200	115200 bps
0x00921600	921600 bps
0x03000000	3000000 bps

Table 3: Possible baudrates and corresponding values for register 0x79

With an 3.3V-UART-to-USB adapter cable (e.g. FTDI TTL-232R-RPi), the user can use the full maximum data rate. The UART port enables In-System-Setup-Support by multiple-ported register access.

An UART datagram consists of five bytes - similar to the datagrams of the SPI. In contrast to SPI, the UART interface has a time out feature. So, the five bytes of a UART datagram need to be send within one second. A pause of sending more than one second causes a time out and sets the UART protocol handler back into IDLE state. In other words, waiting for more than one second in sending via UART ensures that the UART protocol handler is in IDLE state.

A simple UART example (similar to the simple SPI example):

```
0x81 0x00 0x00 0x00 0x00 // 1st write 0x00000000 into address 0x01 (CHIPINFO_ADDR)
0x00 0x00 0x00 0x00 0x00 // 2nd read register 0x00 (CHIPINFO_DATA), returns 0x34363731
```

Why UART Interface? It might become necessary during the system setup phase to simply access some internal registers without disturbing the application, without changing the actual user application software, and without adding additional debugging code that might disturb the application software itself. The UART enables this supporting function. In addition, it also enables easy access for monitoring purposes with its very simple and direct five byte protocol. The UART interface is available to write periodically positions into the TMC4671 via an external CPU used as a protocol translator to enable absolute encoders for the TMC4671.



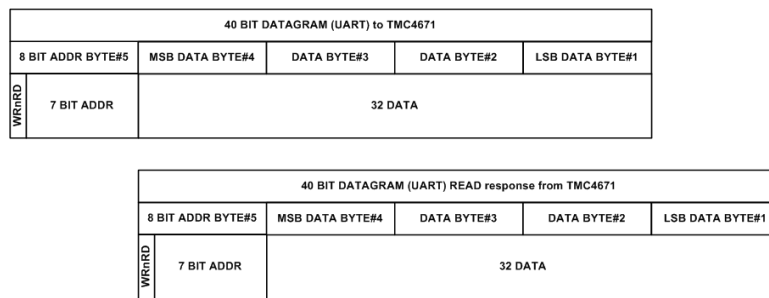

Figure 12: UART Read Datagram (TMC4671 register read via UART)

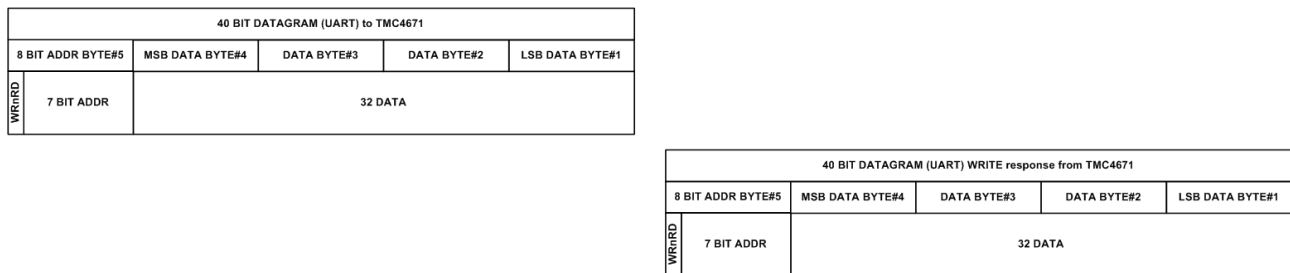

Figure 13: UART Write Datagram (TMC4671 register write via UART)

4.2.4 Step/Direction Interface

The user can manipulate the target position via the step direction interface. It can be enabled by setting the STEP_WIDTH (s32) register to a proper step width. The power-on default value of STEP_WIDTH is 0 that causes position target update with 0 step width that is no stepping. With STEP_WIDTH ≠ 0 each step pulse on STEP input causes incrementing or decrementing of target position depending on polarity of DIR input. For positive STEP_WIDTH, DIR = 0 causes incrementing and the DIR = 1 causes decrementing of the target position. For negative STEP_WIDTH, DIR = 0 causes decrementing and DIR = 1 causes incrementing of the target position. This is because the STEP_WIDTH is represented as a signed number.

4.2.5 Single Pin Interface

The TMC4671 can be operated in Motion Modes in which the main target value is calculated from either a PWM input signal on PIN PWM_I or by analog input to AGPI_A.

Number	Motion Mode	Using PWM_I or AGPI_A
0	Stopped Mode	no
1	Torque Mode	no
2	Velocity Mode	no
3	Position Mode	no
4	PRBS Flux Mode	no
5	PRBS Torque Mode	no
6	PRBS Velocity Mode	no



Number	Motion Mode	Using PWM_I or AGPI_A
7	PRBS Position Mode	no
8	UQ UD Ext Mode	no
9	(reserved)	no
10	AGPI_A Torque Mode	AGPI_A
11	AGPI_A Velocity Mode	AGPI_A
12	AGPI_A Position Mode	AGPI_A
13	PWM_I Torque Mode	PWM_I
14	PWM_I Velocity Mode	PWM_I
15	PWM_I Position Mode	PWM_I

Table 4: Single Pin Interface Motion Modes

Registers SINGLE_PIN_IF_OFFSET and SINGLE_PIN_IF_SCALE can be used to scale the value to desired range. In case of the PWM input, a permanent low input signal or permanent high signal is treated as input error and chosen target value is set to zero.

Register SINGLE_PIN_IF_CFG configures the length of a digital filter for the PWM_I signal. Spikes on the signal can be thereby suppressed. Bit 0 in register SINGLE_PIN_IF_STATUS is set high when PWM_I is constant low, Bit 1 is set high when the PWM_I is constant high. Writing to this register resets these flags. Maximum PWM period of the PWM signal must be 65000 x 40 ns. The calculation of the normalized duty cycle is started on the rising edge of PWM_I. The PWM frequency needs to be constant as big variations (tolerance of 4 us in PWM period) in the PWM frequency are treated as error.

A duty cycle of 50% equals an input value of 32768. With the offset and scaling factors it can be mapped to desired range.

4.2.6 GPIO Interface

The TMC4671 has eight GPIO-pins that are arranged in group A (GPIO 0 to 3) and group B (GPIO 4 to 7). These pins can be configured using bits 0 to 6 of the register GPIO_dsADCI_CONFIG (0x7B). The configurations include RTMI, GPI or GPO as well as clock signals, in and out, for external delta sigma modulators. Groups A and B can individually be configured as in or outputs. Single pins within these groups can not be individually configured. Bits 16 to 19 set the GPO values for group A and bits 20 to 23 set the GPO values for group B. If configured as GPIs bits 24 to 27 display the input on group A whereas bits 28 to 31 display the input on the group B GPIs.

GPIO_dsADCI_CONFIG (bits 6 to 0)	Configured as	group A	group B
xxxxxx0 _b	RTMI	0: Z 1: Z 2: Z 3: /CS	4: SCK 5: MOSI 6: MISO 7: TRG
xx11001 _b	GPIO	GPO	GPO
xx00001 _b	GPIO	GPI	GPI
xx01001 _b	GPIO	GPO	GPI
xx10001 _b	GPIO	GPI	GPO



GPIO_dsADCI_CONFIG (bits 6 to 0)	Configured as	group A	group B
11xx111 _b	Delta Sigma ADC	MCLK_out	MCLK_out
		0: ADCI0	4: ADCAGPI_B
		1: ADCI1	5: AENC_UX
		2: ADCVM	6: AENC_VN
3: ADCAGPI_A	7: AENC_WY		
00xx111 _b	Delta Sigma ADC	MCLK_in	MCLK_in
		0: ADCI0	4: ADCAGPI_B
		1: ADCI1	5: AENC_UX
		2: ADCVM	6: AENC_VN
3: ADCAGPI_A	7: AENC_WY		

Table 5: GPIO Configuration Overview with 'x' as don't care

Info

When the RTMI-option is selected it is not possible to use the GPIOs and the other way around. On default the RTMI-Mode is chosen and the unused GPIOs 0,1 and 2 are configured as inputs on high impedance Z.

4.3 Numerical Representation, Electrical Angle, Mechanical Angle, and Pole Pairs

The TMC4671 uses different numerical representations for different parameters, measured values, and interim results. The terms electrical angle PHI_E, mechanical angle PHI_M, and number of pole pairs (N_POLE_PAIRS) of the motor are important for setup of FOC. This section describes the different numerical representations of parameters and terms.

4.3.1 Numerical Representation

The TMC4671 uses signed and unsigned values of different lengths and fixed point representations for parameters that require a non-integer granularity.

Symbol	Description	Min	Max
u16	unsigned 16 bit value	0	65535
s16	signed 16 bit values, 2'th complement	-32767	32767
u32	unsigned 32 bit value	0	$2^{32} = 4294967296$
s32	signed 32 bit values, 2'th complement	-2147483647	$2^{31} - 1 = 2147483647$
q8.8	signed fix point value with 8 bit integer part and 8 bit fractional part	-32767/256	32767/256
q4.12	signed fix point value with 4 bit integer part and 12 bit fractional part	-32767/4096	32767/4096

Table 6: Numerical Representations



Info

Two's complement of n bit is $-2^{(n-1)} \dots -2^{(n-1)} - 1$. To avoid unwanted overflow, the range is clipped to $-2^{(n-1)} + 1 \dots -2^{(n-1)} - 1$.

Because the zero is interpreted as a positive number for 2th complement representation of integer n bit number, the smallest negative number is $-2^{(n-1)}$ where the largest positive number is $2^{(n-1)} - 1$. Using the smallest negative number $-2^{(n-1)}$ might cause critical underflow or overflow. Internal clipping takes this into account by mapping $-2^{(n-1)}$ to $-2^{(n-1)} + 1$.

Hexadecimal Value	u16	s16	q8.8	q4.12
0x0000 _h	0	0	0.0	0.0
0x0001 _h	1	1	1 / 256	1 / 4096
0x0002 _h	2	2	2 / 256	2 / 4096
0x0080 _h	128	128	0.5	0.03125
0x0100 _h	256	256	1.0	0.0625
0x0200 _h	512	512	2.0	0.125
0x3FFF _h	16383	16383	16383 / 256	16383 / 4096
0x5A81 _h	23169	23169	23169 / 256	23169 / 4096
0x7FFF _h	32767	32767	32767 / 256	32767 / 4096
0x8000 _h	32768	-32768	-32768 / 256	-32768 / 4096
0x8001 _h	32769	-32767	-32767 / 256	-32767 / 4096
0x8002 _h	32770	-32766	-32766 / 256	-32766 / 4096
0xC001 _h	49153	-16383	-16383 / 256	-16383 / 4096
0xFFFE _h	65534	-2	-2 / 256	-2 / 4096
0xFFFF _h	65535	-1	-1 / 256	-1 / 4096

Table 7: Examples of u16, s16, q8.8, q4.12

The q8.8 and q4.12 are used for P and I parameters which are positive numbers. Note that q8.8 and q4.12 are used as signed numbers. This is because these values are multiplied with signed error values resp. error integral values.

4.3.2 N_POLE_PAIRS, PHI_E, PHI_M

The parameter N_POLE_PAIRS defines the factor between electrical angle PHI_E and mechanical angle PHI_M of a motor (pls. refer figure 14).

A motor with one (1) pole pair turns once for each electrical period. A motor with two (2) pole pairs turns once for every two electrical periods. A motor with three (3) pole pairs turns once for every three electrical periods. A motor with four pole (4) pairs turns once for every four electrical periods.

The electrical angle PHI_E is relevant for the commutation of the motor. It is relevant for the torque control of the inner FOC loop.



$$\text{PHI}_E = \text{PHI}_M \cdot \text{N_POLE_PAIRS} \quad (5)$$

The mechanical angle PHI_M is primarily relevant for velocity control and for positioning. This is because one wants to control the motor speed in terms of mechanical turns and not in terms of electrical turns.

$$\text{PHI}_M = \text{PHI}_E / \text{N_POLE_PAIRS} \quad (6)$$

Different encoders give different kinds of position angles. Digital Hall sensors normally give the electrical position PHI_E that can be used for commutation. Analog encoders give - depending on their resolution - angles that have to be scaled first to mechanical angles PHI_M and to electrical angles PHI_E for commutation.

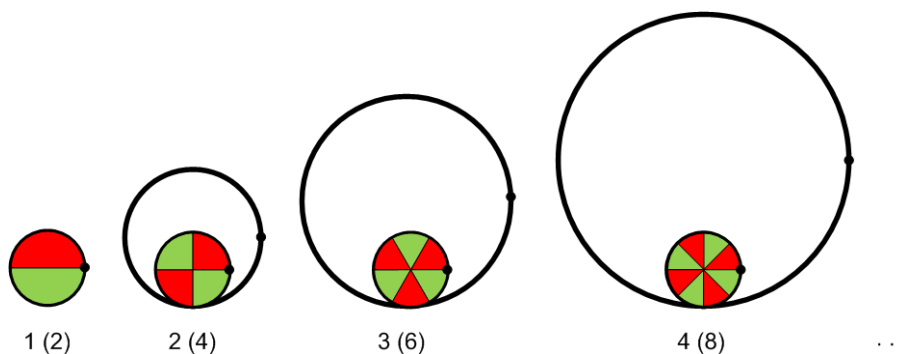

Figure 14: N_POLE_PAIRS - Number of Pole Pairs (Number of Poles)

4.3.3 Numerical Representation of Angles PHI

Electrical angles and mechanical angles are represented as 16 bit integer values. One full revolution of 360 deg is equivalent to $2^{16} = 65536$ steps. Any position coming from a sensor is mapped to this integer range. Adding an offset of PHI_OFFSET causes a rotation of an angle $\text{PHI_OFFSET} / 2^{16}$. Subtraction of an offset causes a rotation of an angle PHI_OFFSET in opposite direction.



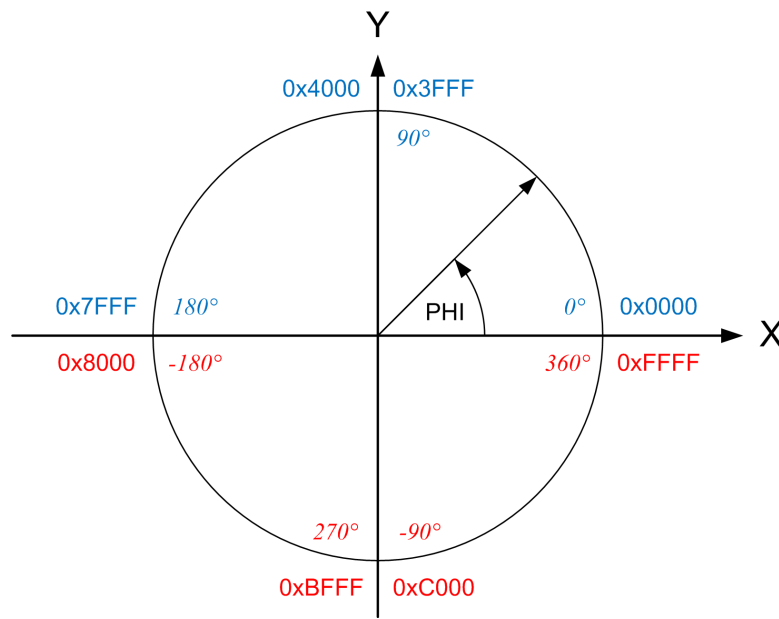

Figure 15: Integer Representation of Angles as 16 Bit signed (s16) resp. 16 Bit unsigned (u16)

Hexadecimal Value	u16	s16	PHI[°] _{u16}	PHI[°] _{s16}
0x0000 _h	0	0	0.0	0.0
0x1555 _h	5461	5461	30.0	30.0
0x2AAA _h	10922	10922	60.0	60.0
0x4000 _h	16384	16384	90.0	90.0
0x5555 _h	21845	21845	120.0	120.0
0x6AAA _h	27306	27768	150.0	150.0
0x8000 _h	32768	-32768	180.0	-180.0
0x9555 _h	38229	-27307	210.0	-150.0
0xAAAA _h	43690	-21846	240.0	-120.0
0xC000 _h	49152	-16384	270.0	-90.0
0xD555 _h	54613	-10923	300.0	-60.0
0xEAAA _h	60074	-5462	330.0	-30.0

Table 8: Examples of u16, s16, q8.8

The option of adding an offset is for adjustment of angle shift between the motor and stator and the rotor and encoder. Finally, the relative orientations between the motor and stator and the rotor and encoder can be adjusted by just one offset. Alternatively, one can set the counter position of an incremental encoder to zero on initial position. For absolute encoders, one needs to use the offset to set an initial position.



4.4 ADC Engine

The ADC engine controls the sampling, selection, scaling and offset correction of different available ADC channels. Two ADC channels are for phase current measurement, three ADC channels are for analog Hall signals or for analog sin-cos-encoder, one ADC channel is for optional measurement of the motor supply voltage, two additional ADC channels are general purpose where one general purpose analog input can be used as analog target value by the single pin interface.

4.4.1 ADC current sensing channels ADC_I1 and ADC_I0

The ADC channels (ADC_I0_POS, ADC_I0_NEG, ADC_I1_POS, ADC_I1_NEG) are for current sensing in differential input configuration. In differential configuration, the ADC_I0_POS and ADC_I0_NEG are the inputs for the sense amplifier output signals where ADC_I1_POS and ADC_I1_NEG are for the zero current sensing reference of the sense amplifiers. In single ended configuration, the ADC_I0_POS and ADC_I0_NEG are the inputs for the sense amplifier output signals where ADC_I1_POS and ADC_I1_NEG are internally connected to ground. The third current channel ADC_I2 as required for three phase FOC is calculated using Kirchhoff's law $ADC_I2 = -(ADC_I1 + ADC_I0)$.

i Info

ADC_I0_POS, ADC_I0_NEG, ADC_I1_POS, ADC_I1_NEG are low voltage analog inputs and must not directly connected to in-line sense resistors. The TMC4671 requires external differential motor supply common mode range current sensing amplifiers for in-line current sensing.

4.4.2 ADC for analog Hall signals or analog sin-cos-encoders AENC_UX, AENC_VN, AENC_WY

For analog Hall and for analog encoder, the ADC engine has three differential input channels (AENC_UX_POS, AENC_UX_NEG), (AENC_VN_POS, AENC_VN_NEG), and (AENC_WY_POS, AENC_WY_NEG). The analog encoder ADC inputs can be configured single ended (AENC_UX_POS, AENC_VN_POS, AENC_WY_POS) with negative inputs (AENC_UX_NEG, AENC_VN_NEG, AENC_WY_NEG) internally connected to ground.

The three channels AENC_UX, AENC_VN, AENC_WY are for three phase analog sine (with +/-120° phase shift) wave Hall signals. The Signals AENC_UX and AENC_WY are for two phase analog sine wave and cosine wave Hall signals. The Signals AENC_UX and AENC_WY are for analog sin-cos-encoder. The AENC_VN is for an optional zero pulse channel of sin-cos-encoders. The AENC_VN is available for read out by the application software but it is not hardware handled by the TMC4671 for position zeroing.

For long analog signal lines, it might be necessary to use external differential receivers with twisted pair line termination resistors to drive the single ended analog encoder inputs of the TMC4671.

4.4.3 ADC supply voltage measurement ADC_VM

The ADC channel for measurement of supply voltage (ADC_VM) and is associated with the brake chopper. The ADC_VM is available as raw value only without digital scaling. This is because it is not directly processed by the FOC engine.

i Info

ADC_VM must be scaled down electrically by voltage divider to the allowed voltage range, and might require additional supply voltage spike protection.



4.4.4 ADC_VM for Brake Chopper

The ADC_VM is available as input for optional brake chopper as raw value u16. The brake chopper thresholds have to be set as absolute u16 values to activate and deactivate the brake chopper output depending on the ADC_VM value.

4.4.5 ADC_EXT register option

The user can write ADC values into the ADC_EXT registers of the register bank from external sources or for evaluation purposes. These values can be selected as raw current ADC values by selection. ADC_EXT registers are primarily intended for test purposes as optional inputs for external current measurement sources.

4.4.6 ADC general purpose analog inputs AGPI_A and AGPI_B

Two general purpose ADC channels are single-ended analog inputs (AGPI_A, AGPI_B). The general purpose analog ADC inputs AGPI_A and AGPI_B are available as raw values only without digital scaling. This is because these values are not directly processed by the FOC engine. These general purpose analog inputs (AGPI) are intended to monitor analog voltage signals representing MOSFET temperature or motor temperature. They are two additional ADC channels for the user. Optional, the AGPI_A is available as analog target value signal.

4.4.7 ADC RAW values

The sampled raw ADC values are available for read out by the user. This is important during the system setup phase to determine offset and scaling factors.

4.4.8 ADC_SCALE and ADC_OFFSET

The FOC engine expects offset corrected ADC current values scaled to the used 16 bit (s16) fixed point representation. The integrated scaler and offset compensator maps raw ADC samples of current measurement channels to 16 bit two's complement values (s16). While the offset is compensated by subtraction, the offset is represented as an unsigned value. The scaling value is signed to compensate wrong measurement direction. The s16 scaled ADC values are available for read out from the register (ADC_I1, ADC_I0) resp. (AENC_UX, AENC_VN, AENC_WY) by the user.

i Info

Wrong scaling factors (ADC_SCALE) or wrong offsets (ADC_OFFSET) might cause damages when the FOC is active. Integrated hardware limiters allow protection - especially in the setup phase when using careful limits.

4.4.9 ADC Gain Factors for Real World Values

Each ADC channel of the TMC4671 has an individual gain factor determined by its associated chain of gain factors and by digital scaling factors if available for an ADC channel. ADC register values are either 16 bit unsigned values (u16) or 16 bit signed values (s16). With gain factors one can calculate ADC values as real world values if required.



Gain factors $I_{gainADC}$ for ADC current values are typical in units [A/LSB] or [mA/LSB]. Gain factors $U_{gainADC}$ for ADC voltage values are typical in units [V/LSB] or [mV/LSB].

$$ADC_{measuredCurrent}[A] = I_{gainADC}[A/LSB] * ADC_CURRENT_S16 \quad (7)$$

$$ADC_{measuredVoltage}[V] = U_{gainADC}[V/LSB] * ADC_VOLTAGE_S16 \quad (8)$$

$$ADC_{measuredVoltage}[V] = U_{gainADC}[V/LSB] * ADC_VOLTAGE_U16 \quad (9)$$

4.4.10 Internal Delta Sigma ADCs

The TMC4671 is equipped with internal delta sigma ADCs for current measurement, supply voltage measurement, analog GPIs and analog encoder signal measurement. Delta sigma ADCs, as integrated within the TMC4671, together with programmable digital filters are flexible in parameterizing resolution vs. speed. The advantage of delta sigma ADCs is that the user can adjust measurement from lower speed with higher resolution to higher speed with lower resolution. This fits with motor control application. Higher resolution is required for low speed signals, while lower resolution satisfies the needs for high speed signals.

Due to high oversampling, the analog input front-end is easier to implement than for successive approximation register ADCs as anti aliasing filters can be chosen to a much higher cutoff frequency. The ADC Engine processes all ADC channels in parallel hardware - avoiding phase shifts between the channels compared to ADC channels integrated in MCUs.

4.4.11 Internal Delta Sigma ADC Input Stage Configuration

ADC channels can be configured either as differential ended analog inputs (ADC_I0, ADC_I1, AENC_UX, AENC_VN, AENC_WY) or as single ended analog inputs (ADC_VM, AGPI_A, AGPI_B). Additionally, the ADC all channels can be set to fixed voltages (0V, VREF/4, VREF/2, 3*VREF/4) for calibrations purposes.

STAGE_CFG(n+2:n)	CONFIGURATION	DESCRIPTION	COMMENT
0	INP vs. INN	differential mode	default configuration
1	GND vs. INN	single ended negative INN vs. GND	(for test purposes only)
2	VDD/4	25% ADC reference voltage	calibration aid
3	3*VDD/4	75% ADC reference voltage	calibration aid
4	INP vs. GND	single ended mode INP vs. GND	(half voltage range, offset)
5	VDD/2	50% ADC reference voltage	calibration aid
6	VDD/4	25% ADC reference voltage	(redundant configuration)
7	3*VDD/4	75% ADC reference voltage	(redundant configuration)

Table 9: Delta Sigma ($\Delta\Sigma$) ADC Input Stage Configurations

The three bit vector $ADC_STAGES_CFG(n+2:n)$ is part of the $DS_ANALOG_INPUT_STAGE_CFG(31:0)$ with $n = 0, 4, 8, 12, 16, 20, 24, 28$ for the eighth delta sigma ADC channels. $DS_ANALOG_INPUT_STAGE_CFG$



configures the associated delta sigma ADC input stages according to table 17. For association of the bit position (bit n+2 to bit n) refer register bank section 7.2.

STAGE_CFG(n+2:n)	ADC channel	function
STAGE_CFG(2:0)	ADC_I0	sense voltage of current I0
STAGE_CFG(6:4)	ADC_I1	sense voltage of current I1
STAGE_CFG(9:8)	ADC_VM	down divided supply voltage
STAGE_CFG(10)	'1'	fixed for ADC_VM (STAGE_CFG=4,5,6,7)
STAGE_CFG(13:12)	ADC_AGPI_A	general purpose analog input A
STAGE_CFG(14)	'1'	fixed for ADC_AGPI_A (STAGE_CFG=4,5,6,7)
STAGE_CFG(17:16)	ADC_AGPI_B	general purpose analog input B
STAGE_CFG(18)	'1'	fixed for ADC_AGPI_B (STAGE_CFG=4,5,6,7)
STAGE_CFG(22:20)	ADC_AENC_UX	analog Hall UX / analog encoder COS
STAGE_CFG(26:24)	ADC_AENC_VN	analog Hall V / analog encoder N
STAGE_CFG(30:28)	ADC_AENC_WY	analog Hall WY / analog encoder SIN

Table 10: Delta Sigma ($\Delta\Sigma$) ADC Input Stage Configurations

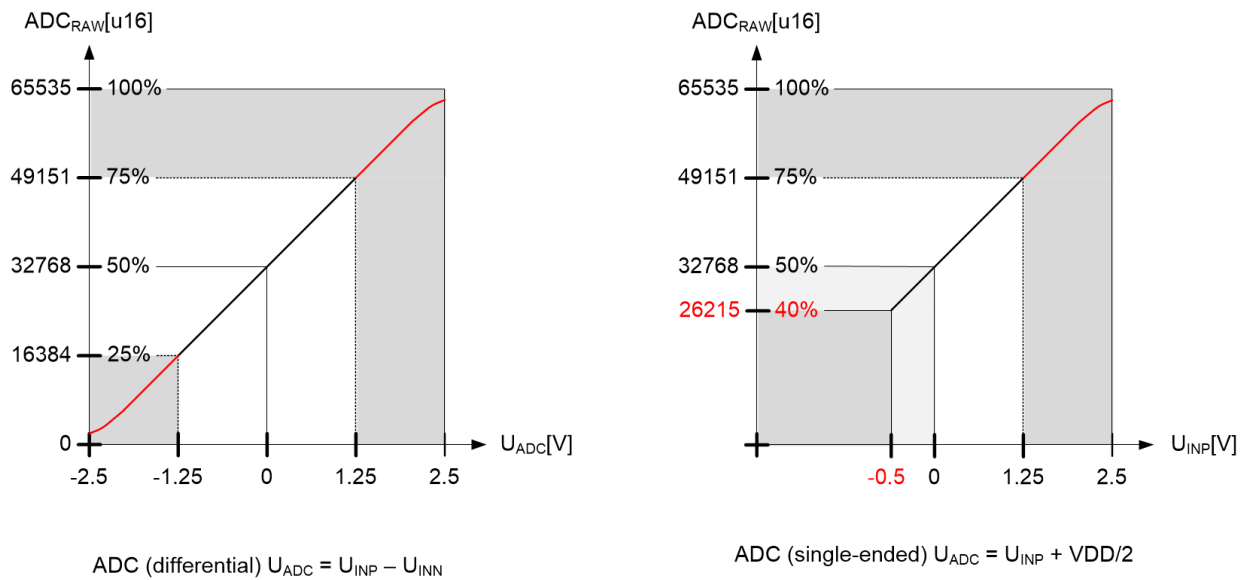

Figure 16: Input Voltage Ranges of internal Delta Sigma ADC Channels



Figure 16 illustrates typical relation between input voltage and corresponding raw ADC output. For differential operation the input range between 25% and 75% corresponds to voltage values between 1.25V to 3.75V. This is the recommended operation area of the ADC. Below 25% and above 75% the ADC shows significant non-linearity due to the Delta Sigma measurement principle. In single ended operation the recommended input range starts at 0V and ends at 1.25V. Measurement below GND might be distorted and is not recommended.

i Info

Due to manufacturing tolerances calibration of offset and amplitude is always recommended. Please also consider stability of the reference voltage.

4.4.12 External Delta Sigma ADCs

The delta sigma front-end of the ADC engine supports external delta sigma modulators to enable isolated delta sigma modulators for the TMC4671. Additionally, the delta sigma front-end supports low-cost comparators together with two resistors and one capacitor (R-C-R-CMP) forming first order delta sigma modulators, as generic analog front-end for pure digital variants of the TMC4671 core.

4.4.13 ADC Group A and ADC Group B

ADC channels of the TMC4671 are grouped into two groups, to enable different sample rates for two groups of analog signals if needed. Running both ADC groups with same sampling frequency is recommended for almost all applications. It might be necessary to run its ADC channels of analog encoder with a much higher frequency than the ADC channels for current measurement in case of using a high resolution analog encoder.

4.4.14 Delta Sigma Configuration and Timing Configuration

The delta sigma configuration is programmed via MCFG register that selects the mode (internal/external delta sigma modulator with programmable MCLK; delta sigma modulator clock mode (MCLK output, MCLK input, MCLK used as MDAC output with external R-C-R-CMP configuration); delta sigma modulator clock and its polarity; and the polarity of the delta sigma modulator data signal MDAT).

i Info

The power-on delta sigma configuration should fit with most applications when using the integrated delta sigma ADCs of the TMC4671. Primarily, the default delta sigma configuration needs to be adapted when using external delta sigma modulators or to select differential ADC input configurations, or in case of enhanced sampling requirement for high resolution analog encoders.



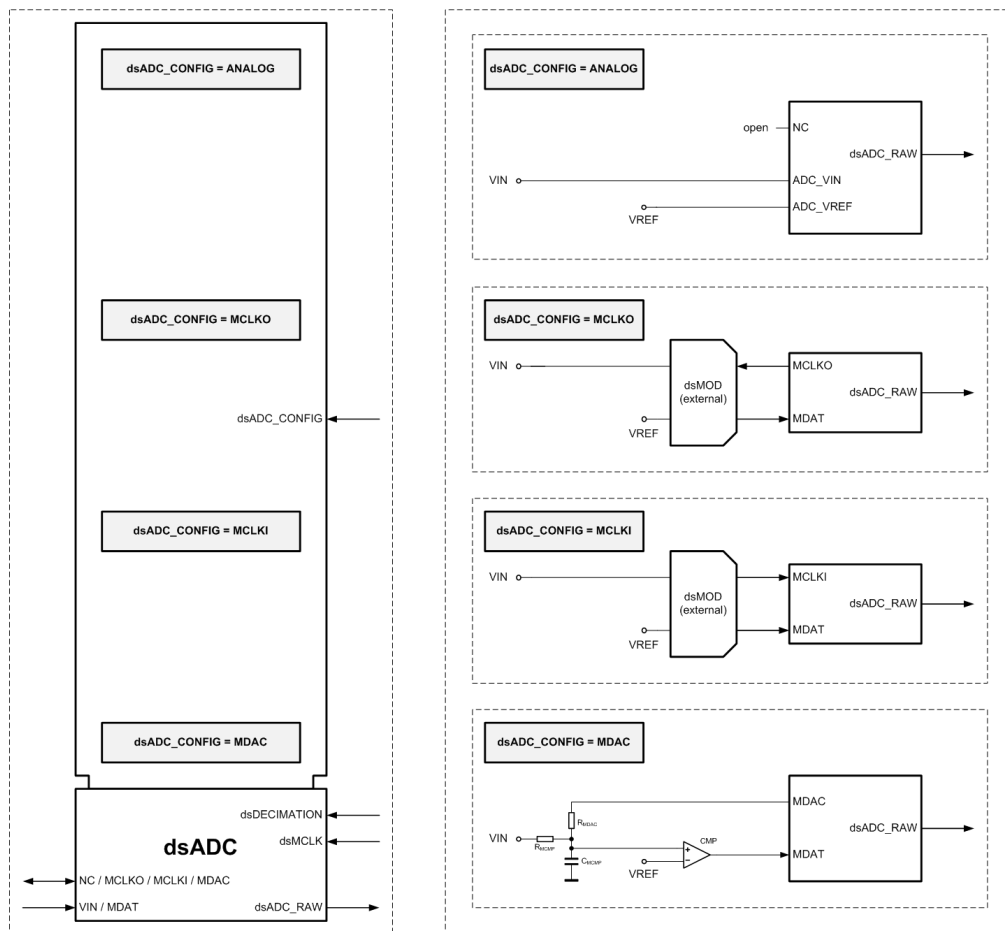

Figure 17: Delta Sigma ADC Configurations dsADC_CONFIG (internal: ANALOG vs. external: MCLKO, MCLKI, MDAC)

dsADC_CONFIG	Description	NC_MCLKO_MCLKI_MDAC	VIN_MDAT
ANALOG	integrated internal ADC mode, VIN_MDAT is analog input VIN	MCLK not connected (NC)	VIN (analog)
MCLKO	external dsModulator (e.g. AD7403) with MCLK input driven by MCLKO	MCLK output	MDAT input
MCLKI	external dsModulator (e.g. AD7400) with MCLK output that drives MCLKI	MCLK input	MDAT input
MDAC	external dsModulator (e.g. LM339) realized by external comparator CMP with two R and one C	MDAC output (= MCLK out)	MDAT input for CMP

Table 11: Delta Sigma ADC Configurations (figure 17), selected with dsADC_MCFG_A and dsADC_MCFG_B.



register	function
dsADC_MCFG_B	delta sigma modulator configuration MCFG (ANALOG, MCLKI, MCLKO, MDAC), group B
dsADC_MCFG_A	delta sigma modulator configuration MCFG (ANALOG, MCLKI, MCLKO, MDAC), group A
dsADC_MCLK_B	delta sigma modulator clock MCLK, group B
dsADC_MCLK_A	delta sigma modulator clock MCLK, group A
dsADC_MDEC_B	delta sigma decimation parameter MDEC, group B
dsADC_MDEC_A	delta sigma decimation parameter MDEC, group A

Table 12: Registers for Delta Sigma Configuration

4.4.14.1 Timing Configuration MCLK

When the programmable MCLK is selected, the MCLK_A and MCLK_B parameter registers define the programmable clock frequency fMCLK of the delta sigma modulator clock signal MCLK for delta sigma modulator group A and group B. For a given target delta sigma modulator frequency fMCLK, together with the internal clock frequency fCLK = 100MHz, the MCLK frequency parameter is calculated by

$$\text{MCLK} = 2^{31} \cdot \text{fMCLK}[Hz] / \text{fCLK}[Hz] \quad (10)$$

Due to the 32 bit's length of the MCLK frequency parameter, the resulting frequency fMCLK might differ from the desired frequency fMCLK. The back calculation of the resulting frequency fMCLK for a calculated MCLK parameter with 32 bit length is defined by

$$\text{fMCLK}[Hz] = \text{fCLK}[Hz] \cdot \text{MCLK} / 2^{31} \quad (11)$$

The precise programming of the MCLK frequency is primarily intended for external delta sigma modulators to meet given EMI requirements. With that, the user can programm frequencies fMCLK with a resolution better than 0.1 Hz. This advantage concerning EMI might cause trouble when using external delta sigma modulators if they are sensitive to slight frequency alternating. This is not an issue when using external first-order delta sigma modulators based on R-C-R-CMP (e.g. LM339). But for external second-order delta sigma modulators, it is recommended to configure the MCLK parameter for frequencies fMCLK with kHz quantization (e.g. 10,001,000 Hz instead of 10,000,001 Hz).

fMCLK_target	MCLK	fMCLK_resulting	comment
25 MHz	0x20000000	25 MHz	w/o fMCLK frequency jitter, recommended
20 MHz	0x19000000	20 MHz -468750 Hz	recommended for ext. $\Delta\Sigma$ modulator
20 MHz	0x19999999	20 MHz -0.03 Hz	might be critical for ext. $\Delta\Sigma$ modulator
12.5 MHz	0x10000000	12.5 MHz	w/o fMCLK frequency jitter, recommended
10 MHz	0x0CCCCCCC	10 MHz -0.04 Hz	might be critical for ext. $\Delta\Sigma$ modulator
10 MHz	0x0CC00000	10 MHz -39062.5 Hz	recommended for ext. $\Delta\Sigma$ modulator

Table 13: Delta Sigma MCLK Configurations



4.4.14.2 Decimation Parameter MDEC

The high oversampled single bit delta sigma data stream (MDAT) is digitally filtered by Sinc3 filters. To get raw ADC data, the actual digitally filtered values need to be sampled periodically with a lower rate called decimation ratio. The decimation is controlled by parameter MDEC_A for ADC group A and MDEC_B for ADC group B. A new ADC_RAW value is available after MDEC delta sigma pulses of MCLK. As such, the parameters MCLK and MDEC together define the sampling rate of the 16 bit ADC_RAW values.

The delta sigma modulator with Sinc3 filter works with best noise reduction performance when the length of the step response time t_{SINC3} of the Sinc3 filter is equal to the length of the PWM period $t_{PWM} = (PWM_MAXCNT+1) / f_{PWMCLK} = ((PWM_MAXCNT+1) * 10 \text{ ns})$ of the period. The length of the step function response of a Sinc3 filter is

$$t_{SINC3} = (3 \cdot (MDEC - 1) + 1) \cdot t_{MCLK} \quad (12)$$

$$MDEC_{\text{recommended}} = \frac{t_{PWM}}{3 \cdot t_{MCLK}} - 2 \quad (13)$$

fMCLK	tMCLK	MDEC25 (25 kHz, 40 μ s)	MDEC50 (50 kHz, 20 μ s)	MDEC100 (100 kHz, 10 μ s)
50 MHz	20 ns	665	331	165
25 MHz	40 ns	331	165	81
20 MHz	50 ns	265	131	65
12.5 MHz	80 ns	165	81	40
10 MHz	100 ns	131	65	31

Table 14: Optimal Decimation Parameter MDEC (according to equation (13) for different PWM frequencies f_{PWM} (MDEC25 for $f_{PWM}=25\text{kHz}$ w/ $PWM_MAXCNT=3999$, MDEC50 for $f_{PWM}=50\text{kHz}$ w/ $PWM_MAXCNT=1999$, MDEC100 for $f_{PWM}=100\text{kHz}$ w/ $PWM_MAXCNT=999$).

i Info

MDEC parameter can be changed during operation. This enables adaptive adjustment of performance with respect to resolution versus speed on demand.

For most applications, the power-on decimation setting of MDEC should be sufficient.



4.4.15 Internal Delta Sigma Modulators - Mapping of V_RAW to ADC_RAW

Generally, delta sigma modulators work best for a typical input voltage range of 25% V_MAX ... 75% V_MAX (unsigned 0% ... 100%) resp. -75% V_MAX ... +75% V_MAX (signed -100% ... +100%). For the integrated delta sigma modulators, this input voltage operation range is recommended with V_MAX = 5V where V_MAX = 3.3V is possible. The table 15 defines the recommended voltage ranges for both 5V and 3.3V analog supply voltages.

V_SUPPLY[V]	(V_MIN[V])	V_MIN25%[V]	V_MAX50%[V]	V_MAX75%[V]	(V_MAX[V])
(3.3)	(0.0)	(0.825)	(1.65)	(2.75)	(3.3)
5.0	(0.0)	1.250	2.50	3.75	(5.0)

Table 15: Recommended input voltage range from V_MIN25%[V] to V_MAX75%[V] for internal Delta Sigma Modulators; V_SUPPLY[V] = 5V is recommended for the analog part of the TMC4671.

$$V_{\text{RAW}} = \begin{cases} V_{\text{MAX}} & \text{for } V_{\text{IN}} > V_{\text{MAX}} \\ (V_{\text{IN}} - V_{\text{REF}}) & \text{for } V_{\text{MIN}} < (V_{\text{IN}} - V_{\text{REF}}) < V_{\text{MAX}} \\ V_{\text{MIN}} & \text{for } V_{\text{IN}} < V_{\text{MIN}} \end{cases} \quad (14)$$

The resulting raw ADC value is

$$\text{ADC_RAW} = (2^{16} - 1) \cdot \frac{V_{\text{RAW}}}{V_{\text{MAX}}} \quad \text{for } V_{\text{MIN}25\%[V]} < V_{\text{RAW}} < V_{\text{MAX}75\%[V]}. \quad (15)$$

The idealized expression (equation 14) is valid for recommended voltage ranges (table 15) neglecting deviations in linearities. These deviations primarily depend on different impedance on the analog signal path, but also on digital parameterization. Finally, the deviation is quantified in terms of resulting ADC resolution. So, the Delta Sigma ADC engine maps the analog input voltages $V_{\text{RAW}} = V_{\text{IN}} - V_{\text{REF}}$ of voltage range $V_{\text{MIN}} < V_{\text{RAW}} < V_{\text{MAX}}$ to ADC_RAW values of range $\{0 \dots (2^{16}) - 1\} \Leftrightarrow \{0 \dots 65535\} \Leftrightarrow \{0x0000 \dots 0xFFFF\}$.

Vmin[V]	Vref[V]	Vmax[V]	VIN[V]	DUTY[%]	ADC_RAW
0.0	2.5	5.0	(0.0)	(0%)	(0x0000)
0.0	2.5	5.0	1.0	25%	0x4000
0.0	2.5	5.0	2.5	50%	0x7fff
0.0	2.5	5.0	3.75	75%	0xC000
0.0	2.5	5.0	(5.0)	(100%)	(0xffff)

Table 16: Delta Sigma input voltage mapping of internal Delta Sigma Modulators

i Info

For calibrating purposes, the input voltage of the delta sigma ADC inputs can be programmed to fixed voltages (25%, 50%, 75% of analog supply voltage) via the associated configuration register DS_ANALOG_INPUT_STAGE_CFG.



4.4.16 External Delta Sigma Modulator Interface

The TMC4671 is equipped with integrated digital filters for extraction of ADC raw values from delta sigma data stream for both internal and external delta sigma modulators. The interface for external delta sigma modulators is intended for external isolated sigma delta modulators, such as AD7401 (with MCLK input driven by TMC4671), or AD7402 (with MCLK output to drive TMC4671). In addition, the external delta sigma interface supports the use of simple comparator with a R-C-R network as external low cost delta sigma modulators (R-C-R-CMP, e.g. LM339).

i Info

When selecting the external delta sigma ADC Interface, the high-performance Debug SPI Interface (RTMI) is not available in parallel due to pin sharing. The UART is always available, but with less performance than the RTMI.

Each external delta sigma modulator channel (dsMOD) has two signals (pls. refer figure 17), one dedicated input, and one programmable input/output. The configuration of the external delta sigma modulator interface is defined by programming associated registers. When selecting external delta sigma ADC, the associated analog ADC inputs are configured as digital inputs for the delta sigma signal data stream MDAT.

4.4.16.1 External Delta Sigma Modulator Interface - MDAC Configuration

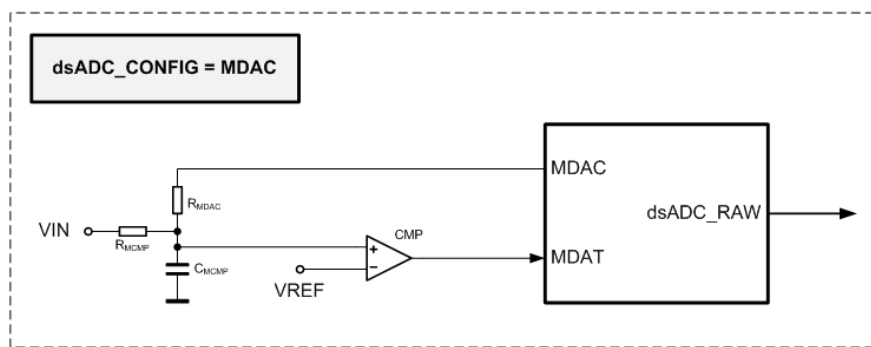

Figure 18: $\Delta\Sigma$ ADC Configuration - MDAC (Comparator-R-C-R as $\Delta\Sigma$ -Modulator)

In the MDAC delta sigma modulator, the delay of the comparator CMP determines the MCLK of the comparator modulator. A capacitor C_{MCMP} within a range of 100 pF ... 1nF fits in most cases. The time constant τ_{RC} should be in a range of 0.1 t_{CMP} ... t_{CMP} of the comparator. The resistors should be in the range of 1K to 10K. The f_{MAXtyp} depends also on the choice of the decimation ratio.

CMP	t_{CMPtyp} [ns]	R_{MCMP} [k Ω]	R_{MDAC} [k Ω]	C_{MCMP} [pF]	$f_{MCLKmaxTYP}$
LM339	1000	1	1	100	1 MHz
LM339	1000	10	10	100	100 kHz
LM339	1000	100	100	100	10 kHz

Table 17: Delta Sigma R-C-R-CMP Configurations (pls. refer 17)



For external Delta Sigma R-C-R-CMP modulators, one gets the Delta Sigma input voltage mapping according to table 18. The support of low-cost external comparators used as first order delta sigmal modulators is intended as an generic analog interface option for compatibility of the TMC4671 core in case it would be embedded within a pure digital technology environment.

Vmin[V]	Vref[V]	Vmax[V]	VIN[V]	DUTY[%]	ADC_RAW
0.0	1.65	3.3	0.0	0%	0x0000
0.0	1.65	3.3	0.825	25%	0x4000
0.0	1.65	3.3	1.65	50%	0x7fff
0.0	1.65	3.3	2.475	75%	0xC000
0.0	1.65	3.3	3.3	100%	0xffff
Vmin[V]	Vref[V]	Vmax[V]	VIN[V]	DUTY[%]	ADC_RAW
0.0	2.5	5.0	0.0	0%	0x0000
0.0	2.5	5.0	1.0	25%	0x4000
0.0	2.5	5.0	2.5	50%	0x7fff
0.0	2.5	5.0	3.75	75%	0xC000
0.0	2.5	5.0	5.0	100%	0xffff

Table 18: Delta Sigma input voltage mapping of external comparator (CMP)



4.5 Analog Signal Conditioning

The range of measured coil currents, resp. the measured voltages of sense resistors, needs to be mapped to the valid input voltage range of the delta sigma ADC inputs. This analog preprocessing is the task of the analog signal conditioning.

4.5.0.1 Chain of Gains for ADC Raw Values

An ADC raw value is a result of a chain of gains that determine it. A coil current I_{SENSE} flowing through a sense resistor causes a voltage difference according to Ohm's law. Finally, a current is mapped to an ADC raw value

$$ADC_RAW = (I_{SENSE} \cdot ADC_GAIN) + ADC_OFFSET. \quad (16)$$

The ADC_GAIN is a result of a chain of gains with individual signs. The sign of the ADC_GAIN is positive or negative, depending on the association of connections between sense amplifier inputs and the sense resistor terminals. The ADC_OFFSET is the result of electrical offsets of the phase current measurement signal path. For the TMC4671, the maximum ADC_RAW value is $ADC_RAW_MAX = (2^{16} - 1)$ and the minimum ADC raw value is $ADC_RAW_MIN = 0$.

$$ADC_GAIN = \left(I_{SENSE_MAX} \cdot R_{SENSE} \right) \cdot SENSE_AMPLIFIER_GAIN \cdot \left(ADC_RAW_MAX / ADC_U_MAX \right) \quad (17)$$

Rsense [$m\Omega$]	Isense [A]	Usense [mV]	GAIN[V/V]	ADC_GAIN[A/V]	Sense Amplifier
5	10	50	20	10	AD8418
10	5	50	20	5	AD8418

Table 19: Example Parameters for ADC_GAIN

For the FOC, the ADC_RAW is scaled by the ADC scaler of the TMC4671 together with subtraction of offset to compensate it. Internally, the TMC4671 FOC engine calculates with s16 values. So, the ADC scaling needs to be chosen so that the measured currents fit into the s16 range. With the ADC scaler, the user can choose a scaling with physical units like [mA]. A scaling to [mA] covers a current range of $-32A \dots +32A$ with [mA] resolution. For higher currents, the user can choose unusual units like centi Ampere [cA] covering $-327A \dots +327A$ or deci Ampere $-3276A \dots +3276A$.

ADC scaler and offset compensators are for mapping raw ADC values to s16 scaled and offset cleaned current measurement values that are adequate for the FOC.

4.5.1 FOC3 - Stator Coil Currents I_U, I_V, I_W and associated Voltages U_U, U_V, U_W

The correct association between stator terminal voltages U_U, U_V, U_W and stator coil currents I_U, I_V, I_W is essential for the FOC.

For three-phase motors with three terminals U, V, W, the voltage U_U is in phase with the current I_U , U_V is in phase with I_V , and U_W is in phase with I_W according to equations (18) and (19) for FOC3.



$$U_{UVW_FOC3}(U_D, PHI_E) = \begin{cases} U_U(\phi_e) = U_D \cdot \sin(\phi_e) \\ U_V(\phi_e) = U_D \cdot \sin(\phi_e + 120^\circ) \\ U_W(\phi_e) = U_D \cdot \sin(\phi_e - 120^\circ) \end{cases} \quad (18)$$

$$I_{UVW_FOC3}(I_D, PHI_E) = \begin{cases} I_U(\phi_e) = I_D \cdot \sin(\phi_e) \\ I_V(\phi_e) = I_D \cdot \sin(\phi_e + 120^\circ) \\ I_W(\phi_e) = I_D \cdot \sin(\phi_e - 120^\circ) \end{cases} \quad (19)$$

4.5.2 FOC2 - Stepper Coil Currents I_X , I_Y and associated Voltages U_X , U_Y

For two-phase motors (stepper) with four terminals UX1, VX2, and WY1, Y2, voltage $U_{Ux} = U_{X1} - U_{X2}$ is in phase with the measured current I_X and $U_{Wy} = U_{Y1} - U_{Y2}$ is in phase with the measured current I_Y according to equations (20) and (21) for FOC2.

$$U_{XY_FOC2} = \begin{cases} U_X(\phi_e) = U_X \cdot \sin(\phi_e) \\ U_Y(\phi_e) = U_Y \cdot \sin(\phi_e + 90^\circ) \end{cases} \quad (20)$$

$$I_{XY_FOC2} = \begin{cases} I_X(\phi_e) = I_D \cdot \sin(\phi_e) \\ I_Y(\phi_e) = I_D \cdot \sin(\phi_e + 90^\circ) \end{cases} \quad (21)$$

4.5.3 FOC1 - DC Motor Coil Current I_{X1} , I_{X2} , and associated Voltage U_{X1} , U_{X2}

For DC motor with two terminals UX1, VX2, voltage $U_X = U_{X1} - U_{X2}$ is in phase (same sign) with the measured current I_X . U_X is in phase (same sign) with the measured current I_X according to equations (22) and (23) for FOC1.

$$U_{XY_FOC1} = U_{X1} - V_{X2} \quad (22)$$

$$I_{XY_FOC1} = I_{X1} \quad (23)$$



4.5.4 ADC Selector & ADC Scaler w/ Offset Correction

The ADC selector selects ADC channels for FOC. The 3-phase FOC uses two ADC channels for measurement and calculates the third channel via Kirchhoff's Law using the scaled and offset-corrected ADC values. The 2-phase FOC just uses two ADC channels because for a 2-phase stepper motor, the two phases are independent from each other.

Note The open-loop encoder is useful for setting up ADC channel selection, scaling, and offset by running a motor open-loop.

The FOC23 Engine processes currents as 16 bit signed (s16) values. Raw ADC values are expanded to 16 bit width, regardless of their resolution. With this, each ADC is available for read out as a 16 bit number. The ADC scaler w/ offset correction is for the preprocessing of measured raw current values. It might be used to map to user's own units (e.g. A or mA). For scaling, gains of current amplifiers, reference voltages, and offsets have to be taken into account.

Info Raw ADC values generally are of 16 bit width, regardless of their real resolution.

Info The ADC scaler maps raw ADC values to the 16 bit signed (s16) range and centers the values to zero by removing offsets.

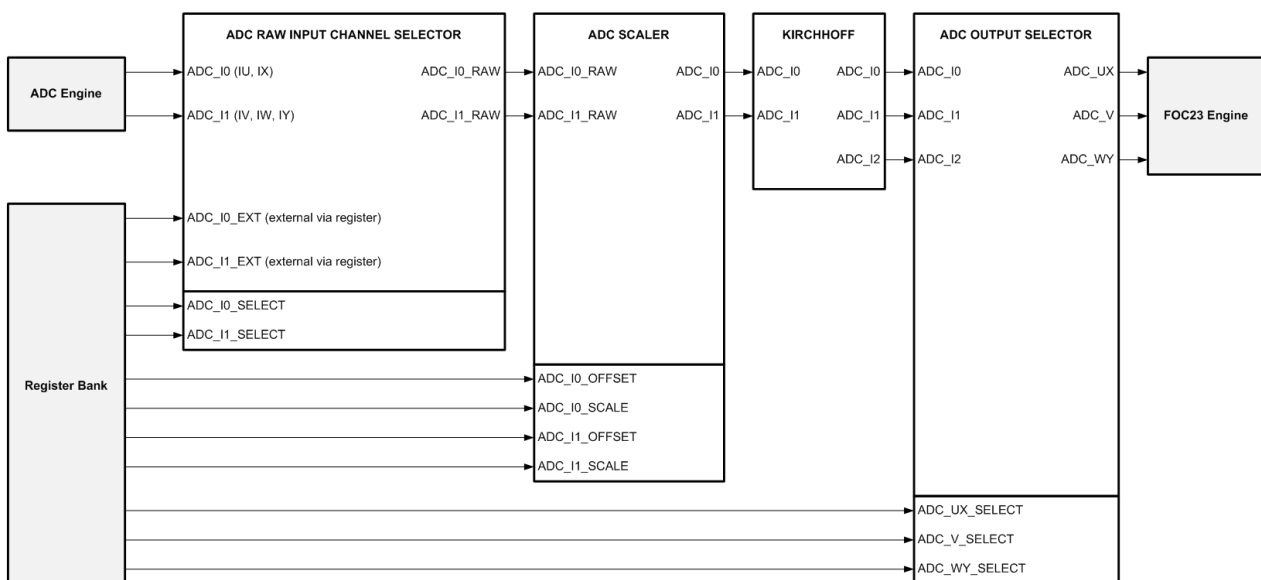

Figure 19: ADC Selector & Scaler w/ Offset Correction

ADC offsets and ADC scalars for the analog current measurement input channels need to be programmed into the associated registers. Each ADC_I_U , ADC_I_V , ADC_I0_EXT , and ADC_I1_EXT are mapped either to ADC_I0_RAW or to ADC_I1_RAW by ADC_I0_SELECT and ADC_I1_SELECT .



In addition, the ADC_OFFSET is for conversion of unsigned ADC values into signed ADC values as required for the FOC. For FOC3, the third current ADC_I2 is calculated via Kirchhoff's Law. This requires the correct scaling and offset correction beforehand. For FOC2, there is no calculation of a third current. The scaling factors ADC_I0_SCALE and ADC_I1_SCALE are displayed in a Q8.8 format which results in the following equations:

$$\text{ADC_I0} = (\text{ADC_I0_RAW} - \text{ADC_I0_OFFSET}) \cdot \text{ADC_I0_SCALE} / 256 \quad (24)$$

$$\text{ADC_I1} = (\text{ADC_I1_RAW} - \text{ADC_I1_OFFSET}) \cdot \text{ADC_I1_SCALE} / 256 \quad (25)$$

The ADC_UX_SELECT selects one of the three ADC channels ADC_I0, ADC_I1, or ADC_I2 for ADC_UX.

The ADC_V_SELECT selects one of the three ADC channels ADC_I0, ADC_I1, or ADC_I2 for ADC_V.

The ADC_WY_SELECT selects one of the three ADC channels ADC_I0, ADC_I1, or ADC_I2 for ADC_WY.

The ADC_UX, ADC_V, and ADC_WY are for the FOC3 (U, V, W).

The ADC_UX and ADC_WY (X, Y) are for the FOC2 (UX, WY).

Note

The open-loop encoder is useful to run a motor open loop for setting up the ADC channel selection with correct association between phase currents I_U, I_V, I_W and phase voltages U_U, U_V, U_W.

4.6 Encoder Engine

The encoder engine is a unified position sensor interface. It maps the selected encoder position information to electrical position (phi_e) and to mechanical position (phi_m). Both are 16 bit values. The encoder engine maps single turn positions from position sensors to multi-turn positions. The user can overwrite the multi-turn position for initialization.

The different position sensors are the position sources for torque and flux control via FOC, for velocity control, and for position control. The PHI_E_SELECTION selects the source of the electrical angle phi_e for the inner FOC control loop. VELOCITY_SELECTION selects the source for velocity measurement. With phi_e selected as source for velocity measurement, one gets the electrical velocity. With the mechanical angle phi_m selected as source for velocity measurement, one gets the mechanical velocity taking the set number of pole pairs (N_POLE_PAIRS) of the motor into account. Nevertheless, for a highly precise positioning, it might be useful to do positioning based on the electrical angle phi_e.

4.6.1 Open-Loop Encoder

For initial system setup, the encoder engine is equipped with an open-loop position generator. This allows for turning the motor open-loop by specifying speed in rpm and acceleration in rpm/s, together with a voltage UD_EXT in D direction. As such, the open-loop encoder is not a real encoder. It simply gives positions as an encoder does. The open-loop decoder has a direction bit to define direction of motion for the application.



Note The open-loop encoder is useful for initial ADC setup, encoder setup, Hall signal validation, and for validation of the number of pole pairs of a motor. The open-loop encoder turns a motor open with programmable velocity in unit [RPM] with programmable acceleration in unit [RPM/s].

With the open-loop encoder, the user can turn a motor without any position sensor and without any current measurement as a first step of doing the system setup. With the turning motor, the user can adjust the ADC scales and offsets and set up positions sensors (Hall, incremental encoder, ...) according to resolution, orientation, and direction of rotation.

4.6.2 Incremental ABN Encoder

The incremental encoders give two phase shifted incremental pulse signals A and B. Some incremental encoders have an additional null position signal N or zero pulse signal Z. An incremental encoder (called ABN encoder or ABZ encoder) has an individual number of incremental pulses per revolution. The number of incremental pulses define the number of positions per revolution (PPR). The PPR might mean pulses per revolution or periods per revolution. Instead of positions per revolution, some incremental encoder vendors call these CPR counts per revolution.

The PPR parameter is the most important parameter of the incremental encoder interface. With that, it forms a modulo (PPR) counter, counting from 0 to (PPR-1). Depending on the direction, it counts up or down. The modulo PPR counter is mapped into the register bank as a dual ported register. The user can overwrite it with an initial position. The ABN encoder interface provides both the electrical position and the multi-turn position, which are accessible through dual-ported read-write registers.

Note The PPR parameter must be set exactly according to the used encoder.

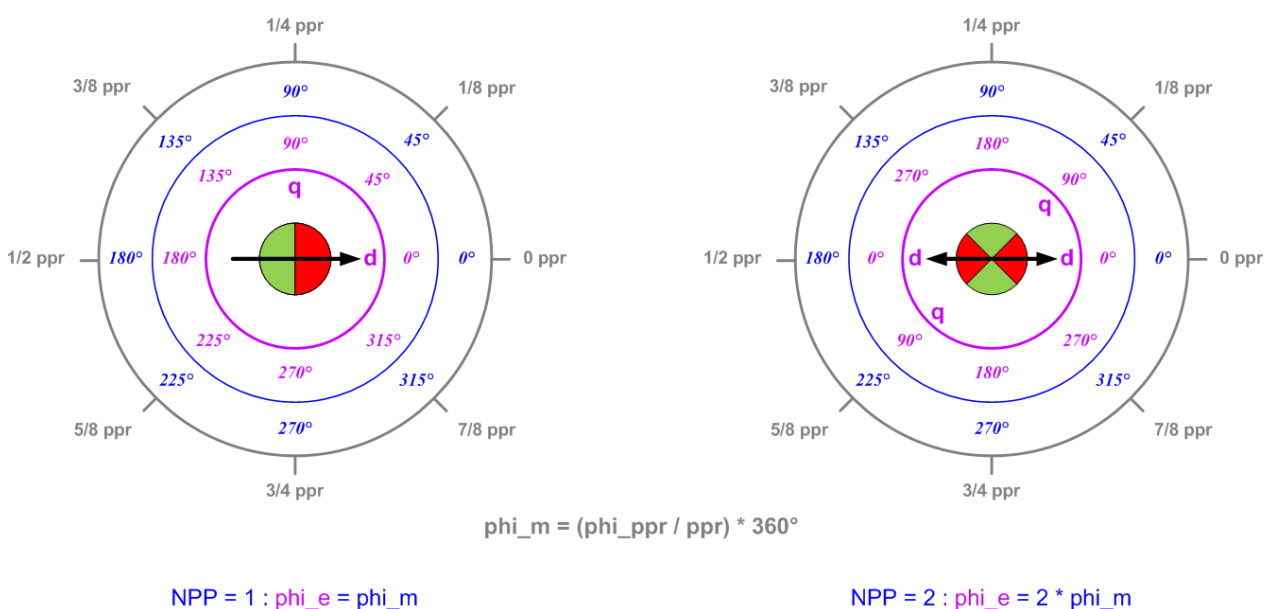

Figure 20: Number of Pole Pairs NPP vs. mechanical angle ϕ_m and electrical angle ϕ_e



The goal of the initialization of an incremental encoder is to set it up so that the magnetic axis of the rotor fits with the electrical angle ϕ_e with the angle zero on D axis. For this, one needs to know the number of pole pairs NPP, the resolution of the incremental encoder in pulses per revolution PPR, and the orientation between measured encoder angle of the rotor and the electrical angle of the field orientation. An encoder measures mechanical angle ϕ_m where the FOC needs the electrical angle ϕ_e for commutation. The number of pole pairs NPP determines the ratio between mechanical angle ϕ_m and electrical angle ϕ_e . The parameters ϕ_m_offset and ϕ_e_offset are for compensation of differences in orientation angle by adjustments.

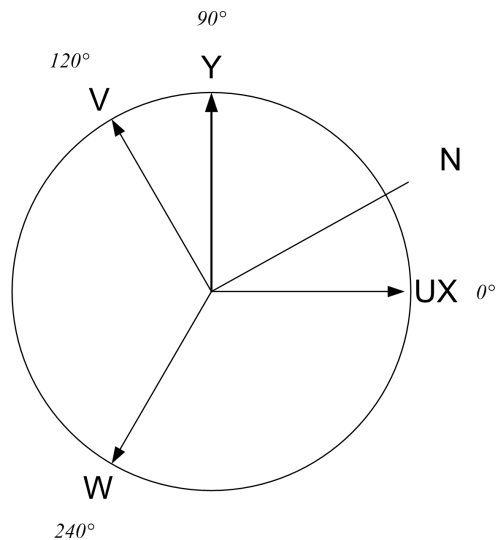

Figure 21: ABN Incremental Encoder N Pulse

The N pulse from an encoder triggers either sampling of the actual encoder count to fetch the position at the N pulse or it re-writes the fetched n position on an N pulse. The N pulse can either be used as stand alone pulse or and-ed with $NAB = N$ and A and B. It depends on the decoder what kind of N pulse has to be used - either N or NAB. For those encoders with precise N pulse within one AB quadrant, the N pulse must be used. For those encoders with N pulse over four AB quadrants the user can enhance the precision of the N pulse position detection by using NAB instead of N.

Note Incremental encoders are available with N pulse and without N pulse.

The polarity of N pulse, A pulse and B pulse are programmable. The N pulse is for re-initialization with each turn of the motor. Once fetched, the ABN decoder can be configured to write back the fetched N pulse position with each N pulse.

Note The ABN encoder interface has a direction bit to set to match wiring of motor to direction of encoder.

Logical ABN = A and B and N might be useful for incremental encoders with low resolution N pulse to enhance the resolution. On the other hand, for incremental encoders with high resolution N pulse a logical ABN = A and B and N might totally suppress the resulting N pulse.



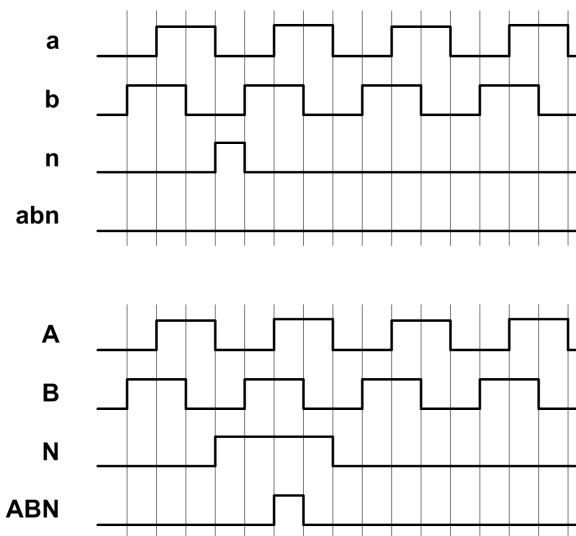

Figure 22: Encoder ABN Timing - high precise N pulse and less precise N pulse

4.6.3 Secondary Incremental ABN Encoder

For commutating a motor with FOC, the user selects a position sensor source (digital incremental encoder, digital Hall, analog Hall, analog incremental encoder, ...) that is mounted close to the motor. The inner FOC loop controls torque and flux of the motor based on the measured phase currents and the electrical angle of the rotor.

The TMC4671 is equipped with a secondary incremental encoder interface. This secondary encoder interface is available as source for velocity control or position control. This is for applications where a motor with a gearing positions an object.

i Info

The secondary incremental encoder is not available for commutation (`phi_e`) for the inner FOC. In others words, there is no electrical angle `phi_e` selectable from the secondary encoder.

4.6.4 Digital Hall Sensor Interface with optional Interim Position Interpolation

The digital Hall interface is the position sensor interface for digital Hall signals. The digital Hall signal interface first maps the digital Hall signals to an electrical position `PHI_E_RAW`. An offset `PHI_E_OFFSET` can be used to rotate the orientation of the Hall signal angle. The electrical angle `PHI_E` is for commutation. Optionally, the default electrical positions of the Hall sensors can be adjusted by writes into the associated registers.



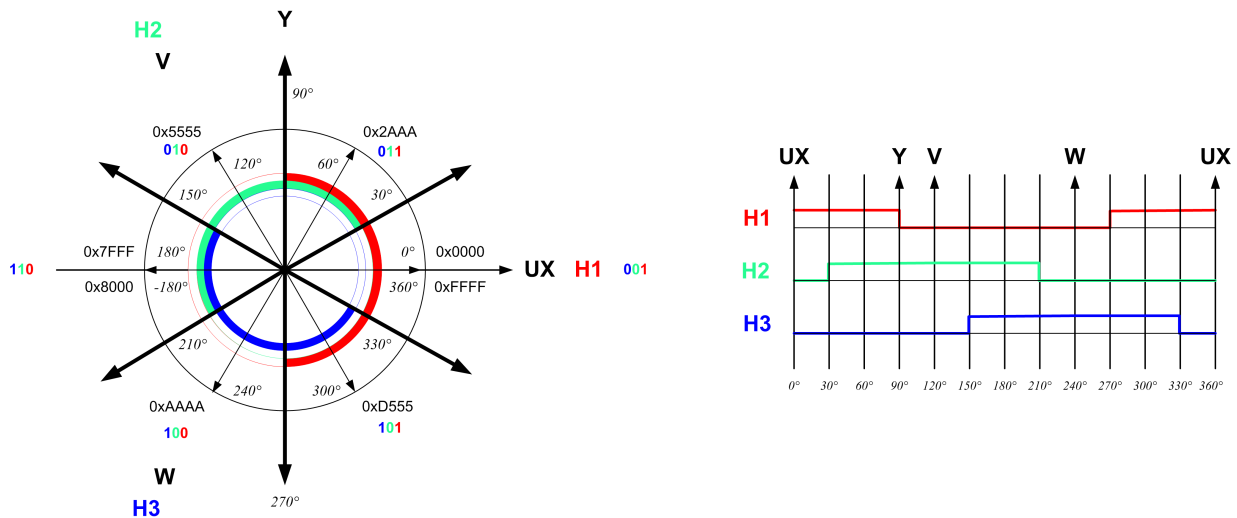

Figure 23: Hall Sensor Angles

Hall sensors give absolute positions within an electrical period with a resolution of 60° as 16 bit positions (s16 resp. u16) PHI. With activated interim Hall position interpolation, the user gets high resolution interim positions when the motor is running at a speed above 60 rpm.

4.6.5 Digital Hall Sensor - Interim Position Interpolation

For lower torque ripple the user can switch on the position interpolation of interim Hall positions. This function is useful for motors that are compatible with sine wave commutation, but equipped with digital Hall sensors. When the position interpolation is switched on, it becomes active on speeds above 60 rpm. For lower speeds it automatically disables itself. This is especially important when the motor has to be at rest. Hall sensor position interpolation might fail when Hall sensors are not properly placed in the motor. Please adjust Hall sensor positions for this case.

4.6.6 Digital Hall Sensors - Masking, Filtering, and PWM center sampling

Sometimes digital Hall sensor signals get disturbed by switching events in the power stage. The TMC4671 can automatically mask switching distortions by correct setting of the HALL_MASKING register. When a switching event occurs, the Hall sensor signals are held for HALL_MASKING value times 10 ns. This way, Hall sensor distortions are eliminated.

Uncorrelated distortions can be filtered via a digital filter of configurable length. If the input signal to the filter does not change for HALL_DIG_FILTER_LENGTH times 5 us, the signal can pass the filter. This filter eliminates issues with bouncing Hall signals. naming with Elliot: Masking is better then Blanking

Spikes on Hall signals (Hx that stands for H1, H2, H3) disturb the FOC loop when Hall signals are used for commutation or for initialization of incremental encoders. Spikes on hall signal lines might occur when Hall signals are feed on singled ended signal lines in parallel to motor power lines due to electromagnetic cross talk in a single cable. Long Hall signal lines might cause digital Hall signal cross talk even in separate fed cables. Cables that provide Hall signals without spikes should be preferred. A good ground for digital Hall signals is important for clean Hall signals. A good ground shield of the motor might help for clean Hall signals. In best case, Hall signals are fed within separate shielded signal lines together with differential line drivers.



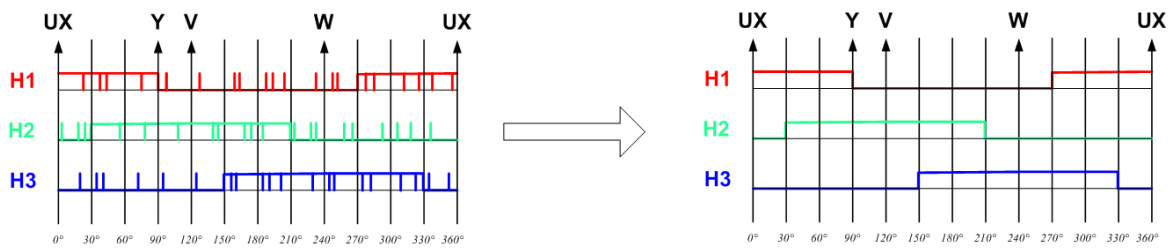

Figure 24: Outline of noisy Hall signals (left) due to electromagnetic interference with PWM switching and noise cleaned Hall signals (right) by PWM center synced sampling of Hall signal vector (H1 H2 H3)

The best is avoiding spikes on digital Hall signals. Nevertheless, to enable lower cost motors with lower performance Hall signal shielding, the TMC4671 is equipped with Hall Signal spike suppression and PWM centered Hall signal vector sampling.

To reduce possible current ripple that might be caused by noisy Hall signals, the sampling of the Hall signal vector can be programmed for sampling once per PWM period at its center for the desired noise reduction. The PWM centered Hall signal sampling is programmable by HALL_MODE(4) control bit. Continuous sampling is default. This function is not available for TMC4671-ES engineering samples.

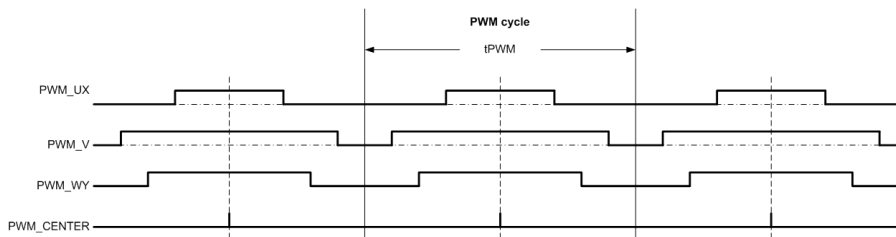

Figure 25: Hall Signal PWM Center Sampling on PWM_CENTER

The PWM center synchronization needs to be qualified for high speed applications due to reduction of Hall signals for PWM frequency. The PWM center might have an influence on Hall signal interpolation and needs to be qualified if Hall signal interpolation is enabled.

For additional spike suppression, the TMC4671 is equipped with a digital hall signal blanking, to support lower performance cabling environments. The blank time for the Hall signals is programmable (HALL_BLANK) in steps of 10 ns from 0 ns up to 4095 ns. The Hall signal blanking time should be programmed as long as necessary for safe suppression of spikes of maximum duration. On the other side, the Hall signal blanking should be programmed as short as possible to avoid disturbance by too strong filtering that might also disturb the FOC.

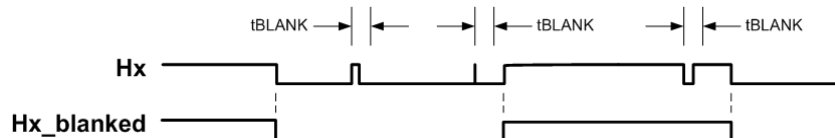

Figure 26: Hall Signal Blanking



4.6.7 Digital Hall Sensors together with Incremental Encoder

If a motor is equipped with both Hall sensors and incremental encoder, the Hall sensors can be used for the initialization as a low resolution absolute position sensor. Later on, the incremental encoder can be used as a high resolution sensor for commutation.

4.6.8 Analog Hall and Analog Encoder Interface (SinCos of 0° 90° or 0° 120° 240°)

An analog encoder interface is part of the decoder engine. It is able to handle analog position signals of 0° and 90° and of 0° 120° 240°. The analog decoder engine adds offsets and scales the raw analog encoder signals, while also calculating the electrical angle PHI_E from these analog position signals by an ATAN2 algorithm.

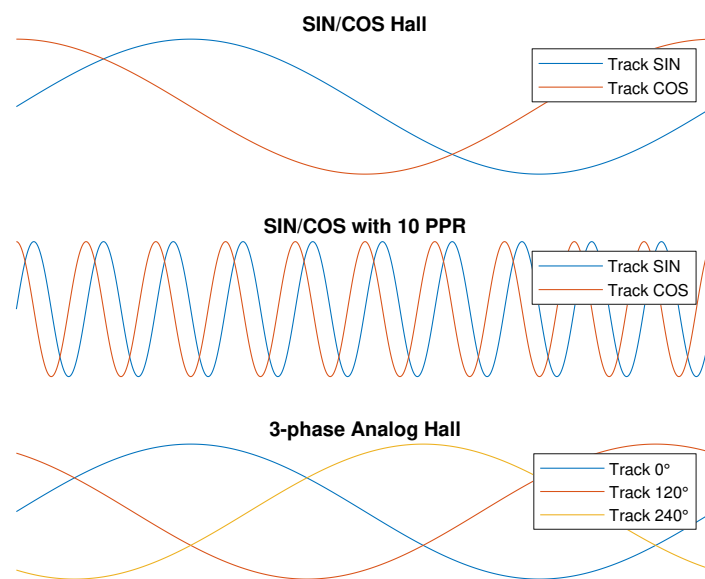

Figure 27: Analog Encoder (AENC) signal waveforms

An individual signed offset is added to each associated raw ADC channel and scaled by its associated scaling factors according to

$$\text{AENC_VALUE} = (\text{AENC_RAW} + \text{AENC_OFFSET}) \cdot \text{AENC_SCALE} \quad (26)$$

In addition, the AENC_OFFSET is for conversion of unsigned ADC values into signed ADC values as required for the FOC.

i Info

The control bit 0 in register AENC_DECODER_MODE (0x3B) selects either processing of analog position signals of 0° and 90° (0b0) or analog signals of 0° 120° 240° on (0b1).



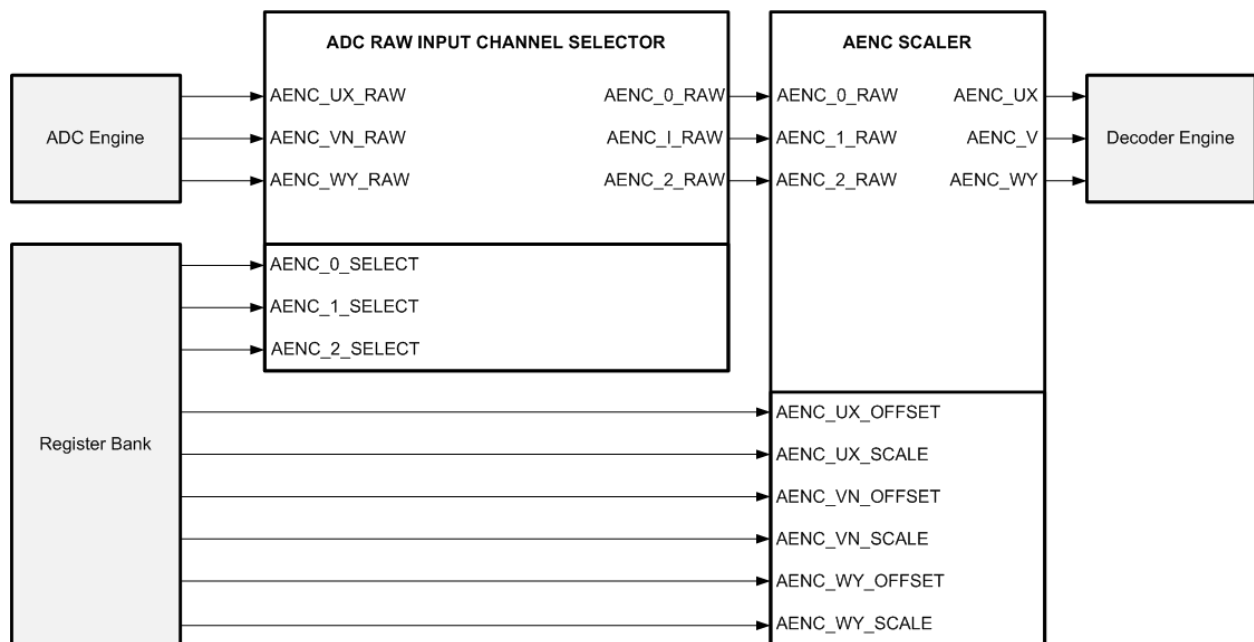

Figure 28: Analog Encoder (AENC) Selector & Scaler w/ Offset Correction

In Fig. 27 possible waveforms are shown. The graphs show usual SIN/COS track signals with one and multiple periods per revolution as well as typical waveforms of three phase analog Hall signals for one electrical revolution. The number of periods per revolution can be configured by register AENC_DECODER_PPR. The position in one period (AENC_DECODER_PHI_A) is calculated by an ATAN2 algorithm. The periods are counted with respect to the number of periods per revolution to calculate AENC_DECODER_PHI_E and AENC_DECODER_PHI_M. If PPR is the same as the number of pole pairs, AENC_DECODER_PHI_E and AENC_DECODER_PHI_A are identical. This is usually the case for analog hall signals.

i Info

The analog N pulse is just a raw ADC value. Handling of analog N pulse similar to N pulse handling of digital encoder N pulse is not implemented for analog encoder.

4.6.9 Analog Position Decoder (SinCos of 0°90° or 0°120°240°)

The extracted positions from the analog decoder are available for read out from registers.

4.6.9.1 Multi-Turn Counter

Electrical angles are mapped to a multi-turn position counter. The user can overwrite this multi-turn position for initialization purposes.

4.6.9.2 Encoder Engine Phi Selector

The angle selector selects the source for the commutation angle PHI_E. That electrical angle is available for commutation.



4.6.9.3 External Position Register

A register value written into the register bank via the application interface is available for commutation as well. With this, the user can interface to any encoder by just writing positions extracted from external encoder into this regulator. From the decoder engine point of view this is just one more selectable encoder source.

4.6.10 Encoder Initialization Support

The TMC4671 needs proper feedback for correct and stable operation. One main parameter is the commutation angle offset `PHI_E_OFFSET`. This offset must not be calculated when an absolute sensor system like analog or digital Hall sensors is used. All other supported feedback systems need to be initialized - their `PHI_E_OFFSETs` need to be identified. The user has several options to determine `PHI_E_OFFSET` with support of the TMC4671.

4.6.10.1 Encoder Initialization in Open-Loop Mode

In the case of a free driving motor, the motor can be switched to Open-Loop Mode. In this mode, the used commutation angle (`PHI_OPEN_LOOP`) can be used to match the measured `PHI_E`. This method is supported by the `TMCL-IDE`.

4.6.10.2 Encoder Initialization by Hall sensors

The TMC4671 can calculate `PHI_E_OFFSET` very precisely at a Hall state change for a second encoder system, when Hall sensors are correctly aligned. Therefore, the function needs to be enabled and calculate a new offset at the next Hall state change. After disabling of the module, the process can be started again. This function can also be used as a rough plausibility check during longer operation.

4.6.10.3 Encoder Initialization by N Pulse Detection

After determination of a correct offset, the value can be used again after power cycle. The encoder's N pulse can be used as reference for this. For starters the user can drive the motor in open-loop mode or by using digital Hall sensor signals. After passing the encoder's N pulse, the ABN encoder is initialized and can be used for operation.

4.6.11 Velocity Measurement

Servo control comprises position, velocity and current control. The position and the current are measured by separate sensors. The actual velocity has to be calculated by time discrete differentiation from the position signal. The user can choose a calculated position from the various encoder interfaces for velocity measurement by parameter `VELOCITY_SELECTION`.

The user can switch between two different velocity calculation algorithms with the parameter `VELOCITY_METER_SELECTION`. Default setting (`VELOCITY_METER_SELECTION = 0`) is the standard velocity meter, which calculates the velocity at a sampling rate of about 4369.067 Hz by differentiation. Output value is displayed in rpm (revolutions per minute). This option is recommended for usage with the standard PI controller structure.

By choosing the second option (`VELOCITY_METER_SELECTION = 1`), the sampling frequency is synchronized to the PWM frequency. This option is recommended for usage with the advanced PI controller structure. Otherwise, the controller structure might tend to be unstable due to non-matched sampling. Velocity filters can be applied to reduce noise on velocity signals. Section 4.8 describes filtering opportunities in detail.



4.6.12 Reference Switches

The TMC4671 is equipped with three input pins for reference switches (REF_SW_L, REF_SW_H and REF_SW_R). These pins can be used to determine three reference positions. The TMC4671 displays the status of the reference switches in the register TMC_INPUTS_RAW and is able to store the actual position at rising edge of the corresponding signal. The signal polarities are programmable and the module reacts only on toggling the ENABLE register. The signals can be filtered with a configurable digital filter, which suppresses spike errors.

With the STATUS_FLAGS and STATUS_MASK register the STATUS output can be configured as an IRQ for passing a reference switch.

The actual position can be latched when passing a reference switch. The latched positions are displayed in registers HOME_POSITION, LEFT_POSITION, and RIGHT_POSITION. The position latching can be enabled with REF_SWITCH_ENABLE. The polarity of each Reference switch can be changed with corresponding polarity registers HOME_SWITCH_POLARITY, LEFT_SWITCH_POLARITY, and RIGHT_SWITCH_POLARITY. If a reference switch is passed the corresponding status bit (HOME_SWITCH_PASSED, LEFT_SWITCH_PASSED, and RIGHT_SWITCH_PASSED) is enabled. With disabling of the latching function the status bits are cleared.

i Info

The polarity registers do not affect the status registers. The status flag only represents the current logical state of the switch.



4.7 FOC23 Engine

The FOC23 engine performs the inner current control loop for the torque current I_Q and the flux current I_D including the required transformations. Programmable limiters take care of clipping of interim results. Per default, the programmable circular limiter clips U_D and U_Q to $U_{D_R} = \sqrt{(2)} \cdot U_Q$ and $U_{R_R} = \sqrt{(2)} \cdot U_D$. PI controllers perform the regulation tasks. Please make sure to enable controllers by pulling ENI pin to high level.

4.7.1 ENI and ENO pins

The ENI (Enable input) can be used to start and stop control action. During reset ENO (Enable out) is low and afterwards it forwards ENI signal. Thereby it can be used to enable the power stage. When ENI is low, all controllers are deactivated and PWM operates at 50% duty cycle. ENI input value can be read through TMC4671_INPUTS_RAW register.

4.7.2 PI Controllers

PI controllers are used for current control and velocity control. A P controller is used for position control. The derivative part is not yet supported but might be added in the future. The user can choose between two PI controller structures: The classic PI controller structure, which is also used in the TMC4670, and the advanced PI controller structure. The advanced PI controller structure shows better performance in dynamics and is recommended for high performance applications. User can switch between controllers by setting register MODE_PID_TYPE. Controller type can not be switched individually for each cascade level.

4.7.3 PI Controller Calculations - Classic Structure

The PI controllers in the classic structure perform the following calculation

$$Y = P \cdot e + I \cdot \int_0^t e(t) dt \quad (27)$$

with

$$e = X_TARGET - X \quad (28)$$

where X_TARGET stands for target flux (s16), target torque (s16), target velocity (s32), or target position (s32) with error e, which is the difference between target value and actual values. The Y stands for the output of the PI controller feed as target input to the successive PI controller of the FOC servo controller cascade (position → PI → velocity → PI → current → PI → voltage).

Y_PID_FLUX	=	PID_FLUX_P	*	ERROR_FLUX / 256
Y_PID_FLUX_RATE	=	PID_FLUX_I	*	ERROR_FLUX / 65536 / (32 μs)
Y_PID_TORQUE	=	PID_FLUX_P	*	ERROR_TORQUE / 256
Y_PID_TORQUE_RATE	=	PID_TORQUE_I	*	ERROR_TORQUE / 65536 / (32 μs)
Y_PID_VELOCITY	=	PID_VELOCITY_P	*	ERROR_VELOCITY / 256
Y_PID_VELOCITY_RATE	=	PID_VELOCITY_I	*	ERROR_VELOCITY / 65536 / (256 μs)



$$Y_PID_POSITION = PID_POSITION_P * ERROR_POSITION / 65536$$

$$Y_PID_POSITION_RATE = PID_POSITION_I * ERROR_POSITION / 65536 / (256 \mu s)$$

Table 20: Scalings and Change Rate Timings of PID controllers (classic structure) for currents, velocity, and position for clock frequency $f_{CLK} = 25MHz$

Number	Motion Mode	Description
0	Stopped Mode	Disabling all controllers
1	Torque Mode	Standard Torque Control Mode
2	Velocity Mode	Standard Velocity Control Mode
3	Position Mode	Standard Position Control Mode
4	PRBS Flux Mode	PRBS Value is used as Target Flux Value for Ident.
5	PRBS Torque Mode	PRBS Value is used as Target Torque Value for Ident.
6	PRBS Velocity Mode	PRBS Value is used as Target Velocity Value for Ident.
7	PRBS Position Mode	PRBS Value is used as Target Position Value for Ident.
8	UQ UD Ext Mode	Voltage control mode (Software Mode)
9	reserved	reserved
10	AGPI_A Torque Mode	AGPI_A used as Target Torque value
11	AGPI_A Velocity Mode	AGPI_A used as Target Velocity value
12	AGPI_A Position Mode	AGPI_A used as Target Position value
13	PWM_I Torque Mode	PWM_I used as Target Torque value
14	PWM_I Velocity Mode	PWM_I used as Target Velocity value
15	PWM_I Position Mode	PWM_I used as Target Position value

Table 21: Motion Modes



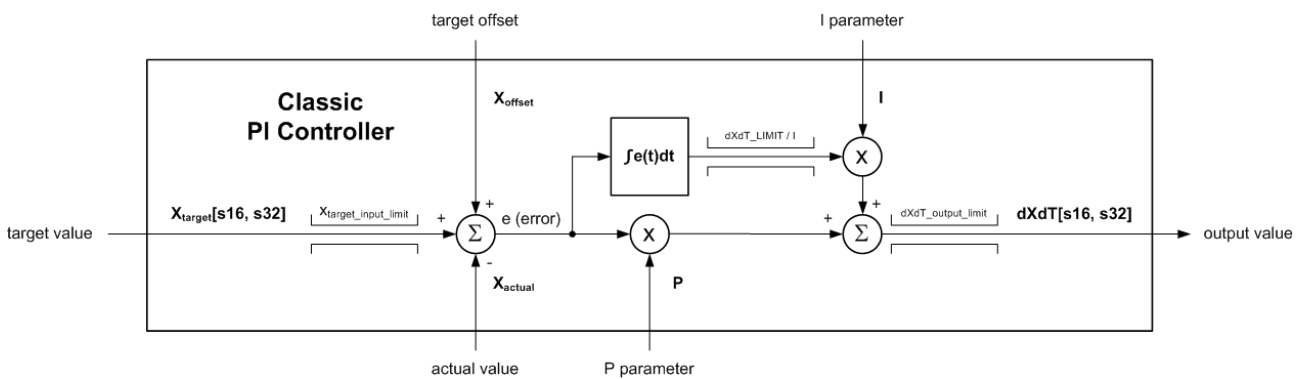

Figure 29: Classic PI Controller

Info

Changing the I-parameter of the classic PI controller during operation causes the controller output to jump, as the control error is first integrated and then gained by the I parameter. Jumps can be avoided by incremental changes of I-parameter.

Info

Support for the TMC4671 is integrated into the TMCL-IDE including wizards for set up and configuration. With the TMCL-IDE, configuration and operation can be done in a few steps and the user gets direct access to all registers of the TMC4671.

4.7.4 PI Controller Calculations - Advanced Structure

The PI controllers in the advanced controller structure perform the calculation

$$dXdT = P \cdot e + \int_0^t P \cdot I \cdot e(t) dt \quad (29)$$

with

$$e = X_TARGET - X \quad (30)$$

where X_TARGET represents target flux, target torque, target velocity, or target position with control error e, which is the difference between target value and actual values. The time constant dt is set according to the PWM period but can be downsampled for the position controller by register MODE_PID_SMPL. Position controller evaluation can be downsampled by a constant factor when needed.



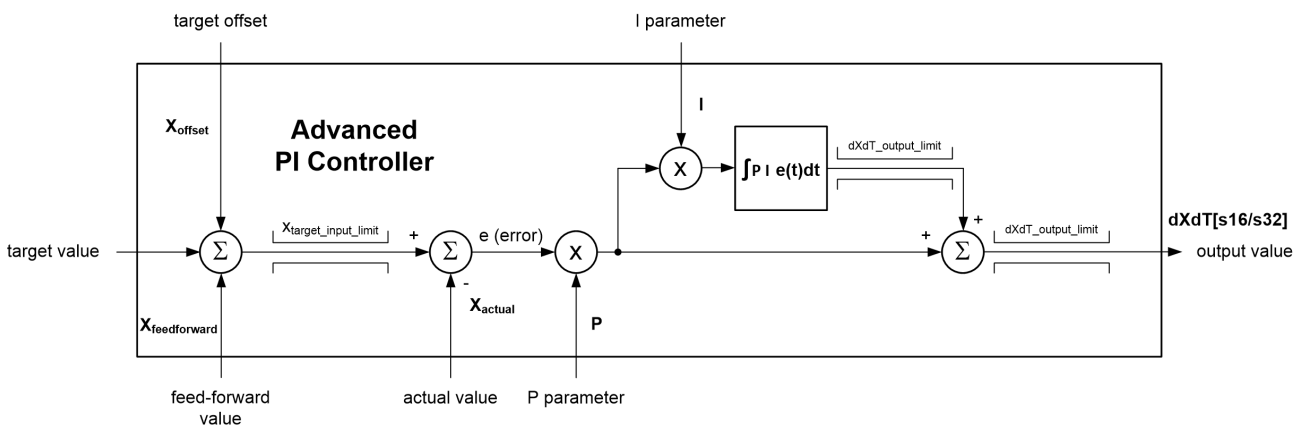

Figure 30: Advanced PI Controller

Info

The P Factor normalization as Q8.8 of the advanced PI controller of the TMC4671-ES is selectable for the TMC4671-LA as either Q8.8 or Q4.12. This can be configured in register 0x4D CONFIG_DATA when register 0x4E CONFIG_ADDR is set to 0x3E. For more information refer to section 7.2. Using Q4.12 needs changes in the user's application controller software when using the Advanced PI position controller.

The transfer function of the advanced PI controller can be described by the following pseudo code:

$$\begin{aligned} dXdT &= e \cdot P + \text{integrator} \\ \text{integrator} &= \text{integrator} + P \cdot I \cdot e \end{aligned} \quad (31)$$

P and I are either displayed as Q8.8 ($P = P_FAK/256$) or Q4.12 ($P = P_FAK/4096$). This is individually configurable for each controller parameter in the controller cascade.

Downsampling of the advanced position controller can be configured by register MODE_PID_SMPL. When the register is 0 the controllers will sample on the PWM-frequency f_{PWM} . The new samplerate will be derived from f_{PWM} and the downsampling-value assigned to register MODE_PID_SMPL (range: 0 to 127). The derived sampling frequency is calculated as follows:

$$\text{Samplerate}_{\text{new}} = \frac{f_{\text{PWM}}}{\text{downsampling} + 1} \quad (32)$$

4.7.5 PI Controller - Clipping

The limiting of target values for PI controllers and output values of PI controllers is programmable. Per power on default these limits are set to maximum values. During initialization, these limits should be set properly for correct operation and clipping.

The target input is clipped to X_TARGET_LIMIT . The output of a PI controller is named $dXdT$ because it gives the desired derivative d/dt as a target value to the following stage: The position (x) controller gives velocity (dx/dt). The output of the PI Controller is clipped to $dXdT_LIMIT$. The error integral of (27) is clipped to $dXdT_LIMIT / I$ in the classic controller structure, and the integrator output is clipped to $dXdT_output_limit$ in the advanced controller structure.



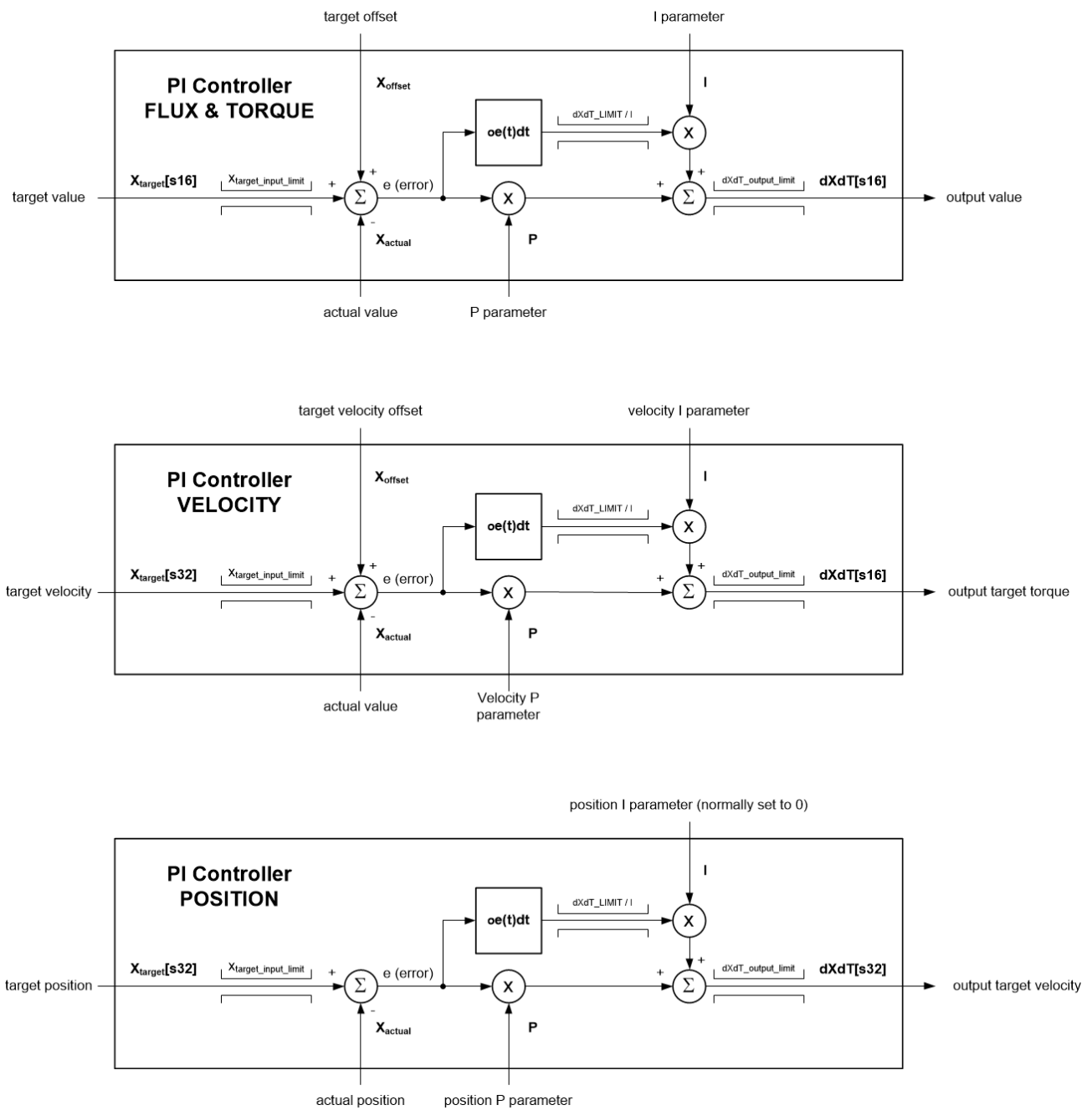

Figure 31: PI Controllers for position, velocity and current

4.7.6 PI Flux & PI Torque Controller

The P part is represented as q8.8 and I is the I part represented as q0.15.

4.7.7 PI Velocity Controller

The P part is represented as q8.8 and I is the I part represented as q0.15.



4.7.8 P Position Controller

For the position regulator, the P part is represented as q4.12 to be compatible with the high resolution positions - one single rotation is handled as an s16. For the advanced controller structure the P part is represented by q8.8.

4.7.9 Inner FOC Control Loop - Flux & Torque

The inner FOC loop (figure 32) controls the flux current to the flux target value and the torque current to the desired torque target. The inner FOC loop performs the desired transformations according to figure 33 for 3-phase motors (FOC3). For 2-phase motors (FOC2) both Clarke (CLARKE) transformation and inverse Clarke (iCLARKE) are bypassed. For control of DC motors, transformations are bypassed and only the first full bridge (connected to X1 and X2) is used.

The inner FOC control loop gets a target torque value (I_Q_TARGET) which represents acceleration, the rotor position, and the measured currents as input data. Together with the programmed P and I parameters, the inner FOC loop calculates the target voltage values as input for the PWM engine.

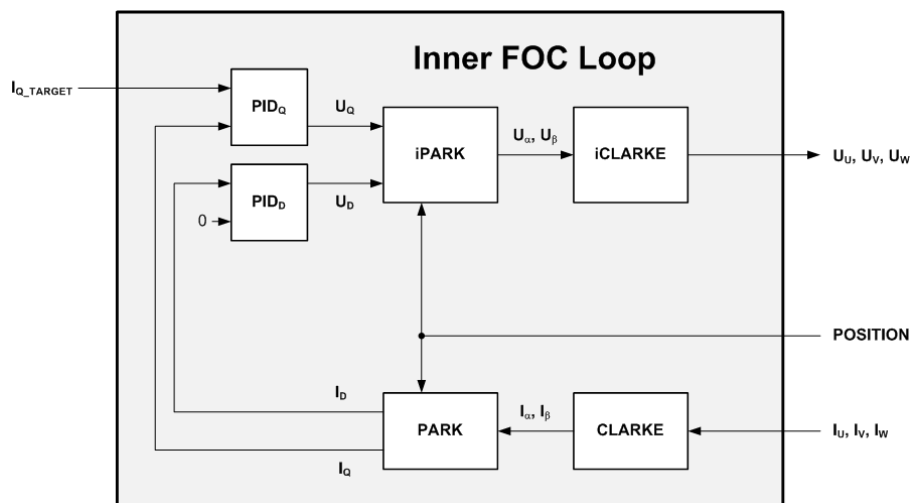

Figure 32: Inner FOC Control Loop

4.7.10 FOC Transformations and PI(D) for control of Flux & Torque

The Clarke transformation (CLARKE) maps three motor phase currents (I_U, I_V, I_W) to a two-dimensional coordinate system with two currents (I_α, I_β). Based on the actual rotor angle determined by an encoder or via sensorless techniques, the Park transformation (PARK) maps these two currents to a quasi-static coordinate system with two currents (I_D, I_Q). The current I_D represents flux and the current I_Q represents torque. The flux just pulls on the rotor but does not affect torque. The torque is affected by I_Q . Two PI controllers determine two voltages (U_D, U_Q) to drive desired currents for a target torque and a target flux. The determined voltages (U_D, U_Q) are re-transformed into the stator system by the inverse Park transformation (iPARK). The inverse Clarke Transformation (iCLARKE) transforms these two currents into three voltages (U_U, U_V, U_W). These three voltage are the input of the PWM engine to drive the power stage.

In case of the FOC2, Clarke transformation CLARKE and inverse Clarke Transformation iCLARKE are skipped.



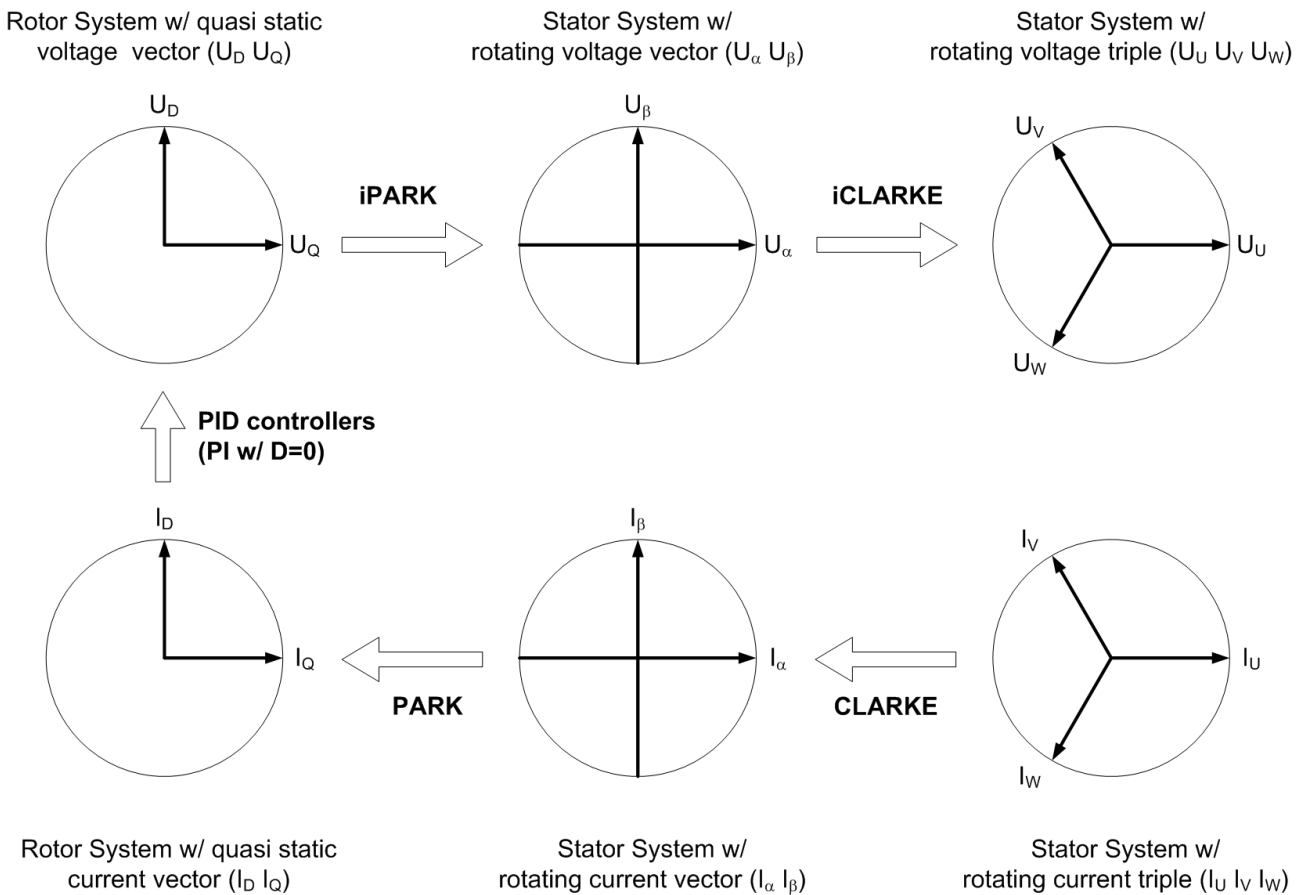

Figure 33: FOC3 Transformations (FOC2 just skips CLARKE and iCLARKE)

4.7.11 Motion Modes

The user can operate the TMC4671 in several motion modes. Standard motion modes are position control, velocity control and torque control, where target values are fed into the controllers via register access. The motion mode UD_UQ_EXTERN allows the user to set voltages for open-loop operation and for tests during setup.

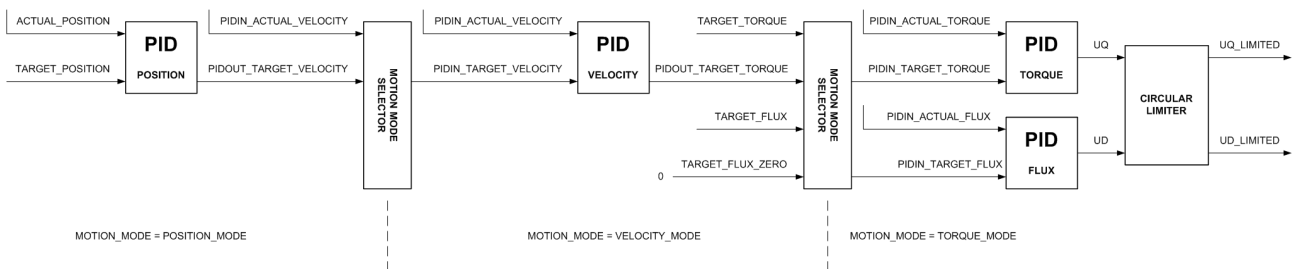

Figure 34: Standard Motion Modes

In position control mode, the user can feed the step and direction interface to generate a position target value for the controller cascade. In additional motion modes target values are fed into the TMC4671 via PWM interface (Pin: PWM_IN) or analog input via pin AGPI_A.



There are additional motion modes, which are using input from the PWM_I input or the AGPI_A input. Input signals can be scaled via a standard scaler providing offset and gain correction. The interface can be configured via the registers SINGLE_PIN_IF_OFFSET_SCALE and SINGLE_PIN_IF_STATUS_CFG, where the status of the interface can be monitored as well. PWM input signals which are out of frequency range can be neglected. In case of wrong input data, last correct position is used or velocity and torque are set to zero.

Number	Motion Mode	Description
0	Stopped Mode	Disabling all controllers
1	Torque Mode	Standard Torque Control Mode
2	Velocity Mode	Standard Velocity Control Mode
3	Position Mode	Standard Position Control Mode
4	PRBS Flux Mode	PRBS Value is used as Target Flux Value for Ident.
5	PRBS Torque Mode	PRBS Value is used as Target Torque Value for Ident.
6	PRBS Velocity Mode	PRBS Value is used as Target Velocity Value for Ident.
7	PRBS Position Mode	PRBS Value is used as Target Position Value for Ident.
8	UQ UD Ext Mode	Voltage control mode (Software Mode)
9	reserved	reserved
10	AGPI_A Torque Mode	AGPI_A used as Target Torque value
11	AGPI_A Velocity Mode	AGPI_A used as Target Velocity value
12	AGPI_A Position Mode	AGPI_A used as Target Position value
13	PWM_I Torque Mode	PWM_I used as Target Torque value
14	PWM_I Velocity Mode	PWM_I used as Target Velocity value
15	PWM_I Position Mode	PWM_I used as Target Position value

Table 22: Motion Modes

4.7.12 Brake Chopper

During regenerative braking of the motor, current is driven into the DC link. If the power frontend is not actively controlled, the DC link voltage will rise. The brake chopper output pin (BRAKE) can be used for control of an external brake chopper, which burns energy over a brake resistor. The BRAKE pin is set to high for a complete PWM cycle if measured voltage is higher than ADC_VM_LIMIT_HIGH. Once active it will be deactivated when voltage drops below ADC_VM_LIMIT_LOW. This acts like a hysteresis. BRAKE can be deactivated by setting both registers to Zero. By setting proper values in the registers it is automatically enabled.



4.8 Filtering and Feed-Forward Control

The TMC4671 uses different filters for certain target and actual values. When using standard velocity meter, a standard velocity filter is used which is optimized for velocity signals from Hall sensors. Additional Biquad filters can be used to suppress measurement noise or damp resonances.

4.8.1 Biquad Filters

The TMC4671 uses standard biquad filters (standard IIR filter of second order, [Wikipedia Article](#)) in the following structure.

$$Y(n) = X(n) \cdot b_0 + X(n-1) \cdot b_1 + X(n-2) \cdot b_2 + Y(n-1) \cdot a_1 + Y(n-2) \cdot a_2 \quad (33)$$

In this equation $X(n)$ is the actual input sample, while $Y(n-1)$ is the filter output of the last cycle. All coefficients are S32 values and are normalized to a Q3.29 format. Users must take care of correct parametrization of the filter. There is no built-in plausibility or stability check. All filters can be disabled or enabled via register access. Biquad state variables are reset when parameters are changed. The TRINAMIC IDE supports parametrization with wizards.

A standard biquad filter has the following transfer function in the Laplace-Domain:

$$G(s) = \frac{b_2_cont \cdot s^2 + b_1_cont \cdot s + b_0_cont}{a_2_cont \cdot s^2 + a_1_cont \cdot s + a_0_cont} \quad (34)$$

The transfer function needs to be transformed to time discrete domain by Z-Transformation and coefficients need to be normalized. This is done by the following equations.

$$b_2_z = (b_0_cont \cdot T^2 + 2 \cdot b_1_cont \cdot T + 4 \cdot b_2_cont) / (T^2 - 2 \cdot a_1_cont \cdot T + 4 \cdot a_2_cont) \quad (35)$$

$$b_1_z = (2 \cdot b_0_cont \cdot T^2 - 8 \cdot b_2_cont) / (T^2 - 2 \cdot a_1_cont \cdot T + 4 \cdot a_2_cont) \quad (36)$$

$$b_0_z = (b_0_cont \cdot T^2 - 2 \cdot b_1_cont \cdot T + 4 \cdot b_2_cont) / (T^2 - 2 \cdot a_1_cont \cdot T + 4 \cdot a_2_cont) \quad (37)$$

$$a_2_z = (T^2 + 2 \cdot a_1_cont \cdot T + 4 \cdot a_2_cont) / (T^2 - 2 \cdot a_1_cont \cdot T + 4 \cdot a_2_cont) \quad (38)$$

$$a_1_z = (2 \cdot T^2 - 8 \cdot a_2_cont) / (T^2 - 2 \cdot a_1_cont \cdot T + 4 \cdot a_2_cont) \quad (39)$$

$$b_0 = \text{round}(b_0_z \cdot 2^{29}) \quad (40)$$

$$b_1 = \text{round}(b_1_z \cdot 2^{29}) \quad (41)$$

$$b_2 = \text{round}(b_2_z \cdot 2^{29}) \quad (42)$$

$$a_1 = \text{round}(-a_1_z \cdot 2^{29}) \quad (43)$$

$$a_2 = \text{round}(-a_2_z \cdot 2^{29}) \quad (44)$$

while T is the sampling time according to $\text{PWM_MAX_COUNT} \cdot 10 \text{ ns}$ and variables with index z are auxiliary variables.

A standard second order lowpass filter with given cutoff frequency ω_c and damping factor D has the following transfer function in the Laplace-Domain:

$$G_{LP}(s) = \frac{1}{\frac{1}{\omega_c^2} \cdot s^2 + \frac{2D}{\omega_c} \cdot s + 1} \quad (45)$$

Users can determine filter coefficients with the upper equations by comparing coefficients of both transfer functions. The TMCL-IDE also provides a dimensioning tool.

There are four biquad filters in the control structure. Figure 35 illustrates their placement in the control structure.



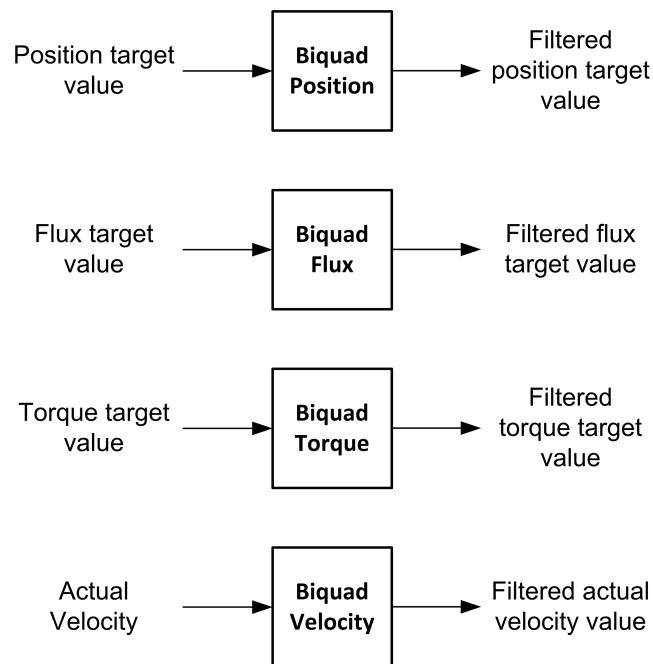

Figure 35: Biquad Filters

The biquad filter for the position target value is intended to be used as a low-pass filter for smoothing position input to the control structure. It is evaluated in every PWM cycle, or down-sampled according to the down-sampling factor for the position controller. After powering on it is disabled.

The biquad filter for the flux target value is also intended to be used as a low-pass filter for input values from the user's microcontroller. Sampling frequency is fixed to the PWM frequency.

The biquad filter for the torque target value can be used as a low-pass filter for bandwidth limitation and noise suppression. Moreover, it can be designed to suppress a resonance or anti-resonance. Same statements are correct for the velocity biquad filter. Both filters' sampling times are fixed to the PWM period.

The velocity target value biquad is configured as a second order low-pass with a cutoff frequency at 200 Hz - by default at a sampling frequency of 25 kHz. Biquad filters can be activated separately.

4.8.2 Standard Velocity Filter

By using the standard velocity measurement algorithm, the default velocity filter is enabled and can not be switched off. The standard velocity filter is a low-pass filter with a cutoff frequency of 20 Hz (slope of -20 dB/Decade). In this configuration, a new velocity is calculated at a sample rate of approx. 4369.067 Hz. This configuration is intended to be used in low-performance applications with a simple position feedback system like digital Hall sensors.

4.8.3 Feed-Forward Control Structure

Note

Software feed forward control via offset registers is recommended, due to missing amplification possibility. Utilize feedforward to actively increase the target value of a controller besides the normal target input. For Torque/Flux use register 0x65 PID_TORQUE_FLUX_OFFSET and for the velocity use register 0x67 PID_VELOCITY_OFFSET.



4.9 PWM Engine

The PWM engine takes care of converting voltage vectors to pulse width modulated (PWM) control signals. These digital PWM signals control the gate drivers of the power stage. For a detailed description of the PWM control registers and PWM register control bits pls. refer section 7 page 71.

The ease-of-use PWM engine requires just a couple of parameter settings. Primarily, the polarities for the gate control signal of high-side and low-side must be set. The power on default PWM mode is 0, meaning PWM = OFF. For operation, the centered PWM mode must be switched on by setting the PWM mode to 7. A single bit switches the space vector PWM (SVPWM) on. For 3-phase PMSM, the SVPWM = ON gives more effective voltage. Nevertheless, for some applications it makes sense to switch the SVPWM = OFF to keep the star point voltage of a motor almost at rest.

4.9.1 PWM Polarities

The PWM polarities register (PWM_POLARITIES) controls the polarities of the logic level gate control signals. The polarities of the gate control signals are individually programmable for low-side gate control and for high-side gate control. The PWM polarities register controls the polarity of other control signals as well. PWM_POLARITIES[1] controls the polarity of the logic level high side gate control signal. PWM_POLARITIES[0] controls the polarity of the logic level low side gate control signal.

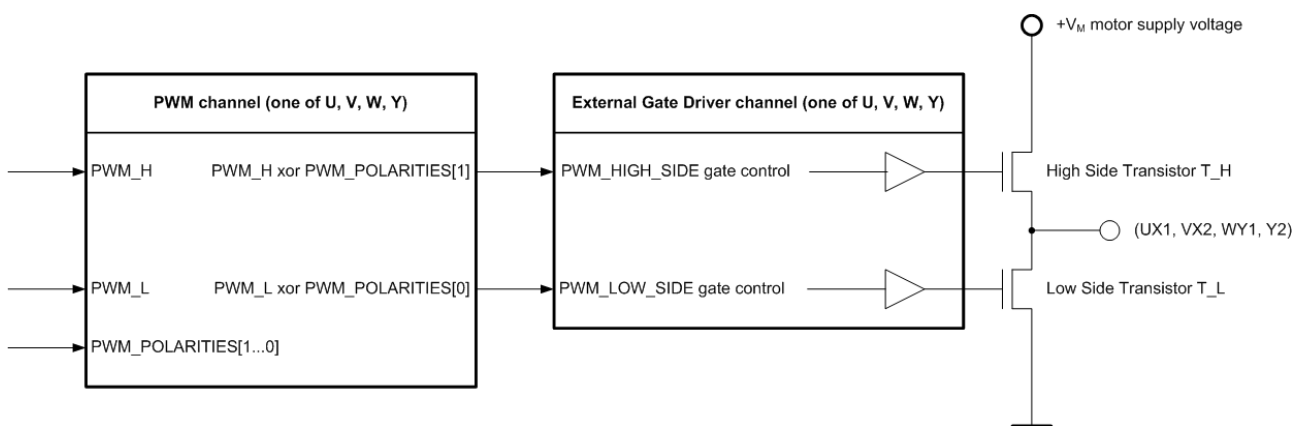

Figure 36: PWM Gate Driver Control Polarities

PWM_POLARITIES[1...0]	PWM_HIGH_SIDE	PWM_LOW_SIDE
0 0	PWM_H	PWM_L
0 1	PWM_H	not PWM_L
1 0	not PWM_H	PWM_L
1 1	not PWM_H	not PWM_L

Table 23: Status Flags Register



4.9.2 PWM Engine and associated Motor Connectors

The PWM engine of the TMC4671 has eight gate control outputs to control up to four power MOS half bridges. For three-phase motors three half bridges are used (U, V, W). For two-phase stepper motors four half bridges are used for (U, V, W, Y). For DC motor control, the first two half bridges (U, V) are used.

Gate Control Signals	FOC3: 3 Phase Motor	FOC2: 2 Phase Stepper	FOC1: Single Phase DC Motor
PWM_UX1_H PWM_UX1_L	U	X1	X1
PWM_VX2_H PWM_VX2_L	V	X2	X2
PWM_WY1_H PWM_WY1_L	W	Y1	-
PWM_Y2_H PWM_Y2_L	-	Y2	-

Table 24: FOC321 Gate Control Signal Configurations

For the DC motor current control (here named FOC1), the number of pole pairs is not relevant - in contrast to closed loop current control of two-phase stepper motors (FOC2) and three-phase permanent magnet motors (FOC3). For DC motor control, the number of pole pairs should be set to 1 to equal mechanical angle and electrical angle for velocity control and for position control.

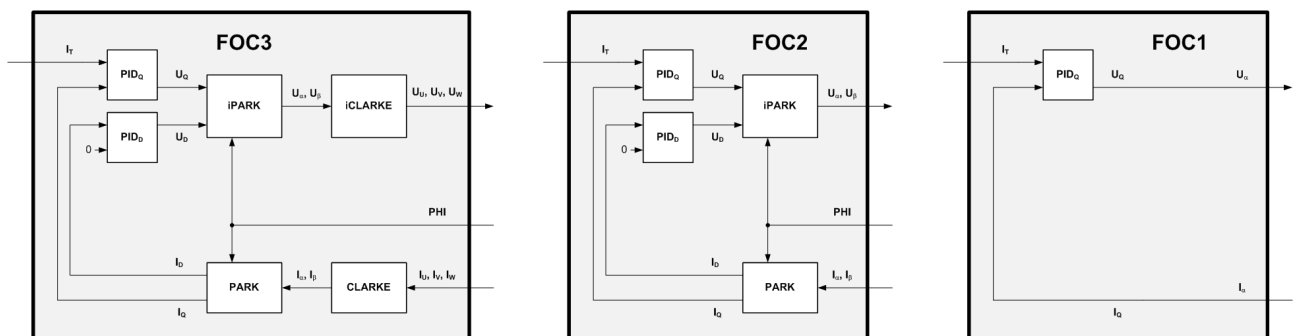

Figure 37: FOC3 (three phase motor), FOC2 (two phase stepper motor), FOC1 (single phase DC motor)



4.9.3 PWM Frequency

The PWM counter maximum length register PWM_MAXCNT controls the PWM frequency. For a clock frequency $f_{CLK} = 25 \text{ MHz}$, the PWM frequency $f_{PWM}[\text{Hz}] = (4.0 \cdot f_{CLK}[\text{Hz}]) / (\text{PWM_MAXCNT} + 1)$. With $f_{CLK} = 25 \text{ MHz}$ and power-on reset (POR) default of PWM_MAXCNT=3999, the PWM frequency $f_{PWM} = 25 \text{ kHz}$.

Note

The PWM frequency is the fundamental frequency of the control system. It can be changed at any time, also during motion for the classic PI controller structure. The advanced PI controller structure is tied to the PWM frequency and integrator gains have to be changed. Please make sure to set current measurement decimation rates to fit PWM period in high performance applications.

4.9.4 PWM Resolution

The base resolution of the PWM is 12 bit internally mapped to 16 bit range. The minimal PWM increment is 20ns due to the symmetrical PWM with 100 MHz counter frequency. MAX_PWMCNT = 4095 gives the full resolution of 12 bit with $\approx 25 \text{ kHz}$ w/ $f_{CLK}=25 \text{ MHz}$. MAX_PWMCNT=2047 results in 11 bit resolution, but with $\approx 50\text{kHz}$ w/ $f_{CLK}=25 \text{ MHz}$. So the PWM_MAXCNT defines the PWM frequency, but also affects the resolution of the PWM.

4.9.5 PWM Modes

The power-on reset (POR) default of the PWM is OFF. The standard PWM scheme is the centered PWM. Passive braking and freewheeling modes are available on demand. Please refer to section 7 concerning the settings.

4.9.6 Break-Before-Make (BBM)

One register controls BBM time for the high side, another register controls BBM time for the low side. The BBM times are programmable in 10 ns steps. The BBM time can be set to zero for gate drivers that have their own integrated BBM timers.

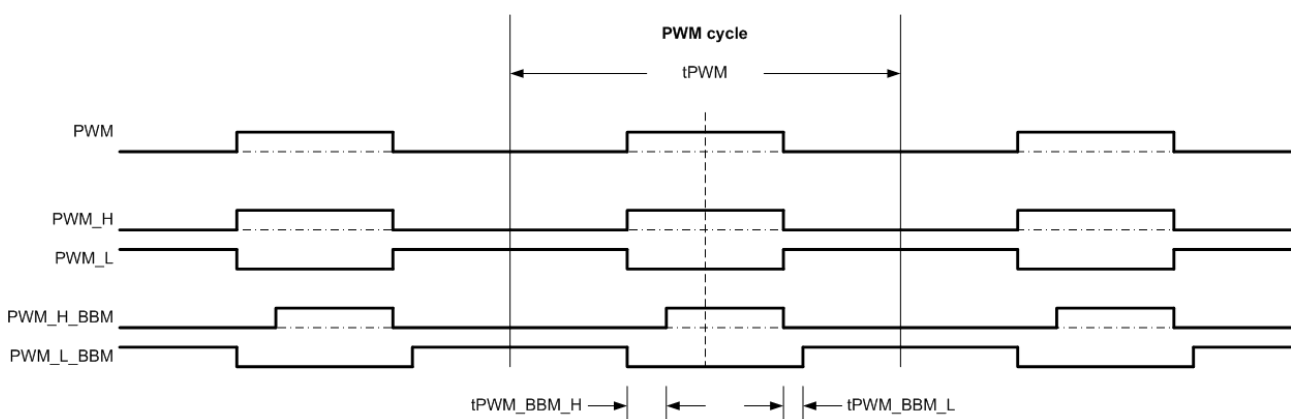

Figure 38: BBM Timing



Info

Measured BBM times at MOS-FET gates differ from programmed BBM times due to driver delays and possible additional gate driver BBM times. The programmed BBM times are for the digital control signals.

Note

Too short BBM times cause electrical shortcuts of the MOS-FET bridges - so called shoot through - that short the power supply and might damage the power stage and the power supply.

4.9.7 Space Vector PWM (SVPWM)

A single bit enables the Space Vector PWM (SVPWM). No further settings are required for the space vector PWM - just ON or OFF. The power on default for the SVPWM is OFF. Space Vector PWM can be enabled to maximize voltage utilization in the case of an isolated star point of the motor. If the star point is not isolated, SVPWM might cause unintended current flows through the star point. Space Vector PWM is only used for three-phase motors. For other motors the SVPWM must be switched off.

Note

For engineering samples TMC4671-ES, the Space Vector PWM does not allow higher voltage utilization. This is fixed for the release version TMC4671-LA.

4.9.8 Real- and Integer-Conversions

The TMC4671 displays voltages and currents as integer values. The following tables show how one can convert integer values to real values, see table 25, and the other way round, see table 26. Equation 2 in section 4.5.0.1 describes the chain of gains and introduces ADC_GAIN. This variable depends on resistance of the shuntresistor as well as the properties of the senseamplifier. It is needed for the current conversions. The voltage conversion depends on the supply voltage V_M .

Senseamps and their respective shunt resistors can deviate in their properties due to part tolerances or aging. However, their values must still be comparable. This is done by using a scaling factor for both ADCs in order to harmonize their signals.

$$\text{ADC_GAIN}_{\text{scaled}} = \left(\text{ADC_GAIN} \cdot \frac{\text{ADC_SCALE}}{256} \right) \quad (46)$$

	integer to real
$I_{uvw,\text{real}}$	$\frac{I_{uvw,s16}}{\text{ADC_GAIN}_{\text{scaled}}}$
$I_{\alpha\beta,\text{real}}$	$\frac{I_{\alpha\beta,s16}}{\text{ADC_GAIN}_{\text{scaled}}}$
$I_{dq,\text{real}}$	$\frac{I_{dq,s16}}{\text{ADC_GAIN}_{\text{scaled}}}$
$U_{dq,\text{real}}$	$U_{dq,s16} \cdot \frac{V_M}{2^{15}}$
$U_{\alpha\beta,\text{real}}$	$U_{\alpha\beta,s16} \cdot \frac{V_M}{2^{15}}$
$\text{FOC}_{uvw,\text{real}}$	$\text{FOC}_{uvw,s16} \cdot \frac{V_M}{2^{15}}$
$\text{PWM}_{uvw,\text{real}}$	$\text{PWM}_{uvw,s16} \cdot \frac{V_M}{2^{15}}$

Table 25: Factors for integer to real conversion



	real to integer
$I_{uvw,s16}$	$I_{uvw,real} \cdot ADC_GAIN_{scaled}$
$I_{\alpha\beta,s16}$	$I_{\alpha\beta,real} \cdot ADC_GAIN_{scaled}$
$I_{dq,s16}$	$I_{dq,real} \cdot ADC_GAIN_{scaled}$
$U_{dq,s16}$	$U_{dq,real} \cdot \frac{2^{15}}{\sqrt{V_M}}$
$U_{\alpha\beta,s16}$	$U_{\alpha\beta,real} \cdot \frac{2^{15}}{\sqrt{V_M}}$
$FOC_{uvw,s16}$	$FOC_{uvw,real} \cdot \frac{2^{15}}{\sqrt{V_M}}$
$PWM_{uvw,s16}$	$PWM_{dq,real} \cdot \frac{2^{15}}{\sqrt{V_M}}$

Table 26: Factors for real to integer conversion

The PWM value defines the outputvoltage. It is calculated using the content of register INTERIM_DATA while INTERIM_ADDR is 0x11 or 0x12. The s16 PWM value is converted to an u16 value by adding 0x8000. Equation 47 applies for the highside PWM when connected to a DC- or Stepper-motor as well as the three phases of a BLDC-motor when spacevector pwm is inactive:

$$U_{clamp} = (PWM_{uvw,s16} + 0x8000) \cdot \frac{V_M}{2^{16}} \quad (47)$$

Equation 48 describes the outputvoltage on the clamps for the lowside PWM when connected to a DC- or Stepper-motor:

$$U_{clamp} = (-PWM_{uxwy,s16} + 0x8000) \cdot \frac{V_M}{2^{16}} \quad (48)$$

The following equation describes the integer to real transformation for three-phase spacevector-PWM:

$$\begin{aligned} FOC_{MIN} &= \min(FOC_u, FOC_v, FOC_w) \\ FOC_{MAX} &= \max(FOC_u, FOC_v, FOC_w) \\ U_{clamp,uvw} &= \left(\frac{2}{\sqrt{3}} \cdot (PWM_{uvw,s16} - \frac{FOC_{MAX} + FOC_{MIN}}{2}) + 0x8000 \right) \cdot \frac{V_M}{2^{16}} \end{aligned} \quad (49)$$

5 Safety Functions

Different safety functions are integrated and mapped to status bits. A programmable mask register selects bits for activation of the STATUS output.

Internal hardware limiters for real time clipping and monitoring of interim values are available. LIMIT or LIMITS is part of register names of registers associated to internal limiters. Please refer to table 27.

Bit	Source
0	pid_x_target_limit
1	pid_x_target_ddt_limit
2	pid_x_errsum_limit
3	pid_x_output_limit
4	pid_v_target_limit
5	pid_v_target_ddt_limit



6	pid_v_errsum_limit
7	pid_v_output_limit
8	pid_id_target_limit
9	pid_id_target_ddt_limit
10	pid_id_errsum_limit
11	pid_id_output_limit
12	pid_iq_target_limit
13	pid_iq_target_ddt_limit
14	pid_iq_errsum_limit
15	pid_iq_output_limit
16	ipark_cirlim_limit_u_d
17	ipark_cirlim_limit_u_q
18	ipark_cirlim_limit_u_r
19	not_PLL_locked
20	ref_sw_r
21	ref_sw_h
22	ref_sw_l
23	---
24	pwm_min
25	pwm_max
26	adc_i_clipped
27	adc_aenc_clipped
28	ENC_N
29	ENC2_N
30	AENC_N
31	reserved

Table 27: Status Flags Register

All controllers have input limiters as offsets can be added to target values and they can be limited to remain in certain ranges. Also all controller outputs can be limited and the integrating parts (error sum) of the PI controllers are also limited to controller outputs. If d/dt-limiters are enabled they are also capable of limiting target values.

If one of these limiters gets active, the flag will go to high state. This is usually a normal operation, when controllers are working on the borders of their working area. With STATUS_MASK register corresponding flags can be activated.

Other status flags go to high state whether the voltage limitation is reached (circular limiter in iPark transformation) or PWM is saturated (pwm_min and pwm_max). This is also usual operation as the current controller has to deal with voltage limitation at high velocity operation.



The user can also use the status output to generate an IRQ on reference switch or N-channel of encoder. Also ADC clipping can be monitored which is a good indicator of wrong or faulty behavior. Remaining `wd_error` status flag indicates an error on the clock input of the TMC4671 (see following section).
Status flags register can be written directly. It is not possible to clear individual bits.



6 FOC Setup - How to Turn a Motor

This section summarizes the basic steps that are required to turn a motor with TMC4671. The wizard of the TMCL-IDE guides the user through these basic steps. Schematics and Layout of the TMC4671 evaluation kit are open source and available for download from www.trinamic.com

Note TRINAMIC recommends to use a TMC4671 evaluation kit together with the TMCL-IDE with its integrated wizards for initial evaluation and setup.

In order to create own application software please check [TRINAMIC's API](#) to reduce software development efforts.

6.1 Select Motor Type

The TMC4671 supports closed loop control of single phase DC motors, stepper motors, and three phase motors. The selection of the motor type defines the configuration of the gate control channels for the power stage and either the usage or bypass of FOC transformations (Clarke, Park, iPark, iClark).

6.1.1 FOC1 Setup - How to Turn a Single Phase DC Motor

In case of DC motor, the mechanical commutator of the DC motor realizes something like mechanical field oriented control where the TMC4671 just realizes closed loop current control of the DC motor. From FOC point of view, the FOC converts a brushless motor (BLDC) resp. Permanent Magnet Synchronous Motor (PMSM) into a closed loop current controlled DC motor.

From closed loop velocity control point of view and from closed loop position control point of view there is no difference between electronically FOC controlled BLDC motor or PMSM motor and a mechanical commutated DC motor with electronic closed loop current control.

6.1.2 FOC2 Setup - How to Turn a Two Phase Motor (Stepper)

The TMC4671 is able to turn a two-phase stepper motor with FOC by internal skip of Clarke transformation and iClarke transformation. A special feature of stepper motors is the high number of pole pairs (NPP) that are typical 50. For stepper motors it is usual to give the number of full steps (FS) per revolution, with $NPP = (FS/revolution) / 4$. A stepper with 200 full steps per revolution has 50 pole pairs.

6.1.3 FOC3 Setup - How to Turn a Three Phase Motor (PMSM or BLDC)

A three phase motor is the classical FOC controlled brushless motor. Users have to take care concerning number of pole pairs (NPP) and the number of poles (NP) with $NPP = NP/2$.

6.2 Set Number of Pole Pairs (NPP)

The number of (magnetic) pole pairs (NPP) is characteristic for each motor and it is essential for commutation of two phase motors and three phase motors with FOC. For DC motor the NPP is not important for commutation itself, but it should be set to one to have same scaling for electrical angle and mechanical angle.



6.3 Run Motor Open Loop

Initial turning a motor open loop is useful for determination of the association between phase voltage, phase currents and for position sensor setup. Position sensors that are mounted on a motor might have an opposite direction of rotation compared to the motor. The same direction of rotation is essential for the FOC. In addition, the phase shift between rotor angle and angle that is measured by a position sensor needs to be zero in best case. Otherwise the motor is operated at lower efficiency or turns in wrong direction which causes instability.

6.3.1 Determination of Association between Phase Voltage and Phase Currents

For starters, the motor should be turned open loop to measure ADC offsets and set ADC scaler offset. Additionally, the open loop turn is useful to validate (or to determine) the association between motor phase currents and motor phase terminal voltages. This association is essential for the FOC. With proper ADC channel selection setup, voltage U_UX1 is in phase with current I_UX1, voltage U_VX2 is in phase with current I_VX2, and voltage U_WY1 is in phase with I_WY1. For two phase stepper motor, the voltage U_Y2 is in phase with current I_Y2. Only two currents are measured and the other current is calculated by TMC4671. For DC motor only one current is measured.

6.3.2 Determination of Direction of Rotation and Phase Shift of Angles

For absolute position sensors like Hall sensors, the phase shift and the direction of rotation only need to be determined once initially. For relative position sensors, like incremental encoders, the direction of turning needs to be determined everytime after power cycle. The relative orientation between measured incremental encoder angle and rotor angle needs to be determined on each power-up.

6.4 Selection of Position Sensors

For closed loop operation, the type of encoder (digital hall, ABN encoder, analog Hall, SinCos) needs to be set. For analog Hall signals or analog incremental encoders the user needs to adjust the analog ADC channels for the analog encoders - similar to ADC offset and ADC scaling as for current measuring ADC channels. The TMC4671 allows the selection of different types of position sensors for different tasks. One position sensor is for the inner FOC closed loop current control loop.

6.4.1 Selection of FOC sensor for PHI_E

One sensor needs to be selected for the FOC to measure the electrical angle PHI_E. This sensor is used for the inner closed loop control loop for closed loop current control.

6.4.2 Selection of sensor for VELOCITY

One sensor needs to be selected for measurement of velocity. This can be the sensor selected for measurement of PHI_E but it is more common to use the mechanical angle PHI_M for measurement of velocity. Using electrical angles can give advantages for applications with slow motion for NPP more than one because the minimum velocity in RPM [revolutions per minute] is one and the electrical angles have higher speed than mechanical angles.

6.4.3 Selection of sensor for POSITION

One sensor needs to be selected for measurement of position of the rotor, the angle of the rotor. This can be the sensor selected for measurement PHI_E but it is more usual to use the mechanical angle PHI_M for measurement of position. For stepper motors it might make sense to select the electrical angle PHI_E for



positioning to have a benefit from higher resolution using electrical angles. This is because each period - electrical or mechanical - is normalized to $2^{16} = 65536$ positions.

6.5 Modes of Operation - (Open Loop), Torque, Velocity, Positioning

The TMC4671 can operate in torque mode, velocity mode, or position mode. The control loops (current, velocity, position) are cascaded, thus the outer loops depend on the tuning of the inner loops. So, the current loop must be adjusted first. The velocity loop must be adjusted after the current control loop is adjusted. The position control loop must be adjusted last.

6.6 Controller Tuning

PI controller tuning is described throughout the control theory literature. In general there are two main strategies to tune the controllers. First strategy is to observe controller step response for different parameter sets and tune parameters to fit dynamics and settling time. With this approach sampling target and actual value as well as controller output (check for saturation) at fixed frequency is recommended. The USB-2-RTMI adapter in combination with the TMCL-IDE provide tuning tools to support this strategy. Another approach is to identify controller plant parameters and calculate controller parameters from these parameters. This is also supported by the TMCL-IDE for the current control loop. For the other control loops the first strategy is recommended.

7 Register Map

The TMC4671 has an register address range of 128 addresses with registers up to 32 bit data width. Some registers hold 32 bit data fields, some hold 2 x 16 bit data fields and other hold combinations of different data fields with individual data types. Data fields need to be extracted by masking and shifting after read from a TMC4671 register within the application. Data fields need to be composed by masking and shifting by the application before writing into a TMC4671 register. Please check [TRINAMIC's API](#) to reduce software development efforts. This section describes the register bank of the TMC4671.

Section [7.1](#) gives an overview over all registers. It is intended to give an initial overview of all registers.

Section [7.2](#) is the detailed reference of all registers and the register fields.

Section [7.3](#) gives the description of power-on-reset default values of all registers.



7.1 Register Map - Overview

Registers in TMC4671 have different purposes. Some registers are used for test only, other can be used to monitor internal states (e.g. ADC values). Most registers are only accessed during initialisation (e.g. calibration or control parameters). Control registers are used for input of target values to controllers and should be updated regularly according to chosen motion modes (e.g. PID_VELOCITY_TARGET should be updated in velocity mode). If users don't use a certain functional block they don't need to parametrize it.

The TMC4671 has an address space of 128 addresses. In order to display more than 128 registers, so called stacked registers were added. These are CHIPINFO_DATA, ADC_RAW_DATA, PID_ERROR_DATA, CONFIG_DATA and INTERIM_DATA. These data registers display or give access to different subregisters according to their corresponding address registers (CHIPINFO_ADDR, ADC_RAW_ADDR, PID_ERROR_ADDR, CONFIG_ADDR and INTERIM_ADDR). Read access to a subregister requires a write access to address register and a read access to the data register.

Address	Registername	Access	Usage
0x00 _h	CHIPINFO_DATA	R	Test
0x01 _h	CHIPINFO_ADDR	RW	Test
0x02 _h	ADC_RAW_DATA	R	Monitor
0x03 _h	ADC_RAW_ADDR	RW	Monitor
0x04 _h	dsADC_MCFG_B_MCFG_A	RW	Init
0x05 _h	dsADC_MCLK_A	RW	Init
0x06 _h	dsADC_MCLK_B	RW	Init
0x07 _h	dsADC_MDEC_B_MDEC_A	RW	Init
0x08 _h	ADC_I1_SCALE_OFFSET	RW	Init
0x09 _h	ADC_I0_SCALE_OFFSET	RW	Init
0x0A _h	ADC_I_SELECT	RW	Init
0x0B _h	ADC_I1_I0_EXT	RW	Test
0x0C _h	DS_ANALOG_INPUT_STAGE_CFG	RW	Test
0x0D _h	AENC_0_SCALE_OFFSET	RW	Init
0x0E _h	AENC_1_SCALE_OFFSET	RW	Init
0x0F _h	AENC_2_SCALE_OFFSET	RW	Init
0x11 _h	AENC_SELECT	RW	Init
0x12 _h	ADC_IWY_IUX	R	Monitor
0x13 _h	ADC_IV	R	Monitor
0x15 _h	AENC_WY_UX	R	Monitor
0x16 _h	AENC_VN	R	Monitor
0x17 _h	PWM_POLARITIES	RW	Init
0x18 _h	PWM_MAXCNT	RW	Init
0x19 _h	PWM_BBM_H_BBM_L	RW	Init
0x1A _h	PWM_SV_CHOP	RW	Init



Address	Registername	Access	Usage
0x1B _h	MOTOR_TYPE_N_POLE_PAIRS	RW	Init
0x1C _h	PHI_E_EXT	RW	Test
0x1F _h	OPENLOOP_MODE	RW	Init
0x20 _h	OPENLOOP_ACCELERATION	RW	Init
0x21 _h	OPENLOOP_VELOCITY_TARGET	RW	Init
0x22 _h	OPENLOOP_VELOCITY_ACTUAL	RW	Monitor
0x23 _h	OPENLOOP_PHI	RW	Monitor/Test
0x24 _h	UQ_UD_EXT	RW	Init/Test
0x25 _h	ABN_DECODER_MODE	RW	Init
0x26 _h	ABN_DECODER_PPR	RW	Init
0x27 _h	ABN_DECODER_COUNT	RW	Init/Test/Monitor
0x28 _h	ABN_DECODER_COUNT_N	RW	Init/Test/Monitor
0x29 _h	ABN_DECODER_PHI_E_PHI_M_OFFSET	RW	Init
0x2A _h	ABN_DECODER_PHI_E_PHI_M	R	Monitor
0x2C _h	ABN_2_DECODER_MODE	RW	Init
0x2D _h	ABN_2_DECODER_PPR	RW	Init
0x2E _h	ABN_2_DECODER_COUNT	RW	Init/Test/Monitor
0x2F _h	ABN_2_DECODER_COUNT_N	RW	Init/Test/Monitor
0x30 _h	ABN_2_DECODER_PHI_M_OFFSET	RW	Init
0x31 _h	ABN_2_DECODER_PHI_M	R	Monitor
0x33 _h	HALL_MODE	RW	Init
0x34 _h	HALL_POSITION_060_000	RW	Init
0x35 _h	HALL_POSITION_180_120	RW	Init
0x36 _h	HALL_POSITION_300_240	RW	Init
0x37 _h	HALL_PHI_E_PHI_M_OFFSET	RW	Init
0x38 _h	HALL_DPHI_MAX	RW	Init
0x39 _h	HALL_PHI_E_INTERPOLATED_PHI_E	R	Monitor
0x3A _h	HALL_PHI_M	R	Monitor
0x3B _h	AENC_DECODER_MODE	RW	Init
0x3C _h	AENC_DECODER_N_THRESHOLD	RW	Init
0x3D _h	AENC_DECODER_PHI_A_RAW	R	Monitor
0x3E _h	AENC_DECODER_PHI_A_OFFSET	RW	Init
0x3F _h	AENC_DECODER_PHI_A	R	Monitor
0x40 _h	AENC_DECODER_PPR	RW	Init



Address	Registername	Access	Usage
0x41 _h	AENC_DECODER_COUNT	R	Monitor
0x42 _h	AENC_DECODER_COUNT_N	RW	Monitor/Init
0x45 _h	AENC_DECODER_PHI_E_PHI_M_OFFSET	RW	Init
0x46 _h	AENC_DECODER_PHI_E_PHI_M	R	Monitor
0x4B _h	PIDIN_VELOCITY_TARGET	R	Monitor
0x4C _h	PIDIN_POSITION_TARGET	R	Monitor
0x4D _h	CONFIG_DATA	RW	Init
0x4E _h	CONFIG_ADDR	RW	Init
0x50 _h	VELOCITY_SELECTION	RW	Init
0x51 _h	POSITION_SELECTION	RW	Init
0x52 _h	PHI_E_SELECTION	RW	Init
0x53 _h	PHI_E	R	Monitor
0x54 _h	PID_FLUX_P_FLUX_I	RW	Init
0x56 _h	PID_TORQUE_P_TORQUE_I	RW	Init
0x58 _h	PID_VELOCITY_P_VELOCITY_I	RW	Init
0x5A _h	PID_POSITION_P_POSITION_I	RW	Init
0x5D _h	PIDOUT_UQ_UD_LIMITS	RW	Init
0x5E _h	PID_TORQUE_FLUX_LIMITS	RW	Init
0x60 _h	PID_VELOCITY_LIMIT	RW	Init
0x61 _h	PID_POSITION_LIMIT_LOW	RW	Init
0x62 _h	PID_POSITION_LIMIT_HIGH	RW	Init
0x63 _h	MODE_RAMP_MODE_MOTION	RW	Init
0x64 _h	PID_TORQUE_FLUX_TARGET	RW	Control
0x65 _h	PID_TORQUE_FLUX_OFFSET	RW	Control
0x66 _h	PID_VELOCITY_TARGET	RW	Control
0x67 _h	PID_VELOCITY_OFFSET	RW	Control
0x68 _h	PID_POSITION_TARGET	RW	Control
0x69 _h	PID_TORQUE_FLUX_ACTUAL	R	Monitor
0x6A _h	PID_VELOCITY_ACTUAL	R	Monitor
0x6B _h	PID_POSITION_ACTUAL	RW	Monitor/Init
0x6C _h	PID_ERROR_DATA	R	Test
0x6D _h	PID_ERROR_ADDR	RW	Test
0x6E _h	INTERIM_DATA	RW	Monitor
0x6F _h	INTERIM_ADDR	RW	Monitor



Address	Registername	Access	Usage
0x75 _h	ADC_VM_LIMITS	RW	Init
0x76 _h	TMC4671_INPUTS_RAW	R	Test/Monitor
0x77 _h	TMC4671_OUTPUTS_RAW	R	Test/Monitor
0x78 _h	STEP_WIDTH	RW	Init
0x79 _h	UART_BPS	RW	Init
0x7B _h	GPIO_dsADCI_CONFIG	RW	Init
0x7C _h	STATUS_FLAGS	RW	Monitor
0x7D _h	STATUS_MASK	RW	Monitor

Table 28: TMC4671 Registers



7.2 Register Map - Functional Description

ADDR	NAME	DATA TYPE (BIT MASK)	FUNCTION
0x00 _h	CHIPINFO_DATA		This register displays name and version information of the accessed IC. It can be used for test of communication.
	SI_TYPE	u32(31:0)	0: Hardware type (ASCII).
	SI_VERSION	u32(31:0)	0: Hardware version (u16.u16).
	SI_DATE	u32(31:0)	0: Hardware date (nibble wise date stamp yyyyymmdd).
	SI_TIME	u32(31:0)	0: Hardware time (nibble wise time stamp -hhmmss)
	SI_VARIANT	u32(31:0)	
	SI_BUILD	u32(31:0)	
0x01 _h	CHIPINFO_ADDR		This register is used to change displayed information in register CHIPINFO_DATA.
	CHIP_INFO_ADDRESS	u8(7:0)	0: SI_TYPE 1: SI_VERSION 2: SI_DATE 3: SI_TIME 4: SI_VARIANT 5: SI_BUILD
0x02 _h	ADC_RAW_DATA		This registers displays ADC values. Th displayed registers can be switched by register ADC_RAW_ADDR.
	ADC_I0_RAW	u16(15:0)	Raw phase current I0
	ADC_I1_RAW	u16(31:16)	Raw phase current I1
	ADC_VM_RAW	u16(15:0)	Raw supply voltage value.
	ADC_AGPI_A_RAW	u16(31:16)	Raw analog gpi A value.
	ADC_AGPI_B_RAW	u16(15:0)	Raw analog gpi B value.
	ADC_AENC_UX_RAW	u16(31:16)	Raw analog encoder signal.
	ADC_AENC_VN_RAW	u16(15:0)	Raw analog encoder signal.
	ADC_AENC_WY_RAW	u16(31:16)	Raw analog encoder signal.
0x03 _h	ADC_RAW_ADDR		This register is used to change displayed information in register ADC_RAW_DATA.



	ADC_RAW_ADDR	u8(7:0)	0: ADC_I1_RAW & ADC_I0_RAW 1: ADC_AGPI_A_RAW & ADC_VM_RAW 2: ADC_AENC_UX_RAW & ADC_AGPI_B_RAW 3: ADC_AENC_WY_RAW & ADC_AENC_VN_RAW
0x04 _h	dsADC_MCFG_B_MCFG_A		This register is used to configure internal ADCs (delta sigma modulators). Don't modify if you want to use internal Delta Sigma modulators (Standard use case).
	cfg_dsmodulator_a	u2(1:0)	0: int. dsMOD 1: ext. MCLK input 2: ext. MCLK output 3: ext. CMP
	mclk_polarity_a	bit(2)	0: off 1: on
	mdat_polarity_a	bit(3)	0: off 1: on
	sel_nclk_mclk_i_a	bit(4)	0: off 1: on
	blanking_a	u8(15:8)	
	cfg_dsmodulator_b	u2(17:16)	0: int. dsMOD 1: ext. MCLK input 2: ext. MCLK output 3: ext. CMP
	mclk_polarity_b	bit(18)	0: off 1: on
	mdat_polarity_b	bit(19)	0: off 1: on
	sel_nclk_mclk_i_b	bit(20)	0: off 1: on
	blanking_b	u8(31:24)	
0x05 _h	dsADC_MCLK_A		This register is used to modify Delta Sigma modulator clock. Do not modify if you use internal delta sigma modulators (Standard use case).



	dsADC_MCLK_A	u32(31:0)	$fMCLK_A = 2^{31} / (fCLK * (dsADC_MCLK_A + 1))$, $dsADC_MCLK_A = (2^{31} / (fMCLK * fCLK)) - 1$
0x06 _h	dsADC_MCLK_B		This register is used to modify Delta Sigma modulator clock. Do not modify if you use internal delta sigma modulators (Standard use case).
	dsADC_MCLK_B	u32(31:0)	$fMCLK_B = 2^{31} / (fCLK * (dsADC_MCLK_B + 1))$, $dsADC_MCLK_B = (2^{31} / (fMCLK * fCLK)) - 1$
0x07 _h	dsADC_MDEC_B_MDEC_A		This register is used to change decimation rates of SINC3 filters for Delta Sigma modulators. Set values according to actual PWM frequency. See functional description of ADC engine.
	dsADC_MDEC_A	u16(15:0)	0: PWM synchronous, others according to register content
	dsADC_MDEC_B	u16(31:16)	0: PWM synchronous, others according to register content
0x08 _h	ADC_I1_SCALE_OFFSET		This register is used to set calibration data for ADC channel I1 (Offset and amplitude correction).
	ADC_I1_OFFSET	u16(15:0)	Offset for current ADC channel 1.
	ADC_I1_SCALE	s16(31:16)	Scaling factor for current ADC channel 1.
0x09 _h	ADC_I0_SCALE_OFFSET		This register is used to set calibration data for ADC channel I0 (Offset and amplitude correction).
	ADC_I0_OFFSET	u16(15:0)	Offset for current ADC channel 0.
	ADC_I0_SCALE	s16(31:16)	Scaling factor for current ADC channel 0.
0x0A _h	ADC_I_SELECT		This register is used to assign correct ADC channel to PWM output channel. For each FOC input current either an ADC value or the calculated sum of the currents (I2) can be assigned to match internal data processing to power stage design.
	ADC_I0_SELECT	u8(7:0)	Select input for raw current ADC_I0_RAW. 0: ADCSD_I0_RAW (sigma delta ADC)



	ADC_I1_SELECT	u8(15:8)	<p>1: ADCSD_I1_RAW (sigma delta ADC)</p> <p>2: ADC_I0_EXT (from register)</p> <p>3: ADC_I1_EXT (from register)</p> <p>Select input for raw current ADC_I1_RAW.</p> <p>0: ADCSD_I0_RAW (sigma delta ADC)</p> <p>1: ADCSD_I1_RAW (sigma delta ADC)</p> <p>2: ADC_I0_EXT (from register)</p> <p>3: ADC_I1_EXT (from register)</p>
	ADC_I_UX_SELECT	u2(25:24)	<p>0: UX = ADC_I0 (default)</p> <p>1: UX = ADC_I1</p> <p>2: UX = ADC_I2</p>
	ADC_I_V_SELECT	u2(27:26)	<p>0: V = ADC_I0</p> <p>1: V = ADC_I1 (default)</p> <p>2: V = ADC_I2</p>
	ADC_I_WY_SELECT	u2(29:28)	<p>0: WY = ADC_I0</p> <p>1: WY = ADC_I1</p> <p>2: WY = ADC_I2 (default)</p>
0x0B _h	ADC_I1_I0_EXT		This register can be used to write ADC values via SPI in case external ADCs are used or controller cascade function shall be tested. using external ADCs will probably effect control performance is not recommended.
	ADC_I0_EXT	u16(15:0)	Register for write of ADC_I0 value from external source (eg. CPU).
	ADC_I1_EXT	u16(31:16)	Register for write of ADC_I1 value from external source (eg. CPU).
0x0C _h	DS_ANALOG_INPUT_STAGE_CFG		This register is used to configure ADC channels for different input configurations and test modes.
	ADC_I0	u4(3:0)	<p>0: INP vs. INN</p> <p>1: GND vs. INN</p> <p>2: VDD/4</p> <p>3: 3*VDD/4</p> <p>4: INP vs. GND</p> <p>5: VDD/2</p>



ADC_I1	u4(7:4)	6: VDD/4 7: 3*VDD/4 0: INP vs. INN 1: GND vs. INN 2: VDD/4 3: 3*VDD/4 4: INP vs. GND 5: VDD/2 6: VDD/4 7: 3*VDD/4
ADC_VM	u4(11:8)	0: INP vs. INN 1: GND vs. INN 2: VDD/4 3: 3*VDD/4 4: INP vs. GND 5: VDD/2 6: VDD/4 7: 3*VDD/4
ADC_AGPI_A	u4(15:12)	0: INP vs. INN 1: GND vs. INN 2: VDD/4 3: 3*VDD/4 4: INP vs. GND 5: VDD/2 6: VDD/4 7: 3*VDD/4
ADC_AGPI_B	u4(19:16)	0: INP vs. INN 1: GND vs. INN 2: VDD/4 3: 3*VDD/4 4: INP vs. GND 5: VDD/2 6: VDD/4 7: 3*VDD/4
ADC_AENC_UX	u4(23:20)	0: INP vs. INN 1: GND vs. INN



	ADC_AENC_VN	u4(27:24)	2: VDD/4 3: 3*VDD/4 4: INP vs. GND 5: VDD/2 6: VDD/4 7: 3*VDD/4 0: INP vs. INN 1: GND vs. INN 2: VDD/4 3: 3*VDD/4 4: INP vs. GND 5: VDD/2 6: VDD/4 7: 3*VDD/4
	ADC_AENC_WY	u4(31:28)	0: INP vs. INN 1: GND vs. INN 2: VDD/4 3: 3*VDD/4 4: INP vs. GND 5: VDD/2 6: VDD/4 7: 3*VDD/4
0x0D _h	AENC_0_SCALE_OFFSET		This register is used to set calibration data for ADC channel AENC 0 (Offset and amplitude correction).
	AENC_0_OFFSET	u16(15:0)	Offset for Analog Encoder ADC channel 0.
	AENC_0_SCALE	s16(31:16)	Scaling factor for Analog Encoder ADC channel 0.
0x0E _h	AENC_1_SCALE_OFFSET		This register is used to set calibration data for ADC channel AENC 1 (Offset and amplitude correction).
	AENC_1_OFFSET	u16(15:0)	Offset for Analog Encoder ADC channel 1.
	AENC_1_SCALE	s16(31:16)	Scaling factor for Analog Encoder ADC channel 1.
0x0F _h	AENC_2_SCALE_OFFSET		This register is used to set calibration data for ADC channel AENC 2 (Offset and amplitude correction).



	AENC_2_OFFSET	u16(15:0)	Offset for Analog Encoder ADC channel 2.
	AENC_2_SCALE	s16(31:16)	Scaling factor for Analog Encoder ADC channel 2.
0x11 _h	AENC_SELECT		This register is used to select correct ADC to compensate wiring twists.
	AENC_0_SELECT	u8(7:0)	Select analog encoder ADC channel for raw analog encoder signal AENC_0_RAW. 0: <AENC_UX_RAW> 1: AENC_VN_RAW 2: AENC_WY_RAW
	AENC_1_SELECT	u8(15:8)	Select analog encoder ADC channel for raw analog encoder signal AENC_1_RAW. 0: AENC_UX_RAW 1: <AENC_VN_RAW> 2: AENC_WY_RAW
	AENC_2_SELECT	u8(23:16)	Select analog encoder ADC channel for raw analog encoder signal AENC_2_RAW. 0: AENC_UX_RAW 1: AENC_VN_RAW 2: <AENC_WY_RAW>
0x12 _h	ADC_IWY_IUX		This register can be used to monitor phase current values (offset-compensated, scaled and correctly assigned).
	ADC_IUX	s16(15:0)	Register of scaled current ADC value including signed added offset as input for the FOC.
	ADC_IWY	s16(31:16)	Register of scaled current ADC value including signed added offset as input for the FOC.
0x13 _h	ADC_IV		This register can be used to monitor phase current ADC_IV (offset-compensated, scaled and correctly assigned).
	ADC_IV	s16(15:0)	Register of scaled current ADC value including signed added offset as input for the FOC.



0x15 _h	AENC_WY_UX		This register displays AENC input signals (offset-compensated, scaled and correctly assigned).
	AENC_UX	s16(15:0)	Register of scaled analog encoder value including signed added offset as input for the interpolator.
	AENC_WY	s16(31:16)	Register of scaled analog encoder value including signed added offset as input for the interpolator.
0x16 _h	AENC_VN		This register displays AENC input signal AENC_VN (offset-compensated, scaled and correctly assigned).
	AENC_VN	s16(15:0)	Register of scaled analog encoder value including signed added offset as input for the interpolator.
0x17 _h	PWM_POLARITIES		This register sets the polarity of PWM output signal to match gate driver.
	PWM_POLARITIES[0]	bit(0)	Low Side gate control 0: off 1: on
	PWM_POLARITIES[1]	bit(1)	High Side gate control 0: off 1: on
0x18 _h	PWM_MAXCNT		This register is used to configure PWM output frequency.
	PWM_MAXCNT	u12(11:0)	PWM maximum (count-1), PWM frequency is $f_{\text{PWM}}[\text{Hz}] = 100\text{MHz}/(\text{PWM_MAXCNT}+1)$
0x19 _h	PWM_BBM_H_BBM_L		This register sets the BBM times for PWM output signals. BBM time must be matched power stage needs to avoid cross conduction in half bridge.
	PWM_BBM_L	u8(7:0)	Break Before Make time $t_{\text{BBM_L}}[10\text{ns}]$ for low side MOS-FET gate control
	PWM_BBM_H	u8(15:8)	Break Before Make time $t_{\text{BBM_H}}[10\text{ns}]$ for high side MOS-FET gate control



0x1A _h	PWM_SV_CHOP		This register is used to enable PWM, set different PWM test modes and switch on the SVPWM feature for higher voltage utilization (BLDC/PMSM only).
	PWM_CHOP	u8(7:0)	PWM chopper mode, defining how to chopper 0: off, free running 1: off, low side permanent = ON 2: off, high side permanent = ON 3: off, free running 4: off, free running 5: low side chopper, high side off 6: high side chopper, low side off 7: centered PWM for FOC
	PWM_SV	bit(8)	use Space Vector PWM 0: Space Vector PWM disabled 1: Space Vector PWM enabled
0x1B _h	MOTOR_TYPE_N_POLE_PAIRS		This register is used to set motor type and number of pole pairs.
	N_POLE_PAIRS	u16(15:0)	Number n of pole pairs of the motor for calculation $\phi_e = \phi_m / N_POLE_PAIRS$.
	MOTOR_TYPE	u8(23:16)	0: No motor 1: Single phase DC 2: Two phase Stepper 3: Three phase BLDC
0x1C _h	PHI_E_EXT		This register is used to set an electrical angle for SW mode when encoder is connected to MCU and not to TMC4671.
	PHI_E_EXT	s16(15:0)	Electrical angle ϕ_{e_ext} for external writing into this register.
0x1F _h	OPENLOOP_MODE		This register is used to change direction of openloop angle.
	OPENLOOP_PHI_DIRECTION	bit(12)	Open loop phi direction. 0: positive 1: negative



0x20 _h	OPENLOOP_ACCELERATION		This register is used to change acceleration when openloop angle velocity should change.
	OPENLOOP_ACCELERATION	u32(31:0)	Acceleration of open loop phi.
0x21 _h	OPENLOOP_VELOCITY_TARGET		This register is used to set a target velocity for openloop angle generator. The velocity is ramped up and down according to OPENLOOP_ACCELERATION and PID_VELOCITY_LIMIT.
	OPENLOOP_VELOCITY_TARGET	s32(31:0)	Target velocity of open loop phi.
0x22 _h	OPENLOOP_VELOCITY_ACTUAL		This register displays actual openloop angle velocity in RPM.
	OPENLOOP_VELOCITY_ACTUAL	s32(31:0)	Actual velocity of open loop generator.
0x23 _h	OPENLOOP_PHI		This register displays actual output of openloop angle generator
	OPENLOOP_PHI	s16(15:0)	Angle phi open loop (either mapped to electrical angle phi _e or mechanical angle phi _m).
0x24 _h	UQ_UD_EXT		This register is used to set voltage values for openloop current control mode (UQ_UD_EXT_MODE).
	UD_EXT	s16(15:0)	External writable parameter for open loop voltage control mode, usefull during system setup, U_D component.
	UQ_EXT	s16(31:16)	External writable parameter for open loop voltage control mode, usefull during system setup, U_Q component.
0x25 _h	ABN_DECODER_MODE		This register is used to configure decoder input signals and N pulse action as well as count direction.
	apol	bit(0)	Polarity of A pulse. 0: off 1: on
	bpol	bit(1)	Polarity of B pulse. 0: off 1: on
	npol	bit(2)	Polarity of N pulse. 0: off 1: on



	use_abn_as_n	bit(3)	N and A and B 0: Ignore A and B polarity with Npulse = N 1: Npulse = N and A and B
	cln	bit(8)	Write direction at Npulse event between ABN_DECODER_COUNT_N and ABN_DECODER_COUNT. 0: COUNT => COUNT_N 1: COUNT_N => COUNT
	direction	bit(12)	Decoder count direction. 0: positive 1: negative
0x26 _h	ABN_DECODER_PPR		This register is used to set PPR number of encoder.
	ABN_DECODER_PPR	u24(23:0)	Decoder pulses per mechanical revolution.
0x27 _h	ABN_DECODER_COUNT		This register displays the actual count of encoder steps. It can be overwritten for initialization.
	ABN_DECODER_COUNT	u24(23:0)	Raw decoder count; the digital decoder engine counts modulo (decoder_ppr).
0x28 _h	ABN_DECODER_COUNT_N		This register displays the count value at last N pulse event. It can also be used to overwrite Decoder count at N pulse event according to decoder mode register setting.
	ABN_DECODER_COUNT_N	u24(23:0)	Decoder count latched on N pulse, when N pulse clears decoder_count also decoder_count_n is 0.
0x29 _h	ABN_DECODER_PHI_E_PHI_M_OFFSET		This register can be used to set offsets for electrical and mechanical angle calculated from decoder.
	ABN_DECODER_PHI_M_OFFSET	s16(15:0)	ABN_DECODER_PHI_M_OFFSET to shift (rotate) angle DECODER_PHI_M.
	ABN_DECODER_PHI_E_OFFSET	s16(31:16)	ABN_DECODER_PHI_E_OFFSET to shift (rotate) angle DECODER_PHI_E.
0x2A _h	ABN_DECODER_PHI_E_PHI_M		This register displays actual angle values for ABN encoder.



	ABN_DECODER_PHI_M	s16(15:0)	$ABN_DECODER_PHI_M = ABN_DECODER_COUNT * 2^{16} / ABN_DECODER_PPR + ABN_DECODER_PHI_M_OFFSET;$
	ABN_DECODER_PHI_E	s16(31:16)	$ABN_DECODER_PHI_E = (ABN_DECODER_PHI_M * N_POLE_PAIRS_) + ABN_DECODER_PHI_E_OFFSET$
0x2C _h	ABN_2_DECODER_MODE		This register is used to configure decoder input signals and N pulse action as well as count direction.
	apol	bit(0)	Polarity of A pulse. 0: off 1: on
	bpol	bit(1)	Polarity of B pulse. 0: off 1: on
	npol	bit(2)	Polarity of N pulse. 0: off 1: on
	use_abn_as_n	bit(3)	0: Ignore A and B polarity with Npulse = N, 1 : Npulse = N and A and B 0: Ignore A and B polarity with Npulse = N 1: Npulse = N and A and B
	cln	bit(8)	Write direction at Npulse event between ABN_2_DECODER_COUNT_N and ABN_2_DECODER_COUNT. 0: COUNT => COUNT_N 1: COUNT_N => COUNT
	direction	bit(12)	Decoder count direction. 0: positive 1: negative
0x2D _h	ABN_2_DECODER_PPR		This register is used to set PPR number of encoder.
	ABN_2_DECODER_PPR	u24(23:0)	Decoder_2 pulses per mechanical revolution. This 2nd ABN encoder interface is for positioning or velocity control but NOT for motor commutation.



0x2E _h	ABN_2_DECODER_COUNT ABN_2_DECODER_COUNT	 u24(23:0)	This register displays the actual count of encoder steps. It can be overwritten for initialization. Raw decoder_2 count; the digital decoder engine counts modulo (decoder_2_ppr).
0x2F _h	ABN_2_DECODER_COUNT_N ABN_2_DECODER_COUNT_N	 u24(23:0)	This register displays the count value at last N pulse event. It can also be used to overwrite decoder count at N pulse event according to decoder mode register setting. Decoder_2 count latched on N pulse, when N pulse clears decoder_2_count also decoder_2_count_n is 0.
0x30 _h	ABN_2_DECODER_PHI_M_OFFSET ABN_2_DECODER_PHI_M_OFFSET	 s16(15:0)	This register can be used to set offsets for electrical and mechanical angle calculated from decoder. ABN_2_DECODER_PHI_M_OFFSET to shift (rotate) angle DECODER_2_PHI_M.
0x31 _h	ABN_2_DECODER_PHI_M ABN_2_DECODER_PHI_M	 s16(15:0)	This register displays actual angle values for ABN encoder. $ABN_2_DECODER_PHI_M = ABN_2_DECODER_COUNT * 2^{16} / ABN_2_DECODER_PPR + ABN_2_DECODER_PHI_M_OFFSET;$
0x33 _h	HALL_MODE polarity synchronous PWM sampling interpolation direction	 bit(0) bit(4) bit(8) bit(12)	This register is used to set basic settings for the digital Hall interface. polarity 0: off 1: on enable sampling synchronous to PWM 0: off 1: on interpolation 0: off 1: on direction 0: off 1: on



	HALL_BLANK	u12(27:16)	tBLANK = 10ns * HALL_BLANK
0x34 _h	HALL_POSITION_060_000		This register is used to calibrate hall sensor offset.
	HALL_POSITION_000	s16(15:0)	s16 hall sensor position at 0°
	HALL_POSITION_060	s16(31:16)	s16 hall sensor position at 60°.
0x35 _h	HALL_POSITION_180_120		This register is used to calibrate hall sensor offset.
	HALL_POSITION_120	s16(15:0)	s16 hall sensor position at 120°.
	HALL_POSITION_180	s16(31:16)	s16 hall sensor position at 180°.
0x36 _h	HALL_POSITION_300_240		This register is used to calibrate hall sensor offset.
	HALL_POSITION_240	s16(15:0)	s16 hall sensor position at 240°.
	HALL_POSITION_300	s16(31:16)	s16 hall sensor position at 300°.
0x37 _h	HALL_PHI_E_PHI_M_OFFSET		This register is used to set offsets for calculated angles from hall interface.
	HALL_PHI_M_OFFSET	s16(15:0)	Offset of mechanical angle hall_phi_m of hall decoder.
	HALL_PHI_E_OFFSET	s16(31:16)	Offset for electrical angle hall_phi_e of hall decoder.
0x38 _h	HALL_DPHI_MAX		This register is used to set a maxim difference of two hall sensor transitions for Hall position extrapolation.
	HALL_DPHI_MAX	u16(15:0)	Maximum dx for interpolation (default for digital hall: u16/6).
0x39 _h	HALL_PHI_E_INTERPOLATED_PHI_E		This register displays interpolated and raw angle of Hall interface.
	HALL_PHI_E	s16(15:0)	Raw electrical angle hall_phi_e of hall decoder, selection programmed via HALL_MODE control bit.
	HALL_PHI_E_INTERPOLATED	s16(31:16)	Interpolated electrical angle hall_phi_e_interpolated, selection programmed via HALL_MODE control bit.
0x3A _h	HALL_PHI_M		This register displays the mechanical angle calculated in Hall sensor interface.
	HALL_PHI_M	s16(15:0)	Mechanical angle hall_phi_m of hall decoder.



0x3B _h	AENC_DECODER_MODE		This register sets basic information for the analog encoder interface.
	AENC_DECODER_MODE[0]	bit(0)	120deg_n90deg 0: 90 degree 1: 120 degree
	AENC_DECODER_MODE[12]	bit(12)	decoder count direction 0: positive 1: negative
0x3C _h	AENC_DECODER_N_THRESHOLD		This registers sets analog encoder N pulse processing function.
	AENC_DECODER_N_THRESHOLD	u16(15:0)	Threshold for generating of N pulse from analog AENC_N signal (only needed for analog SinCos encoders with analog N signal).
	AENC_DECODER_N_MASK	s16(31:16)	Optional position mask (position) for the analog N pulse within phi_a period to be and-ed with the digital N pulse generated via aenc_decoder_n_threshold.
0x3D _h	AENC_DECODER_PHI_A_RAW		Displays raw angle after ATAN2 calculation.
	AENC_DECODER_PHI_A_RAW	s16(15:0)	Raw analog angle phi calculated from analog AENC inputs (analog hall, analog SinCos, ...).
0x3E _h	AENC_DECODER_PHI_A_OFFSET		This register sets the offset of PHI_A for phase alignment.
	AENC_DECODER_PHI_A_OFFSET	s16(15:0)	Offset for angle phi from analog decoder (analog hall, analog SinCos, ...).
0x3F _h	AENC_DECODER_PHI_A		This register displays offset compensated PHI_A angle.
	AENC_DECODER_PHI_A	s16(15:0)	Resulting phi available for the FOC (phi_e might need to be calculated from this angle via aenc_decoder_ppr, for analog hall sensors phi_a might be used directly as phi_e depends on analog hall signal type).
0x40 _h	AENC_DECODER_PPR		This register sets the number of periods per revolution for analog encoder.



	AENC_DECODER_PPR	s16(15:0)	Number of periods per revolution also called lines per revolution (different nomenclatur compared to digital ABN encoders).
0x41 _h	AENC_DECODER_COUNT		Displays the count value of Analog encoder periods.
	AENC_DECODER_COUNT	s32(31:0)	Decoder position, raw unscaled.
0x42 _h	AENC_DECODER_COUNT_N		Displays the count value at last N pulse event. Can also be used to auto-overwrite decoder count at N pulse event.
	AENC_DECODER_COUNT_N	s32(31:0)	Latched decoder position on analog N pulse event.
0x45 _h	AENC_DECODER_PHI_E_PHI_M_OFFSET		This register sets offsets for electrical and mechanical angle calculated from AENC interface.
	AENC_DECODER_PHI_M_OFFSET	s16(15:0)	Offset for mechanical angle phi _m .
	AENC_DECODER_PHI_E_OFFSET	s16(31:16)	Offset for electrical angle phi _e .
0x46 _h	AENC_DECODER_PHI_E_PHI_M		Displays actual angle values of analog encoder interface.
	AENC_DECODER_PHI_M	s16(15:0)	Resulting angle phi _m .
	AENC_DECODER_PHI_E	s16(31:16)	Resulting angle phi _e .
0x4B _h	PIDIN_VELOCITY_TARGET		Displays actual target velocity at input of velocity controller.
	PIDIN_VELOCITY_TARGET	s32(31:0)	Target velocity at PI controller input.
0x4C _h	PIDIN_POSITION_TARGET		Displays actual target position at input of position controller.
	PIDIN_POSITION_TARGET	s32(31:0)	Target position at PI controller input.
0x4D _h	CONFIG_DATA		This multi-purpose register is used to set configuration parameters of controller cascade and input signal conditioning.
	biquad_x_a_1	s32(31:0)	
	biquad_x_a_2	s32(31:0)	
	biquad_x_b_0	s32(31:0)	
	biquad_x_b_1	s32(31:0)	
	biquad_x_b_2	s32(31:0)	
	biquad_x_enable	bit(31)	



biquad_v_a_1	s32(31:0)	
biquad_v_a_2	s32(31:0)	
biquad_v_b_0	s32(31:0)	
biquad_v_b_1	s32(31:0)	
biquad_v_b_2	s32(31:0)	
biquad_v_enable	bit(31)	0: off 1: on
biquad_t_a_1	s32(31:0)	
biquad_t_a_2	s32(31:0)	
biquad_t_b_0	s32(31:0)	
biquad_t_b_1	s32(31:0)	
biquad_t_b_2	s32(31:0)	
biquad_t_enable	bit(31)	0: off 1: on
biquad_f_a_1	s32(31:0)	
biquad_f_a_2	s32(31:0)	
biquad_f_b_0	s32(31:0)	
biquad_f_b_1	s32(31:0)	
biquad_f_b_2	s32(31:0)	
biquad_f_enable	bit(31)	0: off 1: on
prbs_amplitude	s32(31:0)	
prbs_down_sampling_ratio	s32(31:0)	
ref_switch_config	u16(15:0)	
Encoder_Init_hall_Enable	bit(0)	0: off 1: on
SINGLE_PIN_IF_CFG	u8(7:0)	
SINGLE_PIN_IF_STATUS	u16(31:16)	
SINGLE_PIN_IF_OFFSET	u16(15:0)	Offset for scaling of Single pin Interface input
SINGLE_PIN_IF_SCALE	s16(31:16)	Gain factor of Single pin Interface input
CURRENT_I_nQ8.8_Q4.12	bit(0)	If this bit is set Q4.12 representation of I parameter for torque/flux control is used. If bit is not set Q8.8 representation is used 0: Q8.8 representation is used 1: Q4.12 representation is used



	CURRENT_P_nQ8.8_Q4.12	bit(1)	<p>If this bit is set Q4.12 representation of P for parameter for torque/flux control is used. If bit is not set Q8.8 representation is used</p> <p>0: Q8.8 representation is used 1: Q4.12 representation is used</p>
	VELOCITY_I_nQ8.8_Q4.12	bit(2)	<p>If this bit is set Q4.12 representation of I parameter for velocity control is used. If bit is not set Q8.8 representation is used</p> <p>0: Q8.8 representation is used 1: Q4.12 representation is used</p>
	VELOCITY_P_nQ8.8_Q4.12	bit(3)	<p>If this bit is set Q4.12 representation of P for parameter for velocity control is used. If bit is not set Q8.8 representation is used</p> <p>0: Q8.8 representation is used 1: Q4.12 representation is used</p>
	POSITION_I_nQ8.8_Q4.12	bit(4)	<p>If this bit is set Q4.12 representation of I parameter for position control is used. If bit is not set Q8.8 representation is used</p> <p>0: Q8.8 representation is used 1: Q4.12 representation is used</p>
	POSITION_P_nQ8.8_Q4.12	bit(5)	<p>If this bit is set Q4.12 representation of P for parameter for position control is used. If bit is not set Q8.8 representation is used</p> <p>0: Q8.8 representation is used 1: Q4.12 representation is used</p>
0x4E _h	CONFIG_ADDR		<p>This register is used to select function of CONFIG_DATA register.</p> <p>1: biquad_x_a_1 2: biquad_x_a_2 4: biquad_x_b_0 5: biquad_x_b_1 6: biquad_x_b_2 7: biquad_x_enable 9: biquad_v_a_1 10: biquad_v_a_2 12: biquad_v_b_0</p>
	CONFIG_ADDR	u32(31:0)	



			<ul style="list-style-type: none"> 13: biquad_v_b_1 14: biquad_v_b_2 15: biquad_v_enable 17: biquad_t_a_1 18: biquad_t_a_2 20: biquad_t_b_0 21: biquad_t_b_1 22: biquad_t_b_2 23: biquad_t_enable 25: biquad_f_a_1 26: biquad_f_a_2 28: biquad_f_b_0 29: biquad_f_b_1 30: biquad_f_b_2 31: biquad_f_enable 32: prbs_amplitude 33: prbs_down_sampling_ratio 51: ref_switch_config 52: Encoder_Init_hall_Enable 60: SINGLE_PIN_IF_STATUS_CFG 61: SINGLE_PIN_IF_SCALE_OFFSET 62: ADVANCED_PI_REPRESENT.
0x50 _h	VELOCITY_SELECTION		
	VELOCITY_SELECTION	u8(7:0)	<p>This register is used to select an angle signal for the velocity control loop and velocity calculation.</p> <p>Selects the source of the velocity source for velocity measurement.</p> <ul style="list-style-type: none"> 0: PHI_E_SELECTION 1: phi_e_ext 2: phi_e_openloop 3: phi_e_abn 4: reserved 5: phi_e_hal 6: phi_e_aenc 7: phi_a_aenc 8: reserved 9: phi_m_abn



	VELOCITY_METER_SELECTION	u8(15:8)	<ul style="list-style-type: none"> 10: phi_m_abn_2 11: phi_m_aenc 12: phi_m_hal 0: default 1: advanced
0x51 _h	POSITION_SELECTION POSITION_SELECTION	u8(7:0)	<p>This register is used to select an angle signal for the position calculation and control loop.</p> <ul style="list-style-type: none"> 0: phi_e selected via PHI_E_SELECTION 1: phi_e_ext 2: phi_e_openloop 3: phi_e_abn 4: reserved 5: phi_e_hal 6: phi_e_aenc 7: phi_a_aenc 8: reserved 9: phi_m_abn 10: phi_m_abn_2 11: phi_m_aenc 12: phi_m_hal
0x52 _h	PHI_E_SELECTION PHI_E_SELECTION	u8(7:0)	<p>This register is used to select an angle signal for FOC transformation as electrical angle of the motor.</p> <ul style="list-style-type: none"> 0: reserved 1: phi_e_ext 2: phi_e_openloop 3: phi_e_abn 4: reserved 5: phi_e_hal 6: phi_e_aenc 7: phi_a_aenc
0x53 _h	PHI_E PHI_E	s16(15:0)	<p>This register displays the actual chosen electrical angle value.</p> <p>Angle used for the inner FOC loop.</p>



0x54 _h	PID_FLUX_P_FLUX_I PID_FLUX_I PID_FLUX_P	 s16(15:0) s16(31:16)	This registers sets control parameters for flux controller.
0x56 _h	PID_TORQUE_P_TORQUE_I PID_TORQUE_I PID_TORQUE_P	 s16(15:0) s16(31:16)	This registers sets control parameters for torque controller.
0x58 _h	PID_VELOCITY_P_VELOCITY_I PID_VELOCITY_I PID_VELOCITY_P	 s16(15:0) s16(31:16)	This registers sets control parameters for velocity controller.
0x5A _h	PID_POSITION_P_POSITION_I PID_POSITION_I PID_POSITION_P	 s16(15:0) s16(31:16)	This registers sets control parameters for position controller.
0x5D _h	PIDOUT_UQ_UD_LIMITS PIDOUT_UQ_UD_LIMITS	 s16(15:0)	<p>This register sets the output voltage/duty cycle limit for the current controllers. iPARK CIRLIM block limits voltage output vector length to this value.</p> <p>Two dimensional circular limiter for inputs of iPark. HINT: The absolute value of the register is used (possible values: 0 ... 32767).</p>
0x5E _h	PID_TORQUE_FLUX_LIMITS PID_TORQUE_FLUX_LIMITS	 u16(15:0)	<p>This register is used to set target current limit for both controllers.</p> <p>PID torque limit and PID flux limit, limits the target values coming from the target registers.</p>
0x60 _h	PID_VELOCITY_LIMIT PID_VELOCITY_LIMIT	 u32(31:0)	<p>This register is used to set an absolute velocity limit for velocity controller input.</p> <p>Velocity limit.</p>
0x61 _h	PID_POSITION_LIMIT_LOW PID_POSITION_LIMIT_LOW	 s32(31:0)	<p>This register is used to set a lower limit for position controller input.</p> <p>Position limit low, programmable position barrier.</p>
0x62 _h	PID_POSITION_LIMIT_HIGH PID_POSITION_LIMIT_HIGH	 s32(31:0)	<p>This register is used to set a higher limit for position controller input.</p> <p>Position limit high, programmable position barrier.</p>



0x63 _h	MODE_RAMP_MODE_MOTION		This register is used to set a motion mode, a downsampling factor for velocity and position control loop, and the PI controller structure type.
	MODE_MOTION	u8(7:0)	<ul style="list-style-type: none"> 0: stopped_mode 1: torque_mode 2: velocity_mode 3: position_mode 4: prbs_flux_mode 5: prbs_torque_mode 6: prbs_velocity_mode 7: prbs_position_mode 8: uq_ud_ext 9: reserved 10: AGPI_A torque_mode 11: AGPI_A velocity_mode 12: AGPI_A position_mode 13: PWM_I torque_mode 14: PWM_I velocity_mode 15: PWM_I position_mode
	MODE_PID_SMPL	u7(30:24)	
	MODE_PID_TYPE	bit(31)	<ul style="list-style-type: none"> 0: parallel/classic PI 1: sequential/advanced PI
0x64 _h	PID_TORQUE_FLUX_TARGET		Target values for torque and flux controllers in torque mode.
	PID_FLUX_TARGET	s16(15:0)	
	PID_TORQUE_TARGET	s16(31:16)	
0x65 _h	PID_TORQUE_FLUX_OFFSET		Offsets for software torque and flux control loop inputs for feed-forward control.
	PID_FLUX_OFFSET	s16(15:0)	Flux offset for feed forward control.
	PID_TORQUE_OFFSET	s16(31:16)	Torque offset for feed forward control.
0x66 _h	PID_VELOCITY_TARGET		Target velocity value for velocity controller in velocity mode.
	PID_VELOCITY_TARGET	s32(31:0)	Target velocity register (for velocity mode).



0x67 _h	PID_VELOCITY_OFFSET		Offset velocity value for velocity controller in velocity and position mode.
	PID_VELOCITY_OFFSET	s32(31:0)	Velocity offset for feed forward control.
0x68 _h	PID_POSITION_TARGET		Target position value for position controller in position mode.
	PID_POSITION_TARGET	s32(31:0)	Target position register (for position mode).
0x69 _h	PID_TORQUE_FLUX_ACTUAL		Target position offset value for position controller in position mode.
	PID_FLUX_ACTUAL	s16(15:0)	
	PID_TORQUE_ACTUAL	s16(31:16)	
0x6A _h	PID_VELOCITY_ACTUAL		Filtered actual velocity derived from chosen angle signal.
	PID_VELOCITY_ACTUAL	s32(31:0)	Actual velocity.
0x6B _h	PID_POSITION_ACTUAL		Actual position derived from chosen position signal.
	PID_POSITION_ACTUAL	s32(31:0)	Actual multi turn position for positioning. Input position differences are accumulated. Lower 16 bits display one revolution of input angle. Upper 16 bits display revolutions. WRITE on PID_POSITION_ACTUAL writes same value into PID_POSITION_TARGET to avoid unwanted move.
0x6C _h	PID_ERROR_DATA		Register displays control errors of controllers for testing according to selection PID_ERROR_ADDR.
	PID_TORQUE_ERROR	s32(31:0)	PID torque error.
	PID_FLUX_ERROR	s32(31:0)	PID flux error.
	PID_VELOCITY_ERROR	s32(31:0)	PID velocity error.
	PID_POSITION_ERROR	s32(31:0)	PID position error.
	PID_TORQUE_ERROR_SUM	s32(31:0)	PID torque error sum.
	PID_FLUX_ERROR_SUM	s32(31:0)	PID flux error sum.
	PID_VELOCITY_ERROR_SUM	s32(31:0)	PID velocity error sum.
0x6D _h	PID_ERROR_ADDR		Register is used to set function of PID_ERROR_DATA register.
	PID_ERROR_ADDR	u8(7:0)	0: PID_TORQUE_ERROR 1: PID_FLUX_ERROR



			2: PID_VELOCITY_ERROR 3: PID_POSITION_ERROR 4: PID_TORQUE_ERROR_SUM 5: PID_FLUX_ERROR_SUM 6: PID_VELOCITY_ERROR_SUM 7: PID_POSITION_ERROR_SUM
0x6E _h	INTERIM_DATA		This register is used to display internal signals from controller cascade for monitoring.
	PIDIN_TARGET_TORQUE	s32(31:0)	PIDIN target torque.
	PIDIN_TARGET_FLUX	s32(31:0)	PIDIN target flux.
	PIDIN_TARGET_VELOCITY	s32(31:0)	PIDIN target velocity.
	PIDIN_TARGET_POSITION	s32(31:0)	PIDIN target position.
	PIDOUT_TARGET_TORQUE	s32(31:0)	PIDOUT target torque.
	PIDOUT_TARGET_FLUX	s32(31:0)	PIDOUT target flux.
	PIDOUT_TARGET_VELOCITY	s32(31:0)	PIDOUT target velocity.
	PIDOUT_TARGET_POSITION	s32(31:0)	PIDOUT target position.
	FOC_IUX	s16(15:0)	
	FOC_IWY	s16(31:16)	
	FOC_IV	s16(15:0)	
	FOC_IA	s16(15:0)	
	FOC_IB	s16(31:16)	
	FOC_ID	s16(15:0)	
	FOC_IQ	s16(31:16)	
	FOC_UD	s16(15:0)	
	FOC_UQ	s16(31:16)	
	FOC_UD_LIMITED	s16(15:0)	
	FOC_UQ_LIMITED	s16(31:16)	
	FOC_UA	s16(15:0)	
	FOC_UB	s16(31:16)	
	FOC_UUX	s16(15:0)	
	FOC_UWY	s16(31:16)	
	FOC_UV	s16(15:0)	
	PWM_UX	s16(15:0)	
	PWM_WY	s16(31:16)	
	PWM_V	s16(15:0)	
	ADC_I_0	s16(15:0)	



	ADC_I_1	s16(31:16)	
	PID_FLUX_ACTUAL_DIV256	s8(7:0)	
	PID_TORQUE_ACTUAL_DIV256	s8(15:8)	
	PID_FLUX_TARGET_DIV256	s8(23:16)	
	PID_TORQUE_TARGET_DIV256	s8(31:24)	
	PID_TORQUE_ACTUAL	s16(15:0)	
	PID_TORQUE_TARGET	s16(31:16)	
	PID_FLUX_ACTUAL	s16(15:0)	
	PID_FLUX_TARGET	s16(31:16)	
	PID_VELOCITY_ACTUAL_DIV256	s16(15:0)	
	PID_VELOCITY_TARGET_DIV256	s16(31:16)	
	PID_VELOCITY_ACTUAL_LSB	s16(15:0)	
	PID_VELOCITY_TARGET_LSB	s16(31:16)	
	PID_POSITION_ACTUAL_DIV256	s16(15:0)	
	PID_POSITION_TARGET_DIV256	s16(31:16)	
	PID_POSITION_ACTUAL_LSB	s16(15:0)	
	PID_POSITION_TARGET_LSB	s16(31:16)	
	FF_VELOCITY	s32(31:0)	
	FF_TORQUE	s16(15:0)	
	ACTUAL_VELOCITY_PPTM	s32(31:0)	
	REF_SWITCH_STATUS	u16(15:0)	
	HOME_POSITION	s32(31:0)	
	LEFT_POSITION	s32(31:0)	
	RIGHT_POSITION	s32(31:0)	
	ENC_INIT_HALL_STATUS	u16(15:0)	
	ENC_INIT_HALL_PHI_E_ABN_OFFSET	u16(15:0)	
	ENC_INIT_HALL_PHI_E_AENC_OFFSET	u16(15:0)	
	ENC_INIT_HALL_PHI_A_AENC_OFFSET	u16(15:0)	
	SINGLE_PIN_IF_TARGET_TORQUE	s16(15:0)	
	SINGLE_PIN_IF_PWM_DUTY_CYCLE	s16(31:16)	
	SINGLE_PIN_IF_TARGET_VELOCITY	s32(31:0)	
	SINGLE_PIN_IF_TARGET_POSITION	s32(31:0)	
0x6F _h	INTERIM_ADDR		Sets function of register INTERIM_DATA.
	INTERIM_ADDR	u8(7:0)	0: PIDIN_TARGET_TORQUE 1: PIDIN_TARGET_FLUX



2: PIDIN_TARGET_VELOCITY
3: PIDIN_TARGET_POSITION
4: PIDOUT_TARGET_TORQUE
5: PIDOUT_TARGET_FLUX
6: PIDOUT_TARGET_VELOCITY
7: PIDOUT_TARGET_POSITION
8: FOC_IWY_IUX
9: FOC_IV
10: FOC_IB_IA
11: FOC_IQ_ID
12: FOC_UQ_UD
13: FOC_UQ_UD_LIMITED
14: FOC_UB_UA
15: FOC_UWY_UUX
16: FOC_UV
17: PWM_WY_UX
18: PWM_UV
19: ADC_I1_I0
20: PID_TORQUE_TARGET_FLUX_
TARGET_TORQUE_ACTUAL_FLUX_
ACTUAL_DIV256
21: PID_TORQUE_TARGET_
TORQUE_ACTUAL
22: PID_FLUX_TARGET_FLUX_
ACTUAL
23: PID_VELOCITY_TARGET_
VELOCITY_ACTUAL_DIV256
24: PID_VELOCITY_TARGET_
VELOCITY_ACTUAL
25: PID_POSITION_TARGET_
POSITION_ACTUAL_DIV256
26: PID_POSITION_TARGET_
POSITION_ACTUAL
27: FF_VELOCITY
28: FF_TORQUE
29: ACTUAL_VELOCITY_PPTM
30: REF_SWITCH_STATUS
31: HOME_POSITION
32: LEFT_POSITION



0x75 _h	ADC_VM_LIMITS		33: RIGHT_POSITION 34: ENC_INIT_HALL_STATUS 35: ENC_INIT_HALL_PHI_E_ABN_OFFSET 36: ENC_INIT_HALL_PHI_E_AENC_OFFSET 37: ENC_INIT_HALL_PHI_A_AENC_OFFSET 42: SINGLE_PIN_IF_PWM_DUTY_CYCLE_TORQUE_TARGET 43: SINGLE_PIN_IF_VELOCITY_TARGET 44: SINGLE_PIN_IF_POSITION_TARGET
	ADC_VM_LIMIT_LOW	u16(15:0)	Sets supply voltage limits for brake chopper output action. Low limit for brake chopper output BRAKE_OUT.
	ADC_VM_LIMIT_HIGH	u16(31:16)	High limit for brake chopper output BRAKE_OUT.
	0x76 _h TMC4671_INPUTS_RAW		
	A of ABN_RAW	bit(0)	Displays actual input signals of IC for monitoring and connection testing. A of ABN_RAW 0: off 1: on
	B of ABN_RAW	bit(1)	B of ABN_RAW 0: off 1: on
	N of ABN_RAW	bit(2)	N of ABN_RAW 0: off 1: on
	-	bit(3)	— 0: off 1: on
	A of ABN_2_RAW	bit(4)	A of ABN_2_RAW 0: off 1: on
	B of ABN_2_RAW	bit(5)	B of ABN_2_RAW 0: off



N of ABN_2_RAW	bit(6)	1: on N of ABN_2_RAW 0: off
-	bit(7)	1: on — 0: off
HALL_UX of HALL_RAW	bit(8)	1: on HALL_UX of HALL_RAW 0: off
HALL_V of HALL_RAW	bit(9)	1: on HALL_V of HALL_RAW 0: off
HALL_WY of HALL_RAW	bit(10)	1: on HALL_WY of HALL_RAW 0: off
-	bit(11)	1: on — 0: off
REF_SW_R_RAW	bit(12)	1: on REF_SW_R_RAW 0: off
REF_SW_H_RAW	bit(13)	1: on REF_SW_H_RAW 0: off
REF_SW_L_RAW	bit(14)	1: on REF_SW_L_RAW 0: off
ENABLE_IN_RAW	bit(15)	1: on ENABLE_IN_RAW 0: off
STP of DIRSTP_RAW	bit(16)	1: on STP of DIRSTP_RAW 0: off
DIR of DIRSTP_RAW	bit(17)	1: on DIR of DIRSTP_RAW 0: off



PWM_IN_RAW	bit(18)	1: on PWM_IN_RAW 0: off
-	bit(19)	1: on — 0: off
HALL_UX_FILT	bit(20)	1: on ESI_0 of ESI_RAW 0: off
HALL_V_FILT	bit(21)	1: on ESI_1 of ESI_RAW 0: off
HALL_WY_FILT	bit(22)	1: on ESI_2 of ESI_RAW 0: off
-	bit(23)	1: on — 0: off
-	bit(24)	1: on CFG_0 of CFG 0: off
-	bit(25)	1: on CFG_1 of CFG 0: off
-	bit(26)	1: on CFG_2 of CFG 0: off
-	bit(27)	1: on CFG_3 of CFG 0: off
PWM_IDLE_L_RAW	bit(28)	1: on PWM_IDLE_L_RAW 0: off
PWM_IDLE_H_RAW	bit(29)	1: on PWM_IDLE_H_RAW 0: off



	-	bit(30)	1: on DRV_ERR_IN_RAW 0: off
	-	bit(31)	1: on — 0: off 1: on
0x77 _h	TMC4671_OUTPUTS_RAW		Displays actual output signals of IC for monitoring and connection testing.
	TMC4671_OUTPUTS_RAW[0]	bit(0)	PWM_UX1_L 0: off 1: on
	TMC4671_OUTPUTS_RAW[1]	bit(1)	PWM_UX1_H 0: off 1: on
	TMC4671_OUTPUTS_RAW[2]	bit(2)	PWM_VX2_L 0: off 1: on
	TMC4671_OUTPUTS_RAW[3]	bit(3)	PWM_VX2_H 0: off 1: on
	TMC4671_OUTPUTS_RAW[4]	bit(4)	PWM_WY1_L 0: off 1: on
	TMC4671_OUTPUTS_RAW[5]	bit(5)	PWM_WY1_H 0: off 1: on
	TMC4671_OUTPUTS_RAW[6]	bit(6)	PWM_Y2_L 0: off 1: on
	TMC4671_OUTPUTS_RAW[7]	bit(7)	PWM_Y2_H 0: off 1: on



0x78 _h	STEP_WIDTH		Sets a Step width of an acutal input step signal on STEP/DIR interface. Target position is decreased/increased by this value according to Dir signal.
	STEP_WIDTH	s32(31:0)	STEP WIDTH = 0 => STP pulses ignored, resulting direction = DIR XOR sign(STEP_WIDTH), effects PID_POSITION_TARGET
0x79 _h	UART_BPS		Sets the desired UART baudrate. Must be entered as hexadecimal number (e.g baudrate 9600 is set by entering 0x00009600 _h)
	UART_BPS	u24(23:0)	0x00009600 _h , 0x00115200 _h , 0x00921600 _h , 0x03000000 _h (default=0x00009600)
0x7B _h	GPIO_dsADCI_CONFIG		Sets the function and controls the GPIOs if RTMI is not used. Check functional description for detailed explanation of options.
	GPIO_dsADCI_CONFIG[0]	bit(0)	SEL_nDBGSPIM_GPIO 0: off 1: on
	GPIO_dsADCI_CONFIG[1]	bit(1)	SEL_nGPIO_dsADCS_A 0: off 1: on
	GPIO_dsADCI_CONFIG[2]	bit(2)	SEL_nGPIO_dsADCS_B 0: off 1: on
	GPIO_dsADCI_CONFIG[3]	bit(3)	SEL_GPIO_GROUP_A_nIN_OUT 0: off 1: on
	GPIO_dsADCI_CONFIG[4]	bit(4)	SEL_GPIO_GROUP_B_nIN_OUT 0: off 1: on
	GPIO_dsADCI_CONFIG[5]	bit(5)	SEL_GROUP_A_DSADCS_nCLKIN_CLKOUT 0: off 1: on
	GPIO_dsADCI_CONFIG[6]	bit(6)	SEL_GROUP_B_DSADCS_nCLKIN_CLKOUT



	GPO	u8(23:16)	0: off 1: on
	GPI	u8(31:24)	
0x7C _h	STATUS_FLAGS		Displays actual status flags to set status output. The register is also used to reset status flags.
	STATUS_FLAGS[0]	bit(0)	pid_x_target_limit 0: off 1: on
	STATUS_FLAGS[1]	bit(1)	pid_x_target_ddt_limit 0: off 1: on
	STATUS_FLAGS[2]	bit(2)	pid_x_errsum_limit 0: off 1: on
	STATUS_FLAGS[3]	bit(3)	pid_x_output_limit 0: off 1: on
	STATUS_FLAGS[4]	bit(4)	pid_v_target_limit 0: off 1: on
	STATUS_FLAGS[5]	bit(5)	pid_v_target_ddt_limit 0: off 1: on
	STATUS_FLAGS[6]	bit(6)	pid_v_errsum_limit 0: off 1: on
	STATUS_FLAGS[7]	bit(7)	pid_v_output_limit 0: off 1: on
	STATUS_FLAGS[8]	bit(8)	pid_id_target_limit 0: off 1: on
	STATUS_FLAGS[9]	bit(9)	pid_id_target_ddt_limit 0: off 1: on



STATUS_FLAGS[10]	bit(10)	pid_id_errsum_limit 0: off 1: on
STATUS_FLAGS[11]	bit(11)	pid_id_output_limit 0: off 1: on
STATUS_FLAGS[12]	bit(12)	pid_iq_target_limit 0: off 1: on
STATUS_FLAGS[13]	bit(13)	pid_iq_target_ddt_limit 0: off 1: on
STATUS_FLAGS[14]	bit(14)	pid_iq_errsum_limit 0: off 1: on
STATUS_FLAGS[15]	bit(15)	pid_iq_output_limit 0: off 1: on
STATUS_FLAGS[16]	bit(16)	ipark_cirlim_limit_u_d 0: off 1: on
STATUS_FLAGS[17]	bit(17)	ipark_cirlim_limit_u_q 0: off 1: on
STATUS_FLAGS[18]	bit(18)	ipark_cirlim_limit_u_r 0: off 1: on
STATUS_FLAGS[19]	bit(19)	not_PLL_locked 0: off 1: on
STATUS_FLAGS[20]	bit(20)	ref_sw_r 0: off 1: on
STATUS_FLAGS[21]	bit(21)	ref_sw_h 0: off 1: on



	STATUS_FLAGS[22]	bit(22)	ref_sw_l 0: off 1: on
	STATUS_FLAGS[23]	bit(23)	— 0: off 1: on
	STATUS_FLAGS[24]	bit(24)	pwm_min 0: off 1: on
	STATUS_FLAGS[25]	bit(25)	pwm_max 0: off 1: on
	STATUS_FLAGS[26]	bit(26)	adc_i_clipped 0: off 1: on
	STATUS_FLAGS[27]	bit(27)	aenc_clipped 0: off 1: on
	STATUS_FLAGS[28]	bit(28)	enc_n 0: off 1: on
	STATUS_FLAGS[29]	bit(29)	enc_2_n 0: off 1: on
	STATUS_FLAGS[30]	bit(30)	aenc_n 0: off 1: on
	STATUS_FLAGS[31]	bit(31)	reserved 0: off 1: on
0x7D _h	STATUS_MASK		Register is used to set a mask for STATUS_FLAGS register to set STATUS output pin.
	STATUS_MASK	u32(31:0)	



7.3 Register Map - Defaults, Data Fields (Bit Masks), min, max

RD/WR	ADDR	NAME	DEFAULT	MIN	MAX	COMMENT
R	0x00 _h	CHIPINFO_DATA				
		SI_TYPE	0x0 _h	0x0 _h	0xFFFFFFFF _h	
		SI_VERSION	0x0 _h	0x0 _h	0xFFFFFFFF _h	
		SI_DATE	0x0 _h	0x0 _h	0xFFFFFFFF _h	
		SI_TIME	0x0 _h	0x0 _h	0xFFFFFF _h	
		SI_VARIANT	0x0 _h	0x0 _h	0xFFFFFFFF _h	
		SI_BUILD	0x0 _h	0x0 _h	0xFFFFFFFF _h	
RW	0x01 _h	CHIPINFO_ADDR				
		CHIP_INFO_ADDRESS	0x0 _h	0x0 _h	0x5 _h	
R	0x02 _h	ADC_RAW_DATA				
		ADC_I0_RAW	0x0 _h	0x0 _h	0xFFFF _h	
		ADC_I1_RAW	0x0 _h	0x0 _h	0xFFFF _h	
		ADC_VM_RAW	0x0 _h	0x0 _h	0xFFFF _h	
		ADC_AGPI_A_RAW	0x0 _h	0x0 _h	0xFFFF _h	
		ADC_AGPI_B_RAW	0x0 _h	0x0 _h	0xFFFF _h	
		ADC_AENC_UX_RAW	0x0 _h	0x0 _h	0xFFFF _h	
		ADC_AENC_VN_RAW	0x0 _h	0x0 _h	0xFFFF _h	
		ADC_AENC_WY_RAW	0x0 _h	0x0 _h	0xFFFF _h	
RW	0x03 _h	ADC_RAW_ADDR				
		ADC_RAW_ADDR	0x0 _h	0x0 _h	0x3 _h	
RW	0x04 _h	dsADC_MCFG_B_MCFG_A				
		cfg_dsmodulator_a	0x0 _h	0x0 _h	0x3 _h	
		mclk_polarity_a	0x0 _h	0x0 _h	0x1 _h	
		mdat_polarity_a	0x0 _h	0x0 _h	0x1 _h	
		sel_nclk_mclk_i_a	0x0 _h	0x0 _h	0x1 _h	
		blanking_a	0x0 _h	0x0 _h	0xFF _h	
		cfg_dsmodulator_b	0x0 _h	0x0 _h	0x3 _h	
		mclk_polarity_b	0x0 _h	0x0 _h	0x1 _h	
		mdat_polarity_b	0x0 _h	0x0 _h	0x1 _h	
		sel_nclk_mclk_i_b	0x0 _h	0x0 _h	0x1 _h	
		blanking_b	0x0 _h	0x0 _h	0xFF _h	
RW	0x05 _h	dsADC_MCLK_A				



		dsADC_MCLK_A	0xCCCCCD _h	0x0 _h	0xFFFFFFFF _h
RW	0x06 _h	dsADC_MCLK_B			
		dsADC_MCLK_B	0xCCCCCD _h	0x0 _h	0xFFFFFFFF _h
RW	0x07 _h	dsADC_MDEC_B			
		MDEC_A			
		dsADC_MDEC_A	0x100 _h	0x0 _h	0xFFFF _h
		dsADC_MDEC_B	0x100 _h	0x0 _h	0xFFFF _h
RW	0x08 _h	ADC_I1_SCALE_OFFSET			
		ADC_I1_OFFSET	0x0 _h	0x0 _h	0xFFFF _h
		ADC_I1_SCALE	0x100 _h	-0x8000 _h	0x7FFF _h
RW	0x09 _h	ADC_I0_SCALE_OFFSET			
		ADC_I0_OFFSET	0x0 _h	0x0 _h	0xFFFF _h
		ADC_I0_SCALE	0x100 _h	-0x8000 _h	0x7FFF _h
RW	0x0A _h	ADC_I_SELECT			
		ADC_I0_SELECT	0x0 _h	0x0 _h	0x3 _h
		ADC_I1_SELECT	0x1 _h	0x0 _h	0x3 _h
		ADC_I_UX_SELECT	0x0 _h	0x0 _h	0x2 _h
		ADC_I_V_SELECT	0x1 _h	0x0 _h	0x2 _h
		ADC_I_WY_SELECT	0x2 _h	0x0 _h	0x2 _h
RW	0x0B _h	ADC_I1_I0_EXT			
		ADC_I0_EXT	0x0 _h	0x0 _h	0xFFFF _h
		ADC_I1_EXT	0x0 _h	0x0 _h	0xFFFF _h
RW	0x0C _h	DS_ANALOG_INPUT_STAGE_CFG			
		ADC_I0	0x0 _h	0x0 _h	0x7 _h
		ADC_I1	0x0 _h	0x0 _h	0x7 _h
		ADC_VM	0x0 _h	0x0 _h	0x7 _h
		ADC_AGPI_A	0x0 _h	0x0 _h	0x7 _h
		ADC_AGPI_B	0x0 _h	0x0 _h	0x7 _h
		ADC_AENC_UX	0x0 _h	0x0 _h	0x7 _h
		ADC_AENC_VN	0x0 _h	0x0 _h	0x7 _h
		ADC_AENC_WY	0x0 _h	0x0 _h	0x7 _h
RW	0x0D _h	AENC_0_SCALE_OFFSET			
		AENC_0_OFFSET	0x0 _h	0x0 _h	0xFFFF _h



		AENC_0_SCALE	0x100 _h	-0x8000 _h	0x7FFF _h	
RW	0x0E _h	AENC_1_SCALE_OFFSET				
		AENC_1_OFFSET	0x0 _h	0x0 _h	0xFFFF _h	
		AENC_1_SCALE	0x100 _h	-0x8000 _h	0x7FFF _h	
RW	0x0F _h	AENC_2_SCALE_OFFSET				
		AENC_2_OFFSET	0x0 _h	0x0 _h	0xFFFF _h	
		AENC_2_SCALE	0x100 _h	-0x8000 _h	0x7FFF _h	
RW	0x11 _h	AENC_SELECT				
		AENC_0_SELECT	0x0 _h	0x0 _h	0x2 _h	
		AENC_1_SELECT	0x1 _h	0x0 _h	0x2 _h	
		AENC_2_SELECT	0x2 _h	0x0 _h	0x2 _h	
R	0x12 _h	ADC_IWY_IUX				
		ADC_IUX	0x0 _h	-0x8000 _h	0x7FFF _h	
		ADC_IWY	0x0 _h	-0x8000 _h	0x7FFF _h	
R	0x13 _h	ADC_IV				
		ADC_IV	0x0 _h	-0x8000 _h	0x7FFF _h	
R	0x15 _h	AENC_WY_UX				
		AENC_UX	0x0 _h	-0x8000 _h	0x7FFF _h	
		AENC_WY	0x0 _h	-0x8000 _h	0x7FFF _h	
R	0x16 _h	AENC_VN				
		AENC_VN	0x0 _h	-0x8000 _h	0x7FFF _h	
RW	0x17 _h	PWM_POLARITIES				
		PWM_POLARITIES[0]	0x0 _h	0x0 _h	0x1 _h	
		PWM_POLARITIES[1]	0x0 _h	0x0 _h	0x1 _h	
RW	0x18 _h	PWM_MAXCNT				
		PWM_MAXCNT	0xF9F _h	0x0 _h	0xFFFF _h	
RW	0x19 _h	PWM_BBM_H_BBM_L				
		PWM_BBM_L	0x14 _h	0x0 _h	0xFF _h	
		PWM_BBM_H	0x14 _h	0x0 _h	0xFF _h	
RW	0x1A _h	PWM_SV_CHOP				
		PWM_CHOP	0x0 _h	0x0 _h	0x7 _h	
		PWM_SV	0x0 _h	0x0 _h	0x1 _h	
RW	0x1B _h	MOTOR_TYPE_N_POLE_PAIRS				



		N_POLE_PAIRS	0x1 _h	0x1 _h	0xFFFF _h
		MOTOR_TYPE	0x0 _h	0x0 _h	0x3 _h
RW	0x1C _h	PHI_E_EXT			
		PHI_E_EXT	0x0 _h	-0x8000 _h	0x7FFF _h
RW	0x1F _h	OPENLOOP_MODE			
		OPENLOOP_PHI_DIRECTION	0x0 _h	0x0 _h	0x1 _h
RW	0x20 _h	OPENLOOP_ACCELERATION			
		OPENLOOP_ACCELERATION	0x0 _h	0x0 _h	0xFFFF _h
RW	0x21 _h	OPENLOOP_VELOCITY_TARGET			
		OPENLOOP_VELOCITY_TARGET	0x0 _h	-0x8000000 _h	0x7FFFFFF _h
RW	0x22 _h	OPENLOOP_VELOCITY_ACTUAL			
		OPENLOOP_VELOCITY_ACTUAL	0x0 _h	-0x8000000 _h	0x7FFFFFF _h
RWI	0x23 _h	OPENLOOP_PHI			
		OPENLOOP_PHI	0x0 _h	-0x8000 _h	0x7FFF _h
RW	0x24 _h	UQ_UD_EXT			
		UD_EXT	0x0 _h	-0x8000 _h	0x7FFF _h
		UQ_EXT	0x0 _h	-0x8000 _h	0x7FFF _h
RW	0x25 _h	ABN_DECODER_MODE			
		apol	0x0 _h	0x0 _h	0x1 _h
		bpol	0x0 _h	0x0 _h	0x1 _h
		npol	0x0 _h	0x0 _h	0x1 _h
		use_abn_as_n	0x0 _h	0x0 _h	0x1 _h
		cln	0x0 _h	0x0 _h	0x1 _h
		direction	0x0 _h	0x0 _h	0x1 _h
RW	0x26 _h	ABN_DECODER_PPR			
		ABN_DECODER_PPR	0x10000 _h	0x0 _h	0xFFFF _h
RW	0x27 _h	ABN_DECODER_COUNT			



		ABN_DECODER_COUNT	0x0 _h	0x0 _h	0xFFFFFFFF _h
RW	0x28 _h	ABN_DECODER_COUNT_N			
		ABN_DECODER_COUNT_N	0x0 _h	0x0 _h	0xFFFFFFFF _h
RW	0x29 _h	ABN_DECODER_PHI_E_PHI_M_OFFSET			
		ABN_DECODER_PHI_M_OFFSET	0x0 _h	-0x8000 _h	0x7FFF _h
		ABN_DECODER_PHI_E_OFFSET	0x0 _h	-0x8000 _h	0x7FFF _h
R	0x2A _h	ABN_DECODER_PHI_E_PHI_M			
		ABN_DECODER_PHI_M	0x0 _h	-0x8000 _h	0x7FFF _h
		ABN_DECODER_PHI_E	0x0 _h	-0x8000 _h	0x7FFF _h
RW	0x2C _h	ABN_2_DECODER_MODE			
		apol	0x0 _h	0x0 _h	0x1 _h
		bpol	0x0 _h	0x0 _h	0x1 _h
		npol	0x0 _h	0x0 _h	0x1 _h
		use_abn_as_n	0x0 _h	0x0 _h	0x1 _h
		cln	0x0 _h	0x0 _h	0x1 _h
		direction	0x0 _h	0x0 _h	0x1 _h
RW	0x2D _h	ABN_2_DECODER_PPR			
		ABN_2_DECODER_PPR	0x10000 _h	0x1 _h	0xFFFFFFFF _h
RW	0x2E _h	ABN_2_DECODER_COUNT			
		ABN_2_DECODER_COUNT	0x0 _h	0x0 _h	0xFFFFFFFF _h
RW	0x2F _h	ABN_2_DECODER_COUNT_N			
		ABN_2_DECODER_COUNT_N	0x0 _h	0x0 _h	0xFFFFFFFF _h
RW	0x30 _h	ABN_2_DECODER_PHI_M_OFFSET			



		ABN_2_DECODER_ PHI_M_OFFSET	0x0 _h	-0x8000 _h	0x7FFF _h
R	0x31 _h	ABN_2_DECODER_ PHI_M			
		ABN_2_DECODER_ PHI_M	0x0 _h	-0x8000 _h	0x7FFF _h
RW	0x33 _h	HALL_MODE			
		polarity	0x0 _h	0x0 _h	0x1 _h
		synchronous PWM sampling	0x0 _h	0x0 _h	0x1 _h
		interpolation	0x0 _h	0x0 _h	0x1 _h
		direction	0x0 _h	0x0 _h	0x1 _h
		HALL_BLANK	0x0 _h	0x0 _h	0xFFF _h
RW	0x34 _h	HALL_POSITION_060_000			
		HALL_POSITION_000	0x0 _h	-0x8000 _h	0x7FFF _h
		HALL_POSITION_060	0x2AAA _h	-0x8000 _h	0x7FFF _h
RW	0x35 _h	HALL_POSITION_180_120			
		HALL_POSITION_120	0x5555 _h	-0x8000 _h	0x7FFF _h
		HALL_POSITION_180	-0x8000 _h	-0x8000 _h	0x7FFF _h
RW	0x36 _h	HALL_POSITION_300_240			
		HALL_POSITION_240	-0x5556 _h	-0x8000 _h	0x7FFF _h
		HALL_POSITION_300	-0x2AAB _h	-0x8000 _h	0x7FFF _h
RW	0x37 _h	HALL_PHI_E_PHI_M_OFFSET			
		HALL_PHI_M_OFFSET	0x0 _h	-0x8000 _h	0x7FFF _h
		HALL_PHI_E_OFFSET	0x0 _h	-0x8000 _h	0x7FFF _h
RW	0x38 _h	HALL_DPHI_MAX			
		HALL_DPHI_MAX	0x2AAA _h	0x0 _h	0xFFFF _h
R	0x39 _h	HALL_PHI_E_INTERPOLATED_ PHI_E			
		HALL_PHI_E	0x0 _h	-0x8000 _h	0x7FFF _h
		HALL_PHI_E_INTERPOLATED	0x0 _h	-0x8000 _h	0x7FFF _h
R	0x3A _h	HALL_PHI_M			



		HALL_PHI_M	0x0 _h	-0x8000 _h	0x7FFF _h
RW	0x3B _h	AENC_DECODER_MODE			
		AENC_DECODER_MODE[0]	0x0 _h	0x0 _h	0x1 _h
		AENC_DECODER_MODE[12]	0x0 _h	0x0 _h	0x1 _h
RW	0x3C _h	AENC_DECODER_N_THRESHOLD			
		AENC_DECODER_N_THRESHOLD	0x0 _h	0x0 _h	0xFFFF _h
		AENC_DECODER_N_MASK	0x0 _h	-0x8000 _h	0x7FFF _h
R	0x3D _h	AENC_DECODER_PHI_A_RAW			
		AENC_DECODER_PHI_A_RAW	0x0 _h	-0x8000 _h	0x7FFF _h
RW	0x3E _h	AENC_DECODER_PHI_A_OFFSET			
		AENC_DECODER_PHI_A_OFFSET	0x0 _h	-0x8000 _h	0x7FFF _h
R	0x3F _h	AENC_DECODER_PHI_A			
		AENC_DECODER_PHI_A	0x0 _h	-0x80000000 _h	0x7FFFFFFF _h
RW	0x40 _h	AENC_DECODER_PPR			
		AENC_DECODER_PPR	0x1 _h	-0x8000 _h	0x7FFF _h
R	0x41 _h	AENC_DECODER_COUNT			
		AENC_DECODER_COUNT	0x0 _h	-0x80000000 _h	0x7FFFFFFF _h
RW	0x42 _h	AENC_DECODER_COUNT_N			
		AENC_DECODER_COUNT_N	0x0 _h	-0x80000000 _h	0x7FFFFFFF _h
RW	0x45 _h	AENC_DECODER_PHI_E_PHI_M_OFFSET			
		AENC_DECODER_PHI_M_OFFSET	0x0 _h	-0x8000 _h	0x7FFF _h



		AENC_DECODER_PHI_E_OFFSET	0x0 _h	-0x8000 _h	0x7FFF _h
R	0x46 _h	AENC_DECODER_PHI_E_PHI_M			
		AENC_DECODER_PHI_M	0x0 _h	-0x8000 _h	0x7FFF _h
		AENC_DECODER_PHI_E	0x0 _h	-0x8000 _h	0x7FFF _h
R	0x4B _h	PIDIN_VELOCITY_TARGET			
		PIDIN_VELOCITY_TARGET	0x0 _h	-0x8000000 _h	0x7FFFFFFF _h
R	0x4C _h	PIDIN_POSITION_TARGET			
		PIDIN_POSITION_TARGET	0x0 _h	-0x8000000 _h	0x7FFFFFFF _h
RW	0x4D _h	CONFIG_DATA			
		biquad_x_a_1	0x0 _h	-0x8000000 _h	0x7FFFFFFF _h
		biquad_x_a_2	0x0 _h	-0x8000000 _h	0x7FFFFFFF _h
		biquad_x_b_0	0x0 _h	-0x8000000 _h	0x7FFFFFFF _h
		biquad_x_b_1	0x0 _h	-0x8000000 _h	0x7FFFFFFF _h
		biquad_x_b_2	0x0 _h	-0x8000000 _h	0x7FFFFFFF _h
		biquad_x_enable	0x0 _h	0x0 _h	0x1 _h
		biquad_v_a_1	0x0 _h	-0x8000000 _h	0x7FFFFFFF _h
		biquad_v_a_2	0x0 _h	-0x8000000 _h	0x7FFFFFFF _h
		biquad_v_b_0	0x0 _h	-0x8000000 _h	0x7FFFFFFF _h
		biquad_v_b_1	0x0 _h	-0x8000000 _h	0x7FFFFFFF _h
		biquad_v_b_2	0x0 _h	-0x8000000 _h	0x7FFFFFFF _h
		biquad_v_enable	0x0 _h	0x0 _h	0x1 _h
		biquad_t_a_1	0x0 _h	-0x8000000 _h	0x7FFFFFFF _h
		biquad_t_a_2	0x0 _h	-0x8000000 _h	0x7FFFFFFF _h
		biquad_t_b_0	0x0 _h	-0x8000000 _h	0x7FFFFFFF _h
		biquad_t_b_1	0x0 _h	-0x8000000 _h	0x7FFFFFFF _h
		biquad_t_b_2	0x0 _h	-0x8000000 _h	0x7FFFFFFF _h
		biquad_t_enable	0x0 _h	0x0 _h	0x1 _h
		biquad_f_a_1	0x0 _h	-0x8000000 _h	0x7FFFFFFF _h
		biquad_f_a_2	0x0 _h	-0x8000000 _h	0x7FFFFFFF _h
		biquad_f_b_0	0x0 _h	-0x8000000 _h	0x7FFFFFFF _h



	biquad_f_b_1	0x0 _h	-0x80000000 _h	0x7FFFFFFF _h
	biquad_f_b_2	0x0 _h	-0x80000000 _h	0x7FFFFFFF _h
	biquad_f_enable	0x0 _h	0x0 _h	0x1 _h
	prbs_amplitude	0x0 _h	-0x80000000 _h	0x7FFFFFFF _h
	prbs_down_sampling_ratio	0x0 _h	-0x80000000 _h	0x7FFFFFFF _h
	feed_forward_velocity_gain	0x0 _h	-0x80000000 _h	0x7FFFFFFF _h
	feed_forward_velocity_filter_constant	0x0 _h	-0x80000000 _h	0x7FFFFFFF _h
	feed_forward_torque_gain	0x0 _h	-0x80000000 _h	0x7FFFFFFF _h
	feed_forward_torque_filter_constant	0x0 _h	-0x80000000 _h	0x7FFFFFFF _h
	VELOCITY_METER_PPTM_MIN_POS_DEV	0x0 _h	0x0 _h	0xFFFF _h
	ref_switch_config	0x0 _h	0x0 _h	0xFFFF _h
	Encoder_Init_hall_Enable	0x0 _h	0x0 _h	0x1 _h
	SINGLE_PIN_IF_CFG	0x0 _h	0x0 _h	0xFF _h
	SINGLE_PIN_IF_STATUS	0x0 _h	0x0 _h	0xFFFF _h
	SINGLE_PIN_IF_OFFSET	0x0 _h	0x0 _h	0xFFFF _h
	SINGLE_PIN_IF_SCALE	0x0 _h	-0x7FFF _h	0x7FFF _h
	CURRENT_P_nQ8.8_Q4.12	0x0 _h	0x0 _h	0x1 _h
	CURRENT_I_nQ8.8_Q4.12	0x0 _h	0x0 _h	0x1 _h
	VELOCITY_P_nQ8.8_Q4.12	0x0 _h	0x0 _h	0x1 _h
	VELOCITY_I_nQ8.8_Q4.12	0x0 _h	0x0 _h	0x1 _h
	POSITION_P_nQ8.8_Q4.12	0x0 _h	0x0 _h	0x1 _h
	POSITION_I_nQ8.8_Q4.12	0x0 _h	0x0 _h	0x1 _h
RW	0x4E _h CONFIG_ADDR			



		CONFIG_ADDR	0x0 _h	0x1 _h	0x3E _h	
RW	0x50 _h	VELOCITY_SELECTION				
		VELOCITY_SELECTION	0x0 _h	0x0 _h	0xC _h	
		VELOCITY_METER_SELECTION	0x0 _h	0x0 _h	0x1 _h	
RW	0x51 _h	POSITION_SELECTION				
		POSITION_SELECTION	0x0 _h	0x0 _h	0xC _h	
RW	0x52 _h	PHI_E_SELECTION				
		PHI_E_SELECTION	0x0 _h	0x0 _h	0x7 _h	
R	0x53 _h	PHI_E				
		PHI_E	0x0 _h	-0x8000 _h	0x7FFF _h	
RW	0x54 _h	PID_FLUX_P_FLUX_I				
		PID_FLUX_I	0x0 _h	0x0 _h	0x7FFF _h	
		PID_FLUX_P	0x0 _h	0x0 _h	0x7FFF _h	
RW	0x56 _h	PID_TORQUE_P_TORQUE_I				
		PID_TORQUE_I	0x0 _h	0x0 _h	0x7FFF _h	
		PID_TORQUE_P	0x0 _h	0x0 _h	0x7FFF _h	
RW	0x58 _h	PID_VELOCITY_P_VELOCITY_I				
		PID_VELOCITY_I	0x0 _h	0x0 _h	0x7FFF _h	
		PID_VELOCITY_P	0x0 _h	0x0 _h	0x7FFF _h	
RW	0x5A _h	PID_POSITION_P_POSITION_I				
		PID_POSITION_I	0x0 _h	0x0 _h	0x7FFF _h	
		PID_POSITION_P	0x0 _h	0x0 _h	0x7FFF _h	
RW	0x5D _h	PIDOUT_UQ_UD_LIMITS				
		PIDOUT_UQ_UD_LIMITS	0x5A81 _h	0x0 _h	0x7FFF _h	
RW	0x5E _h	PID_TORQUE_FLUX_LIMITS				
		PID_TORQUE_FLUX_LIMITS	0x7FFF _h	0x0 _h	0x7FFF _h	
RW	0x5F _h	PID_ACCELERATION_LIMIT				



		PID_ACCELERATION_LIMIT	0x7FFFFFFF _h	0x0 _h	0xFFFFFFFF _h	
RW	0x60 _h	PID_VELOCITY_LIMIT				
		PID_VELOCITY_LIMIT	0x7FFFFFFF _h	0x0 _h	0xFFFFFFFF _h	
RW	0x61 _h	PID_POSITION_LIMIT_LOW				
		PID_POSITION_LIMIT_LOW	-0x7FFFFFFF _h	-0x80000000 _h	0x7FFFFFFF _h	
RW	0x62 _h	PID_POSITION_LIMIT_HIGH				
		PID_POSITION_LIMIT_HIGH	0x7FFFFFFF _h	-0x80000000 _h	0x7FFFFFFF _h	
RW	0x63 _h	MODE_RAMP_MODE_MOTION				
		MODE_MOTION	0x0 _h	0x0 _h	0xF _h	
		MODE_RAMP	0x0 _h	0x0 _h	0x7 _h	
		MODE_FF	0x0 _h	0x0 _h	0x2 _h	
		MODE_PID_SMPL	0x0 _h	0x0 _h	0x7F _h	
		MODE_PID_TYPE	0x0 _h	0x0 _h	0x1 _h	
RW	0x64 _h	PID_TORQUE_FLUX_TARGET				
		PID_FLUX_TARGET	0x0 _h	-0x8000 _h	0x7FFF _h	
		PID_TORQUE_TARGET	0x0 _h	-0x8000 _h	0x7FFF _h	
RW	0x65 _h	PID_TORQUE_FLUX_OFFSET				
		PID_FLUX_OFFSET	0x0 _h	-0x8000 _h	0x7FFF _h	
		PID_TORQUE_OFFSET	0x0 _h	-0x8000 _h	0x7FFF _h	
RW	0x66 _h	PID_VELOCITY_TARGET				
		PID_VELOCITY_TARGET	0x0 _h	-0x80000000 _h	0x7FFFFFFF _h	
RW	0x67 _h	PID_VELOCITY_OFFSET				
		PID_VELOCITY_OFFSET	0x0 _h	-0x80000000 _h	0x7FFFFFFF _h	
RW	0x68 _h	PID_POSITION_TARGET				



		PID_POSITION_TARGET	0x0 _h	-0x8000000 _h	0x7FFFFFF _h
R	0x69 _h	PID_TORQUE_FLUX_ACTUAL			
		PID_FLUX_ACTUAL	0x0 _h	-0x8000 _h	0x7FFF _h
		PID_TORQUE_ACTUAL	0x0 _h	-0x8000 _h	0x7FFF _h
R	0x6A _h	PID_VELOCITY_ACTUAL			
		PID_VELOCITY_ACTUAL	0x0 _h	-0x8000000 _h	0x7FFFFFF _h
RW	0x6B _h	PID_POSITION_ACTUAL			
		PID_POSITION_ACTUAL	0x0 _h	-0x8000000 _h	0x7FFFFFF _h
R	0x6C _h	PID_ERROR_DATA			
		PID_TORQUE_ERROR	0x0 _h	-0x8000000 _h	0x7FFFFFF _h
		PID_FLUX_ERROR	0x0 _h	-0x8000000 _h	0x7FFFFFF _h
		PID_VELOCITY_ERROR	0x0 _h	-0x8000000 _h	0x7FFFFFF _h
		PID_POSITION_ERROR	0x0 _h	-0x8000000 _h	0x7FFFFFF _h
		PID_TORQUE_ERROR_SUM	0x0 _h	-0x8000000 _h	0x7FFFFFF _h
		PID_FLUX_ERROR_SUM	0x0 _h	-0x8000000 _h	0x7FFFFFF _h
		PID_VELOCITY_ERROR_SUM	0x0 _h	-0x8000000 _h	0x7FFFFFF _h
		PID_POSITION_ERROR_SUM	0x0 _h	-0x8000000 _h	0x7FFFFFF _h
RW	0x6D _h	PID_ERROR_ADDR			
		PID_ERROR_ADDR	0x0 _h	0x0 _h	0x7 _h
RW	0x6E _h	INTERIM_DATA			
		PIDIN_TARGET_TORQUE	0x0 _h	-0x8000000 _h	0x7FFFFFF _h
		PIDIN_TARGET_FLUX	0x0 _h	-0x8000000 _h	0x7FFFFFF _h
		PIDIN_TARGET_VELOCITY	0x0 _h	-0x8000000 _h	0x7FFFFFF _h
		PIDIN_TARGET_POSITION	0x0 _h	-0x8000000 _h	0x7FFFFFF _h



PIDOUT_TARGET_TORQUE	0x0 _h	-0x8000000 _h	0x7FFFFFFF _h
PIDOUT_TARGET_FLUX	0x0 _h	-0x8000000 _h	0x7FFFFFFF _h
PIDOUT_TARGET_VELOCITY	0x0 _h	-0x8000000 _h	0x7FFFFFFF _h
PIDOUT_TARGET_POSITION	0x0 _h	-0x8000000 _h	0x7FFFFFFF _h
FOC_IUX	0x0 _h	-0x8000 _h	0x7FFF _h
FOC_IWY	0x0 _h	-0x8000 _h	0x7FFF _h
FOC_IV	0x0 _h	-0x8000 _h	0x7FFF _h
FOC_IA	0x0 _h	-0x8000 _h	0x7FFF _h
FOC_IB	0x0 _h	-0x8000 _h	0x7FFF _h
FOC_ID	0x0 _h	-0x8000 _h	0x7FFF _h
FOC_IQ	0x0 _h	-0x8000 _h	0x7FFF _h
FOC_UD	0x0 _h	-0x8000 _h	0x7FFF _h
FOC_UQ	0x0 _h	-0x8000 _h	0x7FFF _h
FOC_UD_LIMITED	0x0 _h	-0x8000 _h	0x7FFF _h
FOC_UQ_LIMITED	0x0 _h	-0x8000 _h	0x7FFF _h
FOC_UA	0x0 _h	-0x8000 _h	0x7FFF _h
FOC_UB	0x0 _h	-0x8000 _h	0x7FFF _h
FOC_UUX	0x0 _h	-0x8000 _h	0x7FFF _h
FOC_UWY	0x0 _h	-0x8000 _h	0x7FFF _h
FOC_UV	0x0 _h	-0x8000 _h	0x7FFF _h
PWM_UX	0x0 _h	-0x8000 _h	0x7FFF _h
PWM_WY	0x0 _h	-0x8000 _h	0x7FFF _h
PWM_V	0x0 _h	-0x8000 _h	0x7FFF _h
ADC_I_0	0x0 _h	-0x8000 _h	0x7FFF _h
ADC_I_1	0x0 _h	-0x8000 _h	0x7FFF _h
PID_FLUX_ACTUAL_DIV256	0x0 _h	-0x80 _h	0x7F _h
PID_TORQUE_ACTUAL_DIV256	0x0 _h	-0x80 _h	0x7F _h
PID_FLUX_TARGET_DIV256	0x0 _h	-0x80 _h	0x7F _h
PID_TORQUE_TARGET_DIV256	0x0 _h	-0x80 _h	0x7F _h



PID_TORQUE_ ACTUAL	0x0 _h	-0x8000 _h	0x7FFF _h
PID_TORQUE_ TARGET	0x0 _h	-0x8000 _h	0x7FFF _h
PID_FLUX_ACTUAL	0x0 _h	-0x8000 _h	0x7FFF _h
PID_FLUX_TARGET	0x0 _h	-0x8000 _h	0x7FFF _h
PID_VELOCITY_ ACTUAL_DIV256	0x0 _h	-0x8000 _h	0x7FFF _h
PID_VELOCITY_ TARGET_DIV256	0x0 _h	-0x8000 _h	0x7FFF _h
PID_VELOCITY_ ACTUAL_LSB	0x0 _h	-0x8000 _h	0x7FFF _h
PID_VELOCITY_ TARGET_LSB	0x0 _h	-0x8000 _h	0x7FFF _h
PID_POSITION_ ACTUAL_DIV256	0x0 _h	-0x8000 _h	0x7FFF _h
PID_POSITION_ TARGET_DIV256	0x0 _h	-0x8000 _h	0x7FFF _h
PID_POSITION_ ACTUAL_LSB	0x0 _h	-0x8000 _h	0x7FFF _h
PID_POSITION_ TARGET_LSB	0x0 _h	-0x8000 _h	0x7FFF _h
FF_VELOCITY	0x0 _h	-0x80000000 _h	0x7FFFFFFF _h
FF_TORQUE	0x0 _h	-0x8000 _h	0x7FFF _h
ACTUAL_VELOCITY_ PPTM	0x0 _h	-0x80000000 _h	0x7FFFFFFF _h
REF_SWITCH_STATUS	0x0 _h	0x0 _h	0xFFFF _h
HOME_POSITION	0x0 _h	-0x80000000 _h	0x7FFFFFFF _h
LEFT_POSITION	0x0 _h	-0x80000000 _h	0x7FFFFFFF _h
RIGHT_POSITION	0x0 _h	-0x80000000 _h	0x7FFFFFFF _h
ENC_INIT_HALL_ STATUS	0x0 _h	0x0 _h	0xFFFF _h
ENC_INIT_HALL_PHI_ E_ABN_OFFSET	0x0 _h	0x0 _h	0xFFFF _h
ENC_INIT_HALL_PHI_ E_AENC_OFFSET	0x0 _h	0x0 _h	0xFFFF _h
ENC_INIT_HALL_PHI_ A_AENC_OFFSET	0x0 _h	0x0 _h	0xFFFF _h



		SINGLE_PIN_IF_TARGET_TORQUE	0x0 _h	-0x8000 _h	0x8000 _h
		SINGLE_PIN_IF_PWM_DUTY_CYCLE	0x0 _h	-0x8000 _h	0x8000 _h
		SINGLE_PIN_IF_TARGET_VELOCITY	0x0 _h	-0x80000000 _h	0x7FFFFFFF _h
		SINGLE_PIN_IF_TARGET_POSITION	0x0 _h	-0x80000000 _h	0x7FFFFFFF _h
RW	0x6F _h	INTERIM_ADDR			
		INTERIM_ADDR	0x0 _h	0x0 _h	0xD7 _h
RW	0x75 _h	ADC_VM_LIMITS			
		ADC_VM_LIMIT_LOW	0xFFFF _h	0x0 _h	0xFFFF _h
		ADC_VM_LIMIT_HIGH	0xFFFF _h	0x0 _h	0xFFFF _h
R	0x76 _h	TMC4671_INPUTS_RAW			
		A of ABN_RAW	0x0 _h	0x0 _h	0x1 _h
		B of ABN_RAW	0x0 _h	0x0 _h	0x1 _h
		N of ABN_RAW	0x0 _h	0x0 _h	0x1 _h
		-	0x0 _h	0x0 _h	0x1 _h
		A of ABN_2_RAW	0x0 _h	0x0 _h	0x1 _h
		B of ABN_2_RAW	0x0 _h	0x0 _h	0x1 _h
		N of ABN_2_RAW	0x0 _h	0x0 _h	0x1 _h
		-	0x0 _h	0x0 _h	0x1 _h
		HALL_UX of HALL_RAW	0x0 _h	0x0 _h	0x1 _h
		HALL_V of HALL_RAW	0x0 _h	0x0 _h	0x1 _h
		HALL_WY of HALL_RAW	0x0 _h	0x0 _h	0x1 _h
		-	0x0 _h	0x0 _h	0x1 _h
		REF_SW_R_RAW	0x0 _h	0x0 _h	0x1 _h
		REF_SW_H_RAW	0x0 _h	0x0 _h	0x1 _h
		REF_SW_L_RAW	0x0 _h	0x0 _h	0x1 _h
		ENABLE_IN_RAW	0x0 _h	0x0 _h	0x1 _h
		STP of DIRSTP_RAW	0x0 _h	0x0 _h	0x1 _h
		DIR of DIRSTP_RAW	0x0 _h	0x0 _h	0x1 _h
		PWM_IN_RAW	0x0 _h	0x0 _h	0x1 _h
		-	0x0 _h	0x0 _h	0x1 _h



		HALL_UX_FILT	0x0 _h	0x0 _h	0x1 _h
		HALL_V_FILT	0x0 _h	0x0 _h	0x1 _h
		HALL_WY_FILT	0x0 _h	0x0 _h	0x1 _h
		-	0x0 _h	0x0 _h	0x1 _h
		-	0x0 _h	0x0 _h	0x1 _h
		-	0x0 _h	0x0 _h	0x1 _h
		-	0x0 _h	0x0 _h	0x1 _h
		-	0x0 _h	0x0 _h	0x1 _h
		PWM_IDLE_L_RAW	0x0 _h	0x0 _h	0x1 _h
		PWM_IDLE_H_RAW	0x0 _h	0x0 _h	0x1 _h
		-	0x0 _h	0x0 _h	0x1 _h
		-	0x0 _h	0x0 _h	0x1 _h
R	0x77 _h	TMC4671_OUTPUTS_RAW			
		TMC4671_OUTPUTS_RAW[0]	0x0 _h	0x0 _h	0x1 _h
		TMC4671_OUTPUTS_RAW[1]	0x0 _h	0x0 _h	0x1 _h
		TMC4671_OUTPUTS_RAW[2]	0x0 _h	0x0 _h	0x1 _h
		TMC4671_OUTPUTS_RAW[3]	0x0 _h	0x0 _h	0x1 _h
		TMC4671_OUTPUTS_RAW[4]	0x0 _h	0x0 _h	0x1 _h
		TMC4671_OUTPUTS_RAW[5]	0x0 _h	0x0 _h	0x1 _h
		TMC4671_OUTPUTS_RAW[6]	0x0 _h	0x0 _h	0x1 _h
		TMC4671_OUTPUTS_RAW[7]	0x0 _h	0x0 _h	0x1 _h
RW	0x78 _h	STEP_WIDTH			
		STEP_WIDTH	0x0 _h	-0x80000000 _h	0x7FFFFFFF _h
RW	0x79 _h	UART_BPS			
		UART_BPS	0x00009600 _h	0x0 _h	0xFFFFF _h
RW	0x7B _h	GPIO_dsADCI_CONFIG			
		GPIO_dsADCI_CONFIG[0]	0x0 _h	0x0 _h	0x1 _h
		GPIO_dsADCI_CONFIG[1]	0x0 _h	0x0 _h	0x1 _h



		GPIO_dsADCI_CONFIG[2]	0x0 _h	0x0 _h	0x1 _h
		GPIO_dsADCI_CONFIG[3]	0x0 _h	0x0 _h	0x1 _h
		GPIO_dsADCI_CONFIG[4]	0x0 _h	0x0 _h	0x1 _h
		GPIO_dsADCI_CONFIG[5]	0x0 _h	0x0 _h	0x1 _h
		GPIO_dsADCI_CONFIG[6]	0x0 _h	0x0 _h	0x1 _h
		GPO	0x0 _h	0x0 _h	0xFF _h
		GPI	0x0 _h	0x0 _h	0xFF _h
RW	0x7C _h	STATUS_FLAGS			
		STATUS_FLAGS[0]	0x0 _h	0x0 _h	0x1 _h
		STATUS_FLAGS[1]	0x0 _h	0x0 _h	0x1 _h
		STATUS_FLAGS[2]	0x0 _h	0x0 _h	0x1 _h
		STATUS_FLAGS[3]	0x0 _h	0x0 _h	0x1 _h
		STATUS_FLAGS[4]	0x0 _h	0x0 _h	0x1 _h
		STATUS_FLAGS[5]	0x0 _h	0x0 _h	0x1 _h
		STATUS_FLAGS[6]	0x0 _h	0x0 _h	0x1 _h
		STATUS_FLAGS[7]	0x0 _h	0x0 _h	0x1 _h
		STATUS_FLAGS[8]	0x0 _h	0x0 _h	0x1 _h
		STATUS_FLAGS[9]	0x0 _h	0x0 _h	0x1 _h
		STATUS_FLAGS[10]	0x0 _h	0x0 _h	0x1 _h
		STATUS_FLAGS[11]	0x0 _h	0x0 _h	0x1 _h
		STATUS_FLAGS[12]	0x0 _h	0x0 _h	0x1 _h
		STATUS_FLAGS[13]	0x0 _h	0x0 _h	0x1 _h
		STATUS_FLAGS[14]	0x0 _h	0x0 _h	0x1 _h
		STATUS_FLAGS[15]	0x0 _h	0x0 _h	0x1 _h
		STATUS_FLAGS[16]	0x0 _h	0x0 _h	0x1 _h
		STATUS_FLAGS[17]	0x0 _h	0x0 _h	0x1 _h
		STATUS_FLAGS[18]	0x0 _h	0x0 _h	0x1 _h
		STATUS_FLAGS[19]	0x0 _h	0x0 _h	0x1 _h
		STATUS_FLAGS[20]	0x0 _h	0x0 _h	0x1 _h
		STATUS_FLAGS[21]	0x0 _h	0x0 _h	0x1 _h
		STATUS_FLAGS[22]	0x0 _h	0x0 _h	0x1 _h
		STATUS_FLAGS[23]	0x0 _h	0x0 _h	0x1 _h
		STATUS_FLAGS[24]	0x0 _h	0x0 _h	0x1 _h



		STATUS_FLAGS[25]	0x0 _h	0x0 _h	0x1 _h	
		STATUS_FLAGS[26]	0x0 _h	0x0 _h	0x1 _h	
		STATUS_FLAGS[27]	0x0 _h	0x0 _h	0x1 _h	
		STATUS_FLAGS[28]	0x0 _h	0x0 _h	0x1 _h	
		STATUS_FLAGS[29]	0x0 _h	0x0 _h	0x1 _h	
		STATUS_FLAGS[30]	0x0 _h	0x0 _h	0x1 _h	
		STATUS_FLAGS[31]	0x0 _h	0x0 _h	0x1 _h	
RW	0x7D _h	STATUS_MASK				
		WARNING_MASK	0x0 _h	0x0 _h	0xFFFFFFFF _h	



8 Pinning

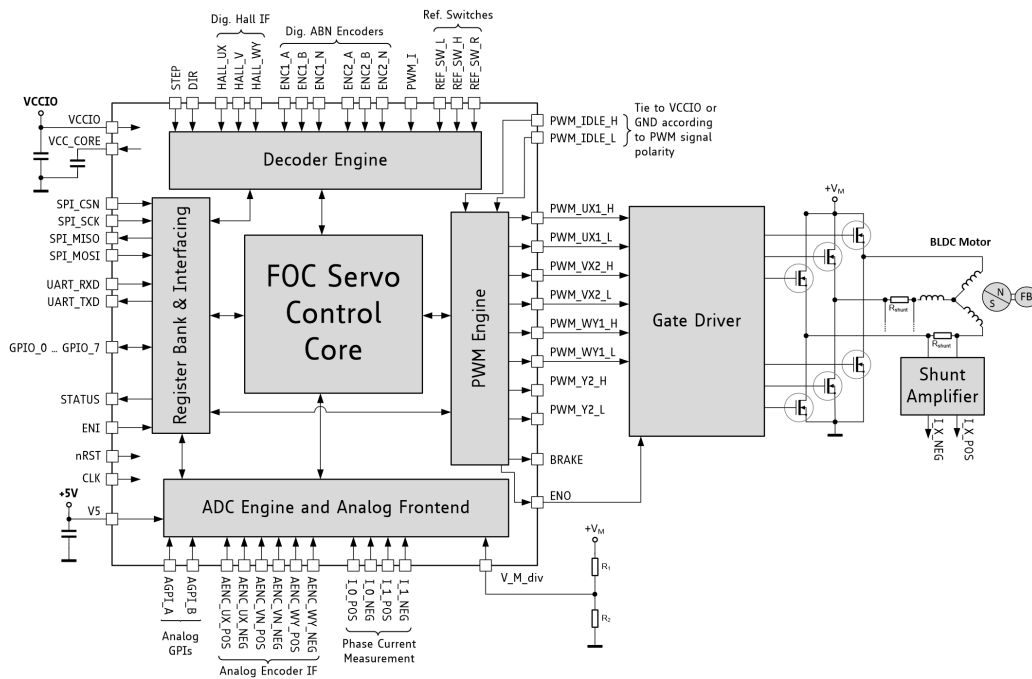

Figure 39: TMC4671 Pinout with 3 phase Power stage and BLDC Motor

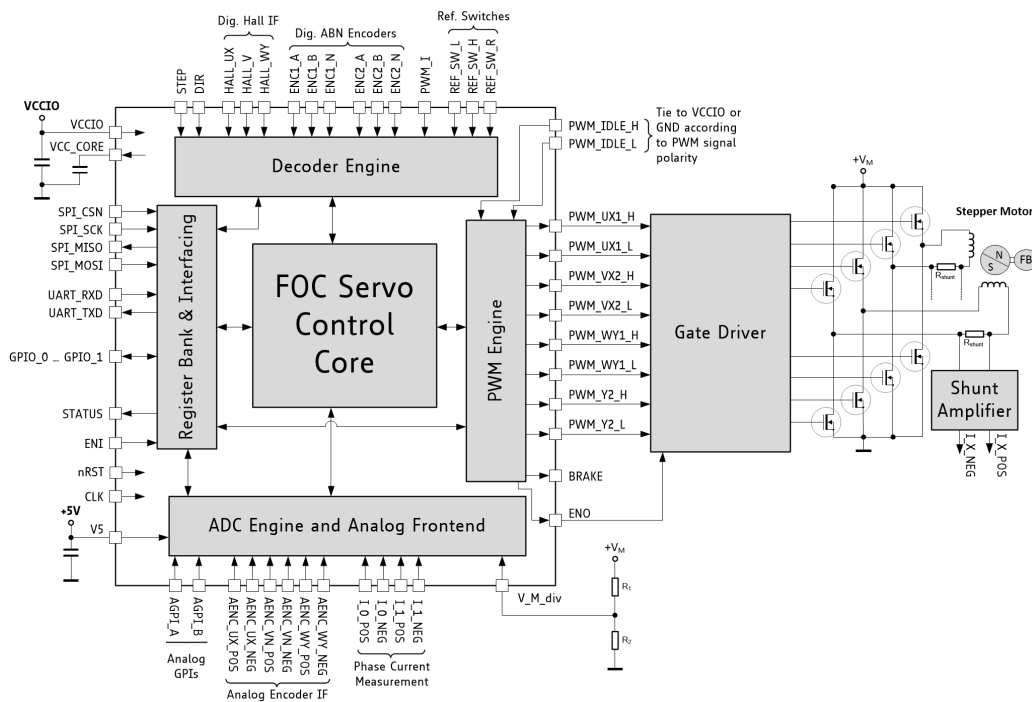

Figure 40: TMC4671 Pinout with Stepper Motor



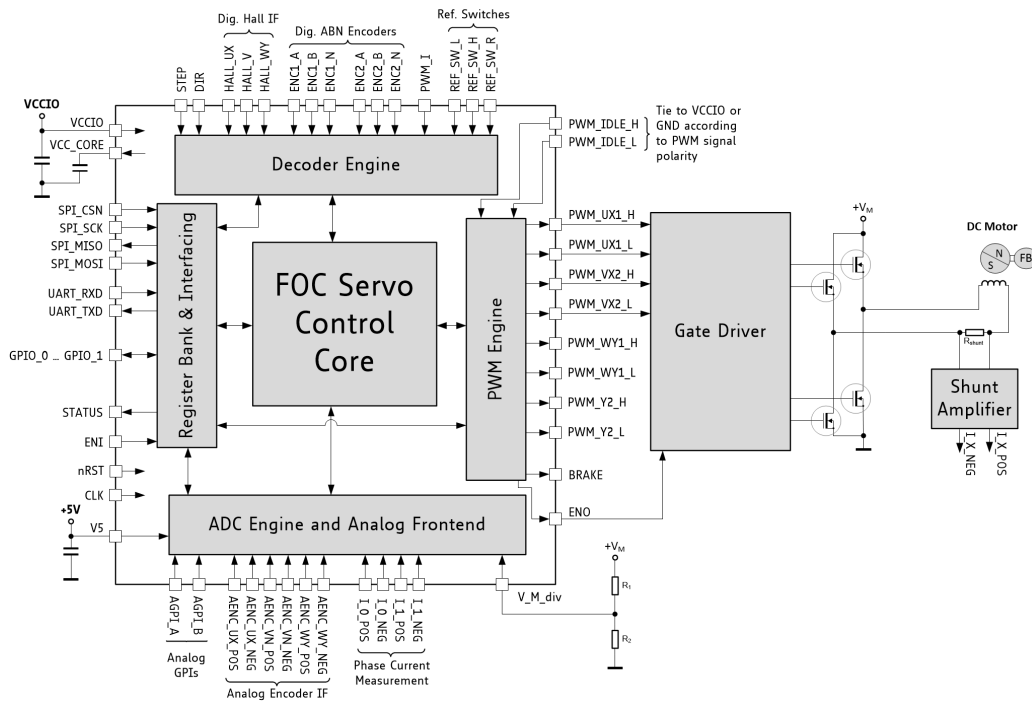

Figure 41: TMC4671 Pinout with DC Motor or Voice Coil

Info

All power supply pins (VCC, VCC_CORE) must be connected.

All ground pins (GND, GNDA, ...) must be connected.

Analog inputs (AI) are 5V single ended or differential inputs (Input range: GNDA to V5). Use voltage dividers or operational amplifiers to scale down higher input voltages.

Digital inputs (I) resp. (IO) are 3.3V single ended inputs.

IO	Description
AI	analog input, 3.3V
I	digital input, 3.3V
IO	digital input or digital output, direction programmable, 3.3V
O	digital output, 3.3V

Table 31: Pin Type Definition



9 TMC4671 Pin Table

Name	Pin	IO	Description
nRST	50	I	active low reset input
CLK	51	I	clock input; needs to be 25 MHz for correct timing
TEST	54	I	TEST input, must be connected to GND
ENI	55	I	enable input; If high, controllers and PWM are enabled
ENO	32	O	enable output; feeds through ENI when CLK is applied and IC is not in reset condition
STATUS	12	O	output for interrupt of CPU (Warning & Status Change)
SPI_nSCS	6	I	SPI active low chip select input
SPI_SCK	7	I	SPI clock input
SPI_MOSI	8	I	SPI master out slave input
SPI_MISO	9	O	SPI master in slave output, high impedance, when SPI_nSCS = '1'
UART_RXD	10	I	UART receive data RxD for in-system-user communication channel
UART_TXD	11	O	UART transmit data TXD for in-system-user communication channel
PWM_I	58	I	PWM input for target value generation
DIR	56	I	direction input of step-direction interface
STP	57	I	step pulse input for step-direction interface
HALL_UX	38	I	digital hall input H1 for 3-phase (U) or 2-phase (X)
HALL_V	37	I	digital hall input H2 for 3-phase (V)
HALL_WY	36	I	digital hall input H3 for 3-phase (W) or 2-phase (Y)
ENC_A	35	I	A input of incremental encoder
ENC_B	34	I	B input of incremental encoder
ENC_N	33	I	N input of incremental encoder
ENC2_A	64	I	A input of incremental encoder
ENC2_B	65	I	B input of incremental encoder
ENC2_N	66	I	N input of incremental encoder
REF_L	67	I	Left (L) reference switch
REF_H	68	I	Home (H) reference switch
REF_R	69	I	Right (R) reference switch
ADC_I0_POS	16	AI	pos. input for phase current signal measurement I0 (I_U, I_X)



Name	Pin	IO	Description
ADC_I0_NEG	17	AI	neg. input for phase current signal measurement I0 (I_U, I_X)
ADC_I1_POS	18	AI	pos. input for phase current signal measurement I1 (I_V, I_W, I_Y)
ADC_I1_NEG	19	AI	neg. input for phase current signal measurement I1 (I_V, I_W, I_Y)
ADC_VM	20	AI	analog input for motor supply voltage divider (VM) measurement
AGPI_A	21	AI	analog general purpose input A (analog GPI)
AGPI_B	22	AI	analog general purpose input B (analog GPI)
AENC_UX_POS	25	AI	pos. analog input for Hall or analog encoder signal, 3-phase (U) or 2-phase (X (cos))
AENC_UX_NEG	26	AI	neg. analog input for Hall or analog encoder signal, 3-phase (U) or 2-phase (X (cos))
AENC_VN_POS	27	AI	pos. analog input for Hall or analog encoder signal, 3-phase (V) or 2-phase (N)
AENC_VN_NEG	28	AI	neg. analog input for Hall or analog encoder signal, 3-phase (V) or 2-phase (N)
AENC_WY_POS	29	AI	pos. analog input for Hall or analog encoder signal, 3-phase (W) or 2-phase (Y (sin))
AENC_WY_NEG	30	AI	neg. analog input for Hall or analog encoder signal, 3-phase (W) or 2-phase (Y (sin))
GPIO0 / ADC_I0_MCD	70	IO	GPIO or $\Delta\Sigma$ -Demodulator clock input MCLKI, clock output MCLKO, or single bit DAC output MDAC for ADC_I_0
GPIO1 / ADC_I1_MCD	71	IO	GPIO or $\Delta\Sigma$ -Demodulator clock input MCLKI, clock output MCLKO, or single bit DAC output MDAC for ADC_I_1
GPIO2 / ADC_VM_MCD	74	IO	GPIO or $\Delta\Sigma$ -Demodulator clock input MCLKI, clock output MCLKO, or single bit DAC output MDAC for ADC_VM_MCD
GPIO3 / AGPI_A_MCD / DBGSPI_nSCS	75	IO	GPIO or $\Delta\Sigma$ -Demodulator clock input MCLKI, clock output MCLKO, or single bit DAC output MDAC for AENC_UX_MCD, SPI debug port pin DBGSPI_nSCS
GPIO4 / AGPI_B_MCD / DBGSPI_SCK	76	IO	GPIO or $\Delta\Sigma$ -Demodulator clock input MCLKI, clock output MCLKO, or single bit DAC output MDAC for AENC_VN_MCD, SPI debug port pin DBGSPI_SCK
GPIO5 / AENC_UX_MCD / DBGSPI_MOSI	1	IO	GPIO or $\Delta\Sigma$ -Demodulator clock input MCLKI, clock output MCLKO, or single bit DAC output MDAC for AENC_WY_MCD, SPI debug port pin DBGSPI_MOSI



Name	Pin	IO	Description
GPIO6 / AENC_VN_MCD / DBGSPI_MISO	4	IO	GPIO or $\Delta\Sigma$ -Demodulator clock input MCLKI, clock output MCLKO, or single bit DAC output MDAC for AGPI_A_MCD, SPI debug port pin DBGSPI_MISO
GPIO7 / AENC_WY_MCD / DBGSPI_TRG	5	IO	GPIO or $\Delta\Sigma$ -Demodulator clock input MCLKI, clock output MCLKO, or single bit DAC output MDAC for AGPI_B_MCD, SPI debug port pin DBGSPI_TRG
PWM_IDLE_H	59	I	idle level of high side gate control signals (not used)
PWM_IDLE_L	60	I	idle level of low side gate control signals (not used)
PWM_UX1_H	39	O	high side gate control output U (3-phase) resp. X1 (2-phase)
PWM_UX1_L	40	O	low side gate control output U (3-phase) resp. X1 (2-phase)
PWM_VX2_H	41	O	high side gate control output V (3-phase) resp. X2 (2-phase)
PWM_VX2_L	42	O	low side gate control output V (3-phase) resp. X2 (2-phase)
PWM_WY1_H	46	O	high side gate control output W (3-phase) resp. Y1 (2-phase)
PWM_WY1_L	47	O	low side gate control output W (3-phase) resp. Y1 (2-phase)
PWM_Y2_H	48	O	high side gate control output Y2 (2-phase only)
PWM_Y2_L	49	O	low side gate control output Y2 (2-phase only)
BRAKE	31	O	brake chopper control output signal

Table 32: Functional Pin Description

Feedback input pins that are not needed in target application can be left open or tied to GND.



Name	Pin	IO	Description
VCCIO1	2	3.3V	digital IO supply voltage; use 100 nF decoupling capacitor
VCCIO2	13	3.3V	digital IO supply voltage; use 100 nF decoupling capacitor
VCCIO3	43	3.3V	digital IO supply voltage; use 100 nF decoupling capacitor
VCCIO4	52	3.3V	digital IO supply voltage; use 100 nF decoupling capacitor
VCCIO5	61	3.3V	digital IO supply voltage; use 100 nF decoupling capacitor
VCCIO6	72	3.3V	digital IO supply voltage; use 100 nF decoupling capacitor
GNDIO1	3	0V	digital IO ground
GNDIO2	14	0V	digital IO ground
GNDIO3	44	0V	digital IO ground
GNDIO4	53	0V	digital IO ground
GNDIO5	62	0V	digital IO ground
GNDIO6	73	0V	digital IO ground
VCCCORE1	15	1.8V	digital core supply voltage output; use 100 nF decoupling capacitor
VCCCORE2	45	1.8V	digital core supply voltage output; use 100 nF decoupling capacitor
VCCCORE3	63	1.8V	digital core supply voltage output; use 100 nF decoupling capacitor
V5	23	5V	analog reference voltage
GND A	24	0V	analog reference ground
GNDPAD	-	0V	bottom ground pad

Table 33: Supply Voltage Pins and Ground Pins



10 Electrical Characteristics

10.1 Absolute Maximum Ratings

The maximum ratings may not be exceeded under any circumstances. Operating the circuit at or near more than one maximum rating at a time for extended periods shall be avoided by application design.

Parameter	Symbol	Min	Max	Unit
Digital I/O supply voltage	VCCIO		3.6	V
Logic input voltage	VI		3.6	V
Maximum current drawn on VCCIO with no load on pins	I_IO		70	mA
Maximum current drawn on VCCIO with no load on pins and clock off	I_IO_0Hz		3	mA
Maximum current drawn on V5 at fCLK = 25MHz	I_V5		25	mA
Maximum current to / from digital pins and analog low voltage I/Os	IIO		10	mA
Junction temperature	TJ	-40	125	°C
Storage temperature	TSTG	-55	150	°C
ESD-Protection for interface pins (Human body model, HBM)	VESDAP		2	kV
ESD-Protection for handling (Human body model, HBM)	VESD1		2	kV
ADC input voltage	VAI	0	5	V

Table 34: Absolute Maximum Ratings

VCCCORE is generated internally from VCCIO and shall not be overpowered by external supply.

10.2 Electrical Characteristics

10.2.1 Operational Range

Parameter	Symbol	Min	Max	Unit
Junction temperature	TJ	-40	125	°C
Digital I/O 3.3V supply voltage	VIO3V	3.15	3.45	V
Core supply voltage	VCC_CORE	1.65	1.95	V

Table 35: Operational Range

The $\Delta\Sigma$ ADCs can operate in differential or single ended mode. In differential mode the differential input voltage range must be in between -2.5V and +2.5V. However, it is recommended to use the input voltage range from -1.25V to 1.25V, due to non-linearity of $\Delta\Sigma$ ADCs. In Single ended mode the operational input range of the positive input channel should be between 0V and 2.5V. Recommended maximum input voltage is 1.25V. ADCs have



10.2.2 DC Characteristics

DC characteristics contain the spread of values guaranteed within the specified supply voltage range unless otherwise specified. Typical values represent the average value of all parts measured at +25 °C. Temperature variation also causes stray to some values. A device with typical values will not leave Min/Max range within the full temperature range.

Parameter	Symbol	Condition	Min	Typ	Max	Unit
Input voltage low level	VINL	VCCIO = 3.3V	-0.3		0.8	V
Input voltage high level	VINH	VCCIO = 3.3V	2.3		3.6	V
Input with pull-down		VIN = 3.3V	5	30	110	μ A
Input with pull-up		VIN = 0V	-110	-30	-5	μ A
Input low current		VIN = 0V	-10		10	μ A
Input high current		VIN = VCCIO	-10		10	μ A
Output voltage low level	VOUTL	VCCIO = 3.3V	0.4			V
Output voltage high level	VOUTH	VCCIO = 3.3V	2.64			V
Output driver strength standard	IOUT_DRV		4			mA
Input impedance of Analog Input	R_ADC	TJ = 25°C	85	100	115	k Ω

Table 36: DC Characteristics

All I/O lines include Schmitt-Trigger inputs to enhance noise margin.



11 Sample Circuits

Please consider electrical characteristics while designing electrical circuitry. Most Sample Circuits in this chapter were taken from the evaluation board for the TMC4671 (TMC4671-EVAL).

11.1 Supply Pins

Please provide VCCIO and V5 to the TMC4671. VCC_CORE is internally generated and needs just an external decoupling capacitor. Place one 100nF decoupling capacitor at every supply pin. Table 37 lists additional needed decoupling capacitors.

Pin Name	Supply Voltage	Additional Cap.
V5	5V	4.7uF
VCCIO	3.3V	4.7uF & 470nF
VCCCORE	1.8V	none

Table 37: Additional decoupling capacitors for supply voltages

11.2 Clock and Reset Circuitry

The TMC4671 needs an external oscillator for correct operation at 25 MHz. Lower frequency results in respective scaling of timings. Higher frequency is not supported. The internally generated active low reset can be externally overwritten. If users want to toggle the reset, a pulse length of at least 500 ns is recommended. When not used, please apply a 10k Pull up resistor and make sure all supply voltages are stable.

11.3 Digital Encoder, Hall Sensor Interface and Reference Switches

Digital encoders, Hall sensors and reference switches usually operate on a supply voltage of 5V. As the TMC4671 is usually operated at a VCCIO Voltage of 3.3V, a protection circuit for the TMC4671 input pin is needed. In fig. 42 a sample circuit for the ENC_A signal is shown, which can be reused for all encoder and Hall signals as well as for reference switch signals. Parametrization of the components is given in table 38 for different operations.

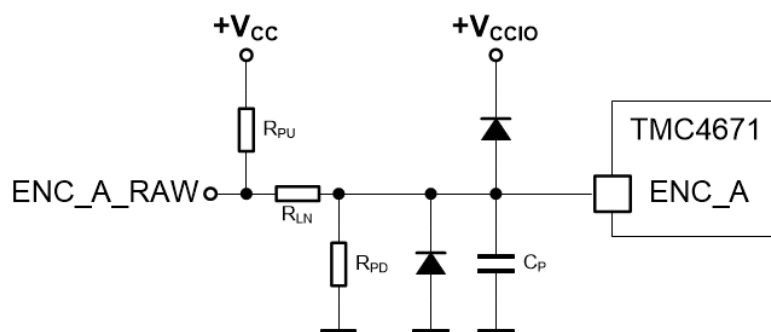

Figure 42: Sample Circuit for Interfacing of an Encoder Signal



Application	R_{PU}	R_{PD}	R_{LN}	C_P
5 V Encoder signal	4K7	n.c.	100R	100pF

Table 38: Reference Values for circuitry components

The raw signal (ENC_A_RAW) is divided by a voltage divider and filtered by a low-pass filter. A pull up resistor is applied for open collector encoder output signals. Diodes protect the input pin (ENC_A) against over- and undervoltage. The cutoff-frequency of the low-pass is:

$$f_c = \frac{1}{2\pi R_{PD}C_P} \quad (50)$$

11.4 Analog Frontend

Analog Encoders are encoding the motor position into sinusoidal signals. These signals need to be digitalized by the TMC4671 in order to determine the rotor position. The input voltage range depends on V5 input, which is usually 5V and GNDA (usually 0V). Due to nonlinearity issues of the ADC near input limits, an ADC input value from 1V to 4V is recommended. For a single ended application, the sample circuit from fig. 43 can be used. All single ended analog input pins (AGPI_A, AGPI_B and ADC_VM) have their negative input value tied to GNDA internally, so this sample circuit can also be used for them.

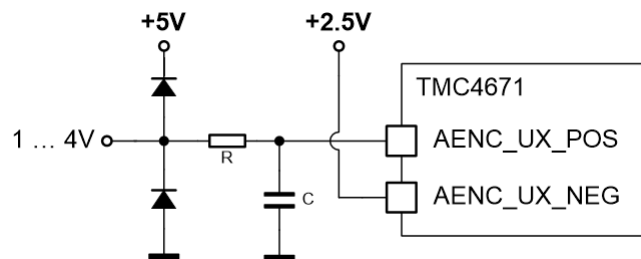

Figure 43: Sample Circuit for Interfacing of a single ended analog signal

If the power stage and the TMC4671 share a common ground, the ADC_VM input signal can be generated by a voltage divider to scale the voltage down to the needed range.

If the analog encoder has differential output signals, these can be used without signal conditioning (no OP AMPs), when voltage range matches. Differential analog inputs can be used to digitize differential analog input signals with high common mode voltage error suppression.

11.5 Phase Current Measurement

The TMC4671 requires two phase currents of a 2 or 3 phase motor to be measured. For a DC Motor only one current in the phase needs to be measured (see Fig. 45). In the ADC engine mapping of current signals to motor phases can be changed. Default setting is I0 to be the current running into the motor in phase U for a 3 phase motor. Respectively the current running into the motor from half-bridge X1 of a 2 phase motor. Figs. 44 and 45 illustrates the currents to be measured and their positive direction.



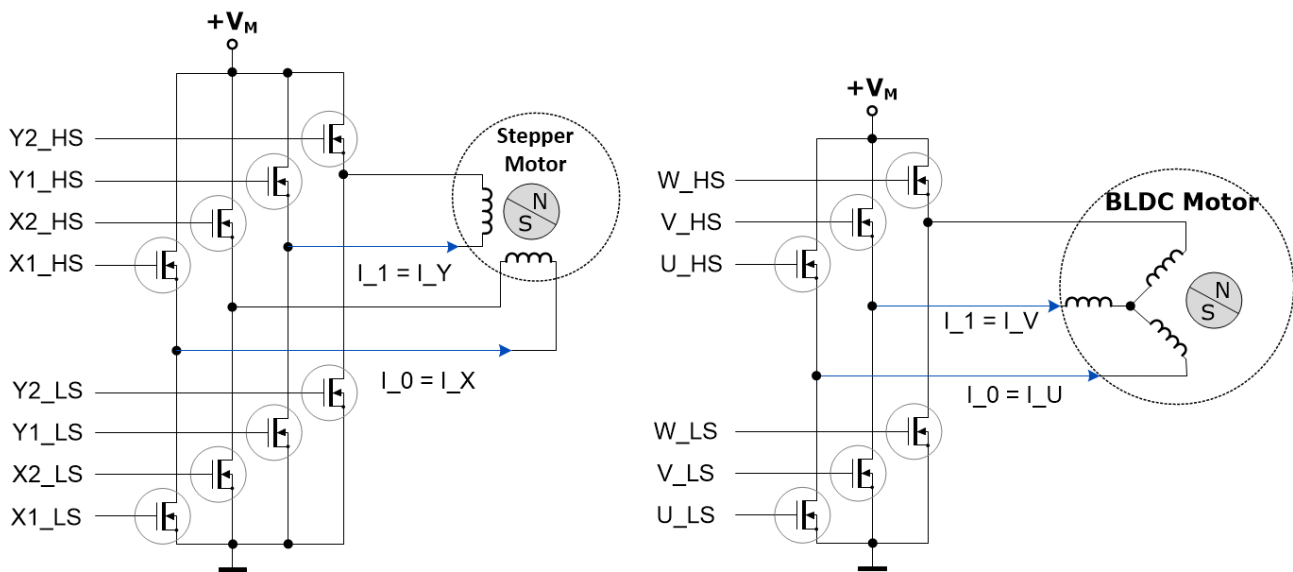

Figure 44: Phase current measurement: Current directions for 2 and 3 phase motors

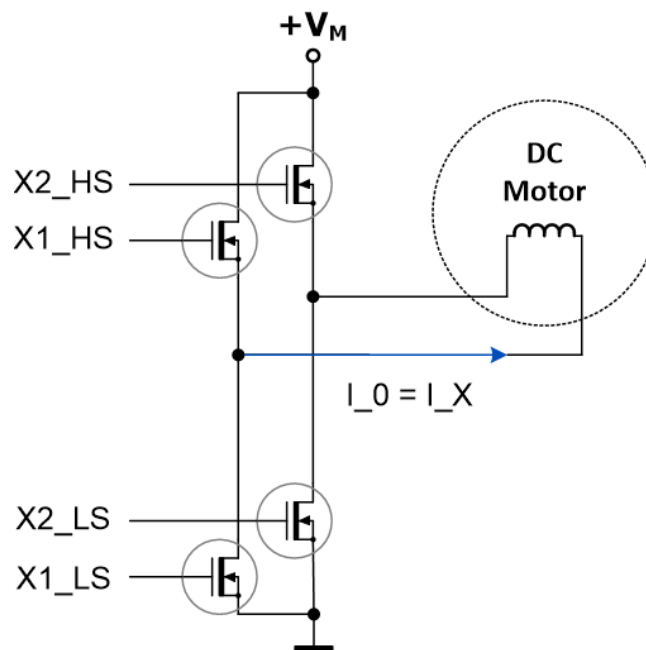

Figure 45: Phase current measurement: Current direction for DC or Voice Coil Motor

There are two main options for measuring the phase currents as described above. First option is to use a shunt resistor and a shunt amplifier like the [LT1999](#) or the [AD8418A](#). The other option is to use a real current sensor, which uses the Hall effect or other magnetic effects to implement an isolated current measurement. Shunt measurement might be the more cost-effective solution for low voltage applications up to 100V, while current sensors are more useful at higher voltage levels.

In general the sample circuit in fig. 46 can be used for shunt measurement circuitry. Please consider design guidelines of shunt amplifier supplier additionally. TRINAMIC also supplies power stage boards



with current shunt measurement circuitry (TMC-UPS10A/70V-EVAL). For current measurement also current sensors with voltage output can be used. These could use the Hall effect or other magnetic effects. Main concerns to take about is bandwidth, accuracy and measurement range.

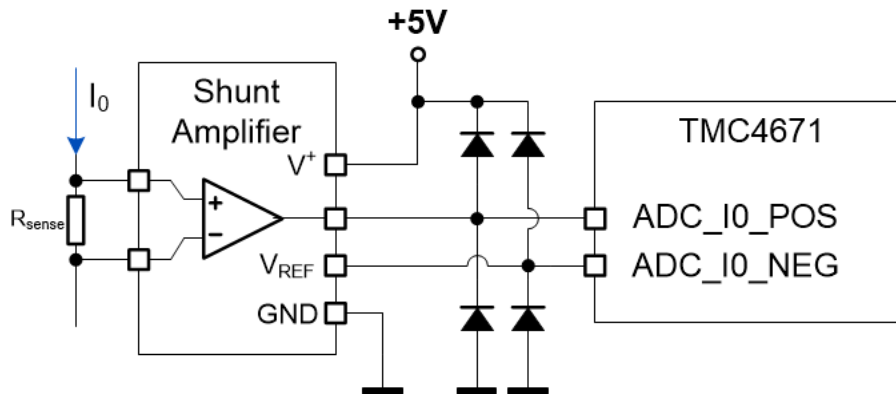

Figure 46: Current Shunt Amplifier Sample Circuit

11.6 Power Stage Interface

The TMC4671 is equipped with a configurable PWM engine for control of various gate drivers. Gate driver switch signals can be matched to power stage needs. This includes signal polarities, frequency, BBM-times for low and high side switches, and an enable signal. Please consider gate driver circuitry, when connecting to the TMC4671.



12 Setup Guidelines

For easy setup of the TMC4671 on a given hardware platform like the TMC4671 Evaluation-Kit, the user should follow these general guidelines in order to safely set up the system for various modes of operation.

i Info

These guidelines fit to hardware platforms which are comparable to the TMC4671-Evaluation Kit. If system structure differs, configuration has to be adjusted.

Please also make use of the RTMI Adapter and the TMCL IDE to setup the system as it reduces commissioning time significantly.

Step 0: Setup of SPI communication

As a first step of the configuration of the TMC4671 the SPI communication should be tested by reading and writing for example to the first registers for identification of the silicon. If communication fails, please check CLK and nRST signals. For easy software setup the TMC API provided on the TRINAMIC website can be used.

Step 1: Check connections

Register TMC_INPUTS_RAW can be accessed to see if all connected digital inputs are working correctly e.g. sensor signals can be checked by turning the motor manually.

Step 2: Setup of PWM and Gatedriver configuration

The user should choose the connected motor and the number of polepairs by setting register MOTOR_TYPE_N_POLE_PAIRS. For a DC motor the number of pole pairs should be set to one. The PWM can be configured with the corresponding registers PWM_POLARITIES (Gate Driver Polarities), PWM_MAXCNT (PWM Frequency), PWM_BBM_H_BBM_L (BBM times), and PWM_SV_CHOP (PWM mode). After setting the register PWM_SV_CHOP to 7 the PWM is on and ready to use.

Please check PWM outputs after turning on the PWM, if you are using a new hardware design.

Step 3: Open Loop Mode

In the Open Loop Mode the motor is turned by applying voltage to the motor. This mode is useful for test and setup of ADCs and position sensors. It is activated by setting the corresponding registers for PHI_E_SELECTION, and MODE_MOTION. With UD_EXT the applied voltage can be regulated upwards until the motor starts to turn. Acceleration and target velocity can be changed by their respective registers.

Step 4: Setup of ADC for current measurement

Please setup the current measurement by choosing your applications ADC configuration. Make sure to match decimation rate of the Delta Sigma ADCs to your chosen PWM frequency.

When the motor turns in Open Loop Mode the current measurement can be easily calibrated. Please match offset and gain of phase current signals by setting the corresponding registers. Please also make sure for a new hardware setup, that current measurements and PWM channels are matched. This can be done by matching phase voltages and phase currents. Register ADC_I_SELECT can be used to switch relations.

Step 5: Setup of Feedback Systems

In Open Loop Mode also the feedback systems can be checked for correct operation. Please configure registers related to used position sensor(s) and compare against Open Loop angles. Use encoder initialization routines to set angle offsets for relative position encoders according to application needs.

Step 6: Setup of FOC Controllers

Please configure your application's feedback system and configure position and velocity signal switches accordingly inside the FOC. Configure controller output limits according to you needs.

Setup PI controller parameters for used FOC controllers. Start with the current controller, followed by the velocity controller, followed by the position controller. Stop configuration at your desired cascade level.

TRINAMIC recommends to set the PI controller parameters by support of the RTMI, as it supports real-time access to registers and the TMCL IDE offers tools for automated controller tuning. Controller tuning without realtime access might lead to poor performance.

Please choose afterwards your desired Motion Mode and feed in reference values.



Step 7: Advanced Functions

For performance improvements Biquad filters and feed forward control can be applied.

13 Package Dimensions

Package: QFN76, 0.4 mm pitch, size 11.5 mm x 6.5 mm.

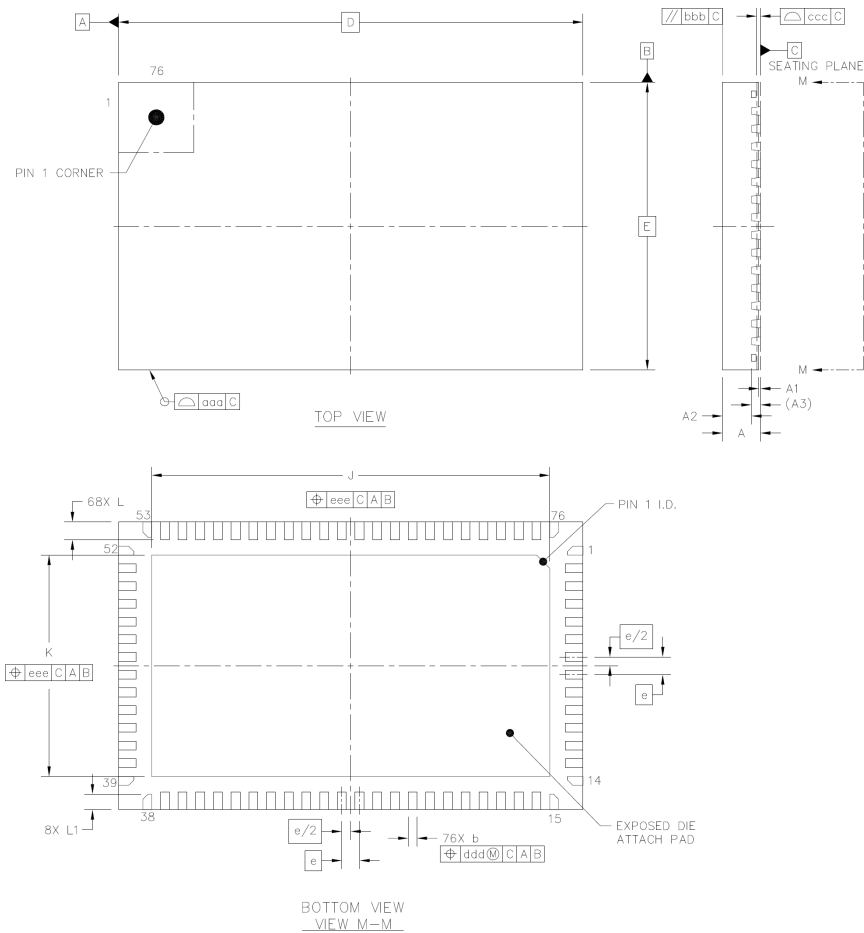

Figure 47: QFN76 Package Outline

QFN76 Package Dimensions in mm				
Description	Dimension[mm]	min.	typ.	max.
Total Thickness	A	0.80	0.85	0.90
Stand Off	A1	0.00	0.035	0.05
Mold Thickness	A2	—	0.65	—
L/F Thickness	A3		0.203 REF	
Lead Width	b	0.15	0.2	0.25
Body Width	D		10.5 BSC	



QFN76 Package Dimensions in mm				
Body Length	E	6.5 BSC		
Lead Pitch	e	0.4 BSC		
EP Size	J	8.9	9	9.1
EP Size	K	4.9	5	5.1
Lead Length	L	0.35	0.40	0.45
Lead Length	L1	0.30	0.35	0.40
Package Edge Tolerance	aaa	0.1		
Mold Flatness	bbb	0.1		
Coplanarity	ccc	0.08		
Lead Offset	ddd	0.1		
Exposed Pad Offset	eee	0.1		

Table 39: Package Outline Dimensions

Figure 48 shows the package from top view. Decals for some CAD programs are available on the product's website.



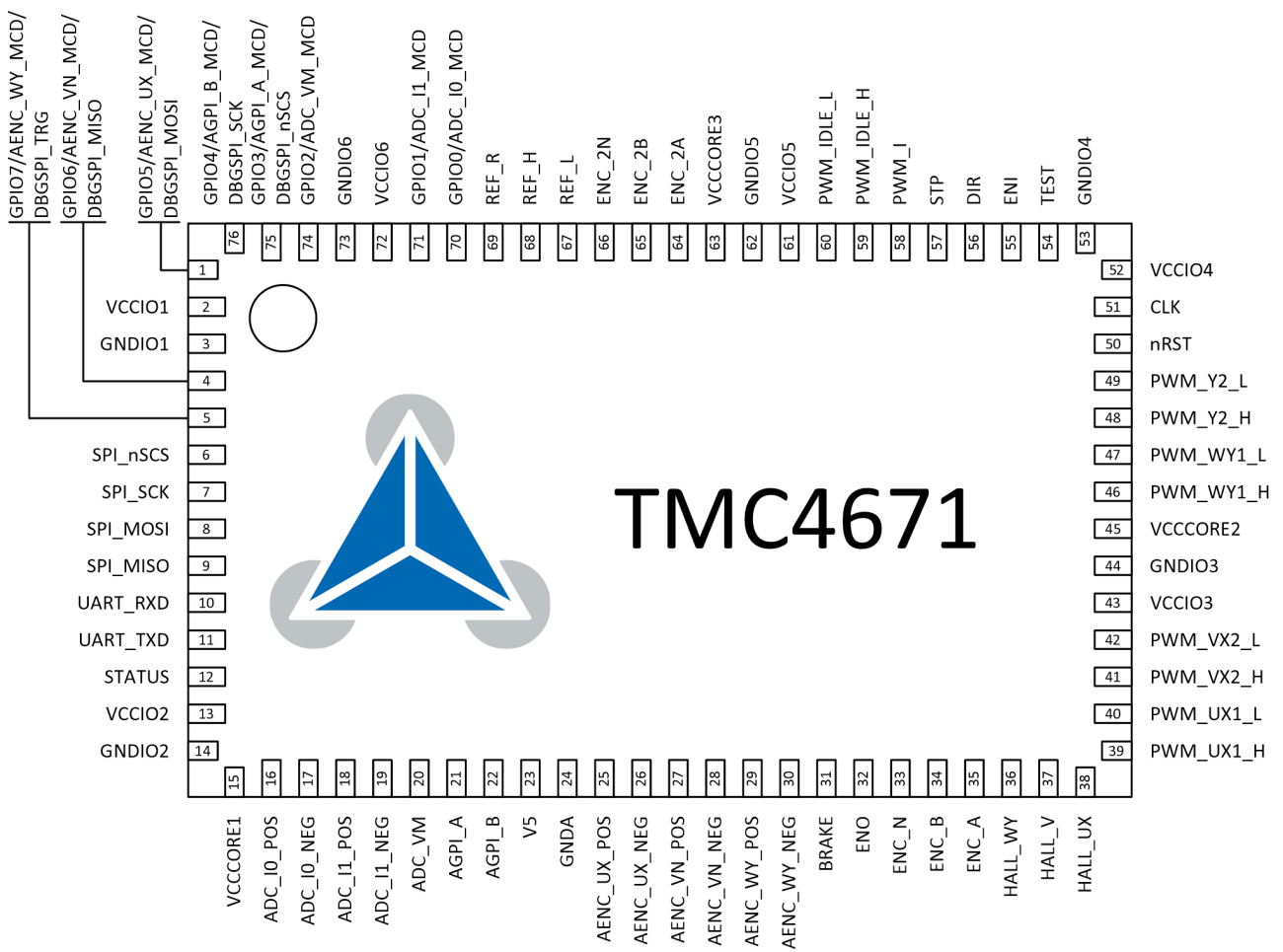

Figure 48: Pinout of TMC4671 (Top View)



14 Supplemental Directives

14.1 Producer Information

14.2 Copyright

TRINAMIC owns the content of this user manual in its entirety, including but not limited to pictures, logos, trademarks, and resources. © Copyright 2020 TRINAMIC. All rights reserved. Electronically published by TRINAMIC, Germany.

Redistributions of source or derived format (for example, Portable Document Format or Hypertext Markup Language) must retain the above copyright notice, and the complete Datasheet User Manual documentation of this product including associated Application Notes; and a reference to other available product-related documentation.

14.3 Trademark Designations and Symbols

Trademark designations and symbols used in this documentation indicate that a product or feature is owned and registered as trademark and/or patent either by TRINAMIC or by other manufacturers, whose products are used or referred to in combination with TRINAMIC's products and TRINAMIC's product documentation.

This Datasheet is a non-commercial publication that seeks to provide concise scientific and technical user information to the target user. Thus, trademark designations and symbols are only entered in the Short Spec of this document that introduces the product at a quick glance. The trademark designation /symbol is also entered when the product or feature name occurs for the first time in the document. All trademarks and brand names used are property of their respective owners.

14.4 Target User

The documentation provided here, is for programmers and engineers only, who are equipped with the necessary skills and have been trained to work with this type of product.

The Target User knows how to responsibly make use of this product without causing harm to himself or others, and without causing damage to systems or devices, in which the user incorporates the product.

14.5 Disclaimer: Life Support Systems

TRINAMIC Motion Control GmbH & Co. KG does not authorize or warrant any of its products for use in life support systems, without the specific written consent of TRINAMIC Motion Control GmbH & Co. KG.

Life support systems are equipment intended to support or sustain life, and whose failure to perform, when properly used in accordance with instructions provided, can be reasonably expected to result in personal injury or death.

Information given in this document is believed to be accurate and reliable. However, no responsibility is assumed for the consequences of its use nor for any infringement of patents or other rights of third parties which may result from its use. Specifications are subject to change without notice.

14.6 Disclaimer: Intended Use

The data specified in this user manual is intended solely for the purpose of product description. No representations or warranties, either express or implied, of merchantability, fitness for a particular purpose



or of any other nature are made hereunder with respect to information/specification or the products to which information refers and no guarantee with respect to compliance to the intended use is given.

In particular, this also applies to the stated possible applications or areas of applications of the product. TRINAMIC products are not designed for and must not be used in connection with any applications where the failure of such products would reasonably be expected to result in significant personal injury or death (safety-Critical Applications) without TRINAMIC's specific written consent.

TRINAMIC products are not designed nor intended for use in military or aerospace applications or environments or in automotive applications unless specifically designated for such use by TRINAMIC. TRINAMIC conveys no patent, copyright, mask work right or other trade mark right to this product. TRINAMIC assumes no liability for any patent and/or other trade mark rights of a third party resulting from processing or handling of the product and/or any other use of the product.

14.7 Collateral Documents & Tools

This product documentation is related and/or associated with additional tool kits, firmware and other items, as provided on the product page at: www.trinamic.com.



15 Fixes of TMC4671-LA/-ES2 vs. Errata of TMC4671-ES

#	TMC4671-ES Erratum	TMC4671-LA Fix	Description
1	SPI slave MSB read error	SPI slave correction	read via SPI slave now works correct
2	RTMI critical timing	RTMI enhanced	RTMI works with isolated RTMI-USB IF
3	PI advanced controller	PI scaling updated	scaling selectable available
4	ADC group clock cross talk	ADC clocks corrected	crosstalk eliminated
5	PWM_IDLE_L/_H un-used	PWM outputs are at high impedance until ENI is high	User can configure PWM signal polarity and afterwards enable PWM signals. Idle state can be set with PD or PU resistor on PWM outputs
6	Space Vector PWM	SVPWM scaling corrected	SVPWM gives +12% effective voltage. With Space Vector PWM enabled voltage scaling is modified.
7	step direction target position	processing corrected	step direction as target position
8	ABN encoder register access	access corrected	ABN counter over-writeable
9	ENI and ENO	function updated	ENI and ENO act as enable signals
10	-	Hall sync PWM sample	optional Hall sampling at PWM center
11	-	PWM_POLARITIES register initialized to 0x0	Active high PWM signal polarity is preferred
12	-	Registers PHI_M_EXT and POSITION_EXT removed	Registers were not used
13	Watchdog not properly working	Watchdog removed	Watchdog was intended to monitor CLK. Watchdog flag can not be reset.

Table 40: TMC4671-ES Errata vs. TMC4671-ES2/-LA Fixes

15.1 Errata of TMC4671-ES Engineering Samples as Reference

1. SPI Slave Interface
The SPI Slave Interface in the TMC4671-ES might show corrupted MSB of read data.
2. Realtime Monitoring Interface
The RTMI of TMC4671-ES could not be used with galvanic isolation due to timing issue.
3. PI Controllers
The P Factor of the TMC4671-ES in the advanced position controller was not properly scaled and the integrator in the advanced PI controller was not reset when P or I parameters are set to zero.
4. Integrated ADCs
The Delta Sigma ADCs of TMC4671-ES showed signal cross talk caused by ADC clock cross talk.



5. Pins PWM_IDLE_H and PWM_IDLE_L without function
Pins PWM_IDLE_H and PWM_IDLE_L of TMC4671-ES were proposed to set gate driver control polarity.
6. Space Vector PWM does not allow higher voltage utilization
The Space vector PWM of the TMC4671-ES does not allow higher voltage utilization.
7. Step Direction Counter not used as Target Position
The step direction counter of the TMC4671-ES correctly counts but is not available as target position.
8. Register write access to ABN encoder count register and N pulse status bits
Write access to count registers of TMC4671-ES cleared these to zero and encoder N pulse input signals were not available within the status register.
9. ENO and ENI
ENI (ENable Input) and ENO (ENable Output) of TMC4671-ES did partially work as intended (incomplete reset assignment, missing error sum clear on disable).

15.2 Actions to Avoid Trouble

What should be taken into account when moving from TMC4671-ES to TMC4671-LA?

- update P and I parameter for the advanced PI controller in case of switching numerical representation from Q8.8 to Q4.12 (classical PI controller is un-changed)
- mount pull-up resistors if required for gate driver control signals during power-on reset
- check setting of SVPWM control bit to avoid un-wanted speed-up by SVPWM in torque mode (power-on default is disable without speed-up)
- check setting of additional hall_sync_pwm_enable bit for high speed application with usage of Hall signals (power-on default is disable)

15.3 Recommendations

- TMC4671-LA (TMC4671-ES2) is drop-in compatible to the TMC4671-ES. Nevertheless, the TMC4671-LA needs to be functional qualified as replacement to avoid un-wanted behavior caused by corrections of errata of TMC4671-ES.

For example: The space vector PWM (SVPWM) control bit does not have an effect for the TMC4671-ES in torque mode. The space vector PWM is corrected for the TMC4671-LA. So, if the SVPWM control bit is un-wanted enabled for the TMC4671-ES, the TMC4671-LA would run approximately +12% faster in torque mode with the same settings.



16 Figures Index

1	FOC Basic Principle	9	24	Outline of noisy Hall signals (left) due to electromagnetic interference with PWM switching and noise cleaned Hall signals (right) by PWM center synced sampling of Hall signal vector (H1 H2 H3)	47
2	PID Architectures and Motion Modes	10	25	Hall Signal PWM Center Sampling on PWM_CENTER	47
3	Orientations UVW (FOC3) and XY (FOC2)	15	26	Hall Signal Blanking	47
4	Compass Motor Model w/ 3 Phases UVW (FOC3) and Compass Motor Model w/ 2 Phases (FOC2)	15	27	Analog Encoder (AENC) signal waveforms	48
5	Hardware FOC Application Diagram	16	28	Analog Encoder (AENC) Selector & Scaler w/ Offset Correction	49
6	Hardware FOC Block Diagram	16	29	Classic PI Controller Structure	54
7	SPI Datagram Structure	17	30	Advanced PI Controller Structure	55
8	SPI Timing	18	31	PI Controllers for position, velocity and current	56
9	SPI Timing of Write Access without pause with fSCK up to 8MHz	19	32	Inner FOC Control Loop	57
10	SPI Timing of Read Access with pause (tPAUSE) of 500 ns with fSCK up to 8MHz.	19	33	FOC Transformations	58
11	Connector for Real-Time Monitoring Interface (Connector Type: Hirose DF20F-10DP-1V)	20	34	Motion Modes	58
12	UART Read Datagram (TMC4671 register read via UART)	22	35	Biquad Filters in Control Structure	61
13	UART Write Datagram (TMC4671 register write via UART)	22	36	PWM Gate Driver Control Polarities	62
14	N_POLE_PAIRS - Number of Pole Pairs (Number of Poles)	26	37	FOC3 (three phase motor), FOC2 (two phase stepper motor), FOC1 (single phase DC motor)	63
15	Integer Representation of Angles as 16 bit signed (s16) resp. 16 bit unsigned (u16)	27	38	BBM Timing	64
16	Input Voltage Ranges of internal Delta Sigma ADC Channels	31	39	TMC4671 Pinout with 3 phase Power stage and BLDC Motor	128
17	Delta Sigma ADC Configurations dsADC_CONFIG (ANALOG (internal), MCLKO, MCLKI, MDAC)	33	40	TMC4671 Pinout with Stepper Motor	128
18	$\Delta\Sigma$ ADC Configurations - MDAC (Comparator-R-C-R as $\Delta\Sigma$ -Modulator)	37	41	TMC4671 Pinout with DC Motor or Voice Coil	129
19	ADC Selector and Scaler with Offset Correction	41	42	Sample Circuit for Interfacing of an Encoder Signal	136
20	Number of Pole Pairs npp vs. mechanical angle ϕ_m and electrical angle ϕ_e	43	43	Sample Circuit for Interfacing of a single ended analog signal	137
21	ABN Incremental Encoder N Pulse	44	44	Phase current measurement: Current directions for 2 and 3 phase motors	138
22	Encoder ABN Timing	45	45	Phase current measurement: Current direction for DC or Voice Coil Motor	138
23	Hall Sensor Angles	46	46	Current Shunt Amplifier Sample Circuit	139
			47	QFN76 Package Outline	141
			48	Pinout of TMC4671 (Top View)	143



17 Tables Index

1	Order codes	6	19	Example Parameters for ADC_GAIN . . .	39
2	SPI Timing Parameter	18	20	Scalings and Change Rate Timings of classical PID controllers for currents, velocity, and position	53
3	Possible baudrates and corresponding values for register 0x79	21	21	Motion Modes	53
4	Single Pin Interface Motion Modes . . .	23	22	Motion Modes	59
5	GPIO Configuration Overview with 'x' as don't care	24	23	TABStatusFlags	62
6	Numerical Representations	24	24	FOC321 Gate Control Signal Configurations	63
7	Examples of u16, s16, q8.8, q4.12 . . .	25	25	Factors for integer to real conversion .	65
8	Examples of u16, s16, q8.8	27	26	Factors for real to integer conversion .	66
9	Delta Sigma $\Delta\Sigma$ ADC Input Stage Configurations	30	27	TABStatusFlags	67
10	Delta Sigma $\Delta\Sigma$ ADC Input Stage Configurations	31	28	TMC4671 Registers	75
11	$\Delta\Sigma$ ADC Configurations	33	31	Pin Type Definition	129
12	Registers for Delta Sigma Configuration	34	32	Functional Pin Description	132
13	Delta Sigma MCLK Configurations . . .	34	33	Supply Voltage Pins and Ground Pins .	133
14	Recommended Decimation Parameter MDEC	35	34	Absolute Maximum Ratings	134
15	Recommended input voltage range from V_MIN25%[V] to V_MAX75%[V] for internal Delta Sigma Modulators; V_SUPPLY[V] = 5V is recommended for the analog part of the TMC4671.	36	35	Operational Range	134
16	Delta Sigma input voltage mapping of internal Delta Sigma Modulators	36	36	DC Characteristics	135
17	Delta Sigma R-C-R-CMP Configurations	37	37	Additional decoupling capacitors for supply voltages	136
18	Delta Sigma input voltage mapping of external comparator (CMP)	38	38	Reference Values for circuitry components	137
			39	Package Outline Dimensions	142
			40	TMC4671-ES Errata vs. TMC4671-ES2/-LS Fixes	146
			41	IC Revision	150
			42	Document Revision	151



18 Revision History

18.1 IC Revision

Version	Date	Author	Description
V1.0	2017-JUL-03	LL, OM	Engineering samples TMC4671-ES (1v0 2017-07-03-19:43)
V1.3	2019-APR-30	LL, OM	Release version TMC4671-LA (1v3 2019-04-30-12:55)

Table 41: IC Revision

18.2 Document Revision

Version	Date	Author	Description
V0.9	2017-SEP-29	LL, OM	Pre-liminary TMC4671-ES datasheet.
V0.91	2018-JAN-30	OM	Changed some typos and added some notes.
V0.92	2018-FEB-28	OM	Changed register descriptions.
V0.93	2018-MAR-07	OM	Changed some typos and bugs in graphics.
V0.94	2018-MAR-14	OM	Added Errata Section.
V0.95	2018-MAY-08	OM	Preparations for launch.
V1.00	2018-JUN-28	LL	Errata Section updated concerning Step/Dir.
V1.01	2018-JUL-19	OM	Added Description for Status Flags
V1.02	2018-JUL-31	OM	Added Description for Feed Forward Control Structure
V1.03	2018-SEP-06	OM	Description of single pin interface and motion modes added
V1.04	2018-DEC-11	OM	Register map and pictures of PI controllers corrected
V1.05	2019-JAN-02	OM	Figure 9 corrected, order codes for eval kits added.
V1.06	2019-FEB-06	OM	Reference switch processing explained.
V1.07	2019-MAR-22	LL	errata updated concerning encoder N pulse, ENI and ENO; figure illustrating PPR, NPP, phi_m, phi_e added; PWM polarities and Hall signal blanking explained in more detail together with drawings.
V1.99	2019-SEP-12	LL	register map structure with enhanced readability, minimal move PI controller section of TMC4671-ES removed for TMC4671-LA; SPI timing with tPAUSE added; figure of Hall signal PWM synced sampling option added; section ADC Gain Factors added; section ADC engine updated; sense amplifier type corrected to AD8418; LM319 removed as dsMOD example; ADC engine section updated; PWM Engine FOC321 with associated motor connectors added; PID T_N (Nachstellzeit = Reset Time) dsADC input stage configuration, ADC real world scaling (IgainADC[A/LSB], UgainADC[V/LSB]) added, errata section updated;



Version	Date	Author	Description
V1.99	2019-DEC-06	LL	functional summary updated for TMC4671-LA, FOC basics updated, functional description updated, SPI read write access timing updated for TMC4671-LA, ADC Engine section updated w/ voltage scalings, step direction interface correction updated, order codes updated, section 'Calculative PI Controller Setup - Classic Structure' added; TMC4671-ES Erratum vs. TMC4671-LA fixes added, PWM center Hall vector sampling added; section watchdog updated; section fixes vs. errata updated concerning actions to avoid trouble with recommendations; section How to Turn a Motor updated; entry (signal of max. of q4.12) in table (6) corrected,
V1.99	2019-DEC-20	LL	watchdog section updated, order codes updated, 1st page block diagram updated, DS_ANALOG_INPUT_STAGE_CFG updated
V1.99	2020-FEB-10	LL	Encoder Engine section: mechanical position (ϕ_m) corrected, section Safety Functions: hint according to status bit write added,
V2.00	2020-APR-16	OM	feedforward control and PI control section updated; ENO/ENI pin functionality added; Register map updated
V2.01	2020-JUL-13	KK	Register map updated (added missing registers, removed unused registers), added section for controller sampling rates, added table for real2int and int2real conversions, added section for GPIO-usage, updated controller q8.8 and q4.12 representation, fixed num_representation for angles
V2.02	2020-SEP-22	OM	Register map updated (removed feed forward control registers), added descriptions for register usage and register function, fixed exponents in tables for real/integer pwm conversion, updated feedforward, updated AENC_DECODER_MODE register info and infobox in Analog Hall and Analog Encoder Interface
V2.03	2020-OCT-08	KK	Fixed several typos, added missing information about UART baudrate in 4.2.3, fixed default values for UART_BPS register and added hint in registermap about baudrate settings.

Table 42: Document Revision



X-ON Electronics

Largest Supplier of Electrical and Electronic Components

Click to view similar products for [Motor/Motion/Ignition Controllers & Drivers](#) category:

Click to view products by [Analog Devices](#) manufacturer:

Other Similar products are found below :

[FSB50550TB2](#) [MSVCPM2-63-12](#) [MSVGW45-14-2](#) [MSVGW54-14-3](#) [NTE7043](#) [LA6565VR-TLM-E](#) [LB1837M-TLM-E](#) [STK534U342C-E](#)
[AM4967GSTR-G1](#) [TB6562AFG\(O,8,EL\)](#) [BA5839FP-E2](#) [VND5T050AK-E](#) [LA6584JA-AH](#) [LB11961-W-AH](#) [LC898212XD-SH](#)
[NCV70501DW002R2G](#) [TND315S-TL-2H](#) [FSB50250AB](#) [FNA41060](#) [MSVBTC50E](#) [MSVCPM3-54-12](#) [MSVCPM3-63-12](#) [MSVCPM4-63-12](#)
[FSB50550AB](#) [L99MC6TR](#) [LC898301XA-MH](#) [LV8413GP-TE-L-E](#) [MSVGW45-14-3](#) [MSVGW54-14-4](#) [TB6552FNG,C,8,EL](#) [LB11651-E](#)
[IRSM515-025DA4](#) [LV8127T-TLM-H](#) [MC33812EKR2](#) [MC33PT2000AF](#) [LB11851FA-BH](#) [LB1938FAGEVB](#) [TB6569FTG,8,EL](#)
[STIPN2M50-H](#) [BH67172NUX-GE2](#) [RSHR4006BV20](#) [DMPU-CPAN](#) [DMPU-CPC](#) [DMPUC-R2](#) [AIS-D-42MA](#) [FNB81560T3](#)
[NCV7535DBR2G](#) [NCP81274MNTXG](#) [PT8A2767FWEX](#) [LB11685AV-W-AH](#)