

TMCC160-EVAL MANUAL

TMCC160 TMCL Hardware Version 1.1 | Document Revision 1.02 • 2017-OCT-06

The TMCC160-EVAL is designed for evaluating all features of the TMCC160-LC motionCookie™. The integrated ARM Cortex-M4 microcontroller is used to control one PMSM/BLDC axis. The power MOSFETs are able to drive up to 10A (RMS) motor current. Several interfaces are supported on the evaluation board (see features).

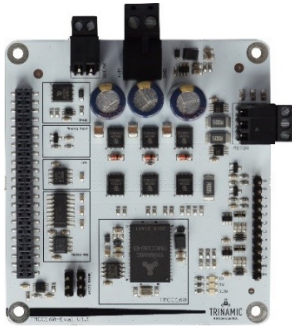

Features

- FOC torque-, velocity- and position-control for PMSM/BLDC 3-phase motors
- Encoder and hall sensor-based operation
- Up to 10A RMS nominal motor current
- Supply voltage: +7V... +24V DC operating voltage
- Interfaces: RS232, RS485, CAN, SPI™
- 2x reference switch inputs
- 1x analog input

Figure 1: TMCC160-EVAL

Applications

- Robotics
- Pump and Fan Applications
- Industrial Automation
- Medical
- Lab Automation

Block Diagram

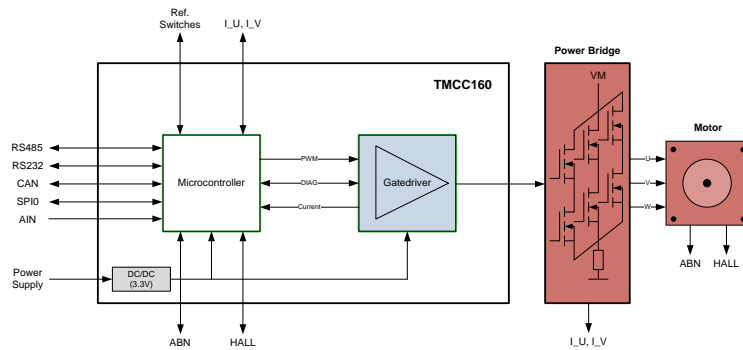

Figure 2: Simplified Block Diagram

Order Code

Order code	Description	Size
TMCC160-EVAL	Evaluation board for TMCC160 single axis BLDC controller.	85 x 79 x 34

Table 1: TMCC160 Order Code

SUPPLEMENTAL DIRECTIVES

© 2015 TRINAMIC Motion Control GmbH & Co. KG, Hamburg, Germany — Terms of delivery and rights to technical change reserved. Download newest version at: www.trinamic.com .

Read entire documentation; especially the Supplemental Directives.



Read the entire documentation before you make use of this product:

- Ensure you meet the *Target User Requirements* on page [13](#).
- Read the *User Information and Directives* provided on page [13](#).
- Read the *ESD-Sensitivity Directives* provided on page [13](#).

Keep this manual and all other applicable and related documents complete, legible and accessible to the specified user at all times.

Failure to observe the *Supplemental Directives* could result in damage to product and things; to property or persons; or economic loss.



TRINAMIC is not liable for damages incurred as a result of improper use or disregard of the instructions provided in this *document*.

Please refer to our *User Information and Directives* for more details (page [13](#)).

Contact
TRINAMIC
support team

In case you encounter difficulties or need additional advice, please contact our support team via: www.trinamic.com. Thank you.



TABLE OF CONTENTS

TMCC160-EVAL Manual	1
Order Code.....	1
SUPPLEMENTAL DIRECTIVES	1
Contact <i>TRINAMIC support team</i>	2
TABLE OF CONTENTS	3
1.1 Connector Overview	4
1.2 LEDs	7
1.3 RS232, RS485 Interface Switch	8
2 Operational Ratings of TMCC160-EVAL	9
3 Getting Started	10
Preparations	10
Start-up Preparations	11
Graphic Overview: Getting Started	11
USER INFORMATION AND DIRECTIVES	13
ESD-DEVICE INSTRUCTIONS	13
Producer Information	13
Copyright	13
Target User	13
Disclaimer: Life Support Systems	13
Disclaimer: Intended use	13
TMCC160-EVAL Document Info	14
Related Documents	14
Collateral documents	14
REVISION HISTORY	15
Hardware Product Revision History (HW V.).....	15
REFERENCES	15
Related Documents and Tools.....	15
TABLE INDEX	16
FIGURE INDEX	16
CLOSING NOTE	16
Hardware	



1.1 Connector Overview

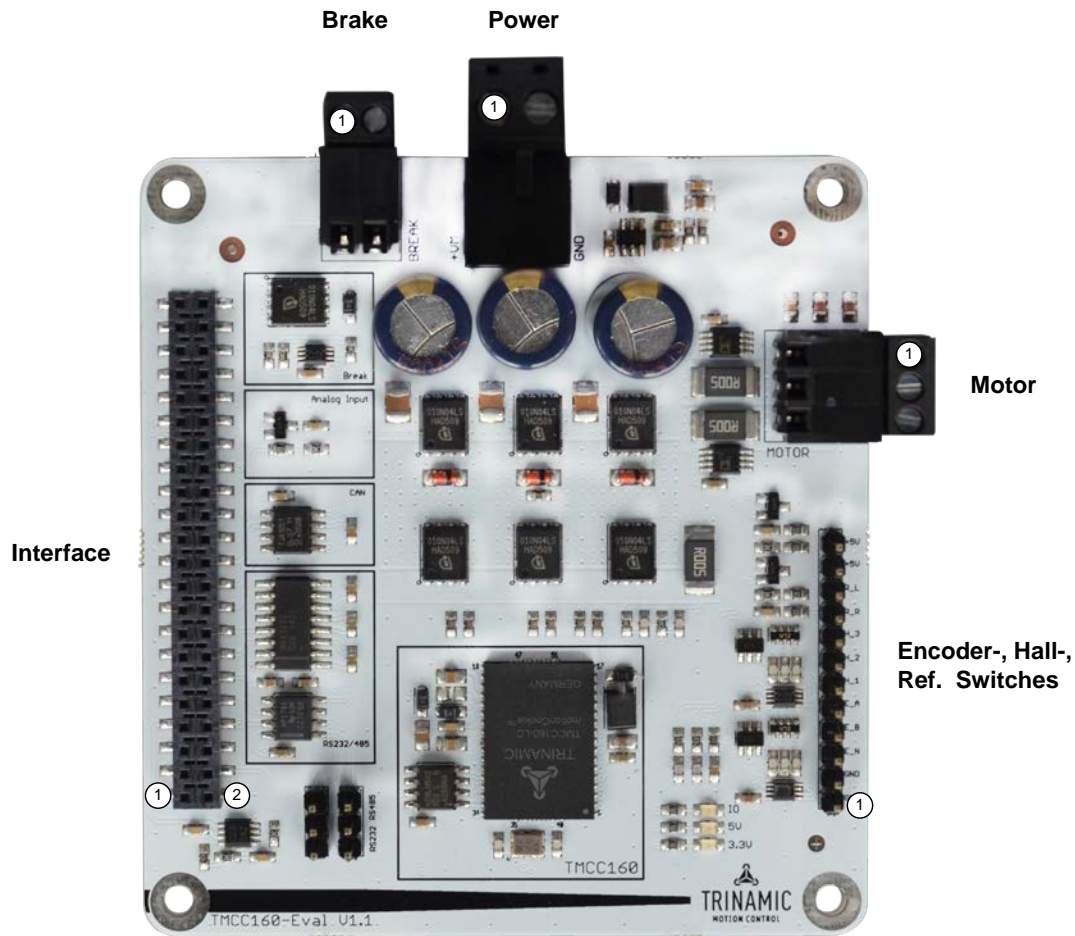

Figure 3: TMC160-EVAL Connectors

TMCC160-EVAL Connectors		
Label (Key)	Connector Type	Mating Connector Type
Power	RIA 330-02, 2 pol., 5mm pitch, shrouded header	RIA 349-2, screw type terminal block, pluggable, centerline 5 mm / 0.197 inches, wire entry parallel to plug direction
Brake	RIA 182-02, 2 pol., 3.5mm pitch, header	RIA 169-02, screw type terminal block, pluggable, centerline 3.5 mm / 0.138 inches, wire entry parallel to plug direction
Motor	RIA 182-03, 3 pol., 3.5mm pitch, header	RIA 169-03, screw type terminal block, pluggable, centerline 3.5 mm / 0.138 inches, wire entry parallel to plug direction
Encoder-, Hall-, Ref. Switches	Standard male 12 pin connector, one row, 2.54mm pitch	Standard female 12 pin connector, one row, 2.54mm pitch



TMCC160-EVAL Connectors		
Label (Key)	Connector Type	Mating Connector Type
Interface	2 x 22 pol., 2.54mm pitch, pluggable female connector 2 x 22 pol., 2.54mm pitch, pluggable male connector	2 x 22 pol., 2.54mm pitch, pluggable female connector 2 x 22 pol., 2.54mm pitch, pluggable male connector

Table 2: TMC5031-EVAL Connectors

This connector fits for commercially available power supply units for e.g. 24V DC.

Power Connector		
Pin	Label	Description
1	+VM	Power supply input +7V .. 24V DC
2	GND	System GND

Table 3: Power Connector

Brake Connector		
Pin	Label	Description
1	Brake	Open collector brake output.
2	+VM	Power supply output

Table 4: Brake Connector

Motor Connector		
Pin	Label	Description
1	W	Motor coil W
2	V	Motor coil V
3	U	Motor coil U

Table 5: Motor Connector

Encoder-, Hall-, Ref. Switches Connector			
Pin	Label	Pull-up	Description
1	GND	-	System GND
2	GND	-	System GND
3	ENC_N	4k7	Encoder index channel input.
4	ENC_B	4k7	Encoder quadrature channel B input.
5	ENC_A	4k7	Encoder quadrature channel A input.
6	HALL_1	4k7	Hall signal 1 input.
7	HALL_2	4k7	Hall signal 2 input.
8	HALL_3	4k7	Hall signal 3 input.
9	REF_R	3k3	Right reference switch input.
10	REF_L	3k3	Left reference switch input.



Encoder-, Hall-, Ref. Switches Connector			
11	+5V	-	Supply output for encoder-, hall-sensors
12	+5V	-	Supply output for encoder-, hall-sensors

Table 6: Encoder-, Hall-, Reference Switches Connector

Interface Connector		
Pin	Label	Description
1	+VM	Power supply.
2	GND	System GND.
3	GND	System GND.
4	ID_CLK	STARTRAMPE: clock pulse test point.
5	-	Not used.
6	ID_CH0	ID channel 0. Not used with TMCC160-EVAL.
7	ID_CH1	ID channel 1. Used for automatic module detection.
8	ENABLE	TMCC160 enable signal. Use open collector output only to switch enable signal to GND.
9	-	Not used.
10	RS485_B-	Negative differential RS485 interface signal.
11	-	Not used.
12	RS485_A+	Positive differential RS485 interface signal.
13	-	Not used.
14	RS232_TX	RS232 interface output.
15	-	Not used.
16	RS232_RX	RS232 interface input.
17	-	Not used.
18	CAN_H	CAN high interface signal.
19	-	Not used.
20	CAN_L	CAN low interface signal.
21	-	Not used.
22	AIN	10V analog input.
23	-	Not used.
24	-	Not used.
25	-	Not used.
26	-	Not used.
27	-	Not used.
28	-	Not used.
29	-	Not used.
30	CSN	SPI interface chip select signal. Low active.
31	SCLK	SPI interface clock signal.
32	MOSI	SPI interface master out slave in signal.
33	MISO	SPI interface master in slave out signal.
34	-	Not used.
35	-	Not used.
36	-	Not used.
37	-	Not used.
38	-	Not used.
39	-	Not used.
40	-	Not used.
41	-	Not used.
42	-	Not used.
43	GND	System ground.



Interface Connector		
Pin	Label	Description
44	GND	System ground.

Table 7: Interface Connector

1.2 LEDs

The **TMCC160-EVAL** has **three LEDs**. Two of them indicate the digital 3.3V (LED1) and 5V (LED2) power supply. The third LED is connected with the brake chopper output pin. Whenever the brake chopper is active LED3 is on.



Figure 4: LEDs



1.3 RS232, RS485 Interface Switch

TMCC160-EVAL board supports RS232 or RS485 interface. To switch between both two jumpers have to be configured as described in the table below.

RS232, RS485 Interface Switch		
Connector	PIN	Description
	1-2	If pin 1 and 2 of the interface switch is connected, RS485 interface is active.
	2-3	If pin 2 and 3 of the interface switch is connected, RS232 interface is active.

Table 8: RS232, RS485 Interface Switch



2 Operational Ratings of TMCC160-EVAL

The operational ratings shown below should be used as design values. The maximum power supply current depends on the used motors and the supply voltage.

AREAS OF SPECIAL CONCERN

- Do not exceed the maximum values during operation! Otherwise the driver will be damaged!

General Operational Ratings of the Module					
Symbol	Parameter	Min	Type	Max	Unit
+VM	Power supply voltage for operation	7	24	28	V
V _{AIN}	10V analog input voltage (24V compatible)		10	24	V
V _{ENC_x}	Encoder input signals	0	5	5.1	V
V _{HALL_x}	Hall sensor input signals	0	5	5.1	V
V _{REF_x}	Reference input signals	0	5	5.1	V
I _{Motor}	Motor coil current [RMS]		10		A
I _{SUPPLY}	Power supply current			10	A
T _{ENV}	Environment temperature at rated current (no forced cooling required)		20°C		°C

Table 9: General Operational Ratings of the Module



3 Getting Started



Follow guidelines provided in this chapter:

- Disconnect power supply.
- Read safety instructions.
- Follow configuration guidelines.

Failure to observe could result in damage to product and things; to property or persons; or economic loss.

Preparations

You need:

- TMCC160-EVAL
- RS232, RS485, CAN interface
- PMSM/BLDC motor
- TMCL-IDE V3. And PC
- Cables for interface, motor, and power supply
- Nominal supply voltage +24V DC (+7...+24V DC)

Before You Connect the Devices

CAUTION

Minor injuries or unintended system behavior through incorrect handling!

- Do NOT connect or disconnect the motor while still powered.
 - Do NOT mix up connections and short-circuit pins.
 - Do NOT bound I/O wires with motor wires.
 - Do NOT exceed the maximum power supply of +28 DC.
-

Connect all devices according to specification and user manual instructions in order to ensure safe handling and correct system behavior.



Start-up Preparations

The following actions have to be carried out prior to start-up:

Action 1:

- Download the TMCL-IDE 3.0 from www.trinamic.com and install it.

Result:

The TMCL-IDE then opens automatically.

Action 2:

- **Step 1:** Connect one of the supported interfaces to the TMCC160-EVAL board.
- **Step 2:** Connect a PMSM/BLDC motor with hall- or encoder sensor to the specific connectors.
- **Step 3:** Connect the +24V power supply to the TMCC160-EVAL board
- **Step 4:** Turn power ON. The green LEDs one and two should turn ON
- **Step 5:** Start TMCL-IDE V3.0 and select connected interface.

Result:

Now, all your connections have been established in order to start up the system,

NOTE:

- *Default interface settings:*
RS232: 115.200 kbit/s
RS485: 115.200 kbit/s
CAN: 1Mbit/s

Graphic Overview: Getting Started

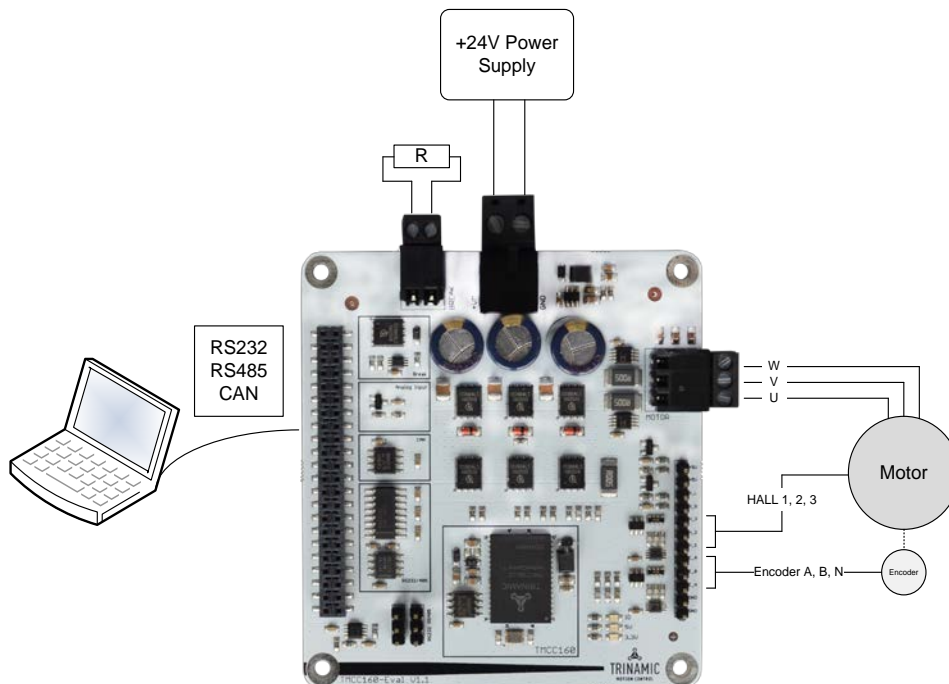

Figure 5: Graphic Overview: Getting Started

TMCC160-EVAL Size and Mounting Holes

The board dimensions are 85mm x 79mm. Maximum component height (above PCB level) without mating connectors is 32mm. There are four mounting holes suitable for M3 screws.



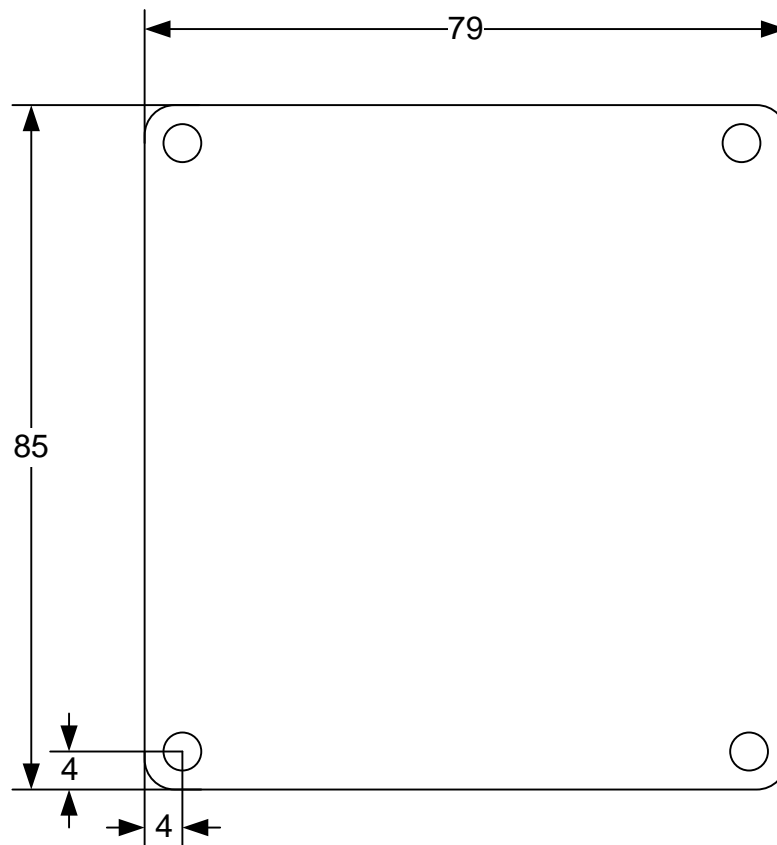
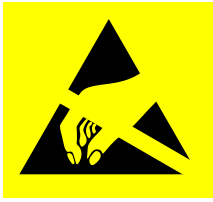

Figure 6: TMCC160-EVAL Dimensions



USER INFORMATION AND DIRECTIVES

ESD-DEVICE INSTRUCTIONS



This product is an ESD-sensitive CMOS device. It is sensitive to electrostatic discharge.

- Provide effective grounding to protect personnel and machines.
- Ensure work is performed in a non-static environment.
- Use personal ESD control footwear and ESD wrist straps, if necessary.

Failure to do so can result in defects, damages and decreased reliability.

Producer Information

The producer of the product TMCC160 is TRINAMIC GmbH & Co. KG in Hamburg, Germany; hereafter referred to as TRINAMIC. TRINAMIC is the supplier; and in this function provides the product and the production documentation to its customers

Copyright

TRINAMIC owns the content of this user manual in its entirety, including but not limited to pictures, logos, trademarks, and resources.

© Copyright 2015 TRINAMIC®. All rights reserved. Electronically published by TRINAMIC®, Germany. All trademarks used are property of their respective owners.

Redistributions of source or derived format (for example, Portable Document Format or Hypertext Markup Language) must retain the above copyright notice, and the complete Datasheet User Manual documentation of this product including associated Application Notes; and a reference to other available product-related documentation.

Target User

The documentation provided here, is for programmers and engineers only, who are equipped with the necessary skills and have been trained to work with this type of product.

The *Target User* knows how to responsibly make use of this product without causing harm to himself or others, and without causing damage to systems or devices, in which the user incorporates the product.

Disclaimer: Life Support Systems

TRINAMIC Motion Control GmbH & Co. KG does not authorize or warrant any of its products for use in life support systems, without the specific written consent of TRINAMIC Motion Control GmbH & Co. KG.

Life support systems are equipment intended to support or sustain life, and whose failure to perform, when properly used in accordance with instructions provided, can be reasonably expected to result in personal injury or death.

Information given in this document is believed to be accurate and reliable. However, no responsibility is assumed for the consequences of its use nor for any infringement of patents or other rights of third parties which may result from its use. Specifications are subject to change without notice.

Disclaimer: Intended use

The data specified in this user manual is intended solely for the purpose of product description. No representations or warranties, either express or implied, of merchantability, fitness for a particular purpose or of any other nature are made hereunder with respect to information/specification or the products to which information refers and no guarantee with respect to compliance to the intended use is given.



In particular, this also applies to the stated possible applications or areas of applications of the product. TRINAMIC products are not designed for and must not be used in connection with any applications where the failure of such products would reasonably be expected to result in significant personal injury or death (Safety-Critical Applications) without TRINAMIC's specific written consent.

TRINAMIC products are not designed nor intended for use in military or aerospace applications or environments or in automotive applications unless specifically designated for such use by TRINAMIC. TRINAMIC conveys no patent, copyright, mask work right or other trade mark right to this product. TRINAMIC assumes no liability for any patent and/or other trade mark rights of a third party resulting from processing or handling of the product and/or any other use of the product.

TMCC160-EVAL Document Info

This EVALBOARD User Manual contains only one document, which is the document "EVALBOARD User Manual. Section: Hardware". It is made available to you by TRINAMIC Motion Control GmbH & Co. KG in Hamburg, Germany.

To access other *Datasheets/User Manuals* pertaining to TMCC160, please visit the TMCC160 product page at www.trinamic.com .

Related Documents

The TMCC160 DATASHEET User Manual is related to this product.

Collateral documents

This product documentation comes with additional tool kits, firmware and/or other items, as provided on the specified product page on our company website.

- i** They are made available to you for your convenience but are not part of the *TMCC160- EVALBOARD User Manual* documentation.



REVISION HISTORY

Hardware Product Revision History (HW V.)

Version	Date	Description
1.1	2015-OCT-16	Initial version.

Table 10: Hardware Revision History

▶ Hardware Document Revision History (DC Rev.)

Version	Date	Author/s	Description
1.00	2015-OCT-16	JM/JP/SV	Initial version.
1.01	2016-JAN-04	JP	Format Edits.
1.02	2017-OCT-06	JP	Table 3 lines swapped.

Table 11: Document Revision History

NOTE:

→ Please refer to associated documentation available on product webpage at www.trinamic.com.

REFERENCES

Related Documents and Tools

[TMCC160] TMCC160 Datasheet (please refer to <http://www.trinamic.com>)



TABLE INDEX

Table 1: TMCC160 Order Code..... 1
 Table 2: TMC5031-EVAL Connectors 5
 Table 3: Power Connector 5
 Table 4: Brake Connector 5
 Table 5: Motor Connector 5
 Table 6: Encoder-, Hall-, Reference Switches Connector 6
 Table 7: Interface Connector 7
 Table 8: RS232, RS485 Interface Switch..... 8
 Table 9: General Operational Ratings of the Module 9
 Table 10: Hardware Revision History 15
 Table 11: Document Revision History 15

FIGURE INDEX

Figure 1: TMCC160-EVAL..... 1
 Figure 2 Block Diagram: 1
 Figure 4: TMC160-EVAL Connectors 4
 Figure 5: LEDs 7
 Figure 6: Graphic Overview: Getting Started 11
 Figure 7: TMCC160-EVAL Dimensions..... 12

CLOSING NOTE

© TRINAMIC Motion Control GmbH & Co. KG 2015

Information given in this data sheet is believed to be accurate and reliable. However, neither responsibility is assumed for the consequences of its use nor for any infringement of patents or other rights of third parties, which may result from its use.

Specifications are subject to change without notice.



X-ON Electronics

Largest Supplier of Electrical and Electronic Components

Click to view similar products for [Power Management IC Development Tools](#) category:

Click to view products by [Analog Devices](#) manufacturer:

Other Similar products are found below :

[EVB-EP5348UI](#) [MIC23451-AAAYFL EV](#) [MIC5281YMME EV](#) [124352-HMC860LP3E](#) [DA9063-EVAL](#) [ADP122-3.3-EVALZ](#) [ADP130-0.8-EVALZ](#) [ADP130-1.8-EVALZ](#) [ADP1740-1.5-EVALZ](#) [ADP1870-0.3-EVALZ](#) [ADP1874-0.3-EVALZ](#) [ADP199CB-EVALZ](#) [ADP2102-1.25-EVALZ](#) [ADP2102-1.875EVALZ](#) [ADP2102-1.8-EVALZ](#) [ADP2102-2-EVALZ](#) [ADP2102-3-EVALZ](#) [ADP2102-4-EVALZ](#) [AS3606-DB](#) [BQ25010EVM](#) [BQ3055EVM](#) [ISLUSBI2CKIT1Z](#) [LP38512TS-1.8EV](#) [EVAL-ADM1186-1MBZ](#) [EVAL-ADM1186-2MBZ](#) [ADP122UJZ-REDYKIT](#) [ADP166Z-REDYKIT](#) [ADP170-1.8-EVALZ](#) [ADP171-EVALZ](#) [ADP1853-EVALZ](#) [ADP1873-0.3-EVALZ](#) [ADP198CP-EVALZ](#) [ADP2102-1.0-EVALZ](#) [ADP2102-1-EVALZ](#) [ADP2107-1.8-EVALZ](#) [ADP5020CP-EVALZ](#) [CC-ACC-DBMX-51](#) [ATPL230A-EK](#) [MIC23250-S4YMT EV](#) [MIC26603YJL EV](#) [MIC33050-SYHL EV](#) [TPS60100EVM-131](#) [TPS65010EVM-230](#) [TPS71933-28EVM-213](#) [TPS72728YFFEVM-407](#) [TPS79318YEQEVM](#) [UCC28810EVM-002](#) [XILINXPWR-083](#) [LMR22007YMINI-EVM](#) [LP38501ATJ-EV](#)