

TMCC160 DATASHEET

Integrated motionCookie™ microsystem with 3-Phase BLDC/PMSM gate driver for up to 24V and 1A gate current with a complete servocontroller software stack.



Applications

- Robotics
- Pump, Fan Applications
- Industrial Automation
- Medical, Lab Automation
- CNC Machines
- E-Bikes
- Battery Powered Devices

Features & Benefits

- Integrated BLDC or PMSM Servo Controller
- Integrated Gate Driver up to 1A Gate Current
- Voltage Range 7...24V
- Integrated FOC Controller
- UART, CAN or SPI Interface
- Hall Interface
- ABN Incremental Encoder Interface
- Integrated Switching Regulator

Description

The TMCC160 is a ready to use PMSM/BLDC motor controller in a miniaturized 12x17mm² system in a package. It integrates a powerful programmed microcontroller with efficient state of the art commutation algorithm, gate driver, different interface options as well as a step down converter which generates the digital power supply, measurement and diagnostic features.

Block Diagram

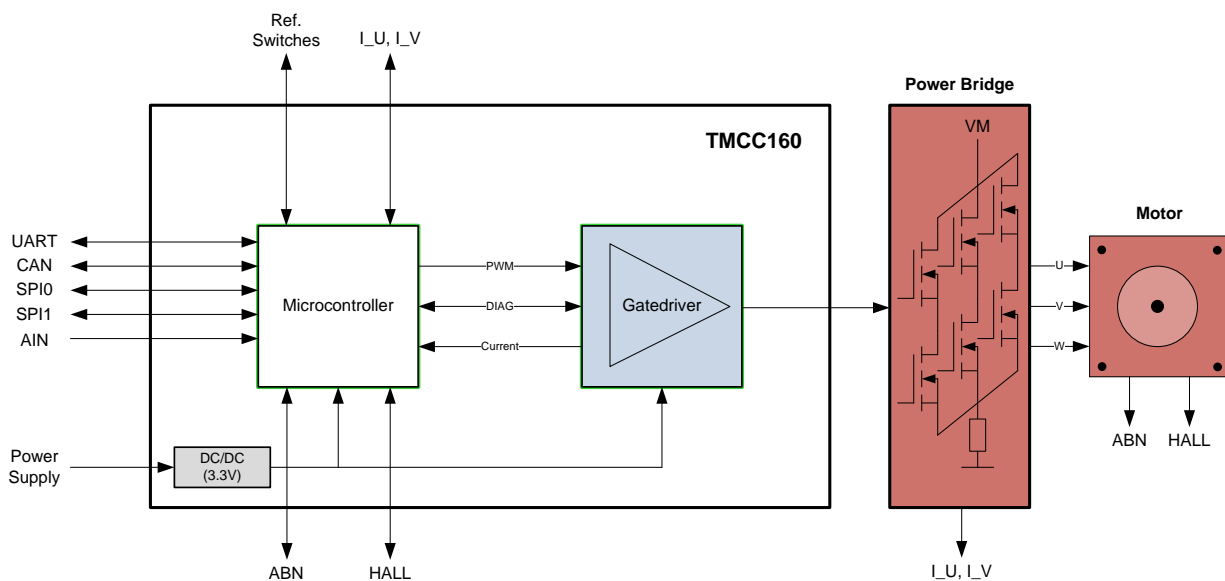

Figure 1: TMCC160 System Block Diagram



1 Table of Contents

TMCC160 DATASHEET	1	4.5.11 Power Supply Filtering Capacitors.....	21
Applications.....	1	4.6 Interface	21
Features & Benefits.....	1	4.6.1 RS232.....	21
Description	1	4.6.2 RS485.....	22
Block Diagram.....	1	4.6.3 RS485 Bus Structure.....	23
1 Table of Contents	2	4.6.4 RS485 Bus Termination.....	23
I PRODUCT DETAILS	1	4.6.5 No Floating Bus Lines.....	23
2 Pin Assignments	1	4.6.6 CAN 2.0B Interface	24
2.1 Package Pin Numbering.....	1	4.6.7 CAN Bus Structure	24
2.2 Package Pin Description.....	2	4.6.8 CAN Bus Termination.....	25
2.3 Wide Range of Control Algorithms	3	4.6.9 Number of Nodes	25
3 System Overview	5	4.6.10 Analog Input	26
3.1 Block Diagram	5	4.7 EEPROM.....	27
3.2 System Architecture.....	5	4.8 Brake Chopper	28
3.3 Hall-Sensor Configuration.....	6	4.8.1 Brake resistor selection	28
3.4 Encoder Configuration	7	4.8.2 Brake Chopper Example.....	29
4 External Components	8	4.9 Absolute Maximum Ratings.....	30
4.1 Gate Driver Charge Pump (TMC6130)	8	5 Operational Ratings	31
4.2 DC/DC Converter (3.3V).....	10	6 Mechanical Dimensions.....	33
4.3 CORTEX M4 Crystal	12	6.1 TMCC160 Package Footprint	33
4.4 Supply Filter	12	6.1.1 Soldering Profile	35
4.5 Power MOSFET Bridge.....	15	7 SUPPLEMENTAL DIRECTIVES.....	36
4.5.1 Direct Coil Current Measurement.....	15	7.1 ESD Sensitive Device.....	36
4.5.2 Recommended Schematic for Direct Coil Measurement	15	7.2 Disclaimer	36
4.5.3 Sense Resistor Selection	16	8 Revision History	37
4.5.4 Calculating Power Losses	17	8.1 Document Revision.....	37
4.5.5 Current Amplifier	17	8.2 Hardware Revision.....	37
4.5.6 Single Shunt Measurement.....	17	8.3 Software Revision	37
4.5.7 Sense Resistor Selection	18		
4.5.8 Dead Time Logic.....	18		
4.5.9 Power MOSFET Selection.....	18		
4.5.10 Gate Driver Clamp Diodes.....	19		



I PRODUCT DETAILS

2 Pin Assignments

TMCC160 has two pad sizes. The pads on the edges measure 0.43mm x 0.43mm with 1mm pitch. The inner pads measure 1.93mm x 1.93mm.

Please refer to chapter [TMCC160 Package Footprint](#) for further information about the package dimensions.

2.1 Package Pin Numbering

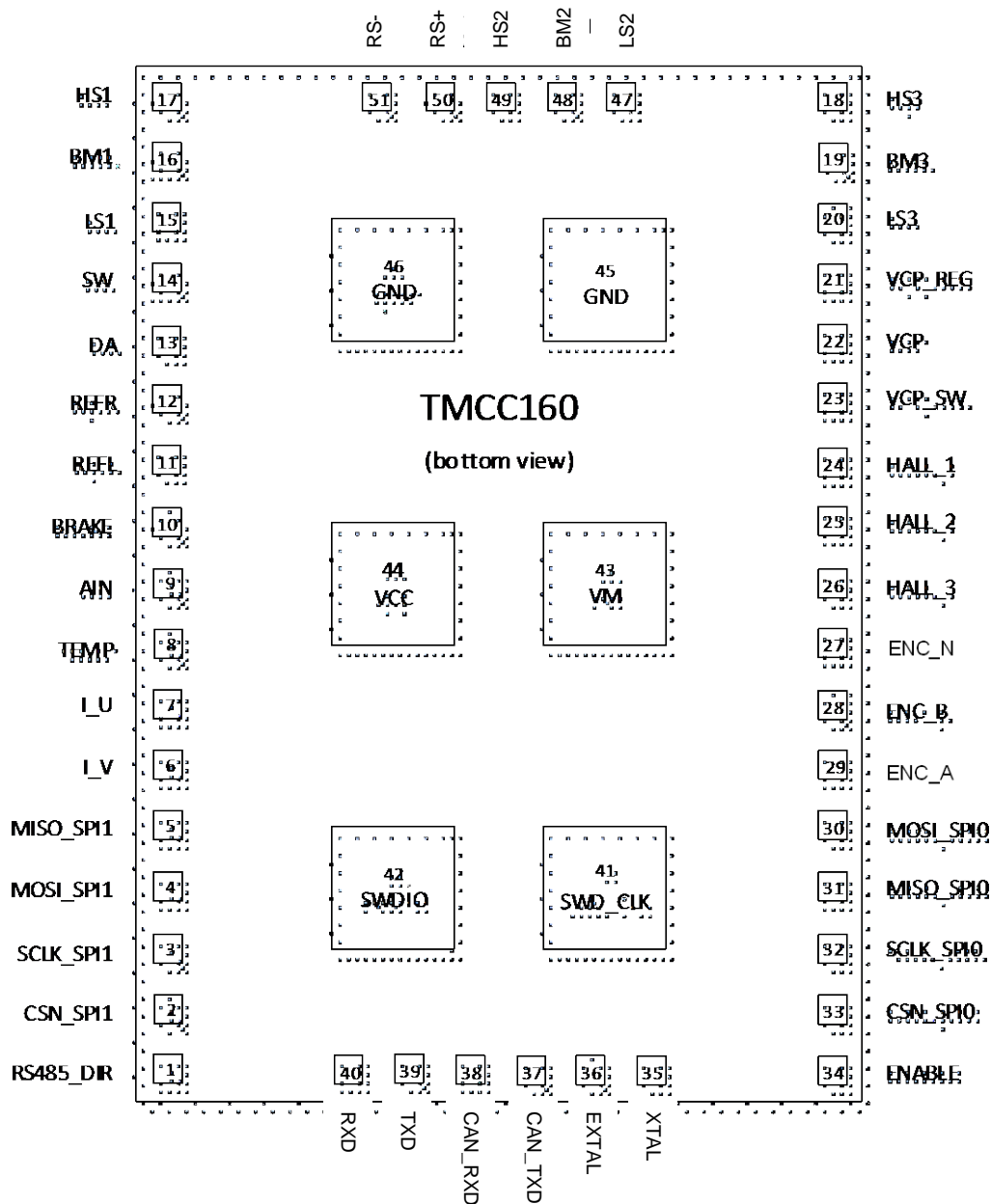

Figure 1 TMCC160 pin assignments / bottom view



2.2 Package Pin Description

Package Pin Description			
Pad Number	Type	Name	Function
1	Out (D)	RS485_DIR	RS485 transceiver direction output.
2	In (D)	CSN_SPI1	SPI1 chip select input (low active) (slave interface).
3	In (D)	SCLK_SPI1	SPI1 serial clock input (slave interface).
4	In (D)	MOSI_SPI1	SPI1 serial input (slave interface).
5	Out (D)	MISO_SPI1	SPI1 serial output (slave interface).
6	In (A)	I_V	Analog current sense amplifier input for PMSM phase V.
7	In (A)	I_U	Analog current sense amplifier input for PMSM phase U.
8	In (A)	TEMP	Analog input for temperature measurement.
9	In (A)	AIN	General purpose analog input.
10	Out (D)	Brake	PWM output for brake chopper circuit.
11	In (D)	REFL	Left reference switch input.
12	In (D)	REFR	Right reference switch input.
13	Out	DA	3.3V switch regulator diode anode.
14	Out	SW	3.3V switch regulator switch cathode.
15	Out	LS1	Low side N-channel MOSFET gate output phase 1 (U).
16	In	BM1	MOSFET bridge output phase 1 (U).
17	Out	HS1	High side N-channel MOSFET gate output phase 1 (U).
18	Out	HS3	High side N-channel MOSFET gate output phase 3 (W).
19	In	BM3	MOSFET bridge output phase 3 (W).
20	Out	LS3	Low side N-channel MOSFET gate output phase 3 (W).
21	Out	VCP_REG	Gate driver linear regulator output. Connect 4.7µF capacitor.
22	In	VCP	Gate driver charge pump input.
23	Out	VCP_SW	Gate driver charge pump output.
24	In (D)	HALL_1	Hall sensor 1 input.
25	In (D)	HALL_2	Hall sensor 2 input.
26	In (D)	HALL_3	Hall sensor 3 input.
27	In (D)	ENC_N	Encoder N (index) input.
28	In (D)	ENC_B	Encoder B input.
29	In (D)	ENC_A	Encoder A input.
30	Out (D)	MOSI_SPI0	SPI0 serial output (EEPROM master).
31	In (D)	MISO_SPI0	SPI0 serial input (EEPROM master).
32	Out (D)	SCLK_SPI0	SPI0 serial clock output (EEPROM master).
33	Out (D)	CSN_SPI0	SPI0 chip select output (low active) (EEPROM master).
34	IO (D)	ENABLE	Motor driver enable (high active). ENABLE signal is also connected to the internal µC. Please connect ENABLE pin only to open drain outputs.
35	Out	XTAL	Crystal oscillator output.
36	In	EXTAL	Crystal oscillator input.
37	Out (D)	CAN_TXD	CAN interface output. Connect to CAN transceiver.



Package Pin Description			
Pad Number	Type	Name	Function
38	In (D)	CAN_RXD	CAN interface input. Connect to CAN transceiver.
39	Out (D)	TXD	UART output. Connect to RS232/RS485 transceiver.
40	In (D)	RXD	UART input. Connect to RS232/RS485 transceiver.
41	In (D)	SWDCLK	Please do not connect.
42	IO (D)	SWDIO	Please do not connect.
43		VM	Motor supply voltage.
44	In	VCC	3.3V digital supply voltage.
45		GND	System ground connection.
46		GND	System ground connection.
47	Out	LS2	Low side N-channel MOSFET gate output phase 2 (V).
48	In	BM2	MOSFET bridge output phase 2 (V).
49	Out	HS2	High side N-channel MOSFET gate output phase 2 (V).
50	In (A)	RS+	Positive current sense input for single shunt measurement.
51	In (A)	RS-	Negative current sense input for single shunt measurement.

Table Key: (D): digital IO, (A): analog IO



2.3 Wide Range of Control Algorithms

The TMCC160 is a ready to use PMSM/ BLDC motor controller in a miniaturized 12x17mm² package. It integrates a powerful programmed microcontroller with efficient state of the art commutation algorithm, gate driver, measurement and diagnostic features, different interface options as well as a step down converter which generates the digital power supply.

TMCC supports FOC and six-step mode

TMCC160 supports state of the art field oriented control algorithm (FOC) using hall or encoder signals for PMSM motors as well as block hall commutation (six step mode) for BLDC motors. Current-, velocity- and position controller are implemented for all commutation modes. They can be parameterized via the installed TMCL protocol.

Scope of TMCL Operating System

Only few external hardware components are needed to build a complete servo drive without spending time developing complicated control and communication software. With the programmed operating system, TMCL, it is possible to directly connect a host PC to the TMCC160 via one of the supported interface connections. All parameters for motion control and global functions can be configured by only reading or writing registers.

- i Software customization and custom package labeling are available upon request.



3 System Overview

3.1 Block Diagram

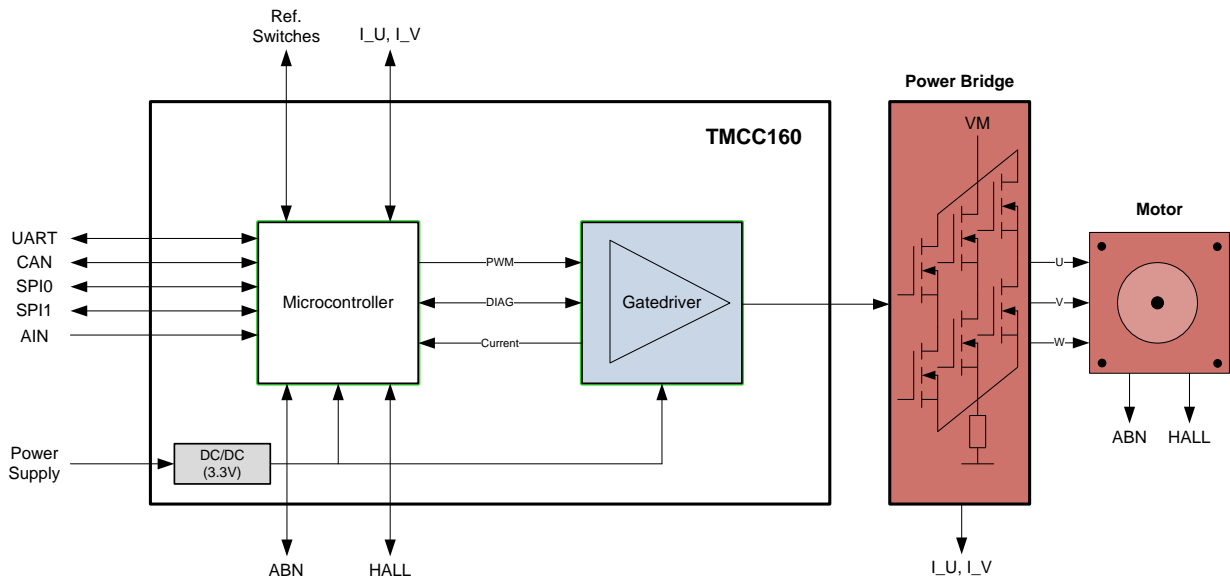

Figure 2: TMCC160 System Block Diagram

3.2 System Architecture

Only a few external components are needed to build a complete closed-loop system with maximum flexibility. To interconnect TMCC160 with a host PC or microcontroller, the following interfaces are available: UART(RS232, RS485), CAN, SPI. An analog input supports simple standalone applications.

Avoiding Power Overshoots

To avoid power supply overshoots during deceleration/ energy feedback from the motor, TMCC160 provides a brake chopper output which can be connected to a low side N-channel MOSFET. The brake chopper duty cycle will be automatically controlled depending on the supply voltage.

TMCL storage in external EEPROM

TMCL programs can be stored in an external EEPROM. Programs can be automatically executed after power up or triggered from the host system.



3.3 Hall-Sensor Configuration

For applications with reduced requirements concerning positioning accuracy and low speed behavior a hall-sensor configuration is the most cost efficient option. Most BLDC/ PMSM motors already include hall-sensors for commutation.

TMCC160 Block Diagram in Hall-Sensor Configuration

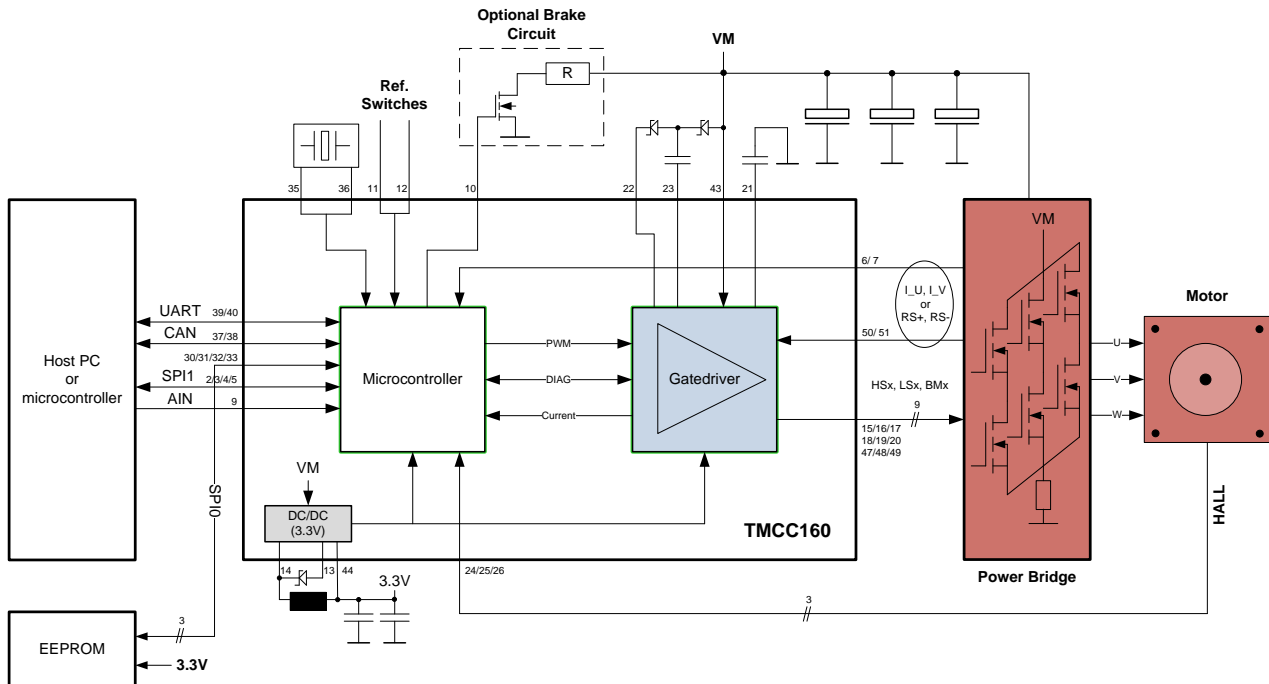

Figure 3: TMCC160 Hall-Sensor Block Diagram

Special Areas of Concern



Depending on the used motor, the customer can use a direct coil current measurement with external current sensors for field oriented control; typically used for Permanent Magnet Synchronous Motors (PMSM) or single shunt measurement if block hall/six step mode is configured in TMCC160 software (typical used for Brushless DC motors, BLDC).



3.4 Encoder Configuration

For applications which requires high positioning accuracy and a smooth run at low speed a motor with encoder is mandatory. TMCC160 supports incremental ABN encoders with a resolution of up to 16000 lines. Additional hall-sensors or encoder N-channel can be used for encoder initialization after power up.

TMCC160 Block Diagram in Encoder Configuration

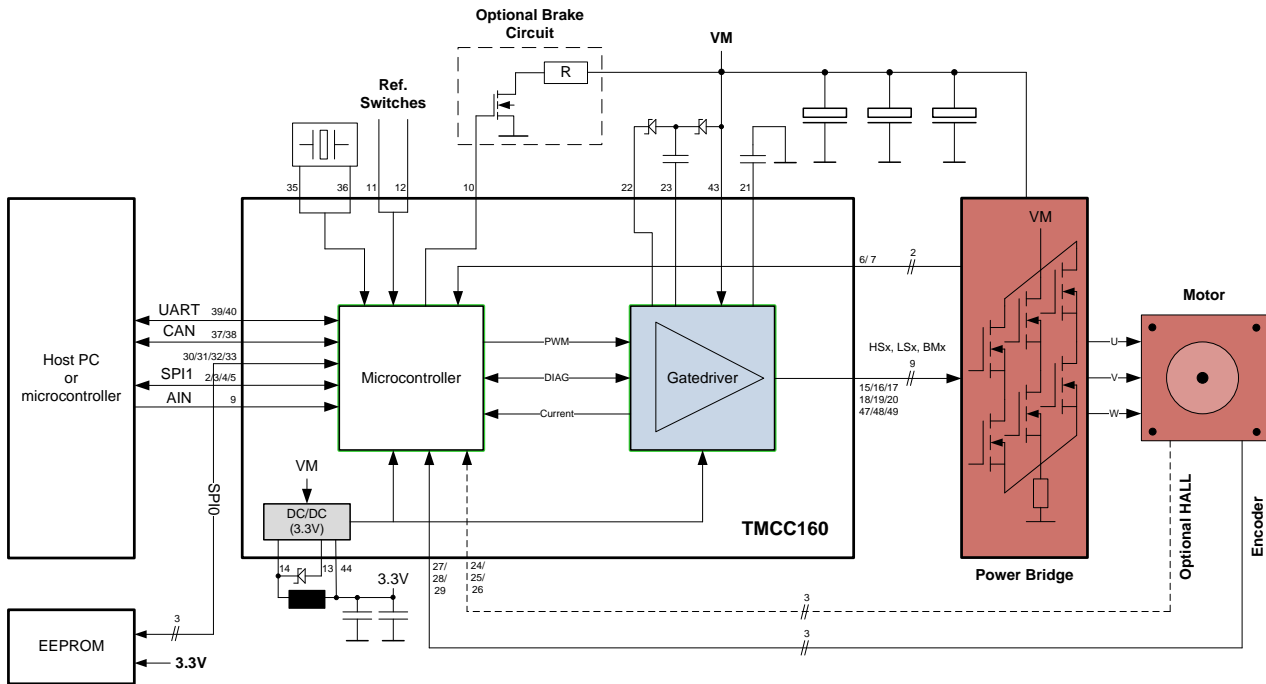

Figure 4: TMCC160 Encoder Block Diagram

- i If encoder configuration is used motor will be controlled by field oriented control, FOC.



4 External Components

4.1 Gate Driver Charge Pump (TMC6130)

For the external N-channel power MOSFET bridge, TMCC160 generates a 12V gate source voltage for high and low side MOSFETs (N-channel). The gate source voltage will also be maintained if the supply voltage falls below 12V. External component example is shown in schematic below. Buffer capacitor for charge pump linear regulator (C3) should not be smaller than 4.7µF.

If the supply voltage does not fall below 12V charge pump circuitry can be left away without performance loss (connect VCP to VM, omit D1, D2, C2, VCP_SW not connected).

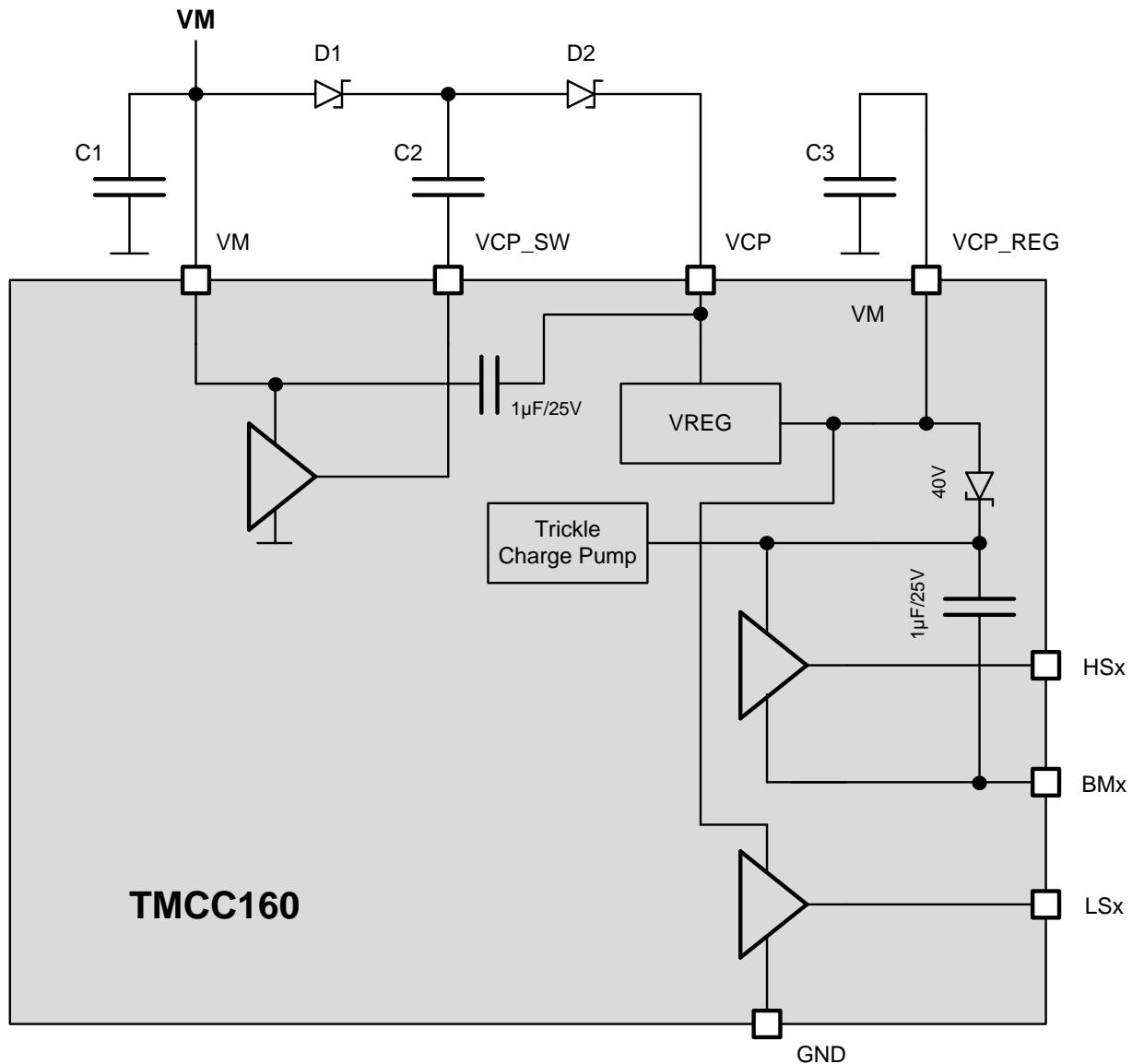

Figure 5: Charge Pump Example Schematic

- i A component list example is provided on the next page.



Charge Pump Component List Example			
COMPONENT	DESCRIPTION	VENDOR	ORDER CODE
C1	2 X 4.7µF/35V ceramic capacitor	Murata Electronics	GRM219R6YA475MA73D
		TDK	C2012X7R1V475K125AC
C2	33nF/50V ceramic capacitor	Multicomp	MC0603B333J500CT
		AVX Corporation	06035C333JAT2A
C3	4.7µF/25V ceramic capacitor	Kemet	C0805C475K3PACTU
		Murata Electronics	GRM21BR61E475KA12L
		TDK	CGA4J1X7R1E475K125AC
D1, D2	60V/1A	Vishay	MSS1P6 (assembled on EVAL board)

Table 1: Charge Pump Component List Example



4.2 DC/DC Converter (3.3V)

The 3.3V digital supply is generated with an internal step down switch regulator from VM. The step down converter works with a PWM frequency of 2.2MHz and supports a maximum output current of 500mA. A collection of external components like coils and diodes are listed below. Equivalent components can be used. The 3.3V can also be used to supply further external components like current-, hall sensors etc. if the consumption does not exceed 400mA.

NOTE:

→ Place D1, L1, C1-C2 close to the TMCC160 pins SW, DA and VCC

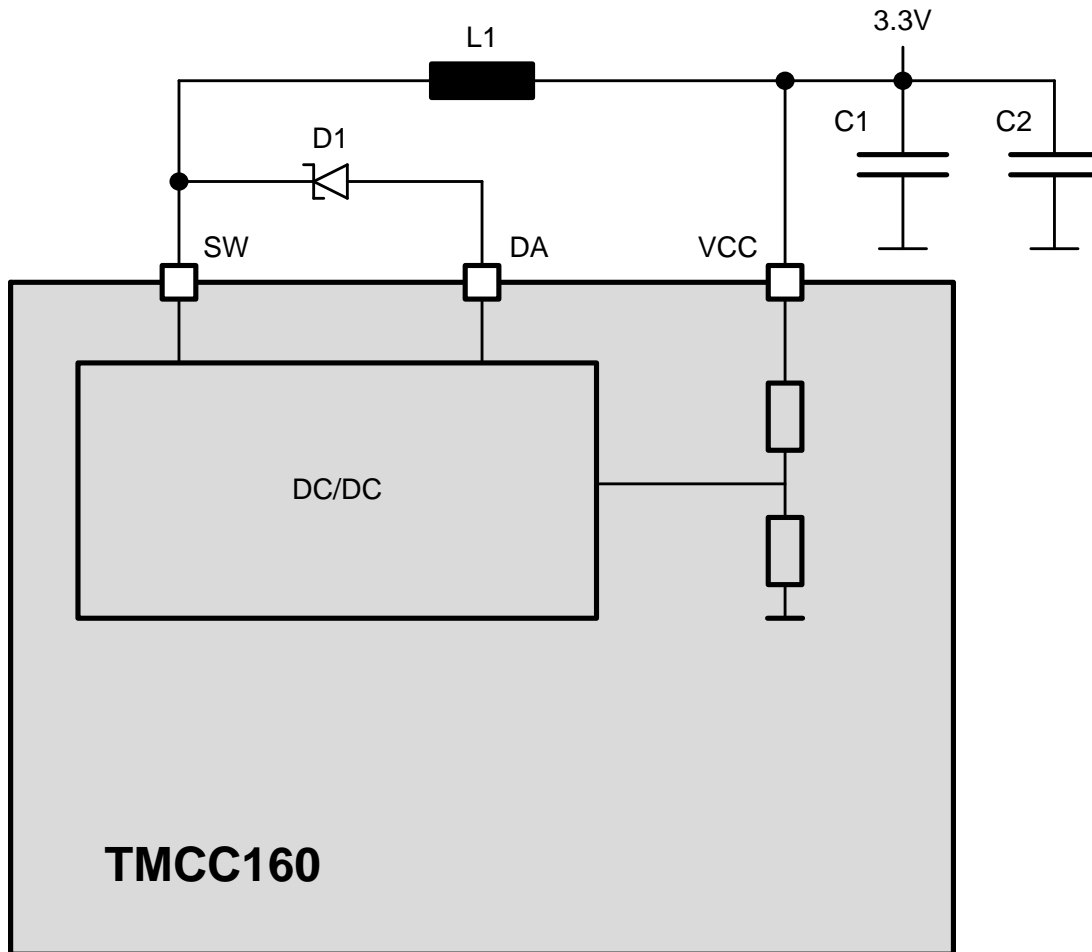

Figure 6: DC/DC Converter Example Schematic



DC/DC Component List Example			
COMPONENT	DESCRIPTION	VENDOR	Series
C1	100nF/16V ceramic capacitor		
C2	10µF/16V ceramic capacitor		
L1	6.8µH/700mA	Murata Electronics	LQH43C (assembled on EVAL board)
		Würth Elektronik	WE-TPC, WE-PD2
		Toko	A916CY
D1	40V/500mA low capacitance	Vishay	MSS1P6 (assembled on EVAL board)
		Diodes Inc.	SBR1U40LP
		ON Semi	MBRM140
		Diodes Inc.	DFLS140

Table 2:DC/DC Component List Example



4.3 CORTEX M4 Crystal

For system clock generation an external crystal is mandatory. As default, a crystal with 16MHz frequency and a frequency stability of $\pm 50\text{ppm}$ should be used. Crystal frequency can be modified for customized firmware versions. Load capacitors C1, C2 depends on the used crystal. Values are typically in a range of 8-22pF.

NOTE:

→ Place C1-C2, Q1 close to the TMCC160 pins

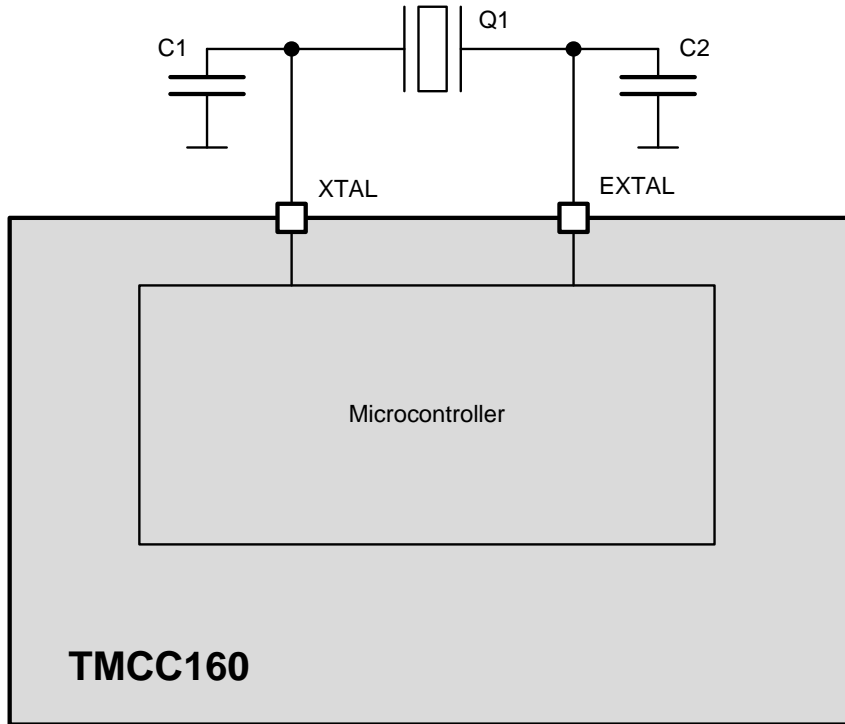

Figure 7: Crystal Example Schematic

Crystal Component List Example			
COMPONENT	DESCRIPTION	VENDOR	Series
C1	15pF/50V ceramic capacitor		
C2	15pF/50V ceramic capacitor		
Q1	16MHz crystal	NDK	NX3225SA

Table 3: Crystal Component List Example

4.4 Supply Filter

To ensure proper operation VM and 3.3V supply voltage must be stable. TMCC160 already includes small buffer capacitors to stabilize the supply voltages. Nevertheless are additional capacitors mandatory.

NOTE:



→ Place C1 -C4 close to the TMCC160 pins VCC and VM.

Configuration for step down converter output

For a step down converter output current of 500mA a minimal total capacity of 10µF (C1 + C2) should be selected.

- i** VM should be stabilized with minimum 2pcs. 4.7µF ceramic capacitors.

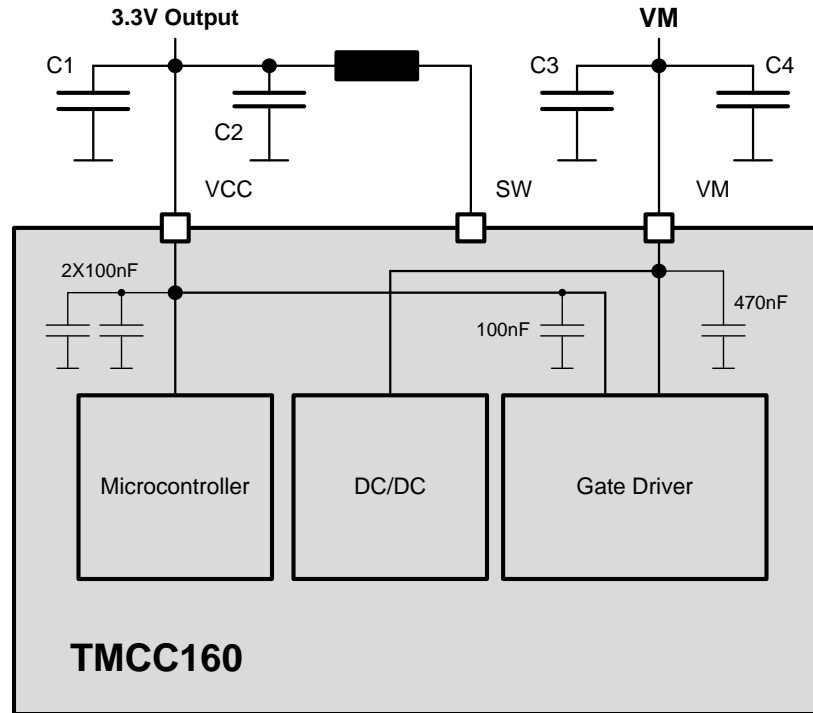

Figure 8: Supply Filter Example Schematic



Supply Filter Component List Example			
COMPONENT	DESCRIPTION	VENDOR	Series
C1	100nF/16V ceramic capacitor		
C2	10µF/16V ceramic capacitor		
C3	4.7µF/35V ceramic capacitor	Murata Electronics	GRM219R6YA475MA73D
		TDK	C2012X7R1V475K125AC
C4	4.7µF/35V ceramic capacitor	Murata Electronics	GRM219R6YA475MA73D
		TDK	C2012X7R1V475K125AC

Table 4: Supply Filter Component List Example



4.5 Power MOSFET Bridge

TMCC160 provides a powerful gate driver for a three phase bridge using N-channel MOSFETs only. The system is capable to drive MOSFETs with up to 350nC gate charge. The gates of the MOSFETs will be charged with a current of $\pm 1A$. This helps to reduce dynamic losses and to building high efficient systems in a wide power range.

4.5.1 Direct Coil Current Measurement

A power MOSFET schematic including two phase direct coil current amplifier (e.g. AD8418) is shown below. The coil current measurement amplifiers can be powered by the 3.3V supply of the TMCC160.

NOTE:

→ Integrate coil current amplifiers in motor coil connection U and V.

4.5.2 Recommended Schematic for Direct Coil Measurement

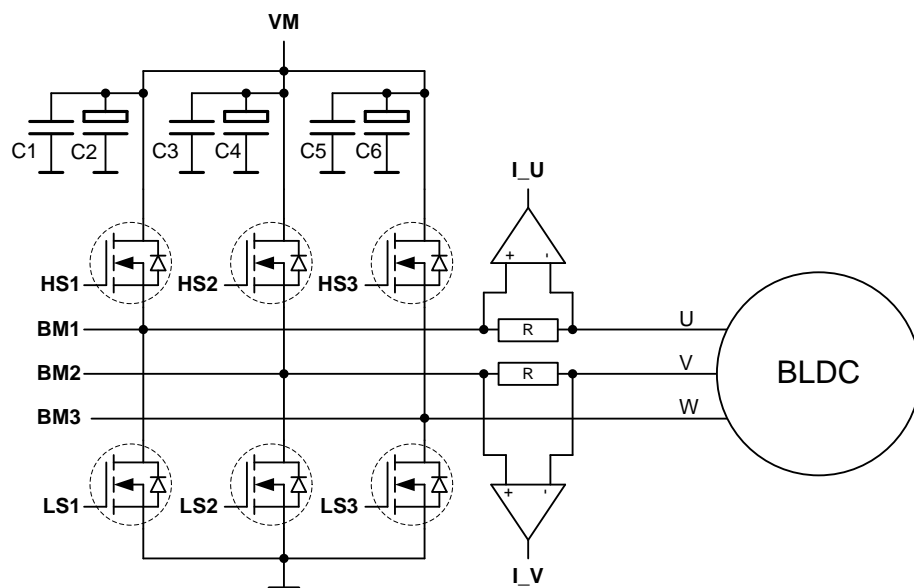

Figure 9: Direct Coil Current Measurement Schematic

- i Direct coil current measurement is recommended for field oriented control (FOC) in hall- or encoder mode. It can also be used in block hall commutation (six step mode).

NOTE:

→ Please note that the current amplifier has to be configured for bidirectional measurement. A sample schematic for direct coil current measurement with AD8418 is published in the TMCC160-EVAL board schematic.

Current Sense Inputs

The input voltage range of the TMCC160 current sense inputs I_U, I_V is 0..VCC. Both signals will be routed to the TMCC160 microcontroller and converted with a resolution of 12 bits. For a symmetric motor current measurement in positive and negative direction, the current amplifier must output VCC/2 at zero motor current to meet the TMCC160 offset configured.

NOTE:



→ Keep a safety margin for the current control of about 10% in order to avoid reaching the internal TMCC160 ADC limits. This margin shall be respected for the current limit setting.

TMCC160 Direct Coil Current Signal Example

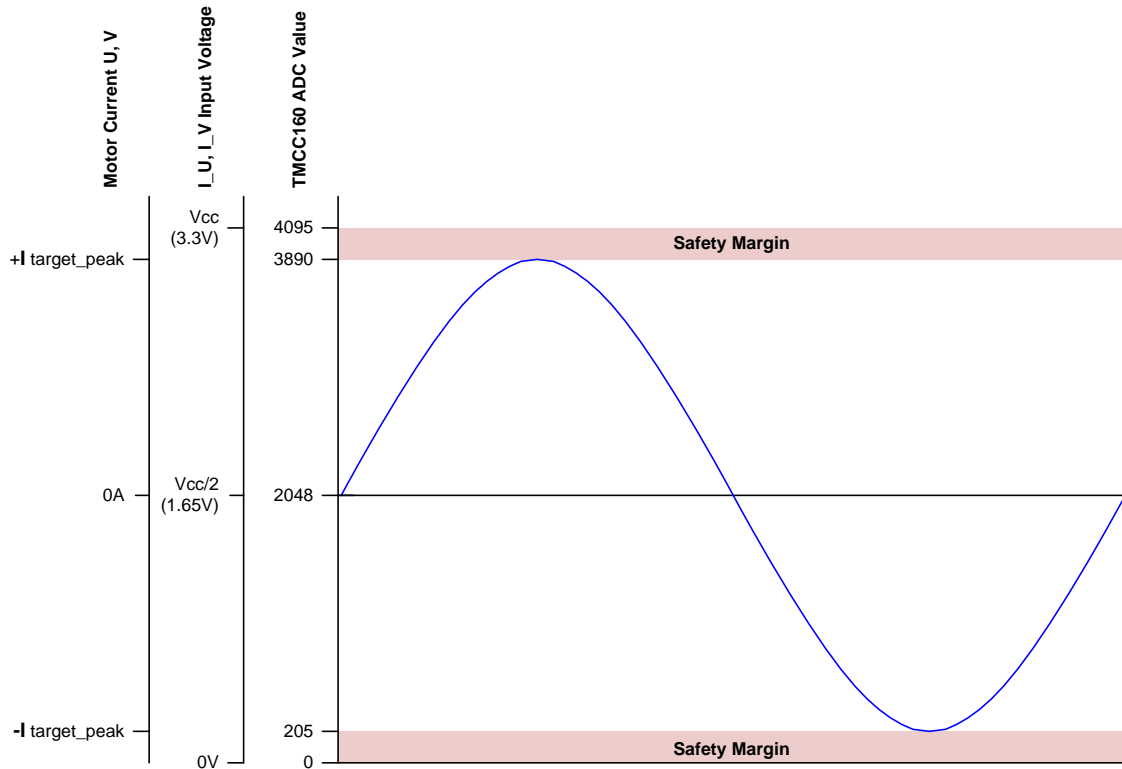

Figure 10: Direct Coil Current Signal Example

4.5.3 Sense Resistor Selection

Use formula below to calculate the sense resistors for direct coil current measurement.

$$R_{Sense} = \frac{\frac{1.48V}{G}}{I_{target_peak}} = \frac{\frac{1.48V}{G}}{\sqrt{2} * I_{target_RMS}} \quad (G = \text{Current Amplifier Gain})$$

G=20 (AD8418)

Formulae 1: Direct Coil Current Sense Resistor Calculation



4.5.4
Calculating Power Losses

The power losses which are generated in the sense resistor can be calculated with formula below.

$$P_{Sense} = I_{target_RMS}^2 * R_{Sense} = (I_{target_peak}/\sqrt{2})^2 * R_{Sense}$$

Formulae 2: Direct Coil Current Sense Resistor Losses

4.5.5 Current Amplifier

Current Amplifier			
COMPONENT	DESCRIPTION	VENDOR	Series
	AD8418	ANALOG DEVICES	
	AD8206	ANALOG DEVICES	

4.5.6
Single Shunt Measurement

The single shunt measurement uses only one resistor in the bottom GND connection of the power MOSFET bridge. TMCC160 supports a high speed, high bandwidth, and low offset current sense amplifier with configurable input range for signal conditioning.

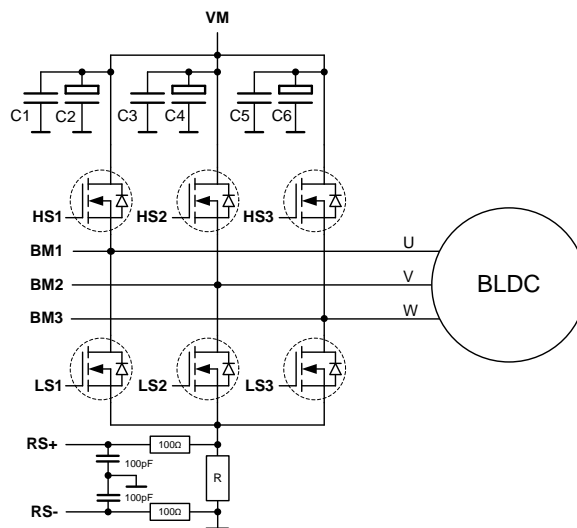

Figure 11: Single Shunt Measurement Schematic

NOTE:

→ Single shunt measurement is only possible for block hall (six step mode) commutation.



- A low pass with cut off frequency of approximately 16MHz should be placed on TMCC160 input RS+, RS- to filter high frequency.
- Place RC low pass close to the TMCC160.

4.5.7 Sense Resistor Selection

Gain of the internal current sense amplifier can be configured by software. Following gain values are available:

Gain values: 8/ 10.3/ 13.3/ 17.2/ 22.2/ 28.7/ 37/ 47.8

The accuracy of the amplifier is ±3%. The maximum input voltage between RS+ and RS- depends on the configured amplifier gain:

$$U_{Max} = \frac{1.48V}{Gain}$$

Formulae 3: Maximum Input Voltage Calculation

With the given U_{Max} it is possible to calculate the sense resistor for a given maximum target current. Calculation formula for R_{Sense} is given below. The maximum current can be measured in both directions depending on the power MOSFET state.

$$R_{Sense} = \frac{\frac{1.48V}{Gain}}{I_{target_peak}}$$

Formulae 4: Single Shunt Sense Resistor Calculation

4.5.8 Dead Time Logic

To protect each half bridge against cross-conduction during switching high- and low-side MOSFETs, TMCC160 includes a programmable dead time delay between high- and low-side MOSFET of the same phase. During the dead time high- and low-side MOSFETs are off. The dead time can be configured in software.

Dead time:

0.00µS/ 0.51µS/ 0.80µS/ **1.10µS**/ 1.67µS/ 2.30µS/ 3.40µS/ 6.9µS

- i** To avoid high losses during switch event a proper dead time adaption is needed. A value of 1.1µS is a good start value for further tuning.

4.5.9 Power MOSFET Selection

TMCC160 provides an integrated 3-phase gate driver for pure N-channel MOSSFET bridge. The gate driver is capable to drive the high- and low-side gate with up to 1A source, sink. This allows fast and high efficient switching of power MOSFETs with a gate charge up to 350nC. To drive the high- and low-side MOSFETs down to a supply voltage of 7V a charge pump is integrated. Gate-source voltage of high- and low-side gate driver output is 12V.

The duration of the switching event depends on the total gate charge of the MOSFET and can be calculated with the formula below.



$$t_{slope} = \frac{Q_{Miller}}{\pm 1A}$$

Formulae 5: MOSFET Switch Slope Calculation

Diagram: MOSFET Parameters During Switch Event

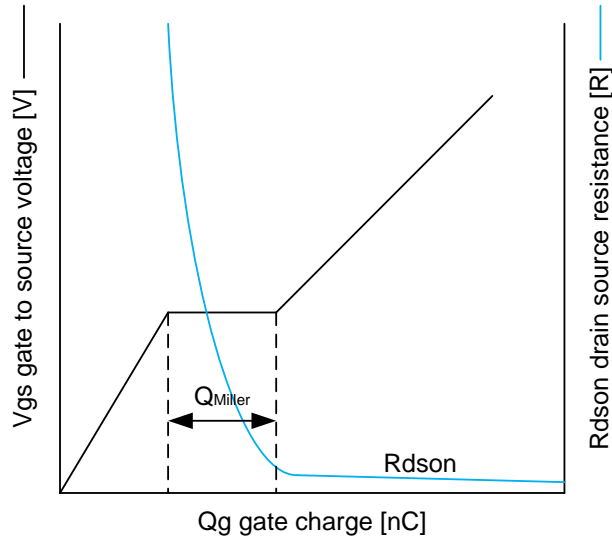

Figure 12: MOSFET Parameters During Switch Event

4.5.10 Gate Driver Clamp Diodes

To avoid that negative voltage spikes (high frequency oscillation) reach the TMCC160 gate driver output pins during switch events, high- and low-side gate series resistors (R) as well as optional clamp diodes (D) on low-side gate output are recommend.

The negative voltage oscillation roots from the recovery effect of the MOSFETs body diodes during switching. A clamp circuit for BMx pins is integrated in the TMCC160.

Depending on the gate charge, the following gate series resistors are recommended:

Gate Charge Resistors Table		
GATE CHARGE:	MIN GATE SERIES RESISTOR [Ω]:	LOW SIDE CLAMP DIODE:
<50nC	10R	optional
50..100nC	4.7R	recommended
>100nC	2.2R	required

Table 5: Gate Charge Resistor and Clamp Diode Recommendation

NOTE:

→ Values in table above have to be validated in layout.



→ *It is important to place the clamp diode close to LSx pin.*



Diagram

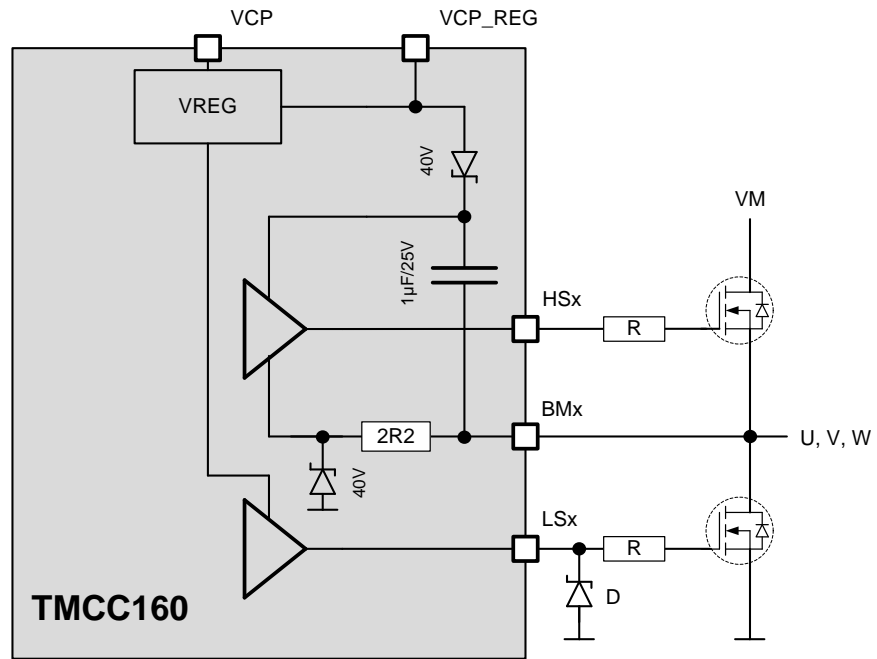

Figure 13: Gate Charge Resistor and Clamp Diode Example Schematic

4.5.11 Power Supply Filtering Capacitors

To ensure stable power supply voltage, please ensure that enough power supply filtering capacitors are available in the system to absorb kinetic energy during deceleration and load control. Additionally, a regulated power supply is recommended, especially if the system is operated close to the maximum supply voltage or a long power supply line is used.

For power supply filtering capacitor value, the following rule of thumb can be used to calculate the system capacity (depending on the motor velocity I_{Supply} varies between 10% to 100% of the motor current):

$$C_{Filter} = 1000\mu F * I_{Supply}$$

- i To reduce power losses in the capacitors and increase voltage stability use low ESR-capacitor type.

4.6 Interface

The TMCC160 system in a package supports RS232, RS485, CAN and SPI interface as well as an analog input which can be used for control and parameterization.

4.6.1 RS232

For easy intercommunication with a microcontroller or a host PC TMCC160 system in a package provides a 3.3V UART interface which can be directly connected to a microcontroller UART (3.3V TTL level) or connected to an external RS232 transceiver supporting a full RS232 signal interface.



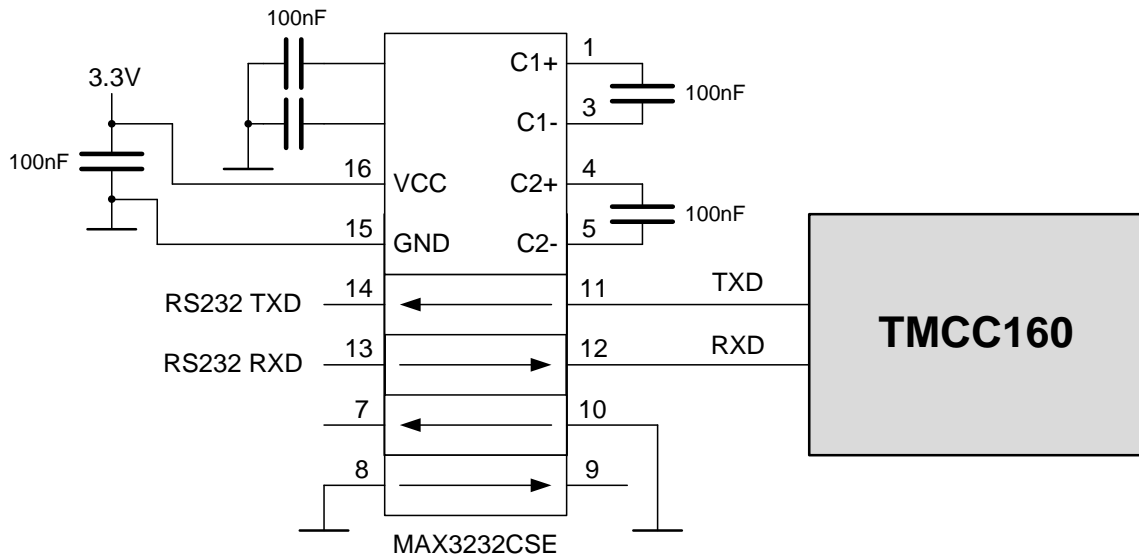

Figure 14: RS232 Interface Example Schematic

NOTE:

→ Circuit above shows an example of a RS232 interface configuration with external transceiver powered by the TMCC160 internal generated 3.3V supply voltage. Circuit above only shows an example, many other RS232 transceivers are available.

**4.6.2
RS485**

For remote control and host communication the TMCC160 provides a two wire RS485 bus interface. An external RS485 transceiver is required to integrate the TMCC160 into a RS485 bus structure. An example circuit is shown below, several other RS485 transceivers are available.

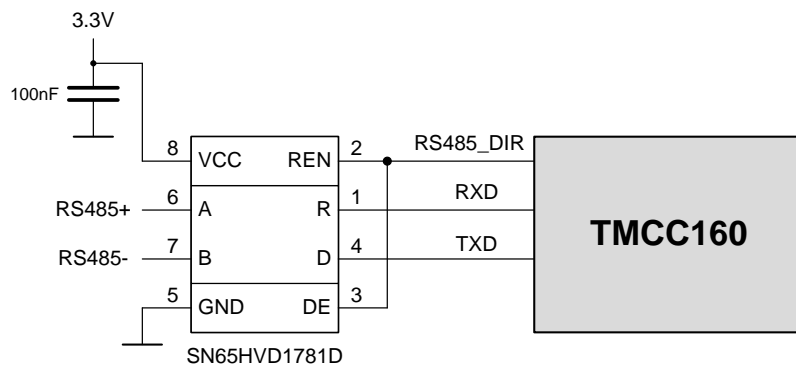

Figure 15: RS485 Interface Example Schematic

NOTE:

→ TMCC160 is capable to supply a RS485 transceiver with the internal 3.3V power supply.
 → For a proper RS485 operation following items should be taken into account when setting up an RS485 network:



4.6.3
RS485 Bus
Structure

The network topology should follow a bus structure as closely as possible. That is, the connection between each node and the bus itself should be as short as possible. Basically, it should be short compared to the length of the bus.

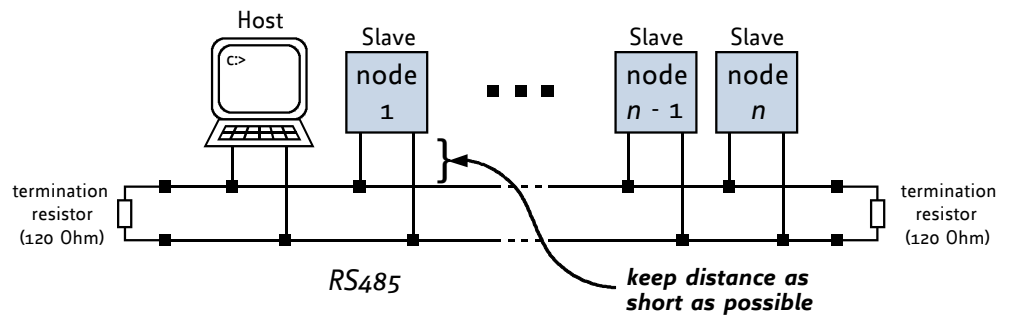

Figure 16: RS485 Bus Interface Structure

4.6.4
RS485 Bus
Termination

Especially for longer busses and/or multiple nodes connected to the bus and/or high communication speeds, the bus should be properly terminated at both ends. Therefore, a 120 Ohm termination resistors at both ends of the bus have to be added.

4.6.5
No Floating Bus
Lines

Avoid floating bus lines while neither the host/master nor one of the slaves along the bus line is transmitting data (all bus nodes switched to receive mode). Floating bus lines may lead to communication errors. In order to ensure valid signals on the bus it is recommended to use a resistor network connecting both bus lines in order to define logic levels appropriately.

Two configuration options can be recommended. They are explained on the next page.

Configuration
Option 1

Add resistor (Bias) network on **one** side of the bus, only (120R termination resistor still at **both** ends):

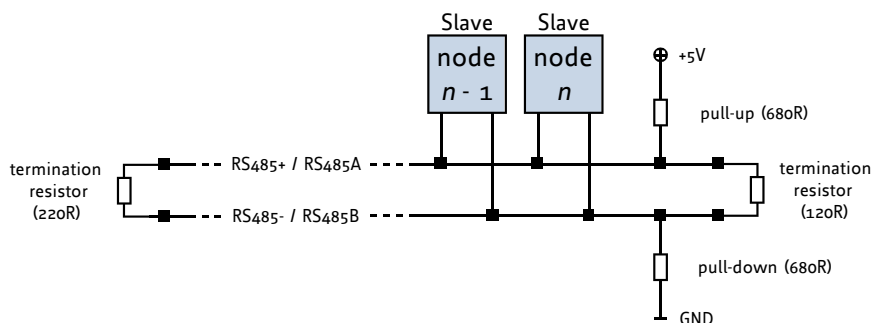

Bus lines with resistor (Bias) network on one side, only

Configuration
Option 2

Or add resistor (bias) network at both ends of the bus (like Profibus™ termination):



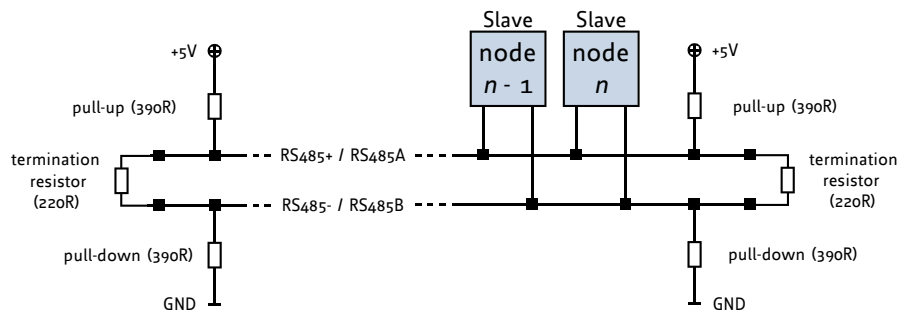

Figure 17: Bus lines with resistor (Bias) network at both ends

Certain RS485 interface converters available for PCs already include these additional resistors (e.g. USB-2-485 with bias network at one end of the bus).

4.6.6
CAN 2.0B Interface

TMCC160 supports a full CAN 2.0B interface with up to 1Mbit/s. An external CAN transceiver is needed to integrate TMCC160 into a CAN bus network. It is possible to use TMCC160 internal generated 3.3V supply to power the IO voltage of a CAN transceiver like in picture below.

4.6.7
CAN Bus Structure

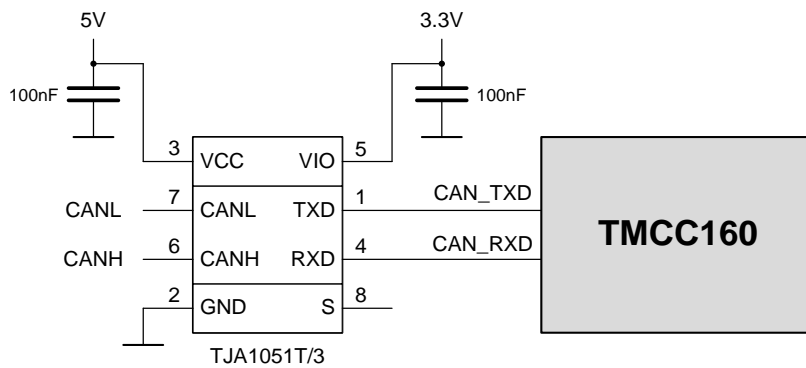

Figure 18: CAN Interface Example Schematic

NOTE:

→ The network topology should follow a bus structure as closely as possible. The connection between each node and the CAN bus itself should be as short as possible to avoid signal reflections.

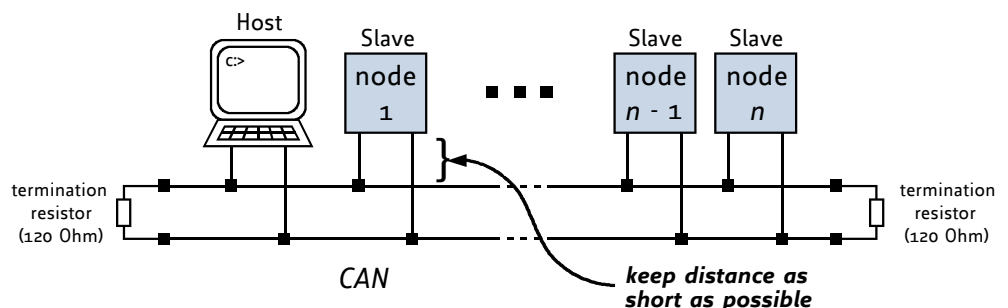

Figure 19: CAN Bus Structure



4.6.8
CAN Bus
Termination

CAN bus must be properly terminated at both ends with a resistor of 120R between CANH, CANL signal.

4.6.9
Number of Nodes

TMCC160 software supports CAN addresses up to 0x7FF (2047) but the maximum number of nodes highly depends on the used transceiver and the bus structure itself.

- i Please see datasheet of used CAN transceiver for maximum number of CAN nodes.



4.6.10 Analog Input

The analog input signal of the TMCC160 can be used as a target value to e.g. control torque, velocity or other parameters. The analog input voltage is routed directly to the TMCC160 μC and will be converted with a resolution of 12 bit. AIN is designed for a voltage range between 0 and V_{CC} (3.3V). For higher voltages use a voltage divider plus optional protection diode as in example below.

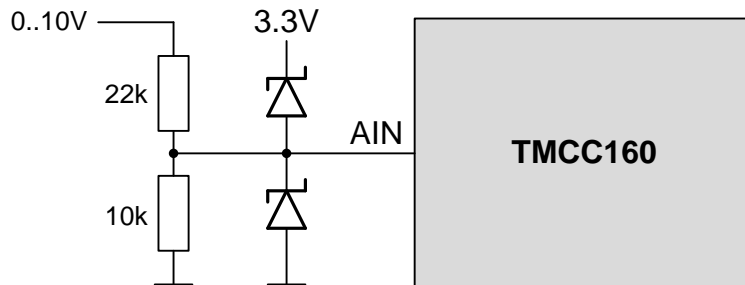

4.7 EEPROM

To store and execute TMCL programs a EEPROM is needed. Interconnection between TMCC160 and EEPROM is done via SPI_0 interface. To ensure compatibility between TMCC160 default firmware and EEPROM, please use dedicated Atmel EEPROM listed below. It is possible to use TMCC160 internal generated 3.3V supply to power the EEPROM.

EEPROM Connection Schematic

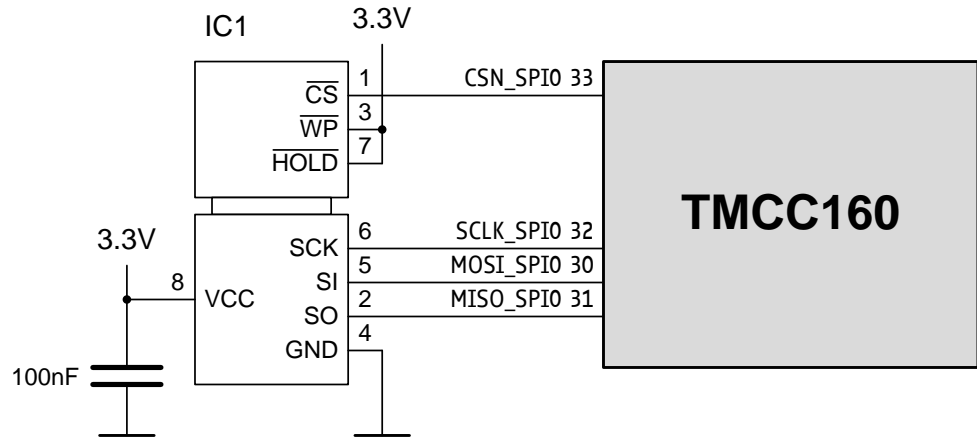

Figure 20: EEPROM Connection Schematic

COMPONENT	DESCRIPTION	VENDOR	Series
	AT25128B-SSHL	Atmel	



4.8 Brake Chopper

A servo system feeds back energy to the power supply line during deceleration and load control. The energy can lead to a voltage rise on the power supply system if it is not dissipated. The voltage overshoot of a system without brake chopper depends on the motor deceleration time, kinetic energy and the servo module buffer capacity. The brake chopper dissipates this energy from the system, and thus avoids system damage.

Brake Chopper Output

TMCC160 provides a continuous motor voltage monitoring (20kHz) as well as a brake chopper output. The brake chopper output pin is controlled from a comparator implemented in TMCC160 software. Voltage threshold, hysteresis, enable/ disable is configurable via software.

Motor voltage should be limited to 90% - 95% of the maximum possible operation voltage.

Brake Chopper Example Schematic

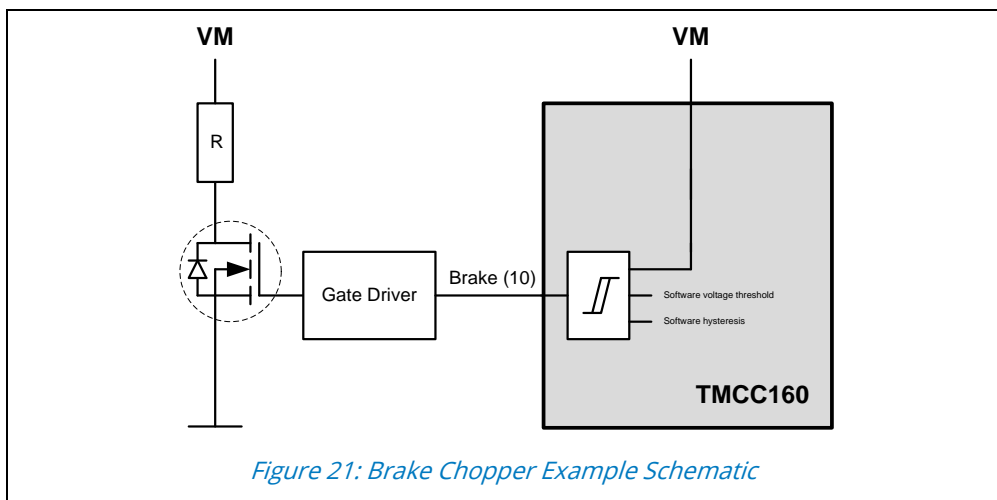

Figure 21: Brake Chopper Example Schematic

4.8.1 Brake resistor selection

For a full speed ramp stop, the brake resistor should be able to dissipate the complete kinetic energy which is fed back during deceleration ramp (t_{dec}).

Kinetic energy:

$$E_{Kin} = \frac{1}{2} * J * \omega_{max}^2. [J = \text{moment of inertial}, \omega = \text{angular speed}]$$

Deceleration time:

$$t_{dec}.$$

Electrical energy:

$$E_{Elec.} = P * t_{dec.} = \frac{(U_{supply})^2}{R} * t_{dec.}$$

Brake resistor:

$$R_{Brake} = \frac{(U_{supply})^2 * t_{dec.}}{E_{Kin}}$$

Formulae 6: Brake Chopper Resistor Calculation



4.8.2
Brake Chopper
Example

The figure below shows brake chopper in operation. The supply voltage threshold is configured at approximately 26V. The yellow line represents the supply voltage of the TMCC160.

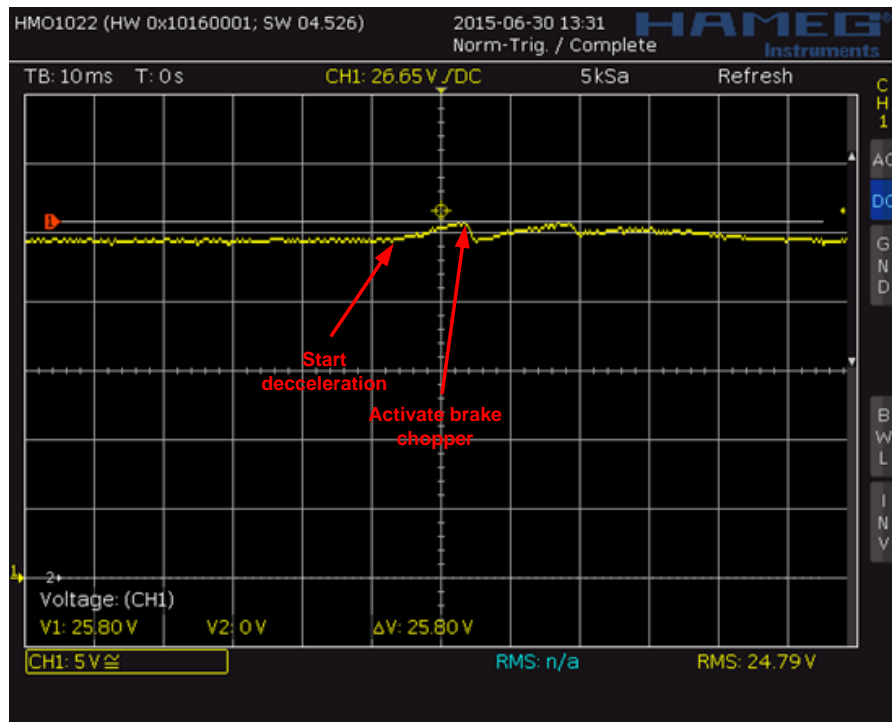

Figure 22: Supply Voltage Monitoring (Activated Brake Chopper)



4.9 Absolute Maximum Ratings

NOTE:

→ The maximum values must NOT be exceeded; under no circumstance.

Absolute Maximum Ratings					
Parameter	SYMBOL	MIN	TYP	MAX	Unit
Supply voltage, t<200ms	VM	-0.3		35	V
Logic supply voltage	VCC	-0.3		3.8	V

Table 6: TMCC160 Absolute Maximum Ratings



5 Operational Ratings

The operational ratings show the intended - or the characteristic - ranges and should be used as design values.

NOTE:

→ The maximum values must NOT be exceeded; under no circumstance.

Operational Ratings					
Parameter	SYMBOL	MIN	TYP	MAX	Unit
Supply voltage	VM	7V	24	28	V
Logic supply voltage	VCC	3.0	3.3	3.6	V
Logic					
Logic input voltage	V _I	-0.3		VCC+0.3	V
Logic input high	V _{IH}	0.7*VCC			V
Logic input low	V _{IL}			0.35*VCC	
Analog input voltage (pin: I_V, I_U, TEMP, AIN)	V _{IA}	-0.3		VCC+0.3	V
Gate Driver					
Gate driver supply (internal generated)	V _{CP_REG}	10	12	13	V
Voltages on low side driver pins high (LSx)	V _{OLSH}	10	12	13	V
Voltages on low side driver pins low (LSx)	V _{OLSL}	-0.3	0		V
Voltages on high side driver pins high (HSx)	V _{OHS}	VM+10	VM+12	VM+13	V
Voltages on high side driver pins low (HSx)	V _{OHSL}		V _{BM}		
Pull-up ON resistance high-side gate driver	R _{ONHS}	2.0	4.0	9.2	Ω
Pull-up ON resistance low-side gate driver	R _{ONLS}	2.4	4.0	7.0	Ω
Pull-down ON resistance high-side gate driver (excluding 2R2 BM resistor)	R _{OFFHS}	2.0	5.0	9.2	Ω
Pull-down ON resistance low-side gate driver	R _{OFFLS}	1.5	4.0	5.7	Ω
Turn ON gate driver peak current	I _{ONP}		-1	-1.4	A
Turn OFF gate driver peak current	I _{OFFP}		1	1.6	A
Rise time (C=1nF, output 20% to 80%)	t _r	6	7	15	ns
Fall time (C=1nF, output 20% to 80%)	t _f	4	7	15	ns
Programmable dead time: DEAD_TIME [2:0]: [011] = 1.10μs default value. [000] [001] [010] [011] [100] [101] [110] [111]	t _{dead}	-25%	0.00 0.51 0.80 1.10 1.67 2.30 3.40 6.90	+25%	μs
Gate Driver, continued					
Programmable drain-source voltage used for short to GND detection: VDSMON [2:0]: [111] = 2V default value.	V _{VDS_MON}				V



Operational Ratings					
[000]			dis.		
[001]		0.40	0.50	0.60	
[010]		0.60	0.75	0.90	
[011]		0.85	1.00	1.15	
[100]		1.05	1.25	1.45	
[101]		1.25	1.50	1.75	
[110]		1.50	1.75	2.00	
[111]		1.70	2.00	2.30	
Programmable drain-source voltage monitor blanking time: VDS_BLANK_TIME [1:0]: [10] = 3,4µs default value.					
[00]	T _{VDS,BL}	0.60	0.80	1.00	µs
[01]		1.28	1.70	2.13	
[10]		2.55	3.40	4.25	
[11]		5.10	6.80	8.50	
3.3V Switch Regulator					
Switch regulator output voltage	U _{3.3VOUT}	3.14	3.3	3.47	V
3.3V switch regulator output current	I _{3.3VOUT}			500	mA
3.3V switch regulator frequency	f	1.8	2.25	2.8	MHz
Temperature					
Ambient temperature (limited by CPU Flash memory upper die junction temperature limit of 95°C)	T _J	-40		85	°C
Storage temperature	T _{STG}	-40		95	°C
ESD-Protection (Human body model, HBM)	V _{ESD}			2 (tbd)	kV

Table 7: Operational Ratings



6 Mechanical Dimensions

6.1 TMCC160 Package Footprint

The TMCC160 uses a special LGA package (similar to QFNs) with 51 leads.

LGA51 Package Drawing

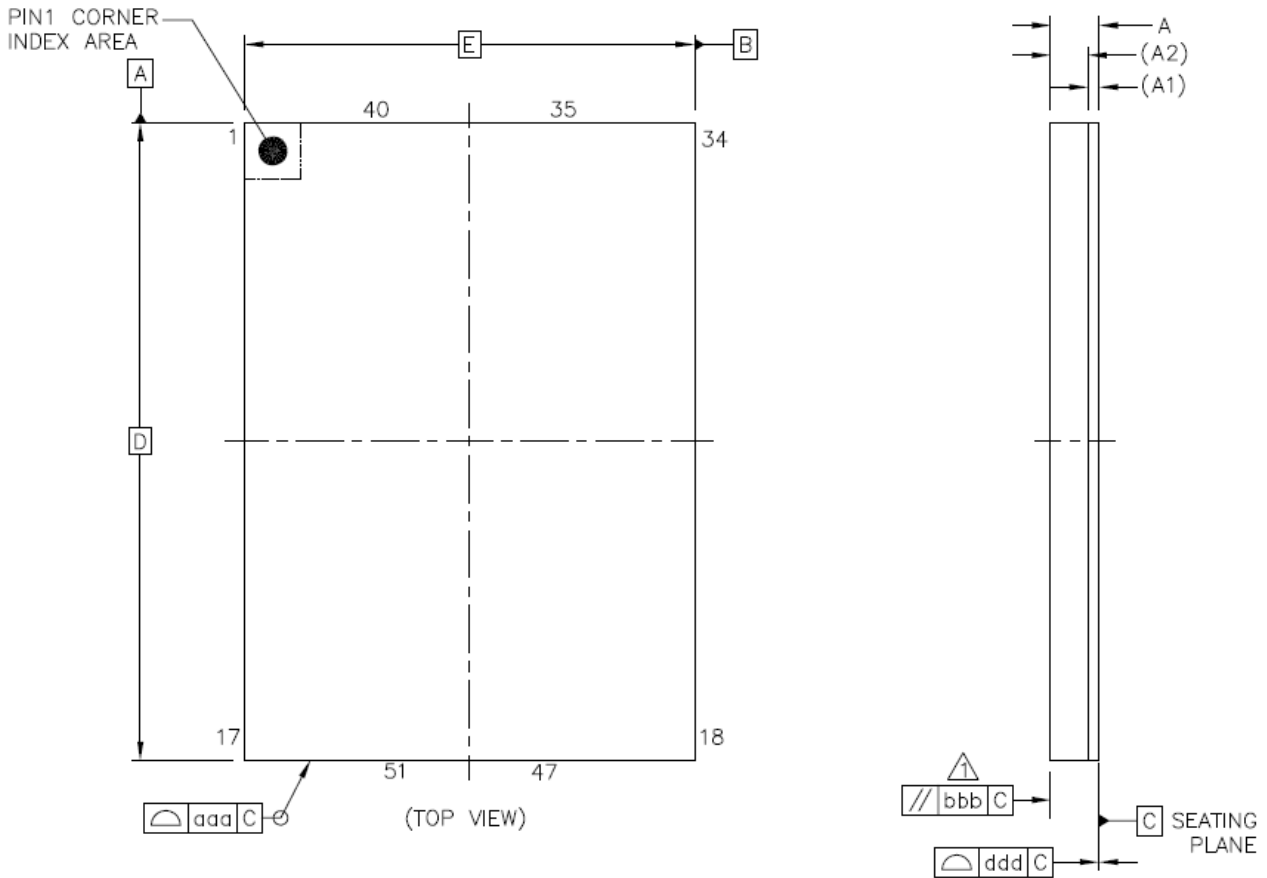

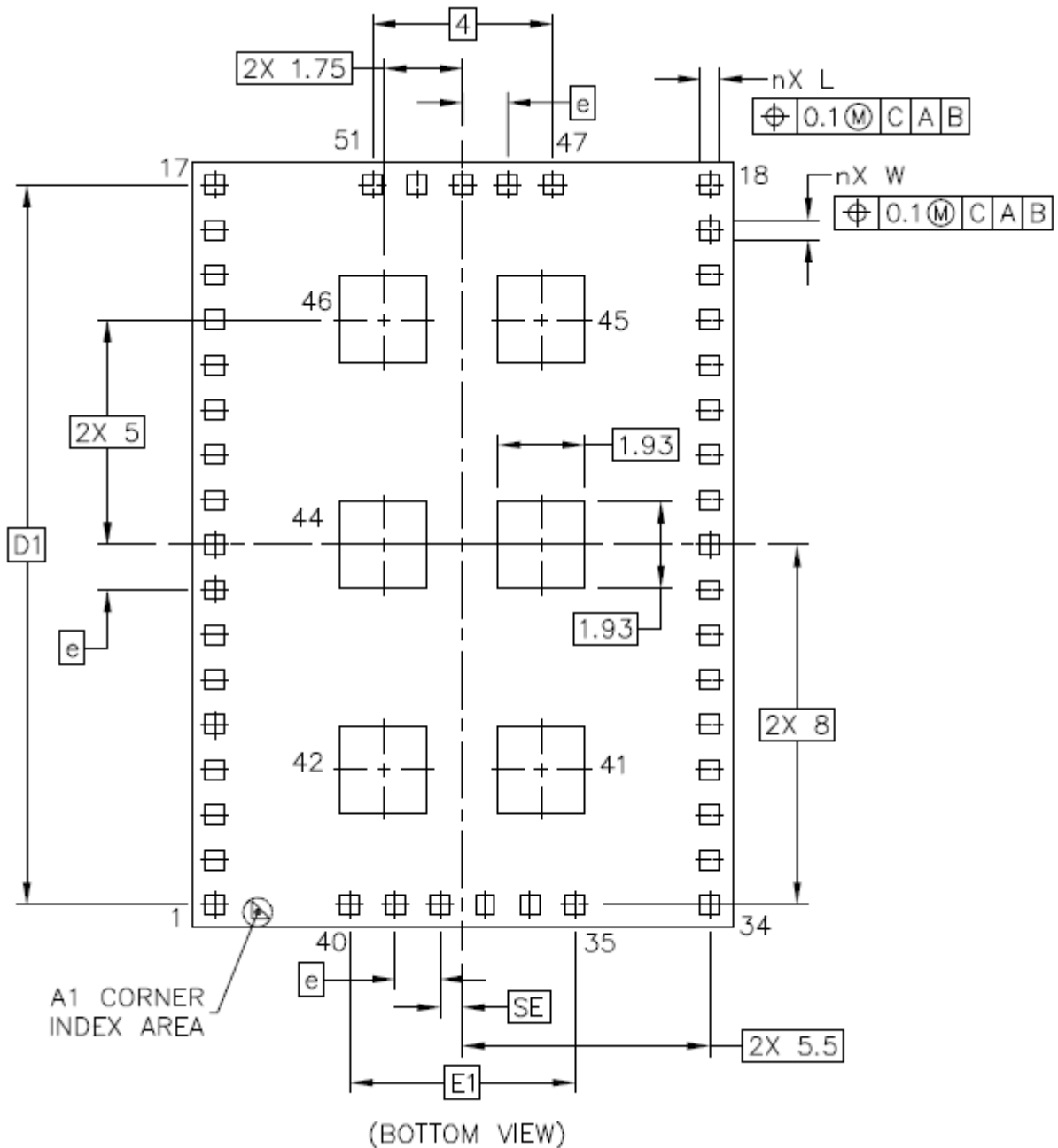

Figure 23: TMCC160 LGA51 Package Drawing

Table 8 Package Dimensions

TMCC160 Package Dimension				
Attribute	SYMBOL	DIMENSION [mm]		
		MIN	TYP	MAX
Total Thickness	A	-	-	1.4
Body Size	D	17		
	E	12		
Lead Width	W	0.38	0.43	0.48
Lead Length	L	0.38	0.43	0.48



Lead Pitch	e	1
Lead Count	n	51
Edge Ball Center to Center	D1	16
	E1	5
Body Center to Contact Ball	SD	-
	SE	0.5
Package Edge Tolerance	aaa	0.1
Mold Flatness	bbb	0.2
Coplanarity	ddd	0.08

Package Code

Package Code			
Type	Package	Temperature range	Code & marking
TMCC160-LC	LGA-51 (RoHS)	-40°C ... +85°C	TMCC160-LC

Table 9: Package Code

Marking Code

Marking Code			
Type	Picture	Date code	Lot number
TMCC160-LC		WW: week YY: year	LLLL: Lot number

Table 10 Marking Code

6.1.1 Soldering Profile

TMCC160 system in a package is compatible with the JESD22 reflow soldering profile.



7 SUPPLEMENTAL DIRECTIVES



Read the entire documentation before you make use of this product:

Keep this manual and all other applicable and related documents complete, legible and accessible to the specified user at all times.

Failure to observe the Supplemental Directives could result in damage to product and things; to property or persons; or economic loss.

TRINAMIC is not liable for damages incurred as a result of improper use or disregard of the instructions provided in this document.

i

In case you encounter difficulties or need additional advice, please contact our support team via: www.trinamic.com. Thank you.

7.1 ESD Sensitive Device



This product is an ESD-sensitive CMOS device. It is sensitive to electrostatic discharge.

- Provide effective grounding to protect personnel and machines.
- Ensure work is performed in a non-static environment.
- Use personal ESD control footwear and ESD wrist straps, if necessary.

Failure to do so can result in defects, damages and decreased reliability.

7.2 Disclaimer

TRINAMIC Motion Control GmbH & Co. KG does not authorize or warrant any of its products for use in life support systems, without the specific written consent of TRINAMIC Motion Control GmbH & Co. KG. Life support systems are equipment intended to support or sustain life, and whose failure to perform, when properly used in accordance with instructions provided, can be reasonably expected to result in personal injury or death.

Information given in this data sheet is believed to be accurate and reliable. However no responsibility is assumed for the consequences of its use nor for any infringement of patents or other rights of third parties which may result from its use.

Specifications are subject to change without notice.

All trademarks used are property of their respective owners.



8 Revision History

8.1 Document Revision

Version	Date	Author JM	Description
0.90	2015-APRIL-09	JM	Initial version.
0.91	2015-APRIL-10	JM	Add periphery sample schematics.
0.92	2015-MAY-26	JM	
0.93	2015-JULY-15	JM	Add brake chopper, revise gate driver parameters
0.94	2015-AUG-15	JM	Add chapter soldering profile Add chapter software revision Add chapter ESD Sensitive Device Add chapter Disclaimer Add chapter Package Code
0.95	2015-SEPT-03	JM	Add chapter Clamp Diode
0.96	2015-OCT-30	JP	Formatting and Short Specification
1.00	2015-NOV-11	BD, JM	Final Edits

Table 11 Document revision

8.2 Hardware Revision

Version	Date	Description
TMCC160-ES V1.0	2015-APRIL	Initial Prototype Lot

Table 12 Hardware revision

8.3 Software Revision

Version	Date	Description
V2.07	2015-JUN-11	Initial TMCC160 Firmware
V2.08	2015-SEPT-21	Changes Brake Chopper Algorithm

Table 13 Hardware revision



X-ON Electronics

Largest Supplier of Electrical and Electronic Components

Click to view similar products for [Motor/Motion/Ignition Controllers & Drivers](#) category:

Click to view products by [Analog Devices](#) manufacturer:

Other Similar products are found below :

[FSB50550TB2](#) [FSBF15CH60BTH](#) [MSVCPM2-63-12](#) [MSVGW45-14-2](#) [MSVGW54-14-3](#) [MSVGW54-14-5](#) [NTE7043](#) [LA6565VR-TLM-E](#)
[LB11650-E](#) [LB1837M-TLM-E](#) [LB1845DAZ-XE](#) [LC898300XA-MH](#) [SS30-TE-L-E](#) [26700](#) [LV8281VR-TLM-H](#) [BA5839FP-E2](#) [IRAM236-1067A](#) [LA6584JA-AH](#) [LB11847L-E](#) [NCV70501DW002R2G](#) [AH293-PL-B](#) [STK672-630CN-E](#) [TND315S-TL-2H](#) [FNA23060](#) [FSB50250AB](#)
[FNA41060](#) [MSVB54](#) [MSVBTC50E](#) [MSVCPM3-54-12](#) [MSVCPM3-63-12](#) [MSVCPM4-63-12](#) [MSVTA120](#) [FSB50550AB](#)
[NCV70501DW002G](#) [LC898301XA-MH](#) [LV8413GP-TE-L-E](#) [MSVGW45-14-3](#) [MSVGW45-14-4](#) [MSVGW45-14-5](#) [MSVGW54-14-4](#)
[STK984-091A-E](#) [SLA7026M](#) [MP6519GQ-Z](#) [LB11651-E](#) [IRSM515-025DA4](#) [LV8127T-TLM-H](#) [NCP81382MNTXG](#) [TDA21801](#)
[LB11851FA-BH](#) [NCV70627DQ001R2G](#)