

Hardware Version V3.0

HARDWARE MANUAL

+

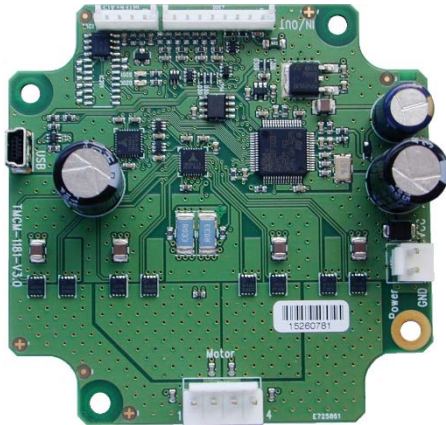

+

+

TMCM-1181

1-axis Stepper
Controller / Driver
up to 6.5 RMS / 24V DC
USB, RS485

+

UNIQUE FEATURES:



coolStep™

stallGuard²™

TRINAMIC Motion Control GmbH & Co. KG
Hamburg, Germany

www.trinamic.com



TRINAMIC
MOTION CONTROL

Table of Contents

1	Features.....	3
2	Order Codes	5
3	Mechanical and Electrical Interfacing.....	6
3.1	TMC1181 Dimensions and Mounting Holes.....	6
3.2	Board mounting considerations	6
3.3	Connectors of TMC1181.....	7
3.3.1	Power Connector.....	8
3.3.2	Motor Connector.....	8
3.3.3	Interface Connector.....	9
3.3.4	In/Out Connector.....	10
3.3.5	USB Connector	11
4	On-board LEDs.....	12
5	Operational Ratings	13
6	Functional Description.....	14
7	TMC1181 Operational Description	15
7.1	Calculation: Velocity and Acceleration vs. Microstep and Fullstep Frequency.....	15
8	Life Support Policy.....	17
9	Revision History.....	18
9.1	Document Revision.....	18
9.2	Hardware Revision	18
10	References	18

1 Features

The TMC1181 is a single axis controller/driver module for 2-phase bipolar stepper motors. It is highly integrated and can be used in many decentralized applications. The module can be mounted on the back of NEMA34 (86mm flange size) stepper motors and has been designed for coil currents up to 6.5A RMS (programmable) and 24V DC supply voltage. With its high energy efficiency from TRINAMIC's coolStep™ technology cost for power consumption is kept down. The TMCL™ firmware supports both, standalone operation and direct mode.

MAIN CHARACTERISTICS

Motion controller

- Motion profile calculation in real-time
- On the fly alteration of motor parameters (e.g. position, velocity, acceleration)
- High performance microcontroller for overall system control and serial communication protocol handling

Bipolar stepper motor driver

- Up to 256 microsteps per full step
- High-efficient operation, low power dissipation
- Dynamic current control
- Integrated protection
- stallGuard2 feature for stall detection
- coolStep feature for reduced power consumption and heat dissipation

Encoder

- sensOstep magnetic encoder (max. 1024 increments per rotation) e.g. for step-loss detection under all operating conditions and positioning supervision

Interfaces

- inputs for stop switches (left and right) and home switch
- 2 analog inputs
- 2 general purpose outputs (open collector with freewheeling diodes)
- USB, RS485 communication interfaces

Software

- TMCL: standalone operation or remote controlled operation, program memory (non volatile) for up to 2048 TMCL commands, and PC-based application development software TMCL-IDE available for free.

Electrical and mechanical data

- Supply voltage: +24V DC nominal
- Motor current: up to 6.5A RMS (programmable)

Please see separate TMC1181 Firmware Manual for additional information regarding firmware functionality and TMCL programming.

TRINAMICS UNIQUE FEATURES – EASY TO USE WITH TMCL

stallGuard2™ stallGuard2 is a high-precision sensorless load measurement using the back EMF on the coils. It can be used for stall detection as well as other uses at loads below those which stall the motor. The stallGuard2 measurement value changes linearly over a wide range of load, velocity, and current settings. At maximum motor load, the value goes to zero or near to zero. This is the most energy-efficient point of operation for the motor.

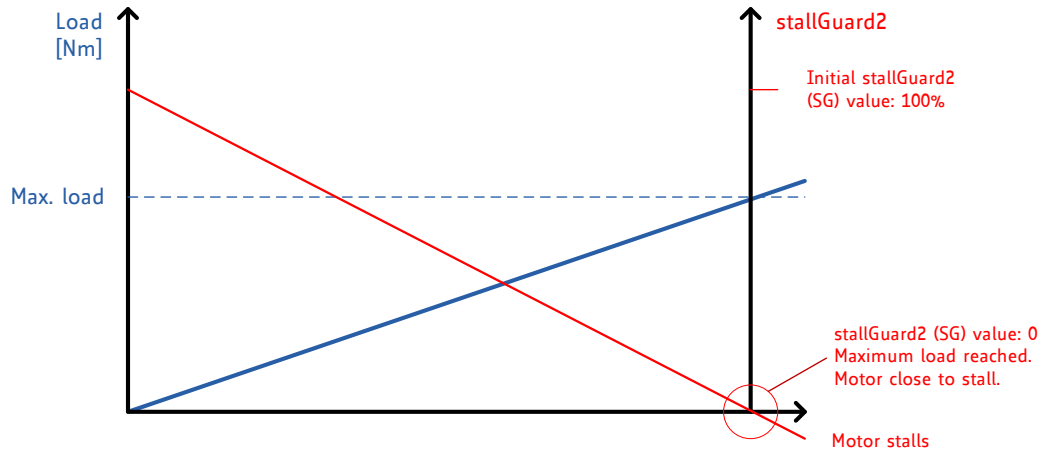

Figure 1.1 stallGuard2 load measurement SG as a function of load

coolStep™ coolStep is a load-adaptive automatic current scaling based on the load measurement via stallGuard2 adapting the required current to the load. Energy consumption can be reduced by as much as 75%. coolStep allows substantial energy savings, especially for motors which see varying loads or operate at a high duty cycle. Because a stepper motor application needs to work with a torque reserve of 30% to 50%, even a constant-load application allows significant energy savings because coolStep automatically enables torque reserve when required. Reducing power consumption keeps the system cooler, increases motor life, and allows reducing cost.

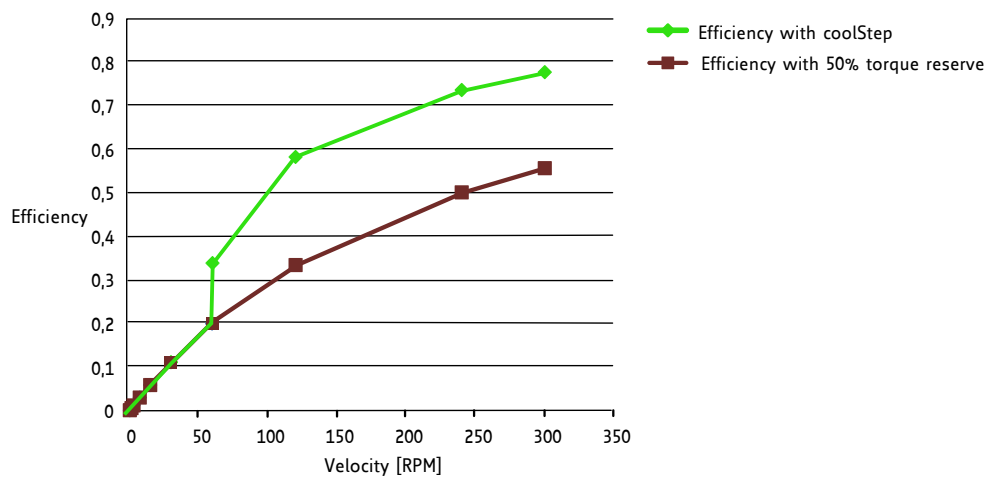

Figure 1.2 Energy efficiency example with coolStep

2 Order Codes

Order code	Description	Size (mm ³)
TMCM-1181	1-Axis bipolar stepper motor controller / driver, up-to 6.5A RMS, 24V DC, with integrated sensOstep encoder and coolStep feature	86 x 86 x 27

Table 2.1: TMCM-1181 order codes

A cable loom set is available for this module:

Order code	Description
TMCM-1181-CABLE	Cable loom for TMCM-1181 <ul style="list-style-type: none"> - 1x cable loom for interface connector - 1x cable loom for In/Out connector - 1x cable loom for motor connector - 1x cable loom for power connector - 1x USB type A connector to mini-USB type B connector cable

Table 2.2 Cable loom order code

3 Mechanical and Electrical Interfacing

3.1 TCMC-1181 Dimensions and Mounting Holes

The dimensions of the controller/driver board are approx. 86mm x 86mm x 27mm in order to fit on the back of a 86mm stepper motor. Maximum component height (height above PCB level) is around 22mm above PCB level and 3mm below PCB level. There are four mounting holes for M4 screws (4.2mm diameter) for mounting the board to a NEMA34 / 86mm stepper motor.

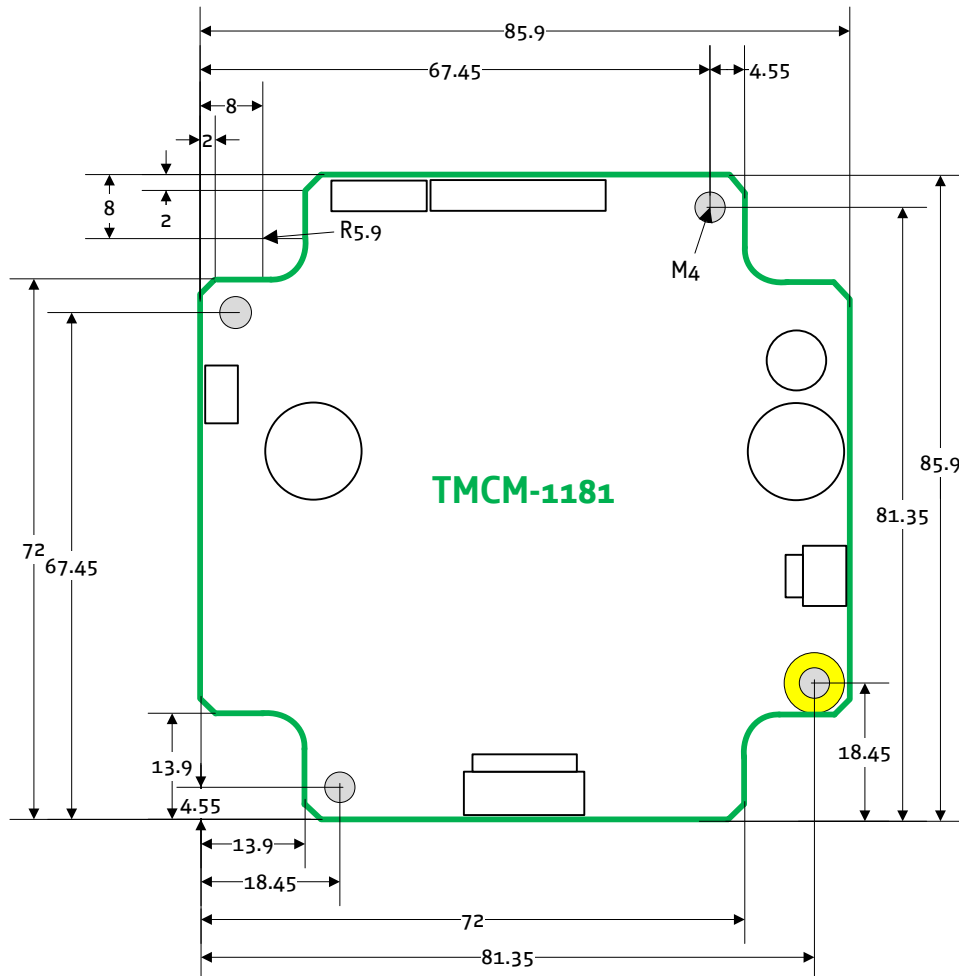

Figure 3.1: Dimensions of TCMC-1181 and position of mounting holes

3.2 Board mounting considerations

The TCMC-1181 offers one metal plated mounting hole close to the power supply connector (marked yellow in figure 3.1 above). This mounting hole is connected to board supply ground. Please keep this in mind when mounting the board to the rear side of a motor. All other mounting holes are isolated.

3.3 Connectors of TMCM-1181

The TMCM-1181 offers five connectors including the motor connector which is used for attaching the motor coils to the electronics. There is one power connector, two connectors for serial communication (one for USB and one for RS485) and one connector for I/O signals and switches.

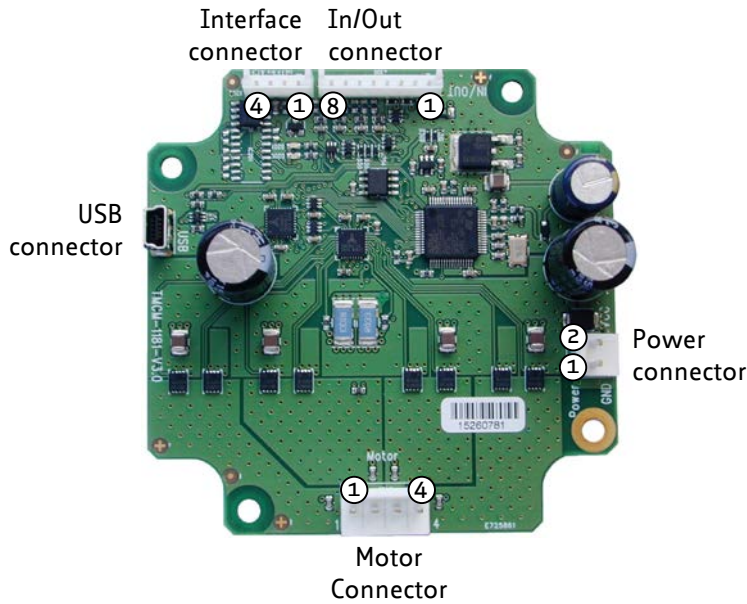

Figure 3.2 Overview connectors

Domain	Connector type	Mating connector type
Power	JST B2P-VH (JST VH series, 2pins, 3.96mm pitch)	Crimp connector housing: JST VHR-2N Crimp contacts: JST SVH-21T-P1.1 Wire: 0.83mm ² , AWG 18
Motor	JST B4P-VH (JST VH series, 4pins, 3.96mm pitch)	Crimp connector housing: JST VHR-4N Crimp contacts: JST SVH-21T-P1.1 Wire: 0.83mm ² , AWG 18
Interface	JST B4B-EH-A (JST EH series, 4 pins, 2.5mm pitch)	Crimp connector housing: JST EHR-4 Crimp contacts: JST SEH-001T-P0.6 Wire: 0.33mm ² , AWG 22
In/Out	JST B8B-EH-A (JST EH series, 8 pins, 2.5mm pitch)	Crimp connector housing: JST EHR-8 Crimp contacts: JST SEH-001T-P0.6 Wire: 0.33mm ² , AWG 22
USB	Mini-USB type B vertical female	Mini-USB type B, male

3.3.1 Power Connector

A 2pin JST VH series 3.96mm pitch connector is used for power supply.

	Pin	Label	Direction	Description
	1	GND	Power (GND)	System and signal ground
	2	VCC	Power (+24V)	Power supply input

Table 3.1 Connector for power supply

CAUTION

Always keep the power supply voltage below the upper limit of 28V!
 Otherwise the driver electronics will be seriously damaged. Especially, when the selected operating voltage is near the upper limit a regulated power supply is highly recommended.

3.3.1.1 Power Supply

When using supply voltages near the upper limit, a regulated power supply is mandatory. The board includes around 2000 μ F / 35V of filtering capacitors. Nevertheless, especially at higher motor current settings it might be necessary to add additional filtering capacitors externally. Power supply ripple due to chopper operation of the driver should be kept at a maximum of a few 100mV.

It is important that the upper supply voltage limit is never exceeded during operation as this might seriously damage the driver stage. In this context special care has to be taken with regard to motor energy being fed back into supply voltage line when the motor works as generator. This might happen during de-acceleration or brake conditions especially when the motor is moving a larger mass (high inertia). Additional capacitors which are able to absorb energy might help here. Beyond that suppressor diodes or even brake resistors might be a solution.

Guidelines for power supply:

- keep power supply cables as short as possible
- use large diameters for power supply cables
- add additional filter capacitors near the motor driver unit especially if the distance to the power supply is large (i.e. more than 2-3m)

Note: there is no protection against reverse polarity integrated on the board.

3.3.2 Motor Connector

A 4pin JST VH series 3.96mm pitch connector is used for motor connection.

	Pin	Label	Direction	Description
	1	A1	Output	Pin 1 of motor coil A
	2	A2	Output	Pin 2 of motor coil A
	3	B1	Output	Pin 1 of motor coil B
	4	B2	Output	Pin 2 of motor coil B

Table 3.2: Motor connector

3.3.3 Interface Connector

A 4pin JST EH series 2.5mm pitch connector is used as Interface Connector.

	Pin	Label	Direction	Description
	1	GND	Power (GND)	Module ground (system and signal ground)
	2	IN4	Input	Analog input 4, 0... 10V (analog to digital converter range)
	3	RS485+	Bi-directional	Differential RS485 bus signal (non-inverting)
	4	RS485-	Bi-directional	Differential RS485 bus signal (inverting)

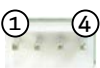
Table 3.3: Interface connector

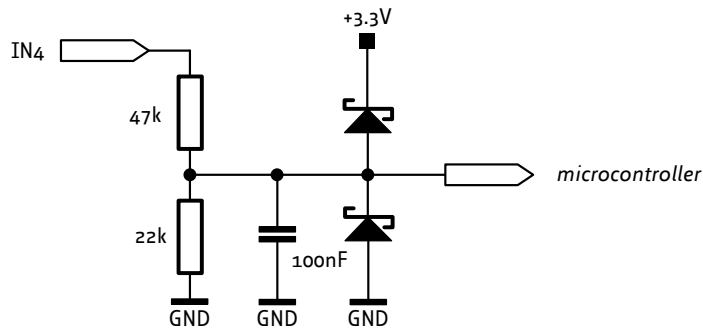

Figure 3.3 Internal circuit of analog input IN4

3.3.4 In/Out Connector

An 8pin JST EH series 2.5mm pitch connector is used as In/Out Connector.

Pin	Label	Direction	Description
1	GND	Power (GND)	Module ground (system and signal ground)
2	VCC_OUT	Power supply output	Power supply output connected to VCC (pin 2) of power supply connector via 0.2A polyfuse. This way up-to 200mA (polyfuse protected) may be used from this pin for supply of external circuits (e.g. limit / home switches, load connected to OUT0/1 etc.)
3	OUT0	Output	General purpose output, open collector
4	OUT1	Output	General purpose output, open collector
5	IN0	Input	Analog input 0, 0... 10V (analog to digital converter range)
6	STOP_L/ STEP/ IN1	Input	Digital input, +24V compatible, programmable internal pull-up.* Functionality can be selected in software: a) Left stop switch input (connected to REF1 input of TMC429 motion controller) b) Step signal (connected to step input of TMC262 stepper driver) c) General purpose input 1 (connected to processor)
7	STOP_R/ DIR/ IN2	Input	Digital input +24V compatible, programmable internal pull-up.* Functionality can be selected in software: a) Right stop switch input (connected to REF3 input of TMC429 motion controller) b) Direction signal (connected to direction input of TMC262 stepper driver) c) General purpose input 2 (connected to processor)
8	HOME/ ENABLE/ IN3	Input	Digital input +24V compatible, programmable internal pull-up.* Functionality can be chosen in software: a) Home switch input (connected to processor) b) Enable signal (connected to processor) c) General purpose input 3 (connected to processor)

Table 3.4 In/Out connector

* It is possible to enable / disables pull-ups (1k to +5V) in software for all three digital inputs. Pull-ups are always enabled / disabled for all three together / at the same time.

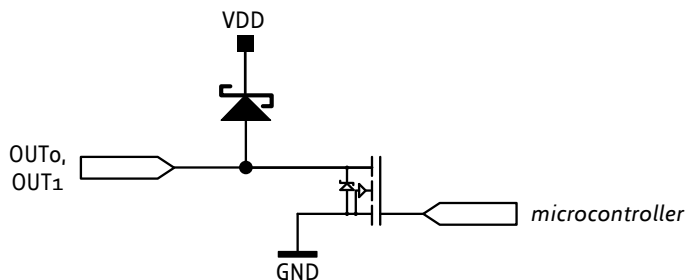

Figure 3.4 Internal circuit of OUT0 and OUT1

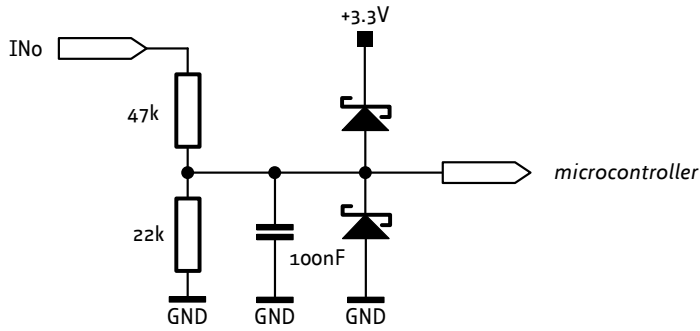

Figure 3.5 Internal circuit of analog input IN0

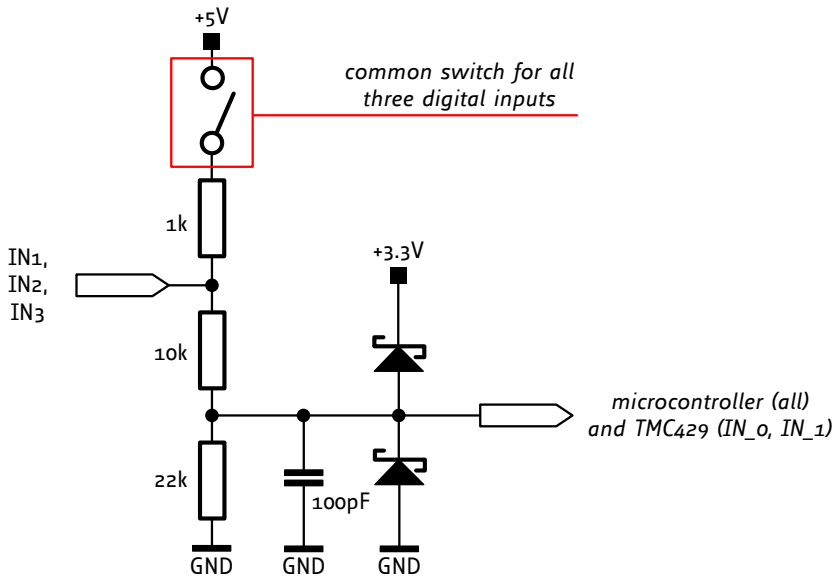

Figure 3.6 Internal circuit of digital inputs IN1, IN2 and IN3

3.3.5 USB Connector

Pin	Label	Description
5	VBUS	+5V power
2	D-	Data -
3	D+	Data +
4	ID	not connected
5	GND	ground

Table 3.5 Mini USB connector

4 On-board LEDs

The board offers two LEDs in order to indicate board status. The function of both LEDs is dependent on the firmware version. With standard TMCL firmware the green LED should be slowly flashing during operation and the red LED should be off.

When there is no valid firmware programmed into the board or during firmware update the red and green LEDs are permanently on.

BEHAVIOR OF LEDs WITH STANDARD TMCL FIRMWARE

Status	Label	Description
Heartbeat	Status LED (green)	This green LED flashes slowly during operation.
Error	Error LED (red)	This red LED lights up if an error occurs.

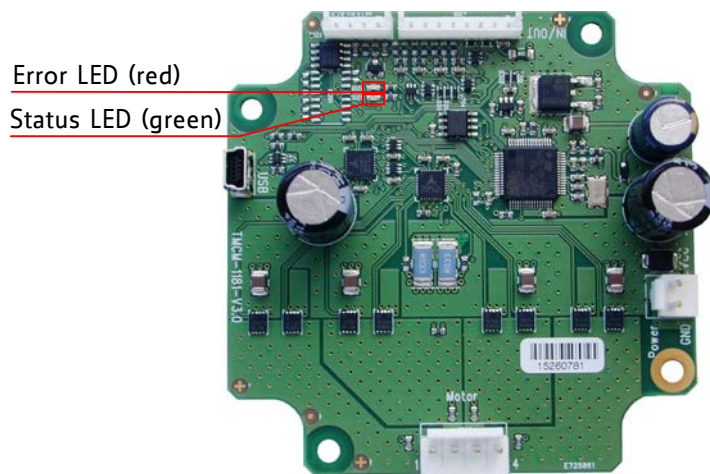

Figure 4.1 on-board LEDs

5 Operational Ratings

The operational ratings shown below should be used as design values. In no case should the maximum values be exceeded during operation.

Symbol	Parameter	Min	Typ	Max	Unit
VCC	Power supply voltage for operation	11	24	28	V DC
V _{USB}	Power supply via USB connector		5		V
I _{USB}	Current withdrawn from USB supply when USB bus powered (no other supply connected)		40		mA
I _{COIL_peak}	Motor coil current for sine wave peak (chopper regulated, adjustable via software)	0		9.2	A
I _{COIL_RMS}	Continuous motor current (RMS)	0		6.5	A
I _{SUPPLY}	Power supply current		<< I _{COIL}	1.4 * I _{COIL}	A
T _{ENV}	Environment temperature at rated current (no forced cooling required)	-30 ^{*)}		+60	°C

Table 5.1 General operational ratings of the module

^{*)} limited by test equipment. Includes power-up / cold start at this temperature. It can be expected that the module will work down to -40°C.

Symbol	Parameter	Min	Typ	Max	Unit
V _{STOP_L/R_HOME}	Input voltage for stop / home switch inputs STOP_L / STOP_R and HOME (also valid when configured for alternate function)	0		28	V
V _{STOP_L/R_HOME_L}	Low level voltage for stop / home switch inputs STOP_L / STOP_R and HOME (also valid when configured for alternate function)	0		1.1	V
V _{STOP_L/R_HOME_H}	High level voltage for stop / home switch inputs STOP_L / STOP_R and HOME (also valid when configured for alternate function)	2.9		28	V
V _{OUT_0/1}	Voltage at open collector output OUT_0 / OUT_1	0		VCC	V
I _{OUT_0/1}	Output sink current for OUT_0 / OUT_1			100	mA
V _{IN_0}	Full scale input voltage range for analog input IN_0	0		10	V

Table 5.2 Operational ratings of general purpose I/Os

Symbol	Parameter	Min	Typ	Max	Unit
N _{RS485}	Number of nodes connected to single RS485 network			256	

Table 5.3 Operational ratings of the RS485 interface

6 Functional Description

The TMCM-1181 is a highly integrated controller/driver module which can be controlled via several serial interfaces. Communication traffic is kept low since all time critical operations (e.g. ramp calculations) are performed on board. The nominal supply voltage of the unit is 24V DC. The module is designed for both, standalone operation and direct mode. Full remote control of device with feedback is possible. The firmware of the module can be updated via any of the serial interfaces.

In Figure 6.1 the main parts of the TMCM-1181 are shown.

- the microprocessor, which runs the TMCL operating system (connected to TMCL memory),
- the motion controller, which calculates ramps and speed profiles internally by hardware,
- the power driver with its energy efficient coolStep feature,
- the MOSFET driver stage, and
- the sensOstep encoder with resolutions of 10bit (1024 steps) per revolution.

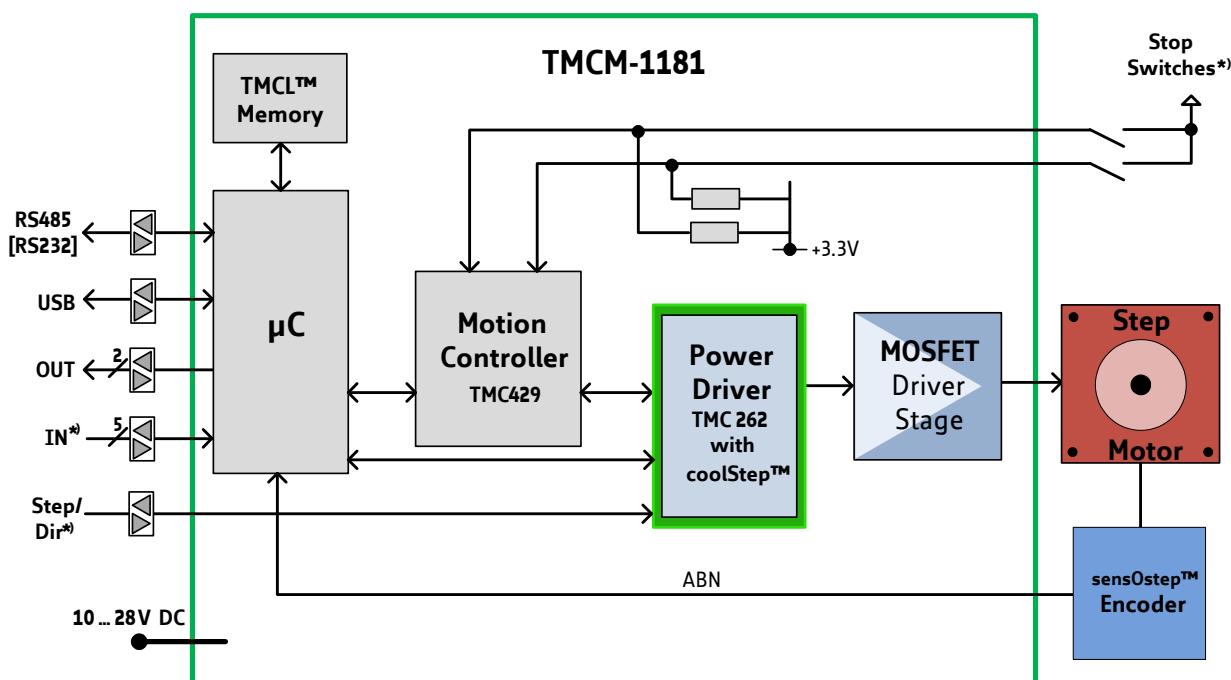

- *) The module offers two analog and three digital inputs.
 Functionality of the three digital inputs can be selected in software:
- a) STOP_L / STOP_R / HOME
 - b) STEP/DIR interface
 - c) 3 general purpose inputs IN1 / IN2 / IN3

Figure 6.1 Main parts of the TMCM-1181

The PC based software development environment TMCL-IDE for the Trinamic Motion Control Language (TMCM) can be downloaded free of charge from the TRINAMIC website (www.trinamic.com). Using predefined TMCL high level commands like *move to position* a rapid and fast development of motion control applications is guaranteed. Please refer to the TMCM-1181 Firmware Manual for more information about TMCL commands.

7 TCM-1181 Operational Description

7.1 Calculation: Velocity and Acceleration vs. Microstep and Fullstep Frequency

The values of the parameters sent to the TMC429 do not have typical motor values like rotations per second as velocity. But these values can be calculated from the TMC429 parameters as shown in this section.

PARAMETERS OF TMC429

Signal	Description	Range
f _{CLK}	clock-frequency	16 MHz
velocity	-	0... 2047
a _{max}	maximum acceleration	0... 2047
pulse_div	divider for the velocity. The higher the value is, the less is the maximum velocity default value = 0	0... 13
ramp_div	divider for the acceleration. The higher the value is, the less is the maximum acceleration default value = 0	0... 13
Usrs	microstep-resolution (microsteps per fullstep = 2 ^{usrs})	0... 8 (a value of 7 or 8 is internally mapped to 6 by the TMC429)

Table 7.1 TMC429 velocity parameters

The **microstep-frequency** of the stepper motor is calculated with

$$\text{usf}[\text{Hz}] = \frac{f_{\text{CLK}}[\text{Hz}] \cdot \text{velocity}}{2^{\text{pulse_div}} \cdot 2048 \cdot 32} \quad \text{with usf: microstep-frequency}$$

To calculate the **fullstep-frequency** from the microstep-frequency, the microstep-frequency must be divided by the number of microsteps per fullstep.

$$\text{fsf}[\text{Hz}] = \frac{\text{usf}[\text{Hz}]}{2^{\text{usrs}}} \quad \text{with fsf: fullstep-frequency}$$

The change in the pulse rate per time unit (pulse frequency change per second – the **acceleration a**) is given by

$$a = \frac{f_{\text{CLK}}^2 \cdot a_{\text{max}}}{2^{\text{pulse_div} + \text{ramp_div} + 29}}$$

This results in acceleration in fullsteps of:

$$\text{af} = \frac{a}{2^{\text{usrs}}} \quad \text{with af: acceleration in fullsteps}$$

Example:

Signal	value
f_CLK	16 MHz
velocity	1000
a_max	1000
pulse_div	1
ramp_div	1
usrs	6

$$msf = \frac{16 \text{ MHz} \cdot 1000}{2^1 \cdot 2048 \cdot 32} = \underline{\underline{122070.31 \text{ Hz}}}$$

$$fsf[\text{Hz}] = \frac{122070.31}{2^6} = \underline{\underline{1907.34 \text{ Hz}}}$$

$$a = \frac{(16 \text{ MHz})^2 \cdot 1000}{2^{1+1+29}} = \underline{\underline{119.21 \frac{\text{MHz}}{\text{s}}}}$$

$$af = \frac{119.21 \frac{\text{MHz}}{\text{s}}}{2^6} = \underline{\underline{1.863 \frac{\text{MHz}}{\text{s}}}}$$

Calculation of the number of rotations:

A stepper motor has e.g. 72 fullsteps per rotation.

$$\text{RPS} = \frac{fsf}{\text{fullsteps per rotation}} = \frac{1907.34}{72} = 26.49$$

$$\text{RPM} = \frac{fsf \cdot 60}{\text{fullsteps per rotation}} = \frac{1907.34 \cdot 60}{72} = 1589.46$$

8 Life Support Policy

TRINAMIC Motion Control GmbH & Co. KG does not authorize or warrant any of its products for use in life support systems, without the specific written consent of TRINAMIC Motion Control GmbH & Co. KG.

Life support systems are equipment intended to support or sustain life, and whose failure to perform, when properly used in accordance with instructions provided, can be reasonably expected to result in personal injury or death.

© TRINAMIC Motion Control GmbH & Co. KG 2015

Information given in this data sheet is believed to be accurate and reliable. However neither responsibility is assumed for the consequences of its use nor for any infringement of patents or other rights of third parties, which may result from its use.

Specifications are subject to change without notice.

All trademarks used are property of their respective owners.



9 Revision History

9.1 Document Revision

Version	Date	Author	Description
0.90	2015-JUL-10	GE	Initial version

Table 9.1 Document revision

9.2 Hardware Revision

Version	Date	Description
TMC1181_V30	2013-MAY-13	First version

Table 9.2 Hardware revision

10 References

[TMC1181]	TMC1181 TMCL Firmware Manual
[TMC262]	TMC262 Datasheet
[TMC429]	TMC429 Datasheet
[TMCL-IDE]	TMCL-IDE User Manual

Please refer to www.trinamic.com.

X-ON Electronics

Largest Supplier of Electrical and Electronic Components

Click to view similar products for [Motor Drives](#) category:

Click to view products by [Analog Devices](#) manufacturer:

Other Similar products are found below :

[GMA02](#) [R7DBP02L](#) [1300920283](#) [ST10-S](#) [GMA11](#) [GMA20](#) [R88DUA03LAAC100V30W](#) [R88DUA12HA](#) [R88DUP03LAAC100V30W](#)
[STR2](#) [VFD002EL11A](#) [MFMCB0030GET](#) [MFECA0030EAM](#) [1302263150](#) [1300920078](#) [R88D-GT04H](#) [R88D-GN04H-ML2](#) [R7D-BP01H](#)
[R88D-KN04L-ECT](#) [70354063](#) [79294435](#) [27358015](#) [15275008](#) [ST5-Q-EN](#) [1SFA896103R1100](#) [1SFA896103R7000](#) [1SFA896112R1100](#)
[R88D-GP08H](#) [GNCF8-11](#) [KLC35BE](#) [ST10-Q-RN](#) [1302263161](#) [SV2D10-Q-AE](#) [VX5A1300](#) [R88A-CA1C005SF-E](#) [R88A-CR1B005NF-E](#)
[SEH 71-4B](#) [LUCC12BL](#) [LUCC12FU](#) [LU9BN11L](#) [LULC08](#) [GV2P01](#) [UDS1UR6M50CANCZ183](#) [LC1D09M7](#) [103H7126-1740](#) [103H7823-1741](#) [111.3761.20.00E](#) [111.3761.30.00E](#) [808070RAT250](#) [FMJ7201FB1](#)