

TMCM-1636 Hardware Manual

HW Version V1.1 | Document Revision V1.20 • 2020-06-08

The TMCM-1636 is a single axis servo drive for 3-phase BLDC motors and DC motors with up to ca. 1000W running at +24V or +48V. It offers a CAN & UART interface with either TMCL or CANopen protocol for communication. TMCM-1636 supports various positions feedback options: 2x incremental quadrature encoders, analog encoder, digital HALL sensor, absolute SPI- and SSI-based encoders. Customization of firmware and hardware is possible.

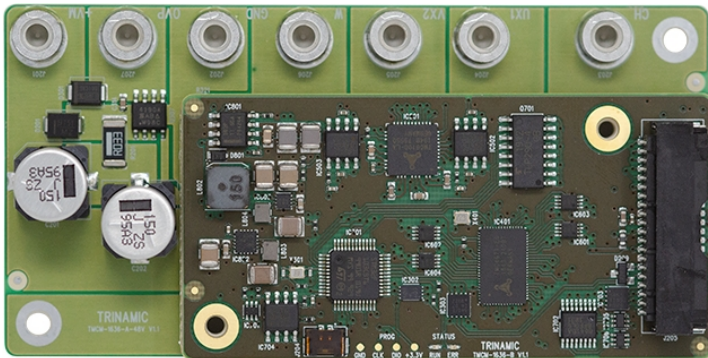

Features

- Servo Drive for BLDC and DC Motor
- +24V and +48V Supply Version
- Up to 1000W continuous
- Up to 60A RMS phase current max.
- CAN & UART interface
- 2x incremental encoder
- Digital HALL sensor
- Analog encoder option
- Absolute SPI & SSI-based encoder support
- Various GPIOs
- Motor brake control and overvoltage protection

Applications

- Robotics
- Laboratory Automation
- Manufacturing
- Factory Automation
- Servo Drives
- Motorized Tables and Chairs
- Industrial BLDC & DC Motor Drives

Simplified Block Diagram

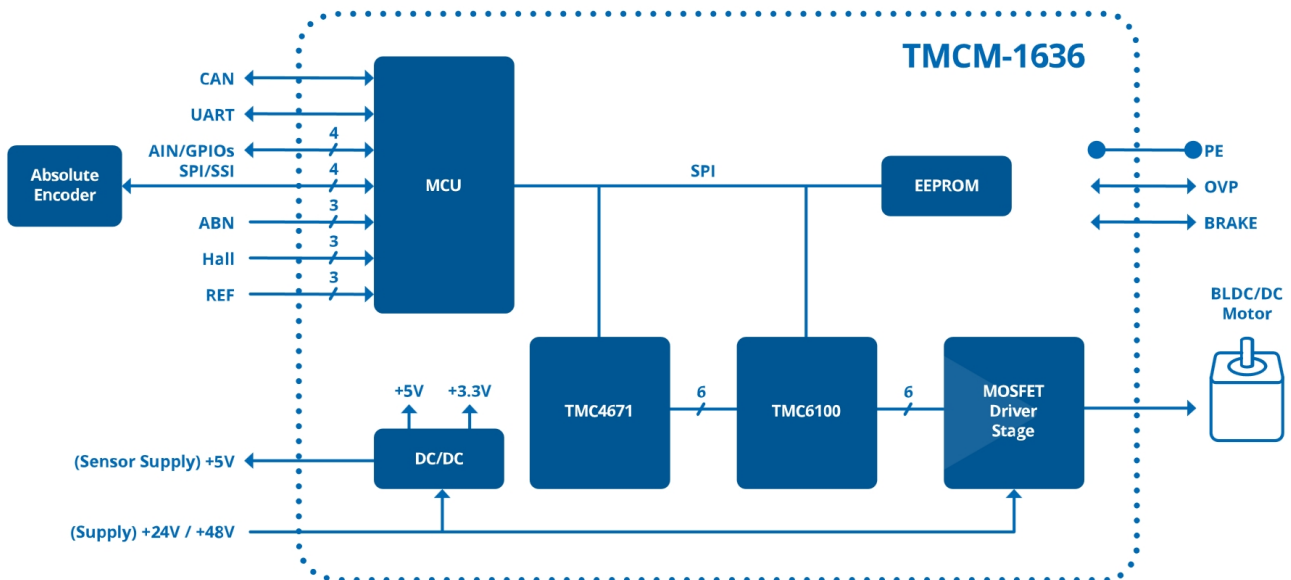

©2020 TRINAMIC Motion Control GmbH & Co. KG, Hamburg, Germany
 Terms of delivery and rights to technical change reserved.
 Download newest version at: www.trinamic.com



Read entire documentation.

Contents

1	Features	3
2	Order Codes	4
3	Connectors and Signals	5
3.1	Screw Terminals	6
3.2	I/O and Interface Connector	7
3.3	Brake Connector	9
4	Interface Circuits	10
4.1	Supply Connection and Supply Buffering	10
4.2	General Purpose Inputs	10
4.3	General Purpose Outputs	11
4.4	Analog Inputs	11
4.5	Reference Inputs	11
4.6	Brake Control Output	11
4.7	Over-Voltage Protection Output	11
4.8	Feedback Interfaces	12
4.8.1	Incremental Quadrature Encoders 1 & 2	12
4.8.2	Analog Encoder	12
4.8.3	Digital Hall Sensors	12
4.8.4	SPI-based Absolute Encoder	12
4.8.5	RS422-based Absolute Encoder	12
5	LED Status Indicators	13
6	Communication	13
6.1	CAN	13
7	Operational Ratings and Characteristics	14
7.1	Absolute Maximum Ratings	14
7.2	Operational Ratings	14
7.3	I/O Ratings	14
7.4	Other Requirements	15
8	Figures Index	16
9	Tables Index	17
10	Supplemental Directives	18
10.1	Producer Information	18
10.2	Copyright	18
10.3	Trademark Designations and Symbols	18
10.4	Target User	18
10.5	Disclaimer: Life Support Systems	18
10.6	Disclaimer: Intended Use	18
10.7	Collateral Documents & Tools	19
11	Revision History	20
11.1	Hardware Revision	20
11.2	Document Revision	20



1 Features

The TMCM-1636 is a single axis servo drive platform for 3-phase BLDC motors and DC motors with up to ca. 1000W running at +24V or +48V

It offers a CAN interface with either TMCL or CANopen protocol for communication.

TMCM-1636 supports various positions feedback options: 2x incremental quadrature encoders, analog encoder, digital hall sensors, absolute SPI- and SSI-based encoders.

Customization of firmware and hardware is possible.

Controller & Driver

- TMCM-1636-24V-TMCL/CANOPEN
 - Motor current: up to 30A RMS continuous, 60A RMS short time peak¹
 - Supply voltage: +24VDC nominal
- TMCM-1636-48V-TMCL/CANOPEN
 - Motor current: up to 20A RMS continuous, 60A RMS short time peak¹
 - Supply voltage: +48VDC nominal
- Field Oriented Control in hardware with up to 100kHz PWM and current control loop
- Support for DC and BLDC motors
- Temperature rating: -30...+60°

Position Feedback

- 2x Incremental encoder (ABN)
- Analog encoder option
- Digital HALL sensors
- SPI-based absolute encoders, depending on firmware option
- RS422-based absolute encoders (SSI, BiSS), depending on firmware option
- +5VDC supply for external sensors

IO & Interfaces

- CAN interface with on-board CAN transceiver (for TMCL or CANopen protocol)
- UART interface with +3.3V supply (supports only TMCL)
- 4x optically isolated general purpose digital inputs
- 2x general purpose outputs
- 2x analog inputs
- 3x Reference Inputs (Left, Right, Home)
- Motor brake control output
- Overvoltage protection output

¹This is the maximum current rating. This is not for continuous operation but depends on motor type, duty cycle, ambient temperature, and active/passive cooling measures.



Mechanical data

- Max. dimension: 100mm x 50mm x 18mm (L/W/H)
- Weight: ca. 70g (without mating connectors and cables)
- 2x M3 mounting holes
- Optional cooling via aluminum PCB bottom side

Software Options

- TMCL™ remote (direct mode) and standalone operation (memory for up to 1024 TMCL™ commands), fully supported by TMCL-IDE (PC based integrated development environment). Further information given in the TMCM-1636 TMCL firmware manual.
- CANopen firmware with CANopen standard protocol stack for the CAN interface. Further information given in the TMCM-1636 CANopen firmware manual.
- Custom firmware options, for example supporting specific absolute encoder types with SPI or RS422-based interface.

2 Order Codes

Order Code	Description	Size (LxWxH)
TMCM-1636-24V-TMCL	Servo Drive, 24V Supply, with TMCL firmware	100mm x 50mm x 18mm
TMCM-1636-24V-CANOPEN	Servo Drive, 24V Supply, with CANopen firmware	100mm x 50mm x 18mm
TMCM-1636-48V-TMCL	Servo Drive, 48V Supply, with TMCL firmware	100mm x 50mm x 18mm
TMCM-1636-48V-CANOPEN	Servo Drive, 48V Supply, with CANopen firmware	100mm x 50mm x 18mm
TMCM-1636-CABLE	TMCM-1636 cable loom - 1x 2-pin Molex MicroLock Plus cable for electromagnetic brake connector - 1x 40-pin Molex MicroLock Plus cable for I/O connector - 7x 1.5sqmm leads with M4 eyelets in different color, high temp / SIF	length ca. 150mm

Table 1: TMCM-1636 Order Codes



3 Connectors and Signals

The TMCM-1636 has 9 connectors:

- 7 M4 screw terminals for supply and high voltage IO (red mark)
- 1 IO and interface connector with 40 pins (blue mark)
- 1 Brake control output connector with 2 pins (orange mark)

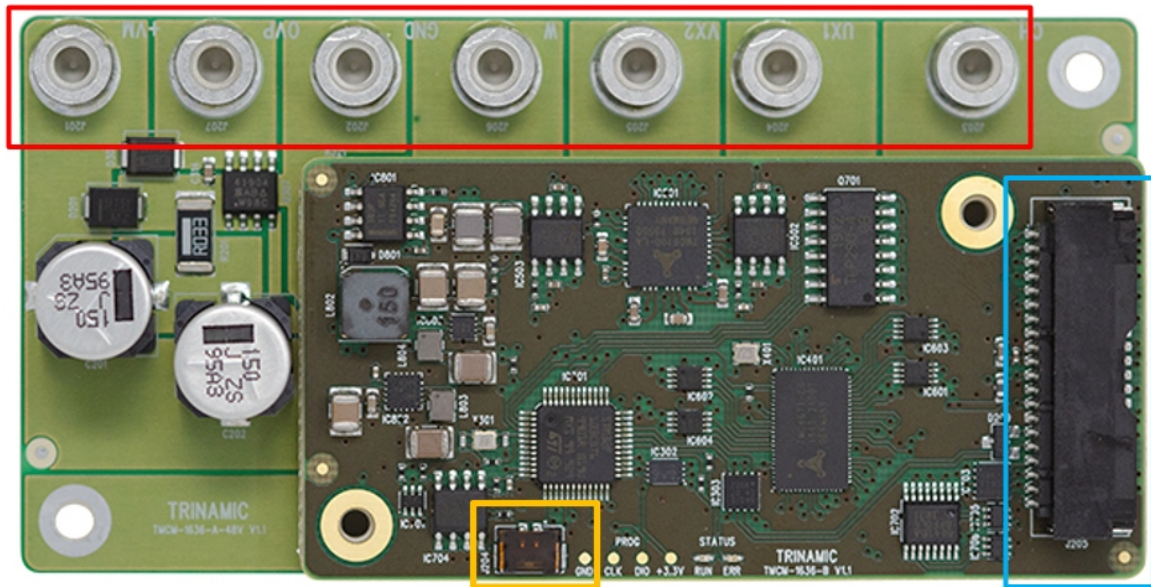

Figure 1: TMCM-1636 connectors / top view

NOTICE

Start with power supply OFF and do not connect or disconnect motor during operation! Motor cable and motor inductance might lead to voltage spikes when the motor is (dis)connected while energized. These voltage spikes might exceed voltage limits of the driver MOSFETs and might permanently damage them. Therefore, always switch off / disconnect power supply or at least disable driver stage before connecting / disconnecting motor.

NOTICE

Take care of polarity, wrong polarity can destroy the board!



3.1 Screw Terminals

Mating cables are any cables with fitting M4 cable lugs.

- NOTICE

Take care for using cables that fit to the required continuous current rating for your application!
- NOTICE

Supply cable should be as short as possible to reduce cable resistance and limit voltage drop at high load on the supply.
- NOTICE

Depending on your application make sure to add sufficient capacitors to the driver input to stabilize driver supply. Low ESR electrolyte caps are recommended, especially for higher current applications. See Section 4.1 for more information on this.

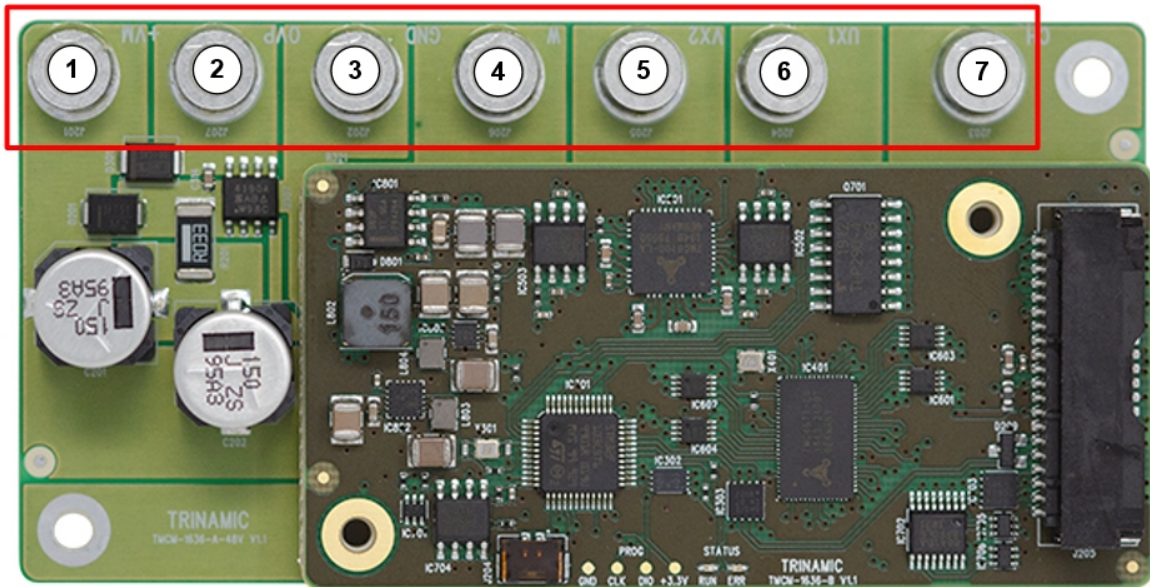

Figure 2: TMCM-1636 screw connectors

Terminal	Signal	Description
1	+VM	Motor supply voltage, voltage range depends on driver stage
2	OVP	Over-voltage protection output
3	GND	Signal and supply ground
4	W	BLDC phase W
5	V_X2	BLDC phase V, X2 for DC motor
6	U_X1	BLDC phase U, X1 for DC motor
7	CH/PE	Protective Earth/chassis ground

Table 2: TMCM-1636 screw terminals



3.2 I/O and Interface Connector

The connector is of type [Molex Micro-Lock Plus 5054484071](#) (1.25mm pitch, dual row, right-angle, 40 pins). The mating connector is [Molex 5054324001](#) (1.25mm pitch, dual row, 40 pins, positive lock, crimp housing). Use it with the following Micro-Lock Plus female crimp terminals: [Molex 5054311100](#) (1.25mm pitch, Au plating, 26-30 AWG).

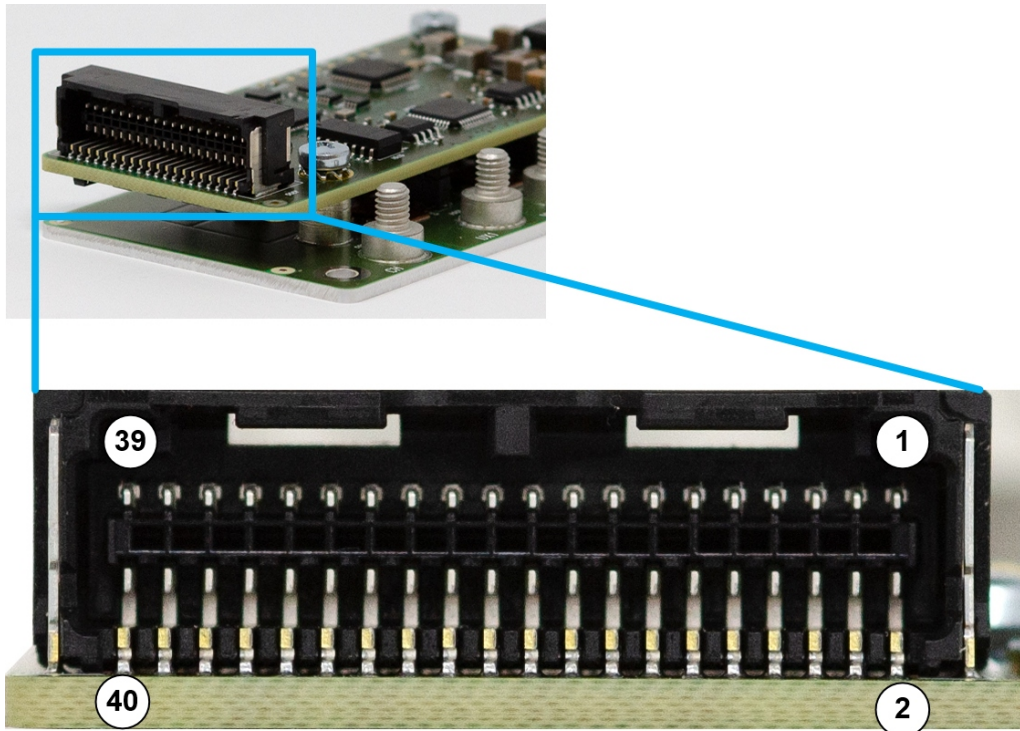

Figure 3: TMCM-1636 I/O connector

Pin	Signal	Description	Pin	Signal	Description
1	COM	COM terminal of opto-couplers for GPIx	2	AI0	Analog input 0, 0...5V range
3	GPI0	General purpose input 0, optically isolated	4	AI1	Analog input 1, 0...5V range
5	GPI1	General purpose input 1, optically isolated	6	GPO0	General purpose output 0, (open drain)
7	GPI2	General purpose input 2, optically isolated	8	GPO1	General purpose output 1, (open drain)
9	GPI3	General purpose input 3, optically isolated	10	+5V_OUT	+5V output rail for external sensor supply or signal conditioning
11	HALL_UX	Digital Hall sensor input, +5.0V level	12	ENC2_A	Digital quadrature/incremental encoder 2, A channel, +5.0V level



13	HALL_V	Digital Hall sensor input, +5.0V level	14	ENC2_B	Digital quadrature/incremental encoder 2, B channel, +5.0V level
15	HALL_WY	Digital Hall sensor input, +5.0V level	16	ENC2_N	Digital quadrature/incremental encoder 2, N channel, +5.0V level
17	GND	Signal and supply ground	18	UART_TX	UART interface, transmit line
19	+3.3V_OUT	+3.3V output rail	20	UART_RX	UART interface, receive line
21	REF_L	Left reference switch input, +5.0V level	22	ENC1_A	Digital quadrature/incremental encoder 1, A channel, +5.0V level
23	REF_H	Home reference switch input, +5.0V level	24	ENC1_B	Digital quadrature/incremental encoder 1, B channel, +5.0V level
25	REF_R	Right reference switch input, +5.0V level	26	ENC1_N	Digital quadrature/incremental encoder 1, N channel, +5.0V level
27	GND	Signal and supply ground	28	AENC_UX	(Future use) Analog encoder input, 0...+5V
29	CAN_H	CAN interface, diff. signal (non-inverting)	30	AENC_VN	(Future use) Analog encoder input, 0...+5V
31	CAN_L	CAN interface, diff. signal (inverting)	32	AENC_WY	(Future use) Analog encoder input, 0...+5V
33	SSI_ENC_DATA_P	SSI Encoder, positive terminal of differential data line	34	nCS_ENC	SPI / SSI Encoder, chip select signal, +5.0V level
35	SSI_ENC_DATA_N	SSI Encoder, negative terminal of differential data line	36	SPI_ENC_SCK	SPI Encoder, clock signal, +5.0V level
37	SSI_ENC_CLK_N	SSI Encoder, negative terminal of differential clock line	38	SPI_ENC_MOSI	SPI Encoder, MOSI signal, +5.0V level
39	SSI_ENC_CLK_P	SSI Encoder, positive terminal of differential clock line	40	SPI_ENC_MISO	SPI Encoder, MISO signal, +5.0V level

Table 3: TMCM-1636 I/O & Interface Connector



3.3 Brake Connector

The connector is of type [Molex Micro-Lock Plus 5055680271](#) (1.25mm pitch, single row, vertical, 2 pins). The mating connector is [Molex 5055650201](#) (1.25mm pitch, single row, 2 pins, positive lock, crimp housing). Use it with the following Micro-Lock Plus female crimp terminals: [Molex 5054311100](#) (1.25mm pitch, Au plating, 26-30 AWG).

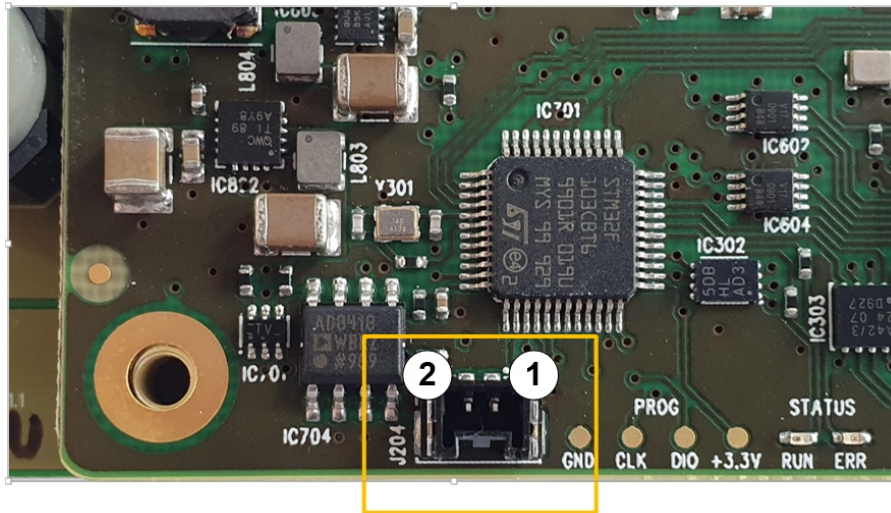

Figure 4: TCCM-1636 screw connectors

Terminal	Signal	Description
1	+VM	Motor supply voltage, voltage range depends on driver stage
2	BRAKE_CTRL	PWM controlled low-side output for driving solenoids. The drive current is configurable up to 1A.

Table 4: TCCM-1636 screw terminals



4 Interface Circuits

4.1 Supply Connection and Supply Buffering

TMCM-1636 includes only limited onboard capacitance. For high current applications additional capacitors must be placed close to the module power input to stabilize power supply. In addition, a regulated power supply is highly recommended.

NOTICE

Depending on your application make sure to add sufficient capacitors to the driver input to stabilize supply.

Low ESR electrolyte caps are recommended.

A maximum supply ripple of 0.25V (TBD) is allowed.

It is recommended to connect electrolytic capacitors of significant size to the power supply lines close to the TMCM-1636 !

Rule of thumb for size of electrolytic capacitor: $C = 1000 \frac{\mu F}{A} * I_{SUPPLY}$

The capacitors should be selected with regard to high ripple current rating. In addition to power stabilization (buffer) and filtering this added capacitor will also reduce any voltage spikes which might otherwise occur from a combination of high inductance power supply wires and the ceramic capacitors. In addition it will limit slew-rate of power supply voltage at the module. The low ESR of ceramic-only filter capacitors may cause stability problems with some switching power supplies.

4.2 General Purpose Inputs

The four general purpose inputs are optically isolated with opto-couplers. All GPI share the same COM connection.

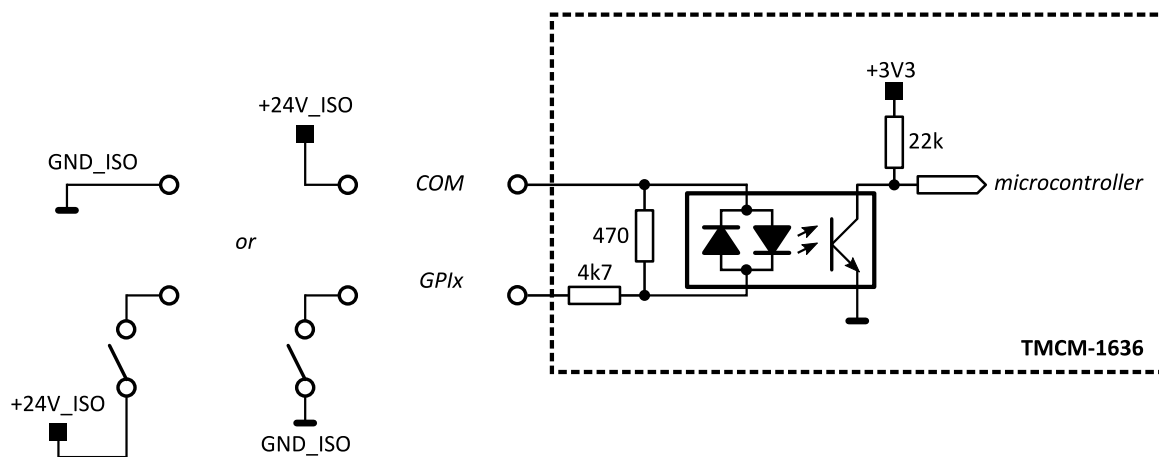

Figure 5: GPIx circuit

A separated / isolated supply may be used for the inputs – as indicated in the drawing (+24V_ISO and related GND_ISO) – but, same supply as for the TMCM-1636 can be used as well.



4.3 General Purpose Outputs

The two general purpose outputs are simple open drain outputs using n-channel FETs. The gates of the n-channel FETs are pulled low. There are no flyback diodes on the TMC1636.

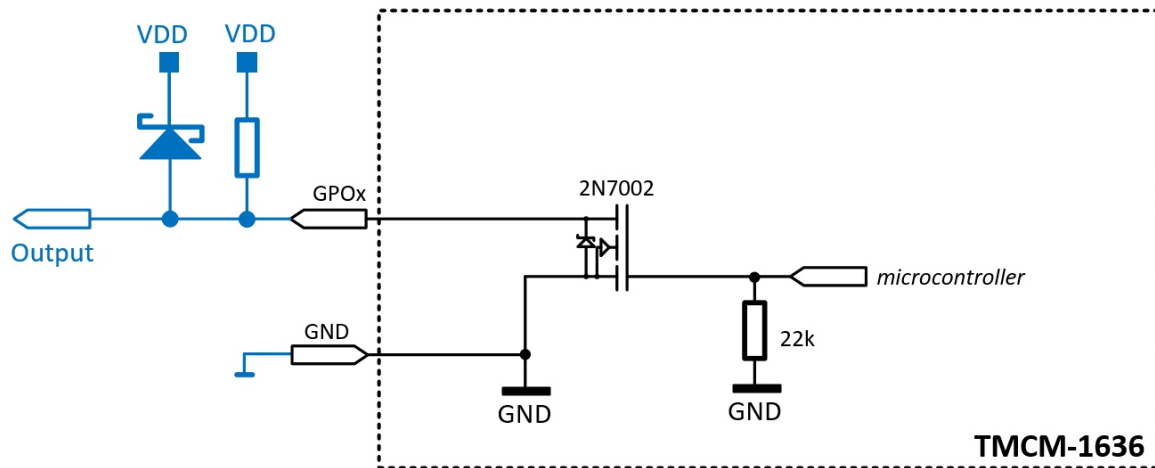

Figure 6: GPOx circuit

4.4 Analog Inputs

The two analog inputs go through a voltage divider and a simple filter before connecting to the microcontroller's ADC inputs.

The analog inputs allow for a 5V input range.

The input filter has a cut-off frequency of ca. 285Hz.

4.5 Reference Inputs

TMC1636 provides three reference inputs: Left, Right, and Home.

The input voltage range is 0V...5V.

The inputs have an internal pull-up to 5V.

An input filter has a cut-off frequency of ca. 34kHz

4.6 Brake Control Output

The brake control output BRAKE is a PWM controlled low-side output for driving solenoids. The drive current is configurable up to 1A.

4.7 Over-Voltage Protection Output

The over-voltage protection output OVP is a low-side output for external brake resistor. It can be used to prevent the supply rail from exceeding the maximum rated values in case of overvoltage conditions.



4.8 Feedback Interfaces

4.8.1 Incremental Quadrature Encoders 1 & 2

TMC-1636 provides two incremental quadrature encoder interfaces with A, B, and N signals each. The input voltage range is 0V...5V. The encoder inputs have an internal pull-up to 5V. An input filter has a cut-off frequency of ca. 1.6MHz.

4.8.2 Analog Encoder

TMC-1636 provides an analog encoder interface with U, V, and W signals. The input voltage range is 0V...5V. There are no pull resistors at this interface. An input filter has a cut-off frequency of ca. 70MHz.

4.8.3 Digital Hall Sensors

TMC-1636 provides a Hall signal interface. The input voltage range is 0V...5V. The Hall inputs have an internal pull-up to 5V. An input filter has a cut-off frequency of ca. 4kHz.

4.8.4 SPI-based Absolute Encoder

TMC-1636 provides an SPI master interface for external absolute position sensors or other peripherals (with custom firmware option). The SPI interface runs at 5V signal level.

4.8.5 RS422-based Absolute Encoder

TMC-1636 provides an RS422 interface for external absolute position sensors that use SSI or BiSS interface (depends on firmware option or custom firmware). TMC-1636 integrates the RS422 transceiver (TI THVD1451DRBR). The incoming RS422 data line (SSI_ENC_DATA_P and SSI_ENC_DATA_N) has an onboard termination of 120R.



5 LED Status Indicators

The TMCM-1636 has two on-boards LED status indicators.

LED	Description
RUN_LED	MCU/CANopen status LED, green
ERR_LED	MCU/CANopen error LED, red

Table 5: TMCM-1636 digital LED output signals

6 Communication

The following sections give some guidelines and best practices when setting up the communication bus systems supported by TMCM-1636.

6.1 CAN

For remote control and communication with a host system the TMCM-1636 provides a CAN bus interface. For proper operation the following items should be taken into account when setting up a CAN network:

1. **BUS STRUCTURE:**

The network topology should follow a bus structure as closely as possible. That is, the connection between each node and the bus itself should be as short as possible. Basically, it should be short compared to the length of the bus.

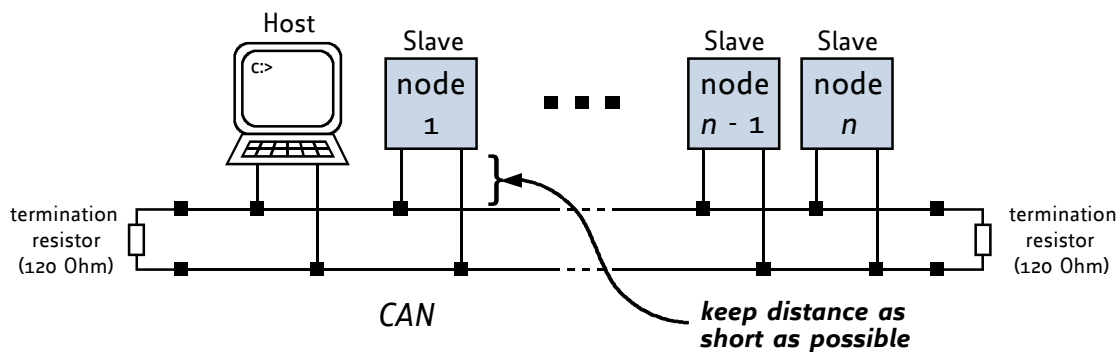

Figure 7: CAN bus structure with termination resistors

2. **BUS TERMINATION:**

Especially for longer buses and/or multiple nodes connected to the bus and/or high communication speeds, the bus should be properly terminated at both ends. The TMCM-1636 does not integrate any termination resistor. Therefore, 120 Ohm termination resistors at both ends of the bus have to be added externally.

3. **BUS TERMINATION:**

The bus transceiver used on the TMCM-1636 units or on the base board (TJA1042TK/3) supports at least 110 nodes under optimum conditions. Practically achievable number of nodes per CAN bus highly depend on bus length (longer bus -> less nodes) and communication speed (higher speed -> less nodes).



7 Operational Ratings and Characteristics

7.1 Absolute Maximum Ratings

Parameter	Symbol	Min	Abs. Max	Unit
Motor and supply voltage +24V version	$+VM$	+12	+30	V
Motor and supply voltage +48V version	$+VM$	+12	+58	V
Abs. max. RMS motor phase current +24V version	$I_{phaseRMS,MAX}$		60 ¹	A
Abs. max. RMS motor phase current +48V version	$I_{phaseRMS,MAX}$		60 ¹	A
Abs. max. environmental working temperature	T_A	-40	+85 ²	° C
Max current at +5V_OUT	$I_{OUT+5V,MAX}$		100	mA

NOTICE

Stresses above those listed under "Absolute Maximum Ratings" may cause permanent damage to the device. This is a stress rating only and functional operation of the device at those or any other conditions above those indicated in the operation listings of this specification is not implied. Exposure to maximum rating conditions for extended periods may affect device reliability.

7.2 Operational Ratings

Ambient temperature 25° C, if not stated otherwise.

Parameter	Symbol	Min	Typ	Max	Unit
Motor and supply voltage +24V version	$+VM$	+12	+24	+28	V
Motor and supply voltage +48V version	$+VM$	+12	+48	+52	V
continuous RMS Motor phase current +24V version	$I_{phaseRMS}$		30		A
continuous RMS Motor phase current +48V version	$I_{phaseRMS}$		20		A
Working temperature	T_A	-30		+60 ²	° C

7.3 I/O Ratings

Ambient temperature 25° C, if not stated otherwise.

Parameter	Symbol	Min	Typ	Max	Unit
Input voltage for analog inputs	V_{AIN}	0		5.0	V
GPI input voltage	V_{GPI}	0		24	V

¹This is the maximum current rating. This is not for continuous operation but depends on motor type, duty cycle, ambient temperature, and active/passive cooling measures.

²Working at high environmental temperatures may require additional cooling measures depending on duty cycle and maximum current/power draw.



GPO output voltage	V_{GPO}	0		24	V
GPO sink current	I_{GPO}	0		1	A
Brake control output voltage	V_{BRAKE}	0		+VM	V
Brake control sink current	I_{BRAKE}	0		1	A
Over-voltage protection output voltage	V_{OVP}	0		+VM	V
Over-voltage protection sink current	I_{OVP}	0		10	A
Incremental encoder input voltage	V_{ENC}	0		5	V
Analog encoder input voltage	V_{AENC}	0		5	V
Hall signal input voltage	V_{HALL}	0		5	V
Reference switch input voltage	V_{REF}	0		5	V
SPI Interface voltage	V_{SPI}	0		5	V
SSI (RS422) Interface voltage	V_{SSI}	-15		+15	V

Table 8: I/O ratings

7.4 Other Requirements

Specifications	Description or Value
Cooling	Free air or heat sink mounted depending on use case, required power output, and environmental temperature.
Working environment	Avoid dust, water, oil mist and corrosive gases, no condensation, no frosting

Table 9: Other Requirements and Characteristics



8 Figures Index

1 TMCM-1636 connectors / top view	5	5 GPIx circuit	10
2 TMCM-1636 screw connectors	6	6 GPOx circuit	11
3 TMCM-1636 I/O connector	7	7 CAN bus structure with termination	
4 TMCM-1636 screw connectors	9	resistors	13



9 Tables Index

1	TMCM-1636 Order Codes	4	8	I/O ratings	15
2	TMCM-1636 screw terminals	6	9	Other Requirements and Characteristics	15
3	TMCM-1636 I/O & Interface Connector	8	10	Hardware Revision	20
4	TMCM-1636 screw terminals	9	11	Document Revision	20
5	TMCM-1636 digital LED output signals	13			



10 Supplemental Directives

10.1 Producer Information

10.2 Copyright

TRINAMIC owns the content of this user manual in its entirety, including but not limited to pictures, logos, trademarks, and resources. © Copyright 2020 TRINAMIC. All rights reserved. Electronically published by TRINAMIC, Germany.

Redistributions of source or derived format (for example, Portable Document Format or Hypertext Markup Language) must retain the above copyright notice, and the complete Datasheet User Manual documentation of this product including associated Application Notes; and a reference to other available product-related documentation.

10.3 Trademark Designations and Symbols

Trademark designations and symbols used in this documentation indicate that a product or feature is owned and registered as trademark and/or patent either by TRINAMIC or by other manufacturers, whose products are used or referred to in combination with TRINAMIC's products and TRINAMIC's product documentation.

This Hardware Manual is a non-commercial publication that seeks to provide concise scientific and technical user information to the target user. Thus, trademark designations and symbols are only entered in the Short Spec of this document that introduces the product at a quick glance. The trademark designation /symbol is also entered when the product or feature name occurs for the first time in the document. All trademarks and brand names used are property of their respective owners.

10.4 Target User

The documentation provided here, is for programmers and engineers only, who are equipped with the necessary skills and have been trained to work with this type of product.

The Target User knows how to responsibly make use of this product without causing harm to himself or others, and without causing damage to systems or devices, in which the user incorporates the product.

10.5 Disclaimer: Life Support Systems

TRINAMIC Motion Control GmbH & Co. KG does not authorize or warrant any of its products for use in life support systems, without the specific written consent of TRINAMIC Motion Control GmbH & Co. KG.

Life support systems are equipment intended to support or sustain life, and whose failure to perform, when properly used in accordance with instructions provided, can be reasonably expected to result in personal injury or death.

Information given in this document is believed to be accurate and reliable. However, no responsibility is assumed for the consequences of its use nor for any infringement of patents or other rights of third parties which may result from its use. Specifications are subject to change without notice.

10.6 Disclaimer: Intended Use

The data specified in this user manual is intended solely for the purpose of product description. No representations or warranties, either express or implied, of merchantability, fitness for a particular purpose



or of any other nature are made hereunder with respect to information/specification or the products to which information refers and no guarantee with respect to compliance to the intended use is given.

In particular, this also applies to the stated possible applications or areas of applications of the product. TRINAMIC products are not designed for and must not be used in connection with any applications where the failure of such products would reasonably be expected to result in significant personal injury or death (safety-Critical Applications) without TRINAMIC's specific written consent.

TRINAMIC products are not designed nor intended for use in military or aerospace applications or environments or in automotive applications unless specifically designated for such use by TRINAMIC. TRINAMIC conveys no patent, copyright, mask work right or other trade mark right to this product. TRINAMIC assumes no liability for any patent and/or other trade mark rights of a third party resulting from processing or handling of the product and/or any other use of the product.

10.7 Collateral Documents & Tools

This product documentation is related and/or associated with additional tool kits, firmware and other items, as provided on the product page at: www.trinamic.com.



11 Revision History

11.1 Hardware Revision

Version	Date	Author	Description
V1.1	2020-01-06		Release Version

Table 10: Hardware Revision

11.2 Document Revision

Version	Date	Author	Description
V1.20	2020-06-08	SK/MM	Realease version

Table 11: Document Revision



X-ON Electronics

Largest Supplier of Electrical and Electronic Components

Click to view similar products for [Motor Drives](#) category:

Click to view products by [Analog Devices](#) manufacturer:

Other Similar products are found below :

[GMA02](#) [R7DBP02L](#) [1300920283](#) [ST10-S](#) [GMA11](#) [GMA20](#) [R88DUA03LAAC100V30W](#) [R88DUA12HA](#) [R88DUP03LAAC100V30W](#)
[STR2](#) [VFD002EL11A](#) [MFMCB0030GET](#) [MFECA0030EAM](#) [1302263150](#) [1300920078](#) [R88D-GN04H-ML2](#) [R88D-KT01H](#) [R7D-BP01H](#)
[R88D-KN04L-ECT](#) [70354063](#) [79294435](#) [27358015](#) [15275008](#) [ST5-Q-EN](#) [1SFA896103R1100](#) [1SFA896103R7000](#) [1SFA896112R1100](#)
[R88D-GP08H](#) [GNCF8-11](#) [KLC35BE](#) [ST10-Q-RN](#) [1302263161](#) [SV2D10-Q-AE](#) [VX5A1300](#) [R88A-CA1C005SF-E](#) [R88A-CR1B005NF-E](#)
[SEH 71-4B](#) [U-PKZ0\(400V50HZ\)](#) [LUCC12BL](#) [LUCC12FU](#) [LU9BN11L](#) [LULC08](#) [GV2P01](#) [UDS1UR6M50CANCZ183](#) [LC1D09M7](#)
[103H7126-1740](#) [103H7823-1741](#) [111.3761.20.00E](#) [111.3761.30.00E](#) [808070RAT250](#)