

Hardware Version V 1.10

HARDWARE MANUAL

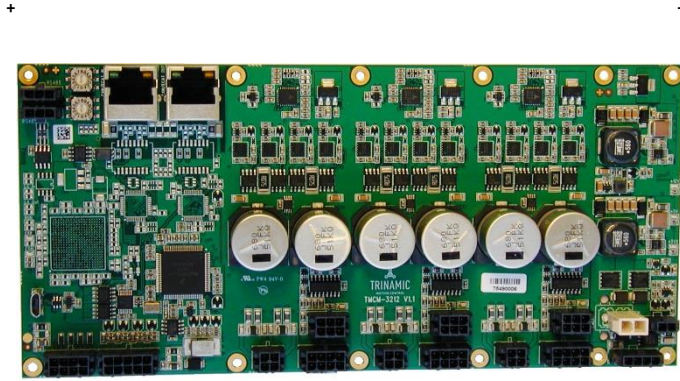

TMCM-3212

TMCM-3213

3-Axes Stepper
 Controller / Driver
 Up-to 3A RMS / 48V DC
 Encoder / HOME / STOP
 4x analog / digital inputs
 4x digital outputs
 Brake chopper support
 CAN, RS485, USB (TMCM-3212)
 EtherCAT™, USB (TMCM-3213)

dcStep™
 ■■■■■■■■



stallGuard2™

TRINAMIC Motion Control GmbH & Co. KG
 Hamburg, Germany

www.trinamic.com



TRINAMIC
 MOTION CONTROL

Table of contents

1	Life support policy	3
2	Features.....	4
3	Order codes.....	5
4	Mechanical and Electrical Interfacing	6
4.1	Dimensions and Mounting Holes	6
4.2	Board mounting considerations.....	7
5	Connectors of TMC3212 and TMC3213.....	8
5.1	TMC3212 Interface Brick	8
5.1.1	RS485 connector	9
5.1.2	CAN connector.....	9
5.1.3	USB connector	10
5.1.4	Input connector	10
5.1.5	Output connector.....	11
5.2	TMC3213 Interface Brick	11
5.2.1	EtherCAT™ connector.....	12
5.2.2	USB connector	12
5.2.3	Input connector	12
5.2.4	Output connector.....	13
5.3	TMC3212 + TMC3213 Driver Brick	14
5.3.1	Motor connector.....	14
5.3.2	REF / HOME connector.....	15
5.3.3	Encoder connector.....	15
5.4	TMC3212 + TMC3213 Power supply Brick	16
5.4.1	Power connector.....	17
5.4.2	Control connector.....	17
5.4.3	Resistor connector.....	18
5.5	Power supply	18
5.6	RS485.....	18
5.7	CAN	20
5.7.1	CAN adapter	21
5.8	General purpose outputs OUTo..3.....	22
6	Motor driver current	23
7	On Board LEDs.....	24
7.1	Power supply brick.....	24
7.2	TMC3212 Interface Brick	24
7.3	TMC3213 Interface Brick	25
8	Reset to Factory Default.....	25
9	Operational ratings	26
10	TMC3212 Functional Description.....	27
11	TMC3213 Functional Description.....	28
12	Revision History	29
12.1	Document revision	29
12.2	Hardware revision	29
13	References.....	29

1 Life support policy

TRINAMIC Motion Control GmbH & Co. KG does not authorize or warrant any of its products for use in life support systems, without the specific written consent of TRINAMIC Motion Control GmbH & Co. KG.

Life support systems are equipment intended to support or sustain life, and whose failure to perform, when properly used in accordance with instructions provided, can be reasonably expected to result in personal injury or death.

© TRINAMIC Motion Control GmbH & Co. KG 2015, 2016, 2017

Information given in this data sheet is believed to be accurate and reliable. However neither responsibility is assumed for the consequences of its use nor for any infringement of patents or other rights of third parties, which may result from its use.

Specifications are subject to change without notice.



2 Features

The TMCM-3212 / TMCM-3213 is a three axes controller/driver module for 2-phase bipolar stepper motors with separate encoder (differential) and HOME / STOP switch inputs for each axis. CAN, RS485 and USB (Micro-USB) interfaces are available on the TMCM-3212 and EtherCAT™ together with USB (Micro-USB) on the TMCM-3213 for communication. Furthermore the modules offer four analog / digital inputs and four digital outputs together with a brake chopper unit (supporting an external brake resistor) for supply voltage limitation when energy is fed back into the supply rail.

MAIN CHARACTERISTICS

Motion controller

- Motion profile calculation in real-time (linear and sixPoint™ ramps)
- On the fly alteration of motor parameters (e.g. position, velocity, acceleration)
- Dedicated HOME + STOP switch inputs (internal pull-ups)
- High performance microcontroller for overall system control and communication protocol handling

Bipolar stepper motor driver

- Up to 256 microsteps per full step
- High-efficient operation, low power dissipation
- Dynamic current control
- Integrated protection
- stealthChop™ for quiet operation and smooth motion
- dcStep™ feature for load dependent speed control
- stallGuard2™ feature for stall detection
- coolStep™ feature for reduced power consumption and heat dissipation

Interfaces

- TMCM-3212: CAN + RS485
- TMCM-3213: EtherCAT™
- USB full speed (12Mbit/s) device interface (Micro-USB)
- Differential encoder input per motor axis (3x)
- HOME, STOP_L, STOP_R switch inputs with internal pull-ups per motor axis (3x)
- 4 general purpose analog inputs (0..10V) or digital inputs (will accept +24V signals)
- 4 general purpose digital outputs (open-drain, 500mA each)

Software

- TMCL™ remote (direct mode) and standalone operation with memory for up to 1024 TMCL commands
- TMCM-3212: TMCL and CANopen firmware available
- TMCM-3213: CoE (CANopen over EtherCAT™) firmware available

Electrical data

- Supply voltage: nom. +24V and +48V with +17V ... +53V supply voltage operating range
- Motor current: up to 3A RMS (programmable)

Mechanical data

- Board size: 215mm x 100mm, overall height 21mm max. (incl. pcb but, without mating connectors and cables)
- 12x M3 mounting holes (optional)

Please see separate TMCM-3212 / TMCM-3213 Software / Firmware documentation for additional information regarding programming and communication protocol.

3 Order codes

The TMCM-3212 unit is available with two different firmware options:

Order code	Description	Size of unit
TMCM-3212-TMCL	3-axes controller / driver up-to 3A RMS / +48V, CAN + RS485 + USB with standard TMCL firmware	215mm x 100mm x 21mm
TMCM-3212-CANopen	3-axes controller / driver up-to 3A RMS / +48V, CAN + RS485 + USB with CANopen firmware	215mm x 100mm x 21mm

Table 3.1: TMCM-3212 order code

The TMCM-3213 unit is available as:

Order code	Description	Size of unit
TMCM-3213-CoE	3-axes controller / driver up-to 3A RMS / +48V, EtherCAT™ + USB with CANopen over EtherCAT™ firmware	215mm x 100mm x 21mm

Table 3.2: TMCM-3213 order code

A cable loom is available, also:

Order code	Description
TMCM-G4-CABLE	<p>Cable loom for TMCM-6210/6211, TMCM-6212/6213, TMCM-3212/3213, TMCM-3214/3215, TMCM-3312/3313 and TMCM-3314/3315. Contains:</p> <ul style="list-style-type: none"> - 1x cable loom for RS485 connector (3212) - 1x standard CAT5 cable with 2x RJ45 for CAN / EtherCAT™ (3212/3213) - 1x RJ45-2-DSUB_G4_V10 adapter (for CAN RJ45 <-> D-SUB translation) (3212) - 1x Micro-USB cable (3212/3213) - 1x cable loom for INPUTs connector (3212/3213) - 1x cable loom for OUTPUTs connector (3212/3213) - 6x cable loom for MOTOR connector (small) (3x required for 3212/3213) - 3x cable loom for MOTOR connector (big) - 6x cable loom for ENCODER connector (3x required for 3212/3213) - 6x cable loom for REF / HOME connector (3x required for 3212/3213) - 1 cable loom for POWER connector (small) (3212/3213) - 1x cable loom for POWER connector (big) - 1x cable loom for CONTROL connector (3212/3213) - 1x cable loom for RESISTOR connector (3212/3213)

Please note: there is one cable loom available for a complete family of modules in order to speed-up initial setup of these modules. The family consists of these currently planned / available modules: TMCM-6210/6211, TMCM-6212/6213, TMCM-3212/3213, TMCM-3214/3215, TMCM-3312/3313 and TMCM-3314/3315. Not all cables are required for all modules – some cable will fit or will be helpful for some modules, only. Module numbers in parenthesis behind each cable in the table above indicate whether the particular part of the cable loom can be used with the TMCM-3212 and / or TMCM-3213.

4 Mechanical and Electrical Interfacing

4.1 Dimensions and Mounting Holes

The dimensions of the TMC3212 and TMC3213 controller/driver board are approx. 215mm x 100mm x 21mm. Maximum component height (height above PCB level) without mating connectors is around 17mm above PCB level and 2mm below PCB level. There are 12 mounting holes for M3 screws (3.2mm diameter) altogether for mounting the PCB.

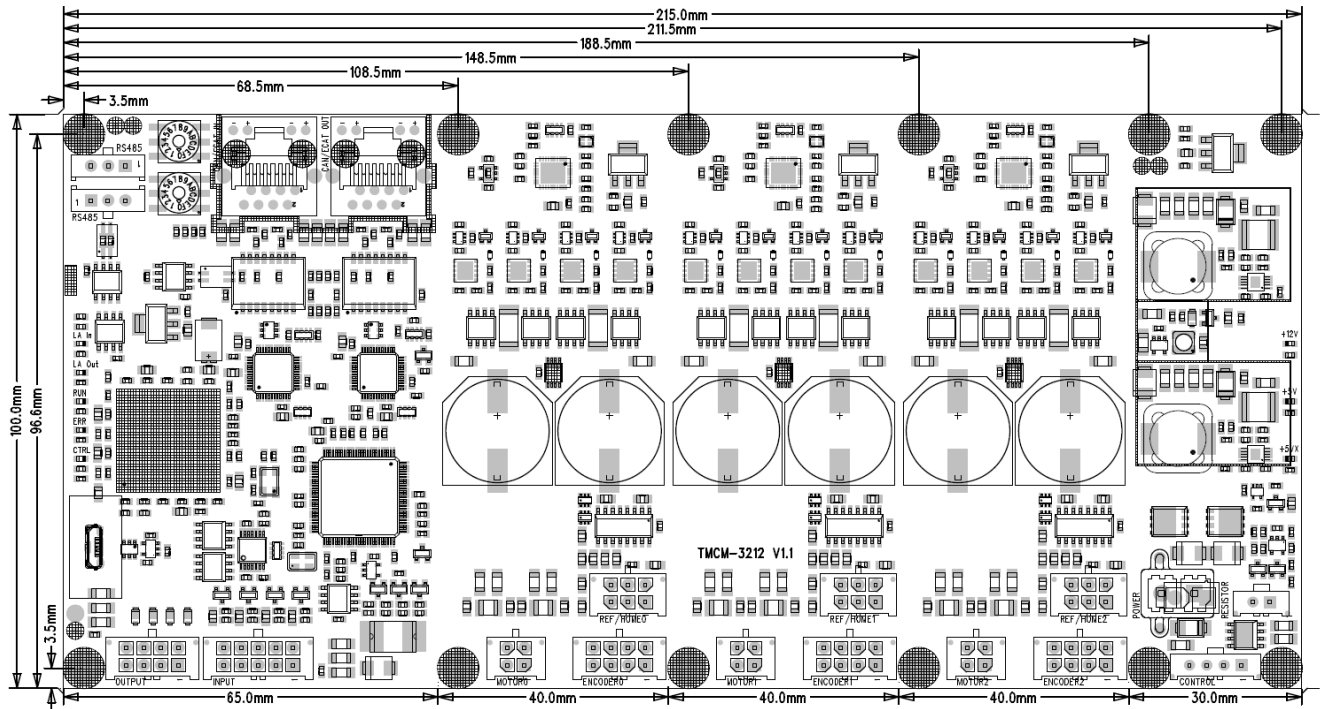

Figure 4.1 Dimension of TMC3212 / TMC3213 and position of mounting holes

Please note: TMC3212 and TMC3213 share the same PCB with different assembly options regarding the interface section. Dimensions, mounting holes and board mounting considerations (see chapter below) are the same for both boards.

4.2 Board mounting considerations

The TMC3212 / TMC3213 offer 12 metal plated mounting holes. One hole (lower right) is connected to on-board system ground (connected to power supply input ground) via $1M$ ($500VDC$) \parallel $1nF$ ($1kV$). The same combination of resistor and capacitor is used for connecting the RJ45 shield ground (connector enclosure) to power supply input ground (see figure 4.2).

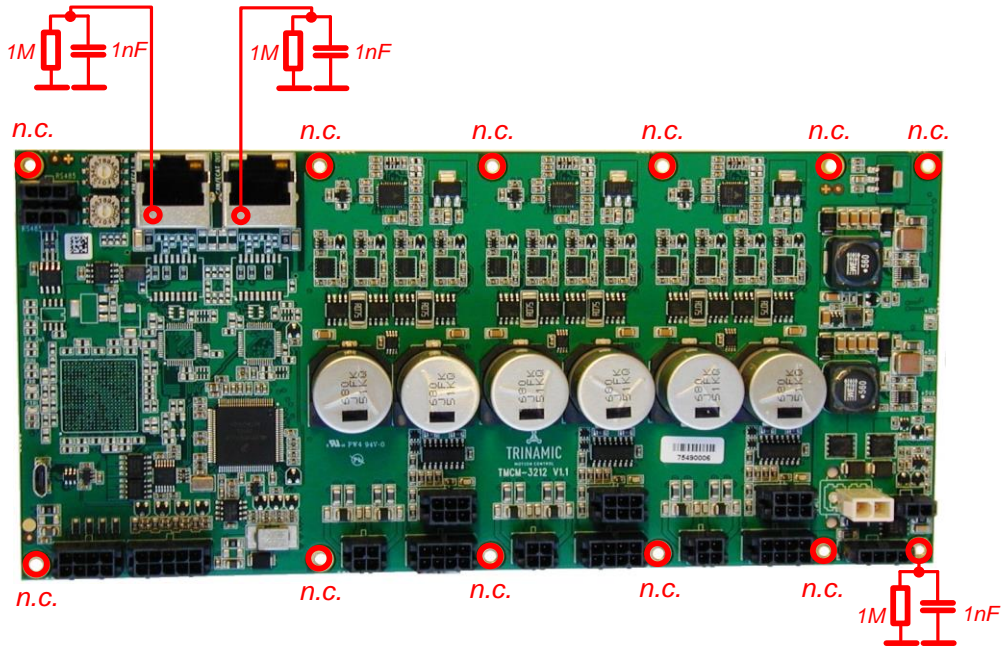

Figure 4.2 TCM-3212 / TCM-3213 mounting hole connections

All other mounting holes are electrically isolated. Please note that not all holes have to be used for mounting the pcb. At least the mounting holes in all four corners and two in the middle (6 altogether) should be used to ensure adequate support of the pcb when inserting / removing connectors in order to avoid significant bending of the pcb.

In any case: please remove / attach mating connectors carefully – supporting the pcb if necessary!

5 Connectors of TMCM-3212 and TMCM-3213

The TMCM-3212 and TMCM-3213 are two members of a new family of modules with a modular architecture composed of so called "bricks".

The TMCM-3212 and TMCM-3213 consist of one interface brick, three single-axis stepper motor controller / driver bricks and one supply brick. With the TMCM-3212 the interface brick offers CAN and RS485 interfaces while with the TMCM-3213 the EtherCAT™ option is assembled instead. All other bricks are the same for both modules.

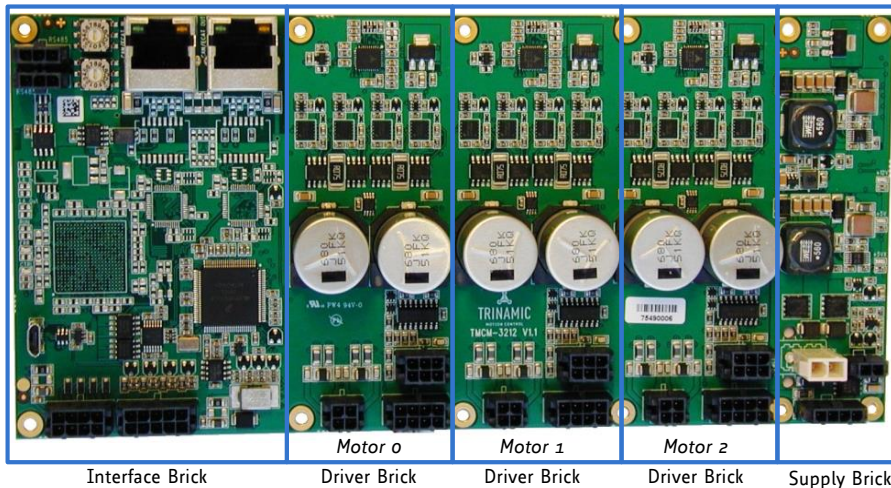

Figure 5.1 different bricks used for the TMCM-3212 / TMCM-3213

5.1 TMCM-3212 Interface Brick

The interface brick of the TMCM-3212 offers RS485, CAN and USB interfaces for communication, four general purpose analog inputs (which can be used as digital inputs as well) and four open-drain outputs.

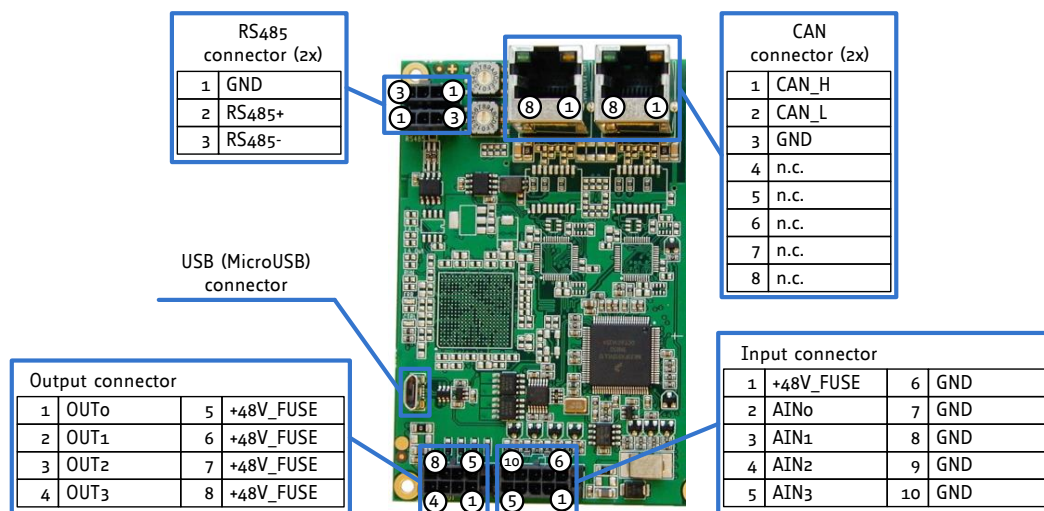

Figure 5.2 TMCM-3212 interface brick

Connector and mating connector overview:

Label	Connector type	Mating connector type
RS485	Molex MicroFit™, 436500315 1x4 pin header, 3mm pitch	Molex MicroFit™, Housing: 43645-0300 Contacts: 43030-0007
CAN	RJ45 plug connector	e.g. Standard CAT 5 / CAT 5e cables may be used
USB	Micro-USB connector, type B (USB device interface)	Standard Micro-USB
Inputs	Molex MicroFit™, 430451012 2x5 pin header, 3mm pitch	Molex MicroFit™, Housing: 43025-1000 Contacts: 43030-0007
Outputs	Molex MicroFit™, 430450812 2x4 pin header, 3mm pitch	Molex MicroFit™, Housing: 43025-0800 Contacts: 43030-0007

Table 5.1 TMC3212 interface brick: connectors and mating connectors

5.1.1 RS485 connector

There are two RS485 connectors on the board with the same pin assignment – pins directly connected to each other. The second connector may be used for attaching a bus termination resistor to the RS485 bus (there is no termination resistor on-board) or for further distribution of the RS485 bus signals to other RS485 communication nodes while maintaining a proper bus structure.

A three pin Molex MicroFit™ connector (Molex part no. 436500315) is used for RS485 connection. Mating connector housing e.g. Molex 43645-0300, contacts Molex 43030-0007. Please note that there are alternative options available from Molex for both, housing and contacts.

	Pin	Label	Direction	Description
	1	GND	Power	Supply and signal ground
	2	RS485+	Bi-directional	RS485 interface, diff. signal (non-inverting)
	3	RS485-	Bi-directional	RS485 interface, diff signal (inverting)

Table 5.1: Interface Brick: RS485 connector

5.1.2 CAN connector

There are two CAN connectors on the board with the same pin assignment – pins directly connected to each other. The second one may be used for attaching a bus termination resistor to the RS485 bus (there is no termination resistor on-board) or for further distribution of the CAN bus signals to other CAN nodes while maintaining a proper bus structure.

A standard RJ45 plug connector is used for CAN communication. Standard CAT cables (e.g. CAT 5, non-crossing) might be used for connection. Pin assignment of the RJ45 is based on the CiA 303-1 recommendation.

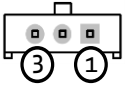
	Pin	Label	Direction	Description
	1	CAN_H	Bi-Directional	CAN interface, diff signal (non-inverting)
	2	CAN_L	Bi-directional	CAN interface, diff signal (inverting)
	3	GND	Power	Supply and signal ground
	4	n.c.		
	5	n.c.		
	6	n.c.		
	7	n.c.		
	8	n.c.		

Table 5.2 Interface Brick: CAN connector

5.1.3 USB connector

The TMCM-3212 / TMCM-3213 offers a Micro USB connector (Type B, device interface) for communication. The USB interface supports USB high speed communication (12Mbit/s). With USB attached the digital logic part of the TMCM-3212 / TMCM-3213 will be supplied via USB (USB powered mode) if there is no main supply available. This mode may be used for firmware-updates, TMCL-program download or parameter settings etc. (requires USB connection, only). Please note that in USB stand-alone mode (main board supply available) the board might still draw current from the USB supply – depending on the voltage level of the USB +5V and the on-board generated +5V.

5.1.4 Input connector

The TMCM-3212 / TMCM-3213 offer four analog inputs (nom. 0..10V range) which may be used as digital inputs, also (+24V tolerant).

The four inputs are available via one 10 pin Molex MicroFit™ connector (Molex part no. 430451012). Mating connector housing e.g. Molex 43025-1000, contacts Molex 43030-0007. Please note that there are alternative options available from Molex for both, mating housing and contacts.

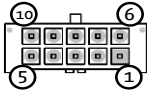

Pin	Label	Direction	Description
1	+48V_FUSE	Power output	Connected via fuse (polyfuse) to power supply input (+48V_LOGIC supply input on power control connector). Max. output current (together with all +48V_FUSE supply outputs on output connector: 500mA / polyfuse protected)
2	AIN0	Input	Analog input channel 0 (nom. 0..10V)
3	AIN1	Input	Analog input channel 1 (nom. 0..10V)
4	AIN2	Input	Analog input channel 2 (nom. 0..10V)
5	AIN3	Input	Analog input channel 3 (nom. 0..10V)
6	GND	Power	Supply and signal ground
7	GND	Power	Supply and signal ground
8	GND	Power	Supply and signal ground
9	GND	Power	Supply and signal ground
10	GND	Power	Supply and signal ground

Table 5.3: Interface Brick: Input connector

5.1.5 Output connector

The TMCM-3212 / TMCM-3213 offer four digital outputs (open-drain). The four outputs are available via one 8 pin Molex MicroFit™ connector (Molex part no. 43045-0812). Mating connector housing e.g. Molex 43025-0800, contacts Molex 43030-0007. Please note that there are alternative options available from Molex for both, mating housing and contacts.

Pin	Label	Direction	Description
1	AOUT ₀	Output	Open-drain output
2	AOUT ₁	Output	Open-drain output
3	AOUT ₂	Output	Open-drain output
4	AOUT ₃	Output	Open-drain output
5	+48V_FUSE	Power output	Connected via fuse (polyfuse) to power supply input (+48V_LOGIC supply input on power control connector). Max. output current (together with all +48V_FUSE supply outputs on output connector: 500mA / polyfuse protected)
6	+48V_FUSE	Power output	Connected via fuse (polyfuse) to power supply input (+48V_LOGIC supply input on power control connector). Max. output current (together with all +48V_FUSE supply outputs on output connector: 500mA / polyfuse protected)
7	+48V_FUSE	Power output	Connected via fuse (polyfuse) to power supply input (+48V_LOGIC supply input on power control connector). Max. output current (together with all +48V_FUSE supply outputs on output connector: 500mA / polyfuse protected)
8	+48V_FUSE	Power output	Connected via fuse (polyfuse) to power supply input (+48V_LOGIC supply input on power control connector). Max. output current (together with all +48V_FUSE supply outputs on output connector: 500mA / polyfuse protected)

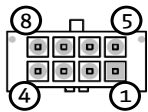

Table 5.4: Interface Brick: Output connector

5.2 TMCM-3213 Interface Brick

The interface brick of the TMCM-3213 offers EtherCAT™ and USB interfaces for communication, four general purpose analog inputs (which can be used as digital inputs as well) and four open-drain outputs.

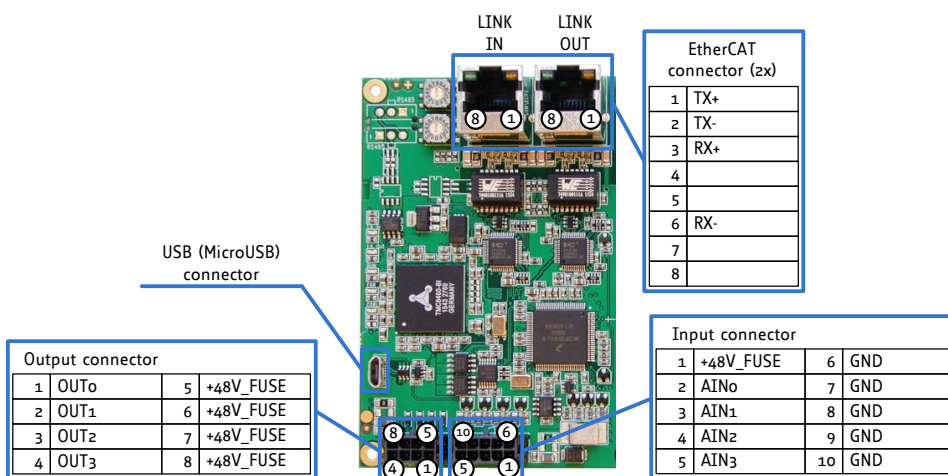

Figure 5.3 TMCM-3213 interface brick

Connector and mating connector overview:

Label	Connector type	Mating connector type
EtherCAT™	RJ45 plug connector	e.g. Standard CAT 5 / CAT 5e cables suitable for 100Mbit/s Ethernet
USB	Micro-USB connector, type B (USB device interface)	Standard Micro-USB
Inputs	Molex MicroFit™, 43045-1012 2x5 pin header, 3mm pitch	Molex MicroFit™, Housing: 43025-1000 Contacts: 43030-0007
Outputs	Molex MicroFit™, 43045-0812 2x4 pin header, 3mm pitch	Molex MicroFit™, Housing: 43025-0800 Contacts: 43030-0007

Table 5.5: TMCM-3213 interface brick: connectors and mating connectors

5.2.1 EtherCAT™ connector

There are two EtherCAT™ connectors on the board – one for LINK IN (towards / coming from EtherCAT™ master) and one for LINK OUT (for connecting further slaves) connection.

A standard RJ45 plug connector (as used for 10/100Mbit/s Ethernet) is used for EtherCAT™ communication. Standard CAT cables suitable for 100Mbit/s Ethernet (e.g. CAT 5 / 5e etc.) might be used for connection. The PHYs used on the TMCM-3213 support auto MDI-X – therefore, TX and RX signals on the connector might be exchanged – e.g. cables with straight-through pin-assignment can be used.

	Pin	Label	Direction	Description
	1	TX+	Output	Transmit data output, differential, non-inverting
	2	TX-	Output	Transmit data output, differential, inverting
	3	RX+	Input	Receive data input, differential, non-inverting
	4			
	5			
	6	RX-	Input	Receive data input, differential, inverting
	7			
	8			

Table 5.6: TMCM-3213 Interface Brick: EtherCAT™ connector

5.2.2 USB connector

The TMCM-3212 / TMCM-3213 offers a Micro USB connector (Type B, device interface) for communication. The USB interface supports USB high speed communication (12Mbit/s). With USB attached the digital logic part of the TMCM-3212 / TMCM-3213 will be supplied via USB (USB powered mode) if there is no main supply available. This mode may be used for firmware-updates, TMCL-program download or parameter settings etc. (requires USB connection, only). Please note that in USB stand-alone mode (main board supply available) the board might still draw current from the USB supply – depending on the voltage level of the USB +5V and the on-board generated +5V.

5.2.3 Input connector

The TMCM-3212 / TMCM-3213 offer four analog inputs (nom. 0..10V range) which may be used as digital inputs, also (+24V tolerant).

The four inputs are available via one 10 pin Molex MicroFit™ connector (Molex part no. 430451012). Mating connector housing e.g. Molex 43025-1000, contacts Molex 43030-0007. Please note that there are alternative options available from Molex for both, mating housing and contacts.

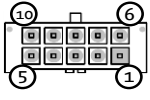

Pin	Label	Direction	Description
1	+48V_FUSE	Power output	Connected via fuse (polyfuse) to power supply input (+48V_LOGIC supply input on power control connector). Max. output current (together with all +48V_FUSE supply outputs on output connector: 500mA / polyfuse protected)
2	AIN0	Input	Analog input channel 0 (nom. 0..10V)
3	AIN1	Input	Analog input channel 1 (nom. 0..10V)
4	AIN2	Input	Analog input channel 2 (nom. 0..10V)
5	AIN3	Input	Analog input channel 3 (nom. 0..10V)
6	GND	Power	Supply and signal ground
7	GND	Power	Supply and signal ground
8	GND	Power	Supply and signal ground
9	GND	Power	Supply and signal ground
10	GND	Power	Supply and signal ground

Table 5.7: Interface Brick: Input connector

5.2.4 Output connector

The TMC3212 / TMC3213 offer four digital outputs (open-drain). The four outputs are available via one 8 pin Molex MicroFit™ connector (Molex part no. 43045-0812). Mating connector housing e.g. Molex 43025-0800, contacts Molex 43030-0007. Please note that there are alternative options available from Molex for both, mating housing and contacts.

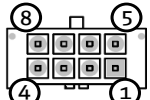

Pin	Label	Direction	Description
1	OUT0	Output	Open-drain output channel 0
2	OUT1	Output	Open-drain output channel 1
3	OUT2	Output	Open-drain output channel 2
4	OUT3	Output	Open-drain output channel 3
5	+48V_FUSE	Power output	Connected via fuse (polyfuse) to power supply input (+48V_LOGIC supply input on power control connector). Max. output current (together with all +48V_FUSE supply outputs on output connector: 500mA / polyfuse protected)
6	+48V_FUSE	Power output	Connected via fuse (polyfuse) to power supply input (+48V_LOGIC supply input on power control connector). Max. output current (together with all +48V_FUSE supply outputs on output connector: 500mA / polyfuse protected)
7	+48V_FUSE	Power output	Connected via fuse (polyfuse) to power supply input (+48V_LOGIC supply input on power control connector). Max. output current (together with all +48V_FUSE supply outputs on output connector: 500mA / polyfuse protected)
8	+48V_FUSE	Power output	Connected via fuse (polyfuse) to power supply input (+48V_LOGIC supply input on power control connector). Max. output current (together with all +48V_FUSE supply outputs on output connector: 500mA / polyfuse protected)

Table 5.8: Interface Brick: Output connector

5.3 TMCM-3212 + TMCM-3213 Driver Brick

The driver brick of the TMCM-3212 and TMCM-3213 offers one output for bipolar stepper motors with up-to 3A RMS / 4.2A peak motor current (programmable), separate HOME + REFL and REFR inputs and encoder inputs (for incremental ABN encoders with differential signals) for the related motor axis. The TMCM-3212 and TMCM-3213 offer three such driver bricks, supporting 3 stepper motors altogether.

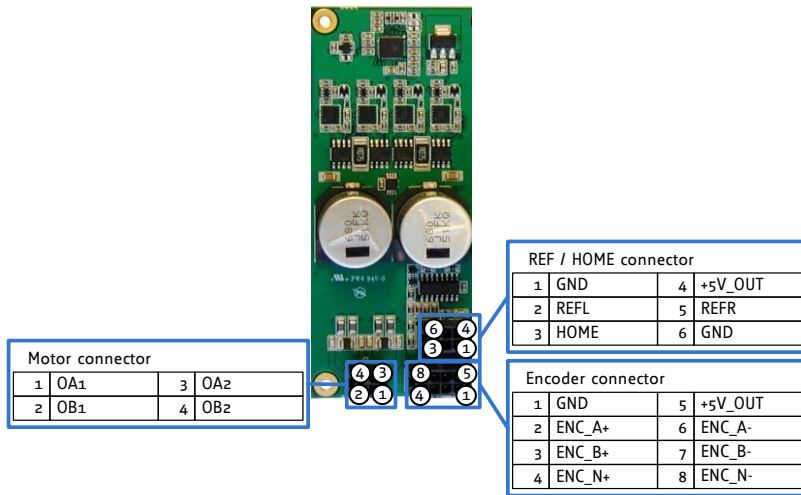

Figure 5.4 TMCM-3212 + TMCM-3213 Driver Brick

Label	Connector type	Mating connector type
Motor	Molex MicroFit Jr.™, 43045-0412 2x2 pin header, 3mm pitch	Molex MicroFit Jr.™, Housing: 43025-0400 Contacts: 43030-0007
REF / HOME	Molex MicroFit™, 43045-0612 2x3 pin header, 3mm pitch	Molex MicroFit™, Housing: 43025-0600 Contacts: 43030-0007
Encoder	Molex MicroFit™, 43045-0812 2x4 pin header, 3mm pitch	Molex MicroFit™, Housing: 43025-0800 Contacts: 43030-0007

Table 5.9 TMCM-3212 and TMCM-3213 Driver brick: connectors and mating connectors

5.3.1 Motor connector

Each motor (with two coils A + B and four connecting wires) can be connected via one 4 pin Molex MicroFit™ connector (Molex part no. 43045-0412). Mating connector housing e.g. Molex 43025-0400, contacts Molex 43030-0007. Please note that there are alternative options available from Molex for both, mating housing and contacts.

	Pin	Label	Direction	Description
	1	OA1	Output	Motor coil A
	2	OB1	Output	Motor coil B
	3	OA2	Output	Motor coil A
	4	OB2	Output	Motor coil B

Table 5.10: Driver Brick: Motor connector

CAUTION**Do not connect or disconnect motor during operation!**

Motor cable and motor inductivity might lead to voltage spikes when the motor is disconnected / connected while energized. These voltage spikes might exceed voltage limits of the driver MOSFETs and might permanently damage them. Therefore, always switch off and / or disconnect power supply before connecting / disconnecting the motor.

5.3.2 REF / HOME connector

There is one REF / HOME connector per driver brick – one for each motor axis. HOME, REFL and / or REFR switches may be connected via one 6 pin Molex MicroFit™ connector (Molex part no. 43045-0612). Mating connector housing e.g. Molex 43025-0600, contacts Molex 43030-0007. Please note that there are alternative options available from Molex for both, mating housing and contacts.

	Pin	Label	Direction	Description
	1	GND	Power	Supply and signal ground
	2	REFL	Input	REF left / Left stop switch input. Internal pull-up (5k6) to +5V. External switch to ground may be connected or up-to +5V push-pull signal.
	3	HOME	Input	Home switch input. Internal pull-up (5k6) to +5V. External switch to ground may be connected or up-to +5V push-pull signal.
	4	+5V_OUT	Power output	Connected to the on-board +5V auxiliary DC/DC converter. All +5V_OUT power supply outputs together on the 3 REF / HOME and 3 Encoder connectors may draw up-to 1A (e.g. 100mA per encoder and up-to 20mA per REF / HOME switch).
	5	REFR	Input	REF right / Right stop switch input. Internal pull-up (5k6) to +5V. External switch to ground may be connected or up-to +5V push-pull signal.
	6	GND	Power	Supply and signal ground

Table 5.11: Driver Brick: REF / HOME connector

5.3.3 Encoder connector

There is one Encoder connector available per driver brick – one for each motor axis. Incremental A/B/N encoders with differential encoder signals are supported. The TMC3212 / TMC3213 offer on-board differential line receivers (AM26LV32 or equivalent) with 120R termination resistor per differential signal pair. Differential encoder signals may be connected via one 8 pin Molex MicroFit™ connector (Molex part no. 43045-0812). Mating connector housing e.g. Molex 43025-0800, contacts Molex 43030-0007. Please note that there are alternative options available from Molex for both, mating housing and contacts.

Pin	Label	Direction	Description
1	GND	Power	Supply and signal ground
2	ENC_A+	Input	Differential input of encoder channel A, non-inverting input
3	ENC_B+	Input	Differential input of encoder channel B, non-inverting input
4	ENC_N+	Input	Differential input of encoder null / zero channel, non-inverting input
5	+5V_OUT	Power output	Connected to the on-board +5V auxiliary DC/DC converter. All +5V_OUT power supply outputs together on the 3 REF / HOME and 3 Encoder connectors may draw up-to 1A (e.g. 100mA per encoder and up-to 20mA per REF / HOME switch).
6	ENC_A-	Input	Differential input of encoder channel A, inverting input
7	ENC_B-	Input	Differential input of encoder channel B, inverting input
8	ENC_N-	Input	Differential input of encoder null / zero channel, inverting input

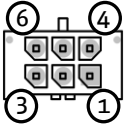
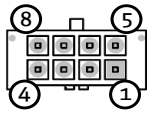

Table 5.12: Driver Brick: Encoder connector

5.4 TMCM-3212 + TMCM-3213 Power supply Brick

The power supply brick of the TMCM-3212 and TMCM-3213 offers one main supply input via the Power connector, separate logic supply input as an option and a hardware driver stage enable input on the Control connector and connection for an external brake connector with the on-board brake chopper circuit.

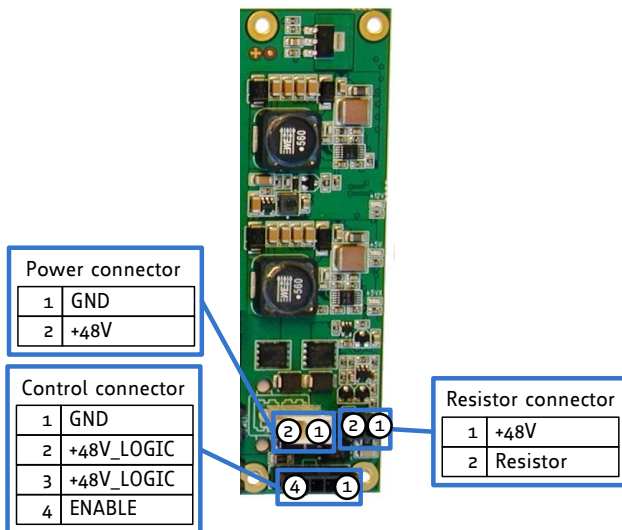

Figure 5.5: TMCM-3212 + TMCM-3213 Power supply Brick

Connector and mating connector overview:

Label	Connector type	Mating connector type
Power	Molex MiniFit Jr.™, 39-28-1023 1x2 pin header, 4.2mm pitch	Molex MiniFit Jr.™, Housing: 39-01-2020 Contacts: 39-00-0039
Control	Molex MicroFit™, 43650-0415 1x4 pin header, 3mm pitch	Molex MicroFit™, Housing: 43645-0400 Contacts: 43030-0007
Resistor	Molex MicroFit™, 43650-0215 2x4 pin header, 3mm pitch	Molex MicroFit™, Housing: 43645-0200 Contacts: 43030-0007

Table 5.13 TMCM-3212 and TMCM-3213 Power supply brick: connectors and mating connectors

5.4.1 Power connector

A two pin Molex MiniFit Jr.™ connector (Molex part no. 39-28-1023) is available for power supply connection. Mating connector housing e.g. Molex 39-01-2020, contacts Molex 39-00-0039. Please note that there are alternative options available from Molex for both, housing and contacts.

	Pin	Label	Direction	Description
	1	GND	Power	Supply and signal ground
2	+48V	Power supply input	Power supply input. +24V ... +48V +/- 10% regulated power supply input. Supply input for all six motor driver stages and logic supply.	

Table 5.14: Power supply Brick: Power connector

CAUTION
<p>Always keep the power supply voltage (+48V) below the upper limit of 53V! Otherwise the driver electronics will be seriously damaged. Especially, when the selected operating voltage is near the upper limit a regulated power supply is highly recommended.</p>
<p>Always keep the logic power supply voltage (+48V_LOGIC) above or equal to the main power supply! Otherwise the on-board electronics (diode connection between +48V main power supply input and +48V logic supply input) might be seriously damaged.</p>

5.4.2 Control connector

A four pin Molex MicroFit™ connector (Molex part no. 436500415) is used for the driver stage enable signal and optional separate logic supply input. Mating connector housing e.g. Molex 43645-0400, contacts Molex 43030-0007. Please note that there are alternative options available from Molex for both, housing and contacts.

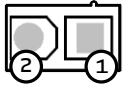
	Pin	Label	Direction	Description
	1	GND	Power	Supply and signal ground
	2	+48V_LOGIC	Power supply input	Separate logic supply input. May be used in order to keep digital / logic part alive while driver stage is not supplied (Power supply input via Power connector either switched off or disconnected).
	3	+48V_LOGIC	Power supply input	Same as Pin 2.
4	ENABLE	Input	Driver stage enable input (logic high). Maybe connected to pin 3 / +48V_LOGIC in order to enable driver.	

Table 5.15: Power supply brick: Control connector

CAUTION
<p>Always keep the digital logic power supply voltage (+48V_LOGIC) below the upper limit of 53V! Otherwise the on-board electronics might be seriously damaged. Especially, when the selected operating voltage is near the upper limit a regulated power supply is highly recommended.</p>
<p>Always keep the logic power supply voltage (+48V_LOGIC) above or equal to the main power supply (on the Power supply connector)! Otherwise the on-board electronics (diode connection between +48V main power supply input and +48V logic supply input) might be seriously damaged.</p>

5.4.3 Resistor connector

The TMC3212 and TMC3213 offer a brake chopper in hardware for limiting supply voltage in case energy is fed back from motor / driver stage into the supply rail. A two pin Molex MicroFit™ connector (Molex part no. 43650-0215) is used for connecting an external brake resistor. Mating connector housing e.g. Molex 43645-0200, contacts Molex 43030-0007. Please note that there are alternative options available from Molex for both, housing and contacts.

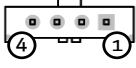
	Pin	Label	Direction	Description
	1	+48V	Power supply input	Connected to power supply input of Power connector.
	2	Resistor	Output	Brake chopper output. An external power resistor should be connected between Pin 1 and Pin 2 of this connector.

Table 5.16: Power supply brick: Resistor connector

5.5 Power supply

For proper operation care has to be taken with regard to power supply concept and design. The TMC3212 / TMC3213 includes about 4000µF/63V of supply filter capacitors. In addition, the module includes a 48V suppressor diode for over-voltage protection. Nevertheless, it is important to make sure that supply voltage will not rise beyond the upper limit of +53V! Please note: during motor deceleration the driver stage might feedback energy from the motor into the supply rail and supply voltage might increase. In order to limit the supply voltage a brake chopper circuit has been included on the board. When activated in software and together with an external power resistor this circuit will limit the supply voltage.

CAUTION

Always keep the power supply voltage (+48V) below the upper limit of 53V!

Otherwise the on-board electronics might be seriously damaged. Especially, when the selected operating voltage is near the upper limit a regulated power supply is highly recommended. In addition, the on-board brake chopper may be used together with an external power resistor connected to the Resistor connector in order to limit supply voltage.

Always keep the digital logic power supply voltage (+48V_LOGIC) below the upper limit of 53V!

Otherwise the on-board electronics might be seriously damaged. Especially, when the selected operating voltage is near the upper limit a regulated power supply is highly recommended.

Always keep the logic power supply voltage (+48V_LOGIC) above or equal to the main power supply (on the Power supply connector)!

Otherwise the on-board electronics (diode connection between +48V main power supply input and +48V logic supply input) might be seriously damaged.

There is limited reverse polarity protection, only!

The module will short any reversed supply voltage.

5.6 RS485

For remote control and communication with a host system the TMC3212 provides a two wire RS485 bus interface. For proper operation the following items should be taken into account when setting up an RS485 network:

1. **BUS STRUCTURE:**

The network topology should follow a bus structure as closely as possible. That is, the connection between each node and the bus itself should be as short as possible. Basically, it should be short compared to the length of the bus. The TMC3212 offers two connectors which are connected directly to each other and the on-board RS485 transceiver. Using both connectors for passing through the bus will help with keeping a proper bus topology.

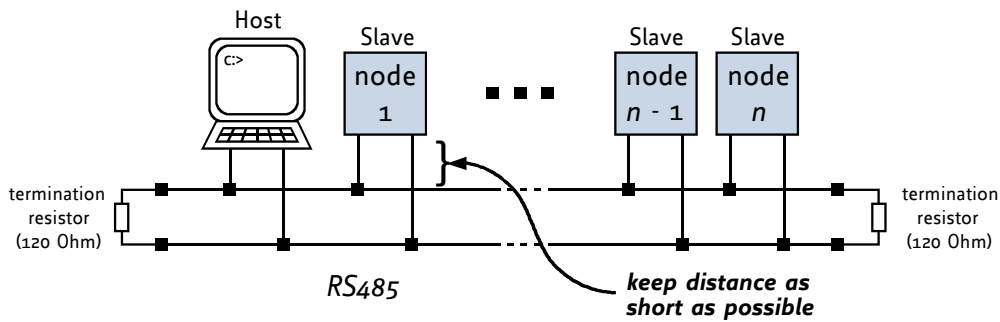

Figure 5.3: Bus structure

2. **BUS TERMINATION:**
Especially for longer busses and/or multiple nodes connected to the bus and/or high communication speeds, the bus should be properly terminated at both ends. The TMCM-3212 does not integrate any termination resistor. Therefore, 120 Ohm termination resistors at both ends of the bus have to be added externally.
3. **NUMBER OF NODES:**
The RS485 electrical interface standard (EIA-485) allows up to 32 nodes to be connected to a single bus. The bus transceivers used on the TMCM-3212 units (SN65HVD1781D) have a significantly reduced bus load and allow a maximum of 255 units to be connected to a single RS485 bus using TMCL firmware. *Please note: usually it cannot be expected to get reliable communication with the maximum number of nodes connected to one bus and maximum supported communication speed at the same time. Instead, a compromise has to be found between bus cable length, communication speed and number of nodes.*
4. **COMMUNICATION SPEED:**
The maximum RS485 communication speed supported by the TMCM-3212 hardware is 1Mbit/s. Factory default is 9600 bit/s. *Please see separate firmware manuals for information regarding other possible communication speeds below the upper limit in hardware.*
5. **NO FLOATING BUS LINES:**
Avoid floating bus lines while neither the host/master nor one of the slaves along the bus line is transmitting data (all bus nodes switched to receive mode). Floating bus lines may lead to communication errors. In order to ensure valid signals on the bus it is recommended to use a resistor network connecting both bus lines to well defined logic levels.

There are actually two options which can be recommended:
Add resistor (Bias) network on **one** side of the bus, only (120R termination resistor still at **both** ends):

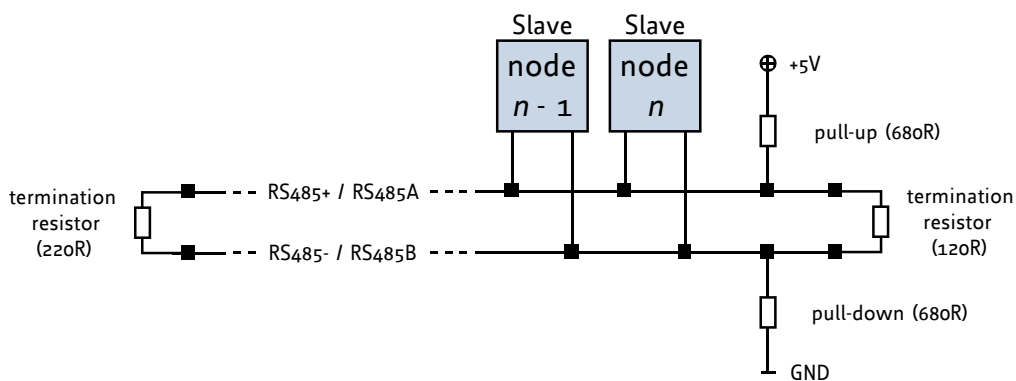

Figure 4.4: Bus lines with resistor (Bias) network on one side, only

Or add resistor (Bias) network at **both** ends of the bus (like Profibus™ termination):

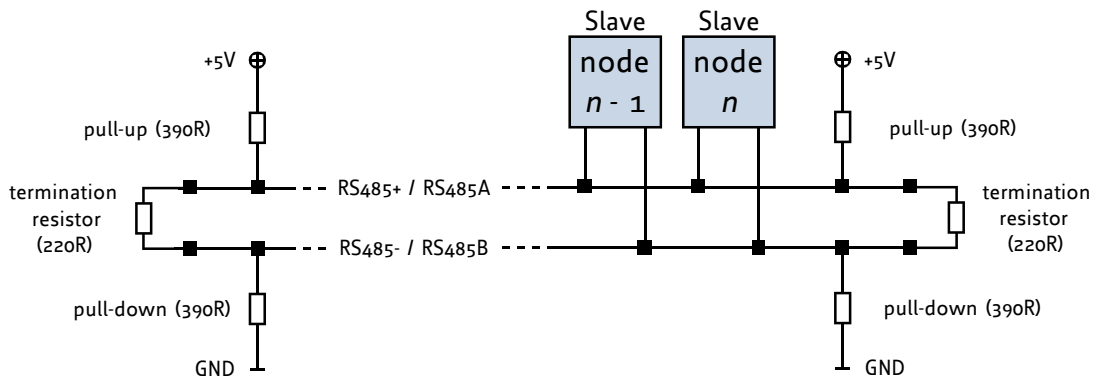

Figure 4.5: Bus lines with resistor (Bias) network at both ends

Certain RS485 interface converters available for PCs already include these additional resistors (e.g. USB-2-485 with bias network at one end of the bus).

5.7 CAN

For remote control and communication with a host system the TMCM-3212 provides a CAN bus interface. For proper operation the following items should be taken into account when setting up a CAN network:

1. **BUS STRUCTURE:**

The network topology should follow a bus structure as closely as possible. That is, the connection between each node and the bus itself should be as short as possible. Basically, it should be short compared to the length of the bus. The TMCM-3212 offers two connectors (RJ45) which are connected directly to each other and the on-board CAN transceiver. Using both connectors for passing through the bus will help with keeping a proper bus topology.

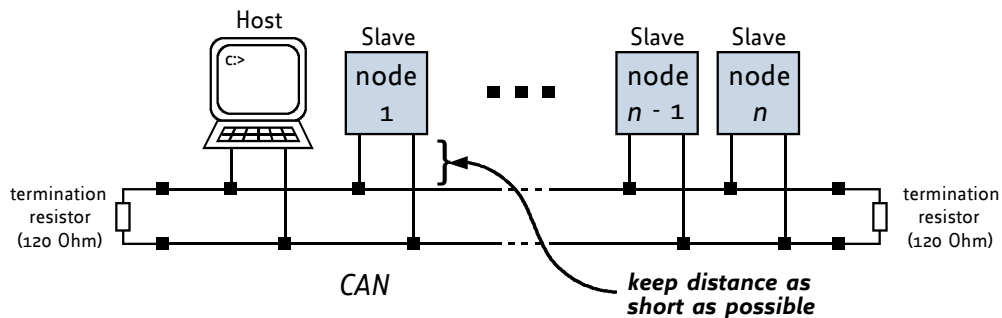

Figure 5.6: CAN bus structure

2. **BUS TERMINATION:**

Especially for longer busses and/or multiple nodes connected to the bus and/or high communication speeds, the bus should be properly terminated at both ends. The TMCM-3212 does not integrate any termination resistor. Therefore, 120 Ohm termination resistors at both ends of the bus have to be added externally.

5.7.1 CAN adapter

As part of the cable loom for the TMCM-3212 (G4-CABLE) an adapter pcb is available (RJ45-2-DSUB_G4_V10) for making CAN bus connection via standard D-SUB connectors instead of the RJ45 available on the TMCM-3212. A standard e.g. CAT5 ethernet cable might be used to connect the RJ45 connector on the TMCM-3212 with the RJ45 connector on the adapter pcb. The D-SUB connector on the adapter pcb might then be used to connect further slaves or the master with CAN D-SUB connectors. Please make sure to maintain a proper bus structure while using the adapter pcb.

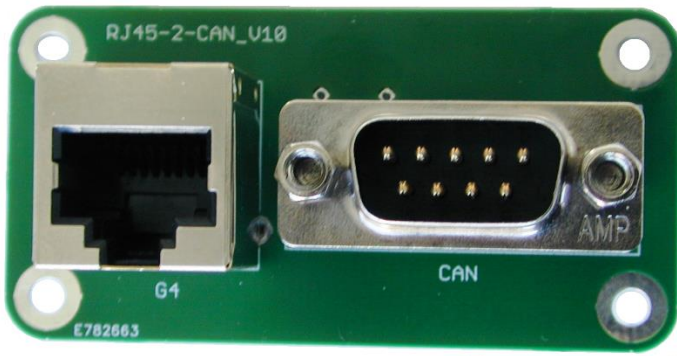

Figure 5.6: RJ45-2-DSUB PCB top view

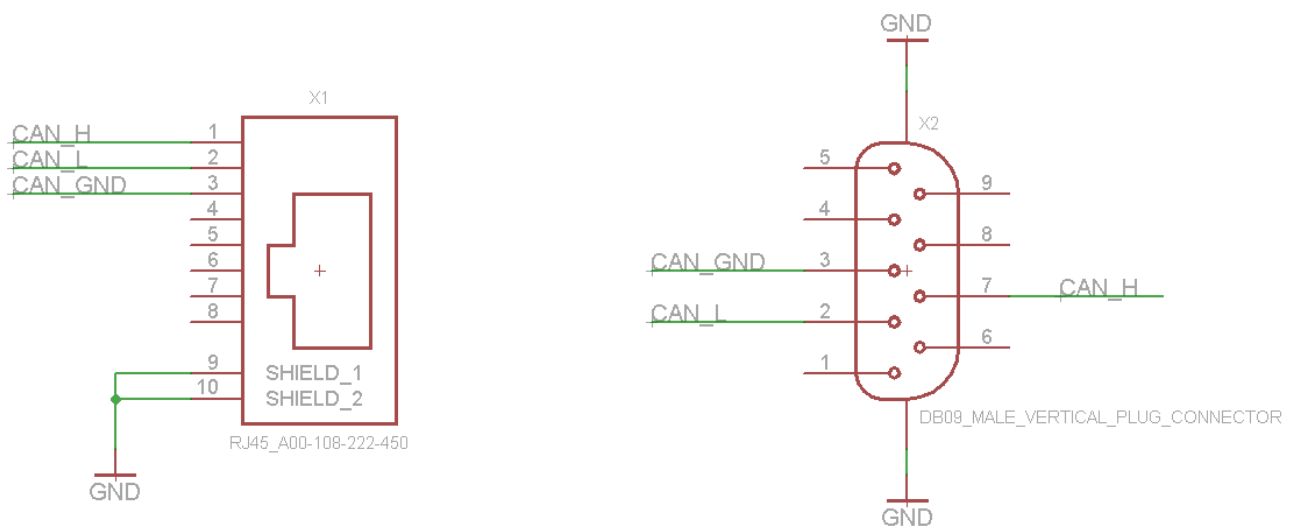

Figure 5.7: RJ45-2-DSUB schematic / connector pin assignment

5.8 General purpose outputs OUT_{0..3}

The TMC3212 and TMC3213 offer 4 open-drain (N-channel MOSFET) general purpose outputs available at the output connector of the interface brick part. The internal connection of the N-channel MOSFETs together with a flyback / freewheeling diode can be seen in figure 5.8. When activating the MOSFET the related output will be pulled low (sometimes called npn-style switch).

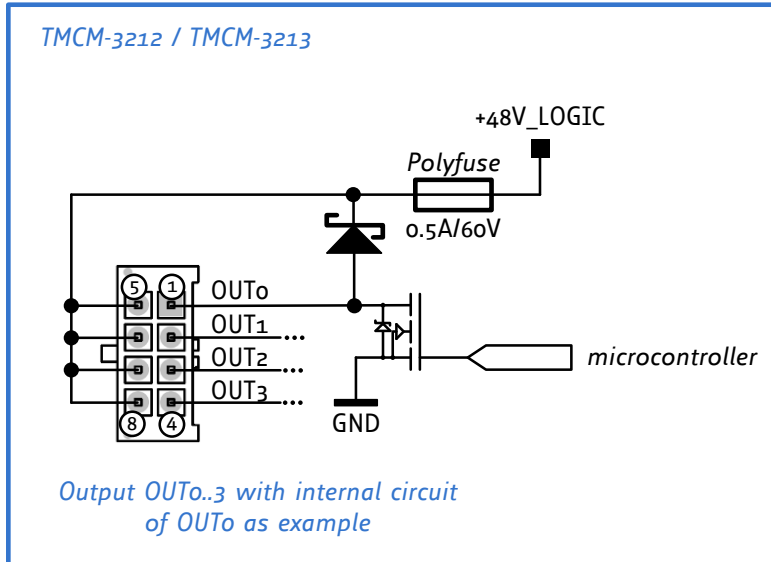

Figure 5.8: General purpose output – internal circuit (simplified)

6 Motor driver current

The stepper motor driver section of the TMCM-3212 + TMCM-3213 operates current controlled. The driver current may be programmed in software with 256 effective scaling steps in hardware up-to 3A RMS / 4.2A peak max. motor coil current.

Motor current measured for one phase with max. current settings (100% e.g. "SAP 179, 0, 0" and "SAP 6, 0, 255") and 256 microsteps:

CH1 (yellow): motor current [100mV / A]

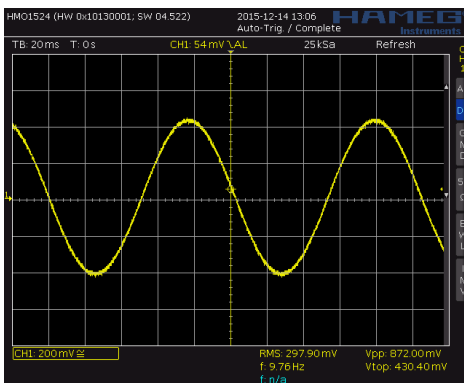

Motor current setting in software (TMC)

In TMCL axis parameter 6 (motor run current) and 7 (motor standby current) can be used for motor current setting:

```
SAP 6, 0, <value> // set run current
```

```
SAP 7, 0, <value> // set standby current
```

For <value> numbers between 0 (minimum) and 255 (maximum) are supported. Motor current is scaled linearly up-to 3A RMS / 4.2A peak.

(read-out value with GAP instead of SAP. Please see separate TMCM-3212 / TMCM-3213 firmware / software manual for further information)

Range setting in software (TMCL)

TMCL axis parameter 179 (Vsense) will set the current range:

```
SAP 179, 0, <value> // = 0 high current range
                    //   up-to 3A RMS/4.2A peak
                    // = 1 low current range
                    //   up-to 1.7A RMS / 2.4A peak
```

For <value> either 0 (high current range) or 1 (low current range) is supported. (read-out value with GAP instead of SAP.)

7 On Board LEDs

There are a number of LEDs on-board indicating status.

7.1 Power supply brick

With the TMCM-3212 and TMCM-3213 three LEDs are available on the power supply brick part.

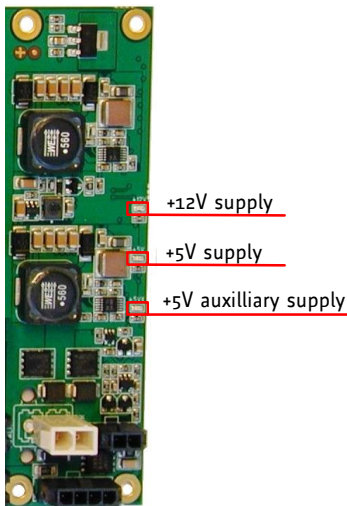

Figure 7.1: LEDs on power supply brick

LED	Description
+12V supply	+12V available from on-board DC/DC converter for supply of the pre-driver circuit
+5V supply	+5V available from on-board DC/DC converter for supply of on-board digital circuit
+5V auxiliary supply	+5V auxiliary supply available (can be switched on/off in software). +5V_OUT on REF/HOME and ENCODER connector.

7.2 TMCM-3212 Interface Brick

With the TMCM-3212 there are two LEDs (one green and one red) available. Both are connected to the on-board microcontroller and function is firmware dependent. With TMCL firmware the green LED is flashing slowly during operation. During firmware updates both LEDs are switched on.

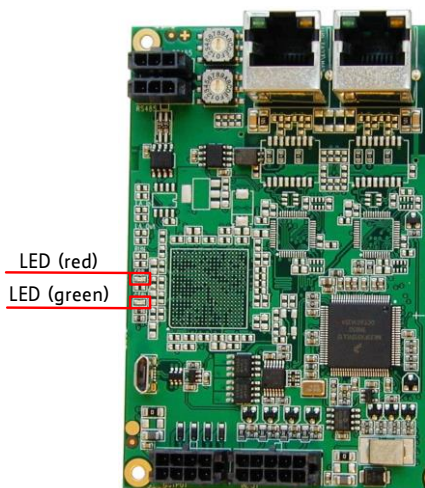

Figure 7.2: LEDs on TMCM-3212 interface brick

7.3 TMCM-3213 Interface Brick

With the TMCM-3213 there are five LEDs available. Two LEDs are connected to the processor and three to the EtherCAT™ slave controller (ESC). In addition, one LED (ERROR) is connected to both, the microcontroller and the ESC.

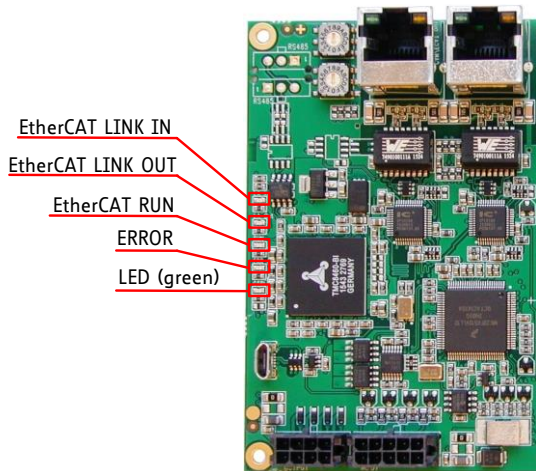

Figure 7.3: LEDs on TMCM-3213 interface brick

LED	Description
EtherCAT™ LINK IN	Signal LINK IN, connected to ESC
EtherCAT™ LINK OUT	Signal LINK OUT, connected to ESC
EtherCAT RUN	Indicating status of EtherCAT state machine, connected to ESC
ERROR	Connected to microcontroller and ESC – indicating Error
LED (green)	Connected to microcontroller – flashing slowly during normal operation

8 Reset to Factory Default

For reset to factory default values please follow instructions below:

1. Switch OFF power supply.
2. Short two pads of programming connector pad-array (see figure 8.1).
3. Switch ON power supply (on-board LED should be flashing fast / faster than during normal operation).
4. Switch OFF power supply.
5. Remove short circuit.

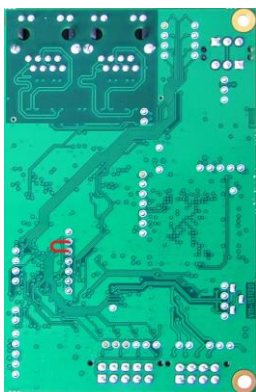

Figure 8.1 Reset to factory defaults (bottom view of pcb - interface brick end)

9 Operational ratings

The operational ratings show the intended or the characteristic ranges and should be used as design values.
In no case shall the maximum values be exceeded.

Symbol	Parameter	Min	Typ	Max	Unit
+48V	Power supply voltage input	10 17 ^{*)}	24..48	53	V
+48V_LOGIC	Power supply voltage for on-board digital / logic (if supplied separately)	Same as +48V supply input			V
I _{PEAK}	Motor coil current for sine wave peak (chopper regulated, adjustable via software)			4.2	A
I _{RMS}	Continuous motor current (RMS)			3	A
I _{+24V}	Power supply current for driver		<< 3 x I _{RMS}		A
T _{ENV}	Environmental temperature at 3x 3A RMS motor current (no forced cooling)	-30 ^{**)}		+50 ^{***)}	°C

Table 9.1: General operational ratings of the module

^{*)} On-board supply and processor running at 10V supply voltage input – motor driver stages are switched on and operational at around 17V supply voltage input (and switched off again at around 15V)

^{**)} limited by test equipment. Operation down to -40°C can be expected. Test included "cold" start at this temperature.

^{***)} Test set-up / procedure: module placed inside climate chamber (Binder MK53) with approx. 53l volume. Motor placed outside chamber moving slowly with motor current set to maximum supported by module (3x 3A RMS). Test duration: 24h. Communication tested at beginning and end of test.

Symbol	Parameter	Min	Typ	Max	Unit
V _{REFL/R_HOME}	Input voltage for stop / home switch inputs REFL / REFR and HOME	0		5.5	V
V _{REFL/R_HOME_L}	Low level voltage for stop / home switch inputs REFL / REFR and HOME	0		1.1	V
V _{REFL/R_HOME_H}	High level voltage for stop / home switch inputs REFL / REFR and HOME	3.3			V
V _{OUT0..3}	Voltage at open collector output OUT0...OUT3	0		Same as +48V supply input	V
I _{OUT0..3}	Output sink current for OUT0...OUT3			1	A
V _{AIN0..3}	Full scale input voltage range for analog inputs AIN0...AIN3	0		10 ^{*)}	V

Table 9.2 Operational ratings of I/Os

^{*)} nominal upper input voltage which can be measured without saturation of the ADC. Max. voltage at max. ADC value will be around 10.56V.

10 TMCM-3212 Functional Description

The TMCM-3212 is a highly integrated controller/driver module for 3 stepper motor axes which can be controlled via several serial interfaces (CAN, RS485 and USB – depending on firmware). Communication traffic is kept low since all time critical operations (e.g. ramp calculations) are performed on board. The nominal supply voltage of the unit is 24V or 48V DC. The module is designed for both, standalone operation and direct mode. Full remote control of device with feedback is possible. The firmware of the module can be updated via one of the serial interfaces (depending on module and firmware type).

In Figure 10.1 the main parts of the TMCM-3212 are shown:

- Microcontroller, responsible for overall control - executes the firmware (either TMCL or CANopen incl. the communication stack)
- 3 motion controller and pre-driver with additional higher-power MOSFETs. With the integrated motion controller calculation of ramps (linear and sixPoint™) and speed profiles is done internally in hardware.
- interface for an external (e.g. optical) incremental A/B/N encoder (differential RS422 signals) for each axis. The encoder may be used for position verification and step-loss detection. For closed-loop operation please consider using the TMCM-3312 unit.
- interface for HOME / REFL / REFR reference switches for each axis
- 4 general purpose analog / digital inputs
- 4 general purpose digital (open-drain) outputs
- Three serial communication interfaces: CAN, RS485 and USB (Micro-USB-connector). While CAN and RS485 are intended for in-system control and operation (for CANopen firmware just CAN) the USB interface may be primarily used for parameter settings and firmware updates.

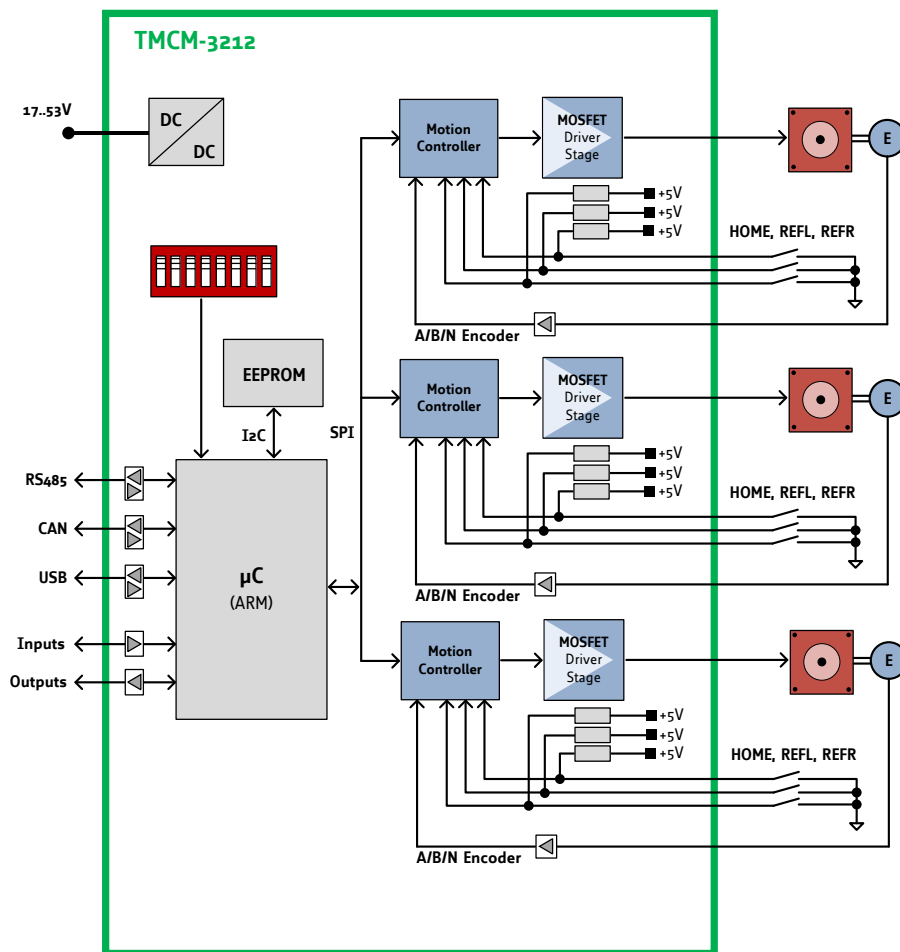

Figure 10.1 Main parts of the TMCM-3212

11 TMCM-3213 Functional Description

The TMCM-3213 is a highly integrated controller/driver module for 6 stepper motor axes which offers an EtherCAT™ interface in addition to USB for communication. The nominal supply voltage of the unit is 24V or 48V DC. Full remote control of the device with feedback is possible using the CANopen over EtherCAT™ (CoE) firmware. The firmware of the module can be updated via one of the serial interfaces.

In Figure 10.1 the main parts of the TMCM-3213 are shown:

- Microcontroller, responsible for overall control - executes the firmware (CANopen over EtherCAT, CoE)
- 3 motion controller and pre-driver with additional higher-power MOSFETs. With the integrated motion controller calculation of ramps (linear and sixPoint™) and speed profiles is done internally in hardware.
- interface for an external (e.g. optical) incremental A/B/N encoder (differential RS422 signals) for each axis. The encoder may be used for position verification and step-loss detection. For closed-loop operation please consider using the TMCM-3313 unit.
- interface for HOME / REFL / REFR reference switches for each axis (either encoder interface or reference switches can be selected in software)
- 4 general purpose analog / digital inputs
- 4 general purpose digital (open-drain) outputs
- EtherCAT™ and USB interfaces for communication. The EtherCAT™ interface is intended for in-system control and operation (using CoE firmware), while USB may be used for parameter setting and firmware updates

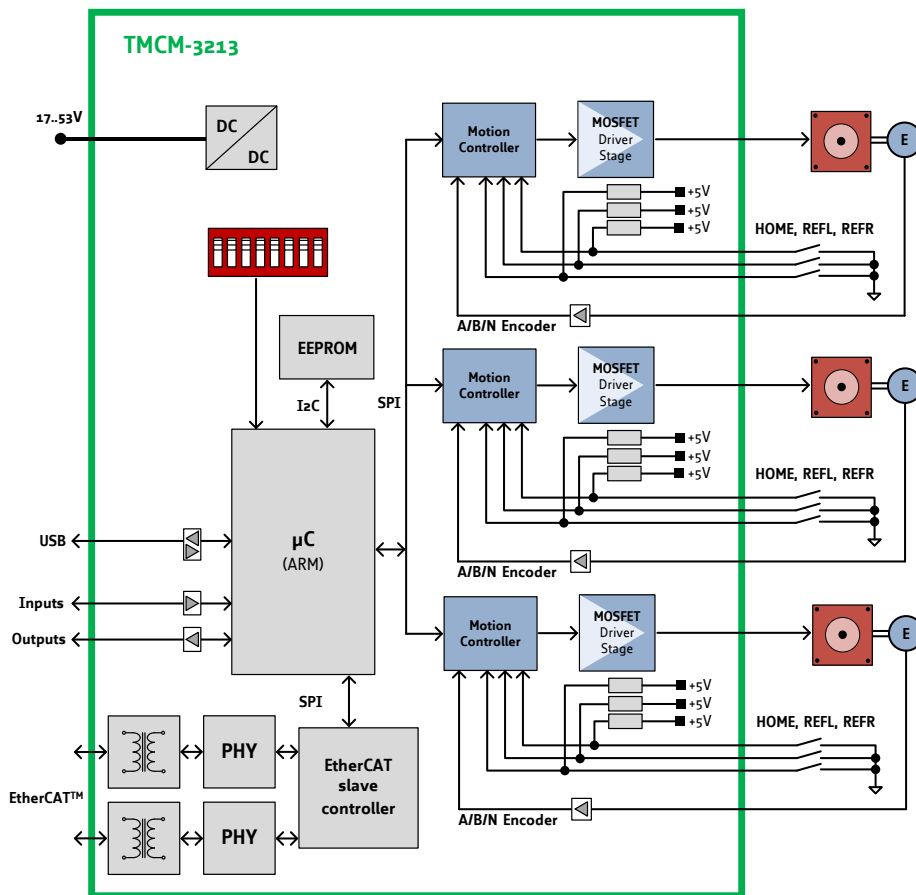

Figure 11.1 Main parts of the TMCM-3213

12 Revision History

12.1 Document revision

Version	Date	Author	Description
0.90	2016-MAR-16	GE	Initial version based on TMC-6210 / TMC-6211 Vo.93 hardware manual
0.91	2016-MAR-29	GE	Several corrections
0.92	2016-APR-19	GE	Supply output on Output and Input connectors corrected (+48V_FUSE)
0.93	2016-APR-21	GE	Operational ratings adapted to release firmware version V1.03
0.94	2016-MAY-18	GE	Power supply brick, Control Connector pin assignment in figure 5.5 corrected
0.95	2017-MAR-01	GE	<ul style="list-style-type: none"> Block diagram and functional description simplified / clarified General purpose outputs description added

Table 12.1: Document revision

12.2 Hardware revision

Version	Date	Description
TMC-3213_V09	2015-FEB-23	Initial version
TMC-3213_V10	2015-JUL-29	<ul style="list-style-type: none"> HOME and REFL connection exchanged (corrected)
TMC-3213_V11	2015-NOV-04	<ul style="list-style-type: none"> Complete re-layout of driver brick in order to minimize crosstalk / noise
TMC-3212_V10	2015-JUL-29	Based on TMC-3213_V10
TMC-3212_V11	2015-NOV-04	Based on TMC-3213_V11

Table 12.2: Hardware revision

13 References

[MOLEX]	MOLEX connector http://www.molex.com
[TMCL-IDE]	TMCL-IDE User Manual Manual available on http://www.trinamic.com .

X-ON Electronics

Largest Supplier of Electrical and Electronic Components

Click to view similar products for [Motor Drives](#) category:

Click to view products by [Analog Devices](#) manufacturer:

Other Similar products are found below :

[GMA02](#) [R7DBP02L](#) [1300920283](#) [ST10-S](#) [GMA11](#) [GMA20](#) [R88DUA03LAAC100V30W](#) [R88DUA12HA](#) [R88DUP03LAAC100V30W](#)
[STR2](#) [VFD002EL11A](#) [MFMCB0030GET](#) [MFECA0030EAM](#) [1302263150](#) [1300920078](#) [R88D-GN04H-ML2](#) [R88D-KT01H](#) [R7D-BP01H](#)
[R88D-KN04L-ECT](#) [70354063](#) [79294435](#) [27358015](#) [15275008](#) [ST5-Q-EN](#) [1SFA896103R1100](#) [1SFA896103R7000](#) [1SFA896112R1100](#)
[R88D-GP08H](#) [GNCF8-11](#) [KLC35BE](#) [ST10-Q-RN](#) [1302263161](#) [SV2D10-Q-AE](#) [VX5A1300](#) [R88A-CA1C005SF-E](#) [R88A-CR1B005NF-E](#)
[SEH 71-4B](#) [U-PKZ0\(400V50HZ\)](#) [LUCC12BL](#) [LUCC12FU](#) [LU9BN11L](#) [LULC08](#) [GV2P01](#) [UDS1UR6M50CANCZ183](#) [LC1D09M7](#)
[103H7126-1740](#) [103H7823-1741](#) [111.3761.20.00E](#) [111.3761.30.00E](#) [808070RAT250](#)