



Anaren Integrated Radio (AIR)

Low-power RF modules, firmware & development tools that make it easy to 'go wireless'

2530 System on Chip Series

The A2530E24AZ1 is a high-performance, FCC & IC certified and ETSI-compliant radio module that incorporates the Texas Instruments CC2530 SOC with a CC2591 Range Extender, and integral antenna, all in one of the industry's smallest packages: 11 x 19 x 2.5 mm. The module comes pre-loaded with Anaren's AIR-ZNP for ZigBee®* Standard firmware.



A2530E24AZ1

Features

General:

- 2.4-GHz IEEE 802.15.4 compliant RF transceiver
- Excellent receiver sensitivity and robustness to interference (-95dBm average)
- Wide input voltage range (2.2V – 3.6V)
- Module weight approximately 0.7 grams

Current Consumption: (Typ @ 25°C, VDD = 3.0V)

- Active mode RX (CPU Idle): 28 mA
- Active mode TX (CPU Idle): 67 mA @1dBm, 77mA @8dBm (limit for ETSI compliance), 128mA @ 15dBm (limit for FCC/IC compliance)
- 3 Low power/sleep modes from 0.4uA to 225uA

Microcontroller:

- High-performance and low-power 8051 Microcontroller core with code prefetch
- 256KB in-system programmable flash and 8KB RAM with retention in all power modes

Firmware:

- Preloaded with Anaren's AIR-ZNP firmware, based on the TI Z-Stack™ for the ZigBee® Standard
- Supports SPI and UART communication
- Driver library included for MSP430™ and Tiva™ C MCUs, which abstracts functionality
- Over 30 code examples for a paired MCU included to demonstrate functionality, including:

- Button Blink: Blinks LED when button pressed
 - Hello World: Outputs 'Hello World' to the PC via USB
 - Get Module Version: Displays module version
 - Get MAC Address: Displays internal MAC address
 - Write NV Items: Writes to user-accessible non-volatile memory
 - Read NV Items: Reads user-accessible non-volatile memory
 - Read Radio GPIO: Displays value of module GPIO 1-4
 - Write Radio GPIO: Writes values to module GPIO 1-4
 - Coordinator Function: AF/ZDO, Simple API, or Secure
 - Router Function: AF/ZDO, Simple API, or Secure
 - End Point Function: AF/ZDO
 - RF Tester: RF test utility
- AND MANY MORE!**

Benefits

- Minimal RF engineering experience necessary
- Minimal ZigBee® experience necessary
- Easy to program and implement, short design cycle
- No additional "Intentional Radiator" certification required (FCC 15.247, IC RSS-210, EN 300 328)
FCC ID: X7J-A11091301 // IC: 8975A-A11091301
- Suitable for export (ECCN 5A002.a.1 per CCATS G147235) and is eligible for license exception under sections 740.17(A) and (B)(3) of the EAR
- Minimal real estate required
- Easily implemented on a two layer PCB
- No additional harmonic filtering required
- 100% RF-tested in production
- Common footprint for similar products in family
- No additional DC decoupling required
- Includes IEEE 802.15.4 MAC Timer
- CSMA/CA hardware support
- Accurate Digital RSSI/LQI support
- Battery monitor and temperature sensor
- AES Security co processor
- Operating temperature -40 to +85°C

Applications

ZigBee® Light Link control systems, ZigBee® systems, Home/building automation, lighting systems, low power wireless sensor networks, consumer electronics, industrial control and monitoring.

PLEASE NOTE: Additional information on the Texas Instruments CC2530 and CC2591 devices can be found in the company's latest datasheet release at <http://www.ti.com>



This product is not to be used in any implantable medical device or external medical device intended to regulate or monitor biological functions, including but not limited to devices such as pacemakers, defibrillators, cardiac resynchronization devices, pressure sensors, biochemical stimulators and neurostimulators. ANAREN MAKES NO WARRANTY OF FITNESS OR MERCHANTABILITY OF THIS PRODUCT FOR ANY USE OF THIS TYPE. Anaren shall not be responsible for any consequential damages arising from the sale or use of this product for any use of this type. The ultimate user of the product assumes all risk of personal injury or death arising from a prohibited use.



For more information see product User's Manual, available online.



Anaren, Inc. | 6635 Kirkville Road | East Syracuse, NY 13057
800.411.6596 | www.anaren.com/air | AIR@anaren.com

* The terms ZigBee®, ZigBee® Alliance, and ZigBee® Standard are registered trademarks of ZigBee®



Anaren Integrated Radio (AIR)

Low-power RF modules, firmware & development tools that make it easy to 'go wireless'

Product overview

The A2530E24AZ1 is a high-performance, FCC & IC certified and ETSI-compliant ZigBee®/IEEE 802.15.4 RF SOC module that incorporates the Texas Instruments CC2530 transceiver chip and CC2591 range extender in the industry's smallest package (11 x 19 x 2.5 mm). The module incorporates a crystal, the required RF matching and filtering for regulatory compliance, plus filtering on select digital lines for better noise reduction and sensitivity. The modules operate in the global unlicensed 2.4GHz ISM/SRD frequency band. These radio modules are ideal for achieving low power wireless connectivity without having to deal with extensive Protocol, RF design and regulatory compliance, allowing quick time to market. The modules are 100% tested to provide consistent performance.

The A2530E24AZ1 has an RoHS-compliant ENIG finish and is packaged in 27-piece matrix trays or on 500-piece tape & reel for high-volume automated manufacturing.

Pin diagram

Pin-out shown is for operation using the AIR-ZNP for ZigBee® Standard firmware; native pin functionality is also shown. See TI CC2530 / CC2591 data sheets and A2530 User's Manual for detailed pin descriptions.

Viewed from top side

Where applicable:

NC = "No Connection"
Pin is NOT connected internally

DNC = "Do Not Connect" Pin reserved for internal use; ensure mating footprint pads are isolated.

GND = "Ground"
Connect the maximum number possible (minimum one for proper operation).

References in (parentheses) show native CC2530 pin function.

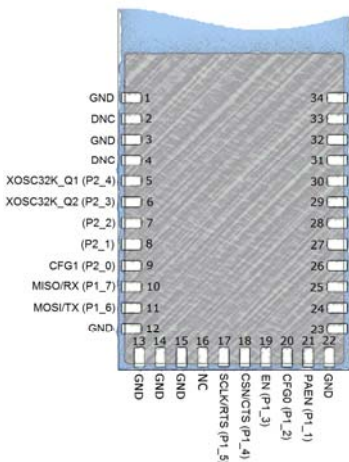

Block diagram

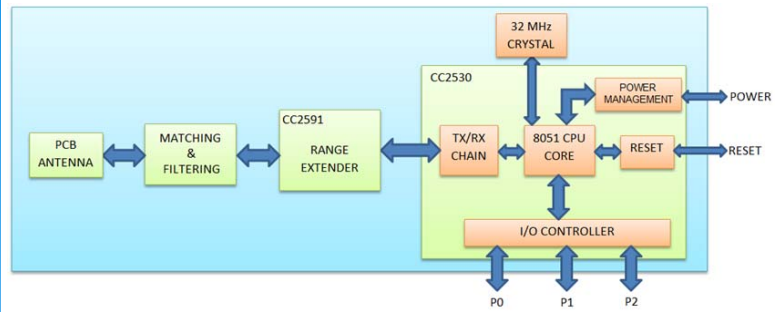

Layout information

See product User's Manual for detailed information.

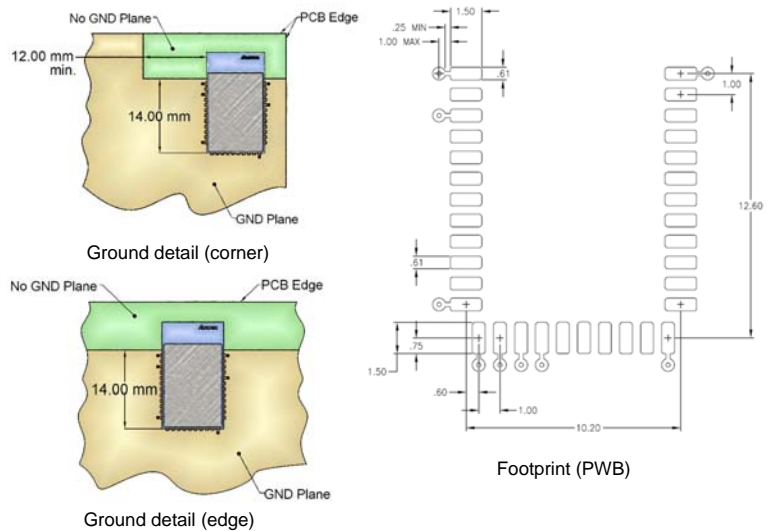

Nomenclature

A2530E24AZ1GR

1 2 3 4 5 6 7

- A (Anaren)
- 1 Chip series (CC1101, CC2500, CC2530, CC8520)
- 2 Function (R = radio only, E = Range Extender)
- 3 Frequency band (x 100MHz)
- 4 Form factor (A = Internal Antenna, C = Connector)
- 5 Design ID (Z1 = Loaded with Anaren AIR-ZNP for ZigBee® Standard)
- 6 Application (G = General)
- 7 Packaging (R = Reel, M = Matrix Tray)



Caution! ESD sensitive device. Precautions should be used when handling the device in order to prevent permanent damage.



The item described in this product brief is part of our total AIR Support solution. To learn more, visit our website or just ask us!

For more information see product User's Manual, available online.



X-ON Electronics

Largest Supplier of Electrical and Electronic Components

Click to view similar products for [Zigbee Modules - 802.15.4 category](#):

Click to view products by [Anaren manufacturer](#):

Other Similar products are found below :

[XBP24-ASI-080](#) [ATZB-RF-212B-0-CNR](#) [34560-894](#) [32411](#) [32416](#) [32406](#) [E18-MS1PA2-PCB](#) [ZTU\(ujzh\)](#) [BB-WCD1H2102H](#) [BB-WCD1H3001HP100](#) [BB-WSD2C31010](#) [BB-WSD2M31010](#) [BB-WSK-SLM-2](#) [BB-WSD2C21150](#) [BB-WSK-CBM-2](#) [20848674](#) [BB-WSD2M3101P2K](#) [WSD2M06010](#) [BB-WCD1H2102H](#) [BB-WSD2C21150](#) [BB-WSD2M31010](#) [WSD2CTJ](#) [WSD2MD2](#) [WPMM1A01A](#) [WPMM1A02A](#) [WPMM1A05A](#) [ATZB-RF-233-1-CR](#) [ATSAMR21G18-MR210UA](#) [ATSAMR21G18-MR210UAT](#) [MRF24J40MA-I/RM](#) [AX-SF10-ANT21-868-B1](#) [AX-SF10-MINI21-868-B1](#) [24572054](#) [114990002](#) [EM357-MOD-ANT-T](#) [ETRX3587HR-LRS](#) [WPMM1A00A](#) [ATZB-RF-212B-0-CN](#) [WMPR1A00B1A2](#) [WMPR1A02B1A2](#) [WMPR1A00B1A1](#) [WMPR1A02B1A1](#) [WPMM1A04A](#) [WPMM1A01B](#) [WPMM1A02AS01](#) [WMPR1A02A1A1](#) [CGW-Z-0010-01-00](#) [XB24CAPIS-001](#) [XB24CAPIT-001](#) [XB24CAUIT-001](#)