

Features

- High collector-emitter breakdown voltage.
($V_{CE0} = 40V @ I_C = 10mA$)
- Small load switch transistor with high gain and low saturation voltage, is designed for general purpose amplifier and switching applications at collector current.
- Capable of 225mW power dissipation.
- Lead-free parts for green partner, exceeds environmental standards of MIL-STD-19500 /228
- Suffix "-H" indicates Halogen-free part, ex.MMBT2222-H.

Mechanical data

- Epoxy: UL94-V0 rated flame retardant
- Case : Molded plastic, SOT-23
- Terminals : Solder plated, solderable per MIL-STD-750, Method 2026
- Mounting Position : Any

Package outline

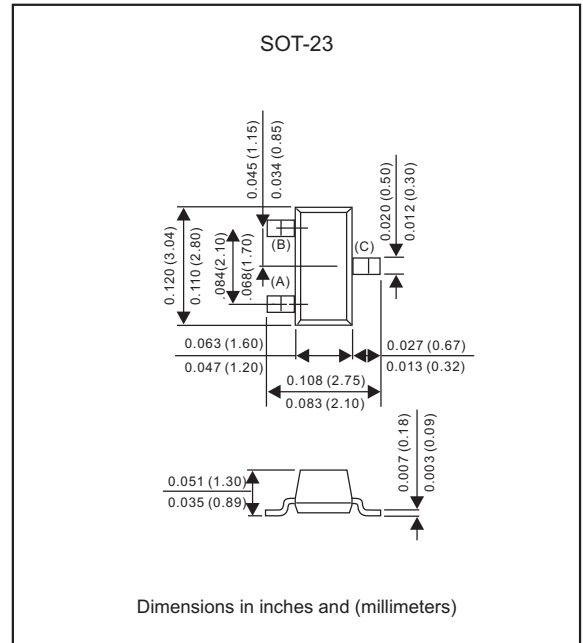

Maximum ratings (AT $T_A = 25^\circ C$ unless otherwise noted)

PARAMETER	CONDITIONS	Symbol	MMBT2222	MMBT2222A	UNIT
Collector-base voltage		V_{CBO}	60	75	V
Collector-emitter voltage		V_{CEO}	30	40	V
Emitter-base voltage		V_{EBO}	5.0	6.0	V
Collector current		I_C	600		mA
Total device dissipation FR-5 board (1)	$T_A = 25^\circ C$	P_D	225		mW
	Derate above $25^\circ C$		1.8		mW/ $^\circ C$
Thermal resistance(1)	Junction to ambient	$R_{\theta JA}$	556		$^\circ C/W$
Total device dissipation alumina substrate(2)	$T_A = 25^\circ C$	P_D	300		mW
	Derate above $25^\circ C$		2.4		mW/ $^\circ C$
Thermal resistance(2)	Junction to ambient	$R_{\theta JA}$	417		$^\circ C/W$
Operating junction temperature range		T_J	-55 to +150		$^\circ C$
Storage temperature range		T_{STG}	-55 to +150		$^\circ C$

1.FR-5 = 1.0 X 0.75 X 0.062 in.

2.Alumina = 0.4 X 0.3 X 0.024 in. 99.5% alumina.

ELECTRICAL CHARACTERISTICS (TA = 25°C unless otherwise noted)

Characteristics		Symbol	Min	Max	Unit
OFF CHARACTERISTICS					
Collector-Emitter Breakdown Voltage (IC=10 mAdc, IB=0)	MMBT2222 MMBT2222A	V(BR)CEO	30 40	- -	Vdc
Collector-Base Breakdown Voltage (IC=10 µAdc, IE=0)	MMBT2222 MMBT2222A	V(BR)CBO	60 75	- -	Vdc
Emitter-Base Breakdown Voltage (IE=10 µAdc, IC=0)	MMBT2222 MMBT2222A	V(BR)EBO	5.0 6.0	- -	Vdc
Collector Cutoff Current (VCE=60 Vdc, VEB (off)=3.0 Vdc)	MMBT2222A	ICEX	-	10	nAdc
Collector Cutoff Current (VCB=50 Vdc, IE=0)	MMBT2222	ICBO	-	0.01	µAdc
(VCB=60Vdc, IE=0)	MMBT2222A		-	0.01	
(VCB=50Vdc, IE=0, TA=125 °C)	MMBT2222		-	10	
(VCB=60Vdc, IE=0, TA=125 °C)	MMBT2222A		-	10	
Emitter Cutoff Current (VEB=3.0 Vdc, IC=0)	MMBT2222A	IEBO	-	100	nAdc
Base Cutoff Current (VCE=60Vdc, VEB(off)=3.0Vdc)	MMBT2222A	IBL	-	20	nAdc

ELECTRICAL CHARACTERISTICS (TA = 25°C unless otherwise noted) (Continued)

Characteristics		Symbol	Min	Max	Unit
ON CHARACTERISTICS					
DC Current Gain		hFE			
(IC=0.1 mAdc, VCE=10 Vdc)			35	-	
(IC=1.0 mAdc, VCE=10 Vdc)			50	-	
(IC=10 mAdc, VCE=10 Vdc)			75	-	
(IC=10 mAdc, VCE=10 Vdc, TA=-55°C)	MMBT2222A ONLY		35	-	
(IC=150 mAdc, VCE=10 Vdc) (3)			100	300	
(IC=150 mAdc, VCE=1.0Vdc) (3)			50	-	
(IC=500 mAdc, VCE=10 Vdc) (3)	MMBT2222 MMBT2222A	30 40	- -		
Collector-Emitter Saturation Voltage (3)	MMBT2222 MMBT2222A	VCE(sat)	-	0.4	Vdc
(IC=150 mAdc, IB=15mAdc)	MMBT2222A		-	0.3	
(IC=500 mAdc, IB=50mAdc)	MMBT2222		-	1.6	
	MMBT2222A		-	1.0	
Base-Emitter Saturation Voltage (3)	MMBT2222 MMBT2222A	VBE(sat)	-	1.3	Vdc
(IC=150 mAdc, IB=15mAdc)	MMBT2222A		0.6	1.2	
(IC=500 mAdc, IB=50mAdc)	MMBT2222		-	2.6	
	MMBT2222A		-	2.0	

ELECTRICAL CHARACTERISTICS (T_A = 25°C unless otherwise noted) (Continued)

Characteristics	Symbol	Min	Max	Unit
SMALL-SIGNAL CHARACTERISTICS				
Current-Gain-Bandwidth Product (4) (I _C =20 mA, V _{CE} =20 Vdc, f=100MHz)	f _T	250 300	- -	MHz
Output Capacitance (V _{CB} =10 Vdc, I _E =0, f=1.0MHz)	C _{obo}	-	8.0	pF
Input Capacitance (V _{EB} =0.5 Vdc, I _C =0, f=1.0MHz)	C _{ibo}	- -	30 25	pF
Input Impedance (I _C =1.0 mA, V _{CE} =10 Vdc, f=1.0 kHz) (I _C =10 mA, V _{CE} =10 Vdc, f=1.0 kHz)	h _{ie}	2.0 0.25	8.0 1.25	κΩ
Voltage Feedback Ratio (I _C =1.0 mA, V _{CE} =10 Vdc, f=1.0 kHz) (I _C =10 mA, V _{CE} =10 Vdc, f=1.0 kHz)	h _{re}	- -	8.0 4.0	x 10 ⁻⁴
Small-Signal Current Gain (I _C =1.0 mA, V _{CE} =10Vdc, f=1.0 kHz) (I _C =10 mA, V _{CE} =10Vdc, f=1.0 kHz)	h _{fe}	50 75	300 375	-
Output Admittance (I _C =1.0 mA, V _{CE} =10Vdc, f=-1.0kHz) (I _C =10 mA, V _{CE} =10Vdc, f=-1.0kHz)	h _{oe}	5.0 25	35 200	μhos
Collector Base Time Constant (I _E =20 mA, V _{CB} =20 Vdc, f=31.8 MHz)	r _b , C _C	-	150	ps
Noise Figure (I _C =100μA, V _{CE} =10Vdc, R _S =1.0kΩ, f=1.0 kHz)	NF	-	4.0	dB

SWITCHING CHARACTERISTICS (MMBT2222A only)

Delay Time	(V _{CC} =30 Vdc, V _{BE} (off)=-0.5Vdc, I _C =150 mA, I _{B1} =15 mA)	t _d	-	10	ns
Rise Time		t _r	-	25	
Storage Time	(V _{CC} =30 Vdc, I _C =150 mA, I _{B1} =I _{B2} =15 mA)	t _s	-	225	ns
Fall Time		t _f	-	60	

3. Pulse Test: Pulse Width 300 μs, Duty Cycle ≤ 2.0%.

4. f_T is defined as the frequency at which h_{fe} extrapolates to unity.

Rating and characteristic curves (MMBT2222 / MMBT2222A)

Typical Pulsed Current Gain vs Collector Current

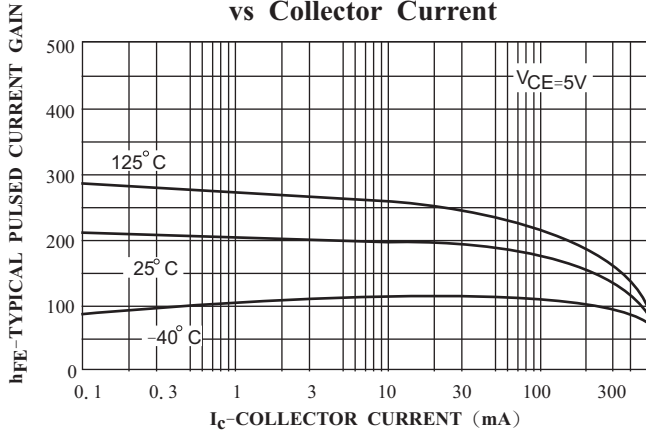

Collector- Emitter Saturation Voltage vs Collector Current

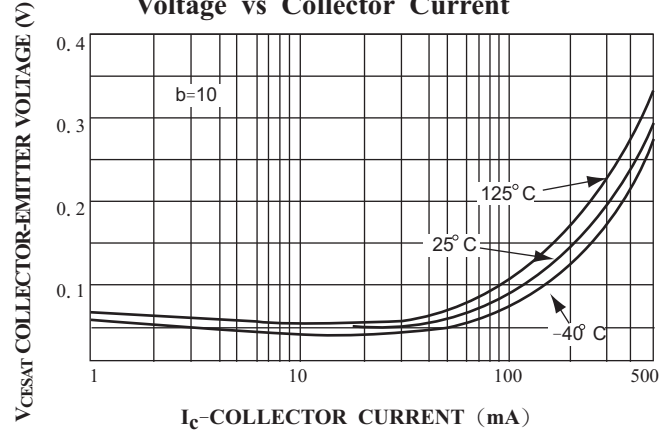

Base-Emitter Saturation Voltage vs Collector Current

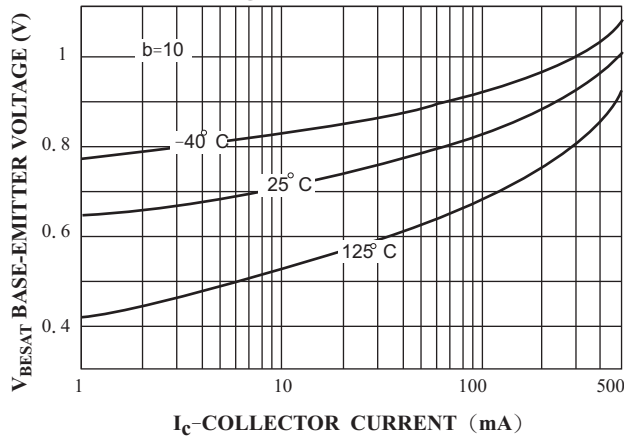

Base-Emitter ON Voltage vs Collector Current

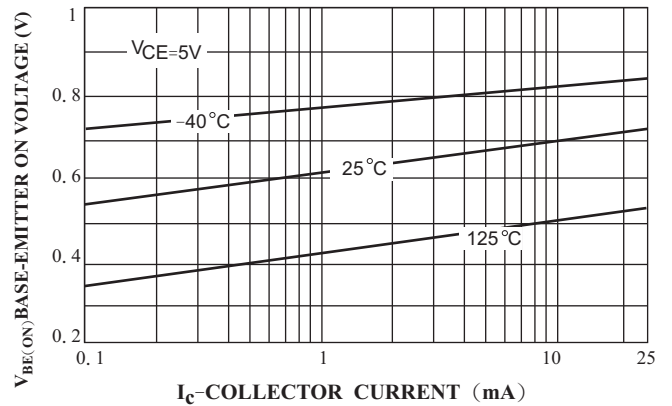

Collector-Cutoff Current vs Ambient Temperature

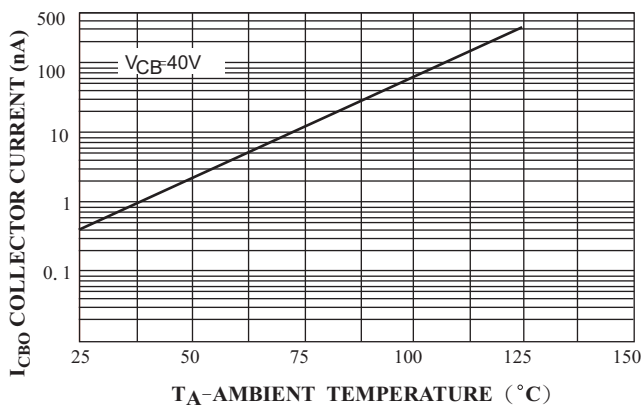

Emitter Transition and Output Capacitance vs Reverse Bias Voltage

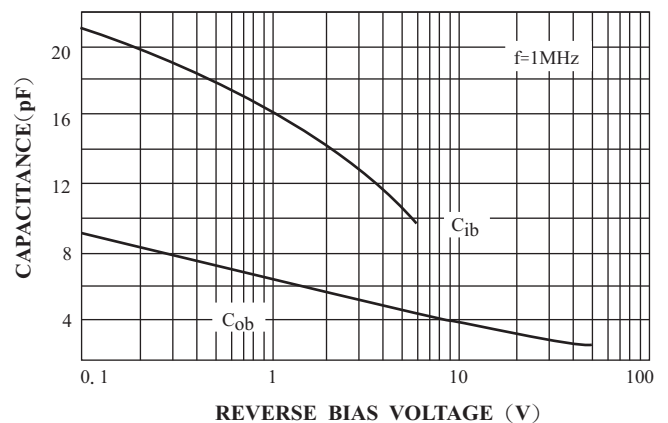

Rating and characteristic curves (MMBT2222 / MMBT2222A)

Turn On and Turn Off Times vs Collector Current

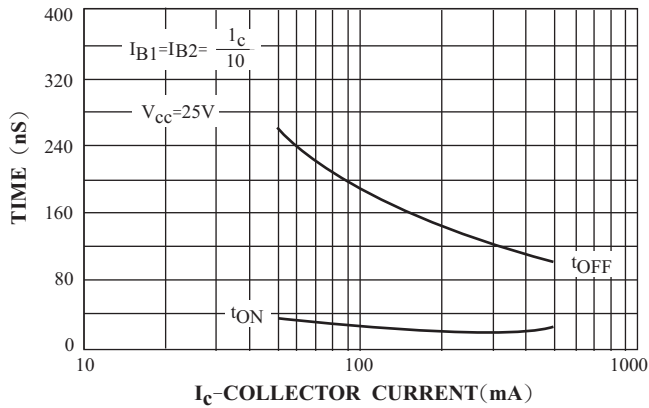

Switching Times vs Collector Current

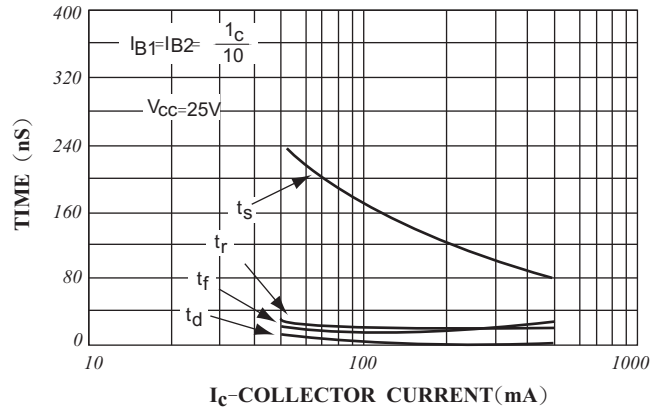

Power Dissipation vs Ambient Temperature

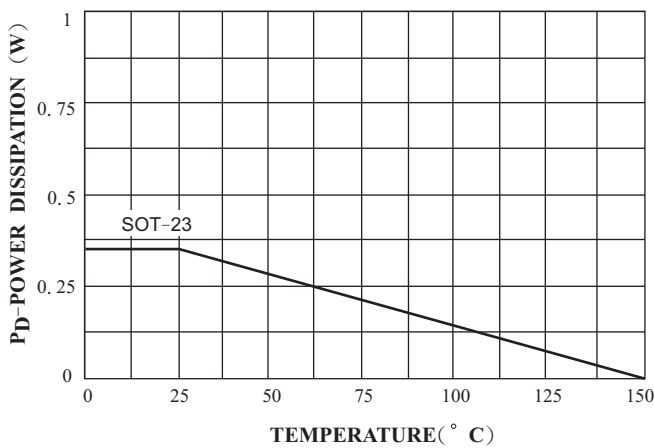

TEST CIRCUIT

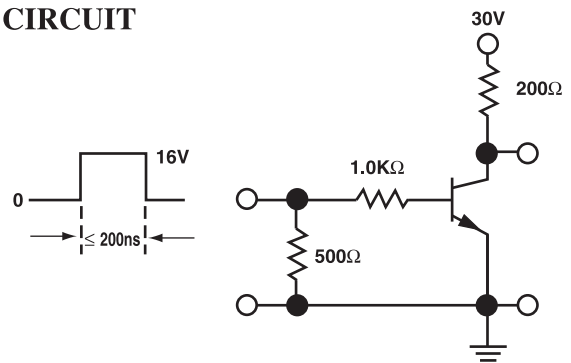

FIGURT 1: Saturated Turn-On Switching Time

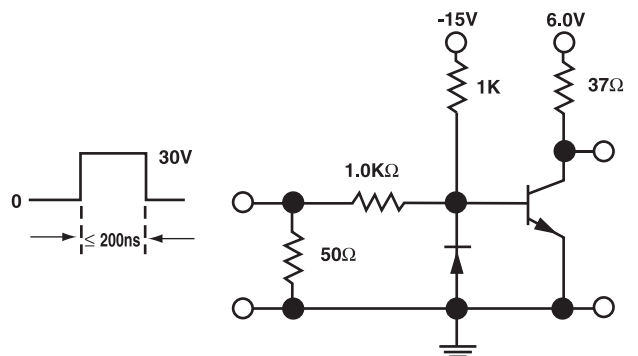

FIGURT 2: Saturated Turn-Off Switching Time

Pinning information

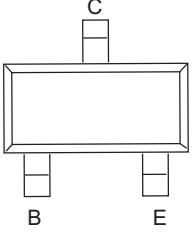
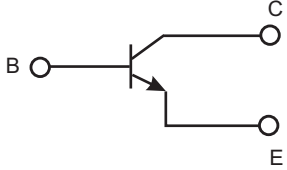
Pin	Simplified outline	Symbol
PinB Base PinC Collector PinE Emitter		

Marking

Type number	Marking code
MMBT2222	M1B
MMBT2222A	1P

Suggested solder pad layout

SOT-23

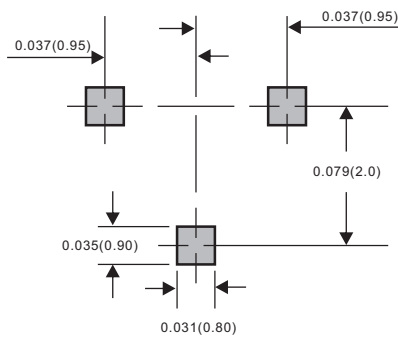

Dimensions in inches and (millimeters)

X-ON Electronics

Largest Supplier of Electrical and Electronic Components

Click to view similar products for [Bipolar Transistors - BJT category](#):

Click to view products by [AnBon manufacturer](#):

Other Similar products are found below :

[BC559C](#) [MCH4017-TL-H](#) [MMBT-2369-TR](#) [BC546/116](#) [NJVMJD148T4G](#) [NTE16](#) [NTE195A](#) [IMX9T110](#) [2N4401-A](#) [2N4403](#) [2N6728](#)
[2SA1419T-TD-H](#) [2SA2126-E](#) [2SB1204S-TL-E](#) [FMC5AT148](#) [2N2369ADCSM](#) [2N2907A](#) [2N3904-NS](#) [2N5769](#) [2SC4618TLN](#) [CPH6501-](#)
[TL-E](#) [MCH4021-TL-E](#) [Jantx2N5416](#) [US6T6TR](#) [BAX18/A52R](#) [BC556/112](#) [IMZ2AT108](#) [MMST8098T146](#) [UMX21NTR](#) [MCH6102-TL-E](#)
[TTA1452B,S4X\(S](#) [2N3879](#) [NTE13](#) [NTE282](#) [NTE323](#) [NTE350](#) [NTE81](#) [JANTX2N2920L](#) [JANTX2N3735](#) [JANSR2N2222AUB](#)
[CMLT3946EG TR](#) [SNSS40600CF8T1G](#) [CMLT3906EG TR](#) [GRP-DATA-JANS2N2907AUB](#) [GRP-DATA-JANS2N2222AUA](#)
[MMDT3946FL3-7](#) [2N4240](#) [MSB30KH-13](#) [2N2221AUB](#) [2SD1815T-TL-E](#)