

ANDERSON
POWER
PRODUCTS

POWERCLAW

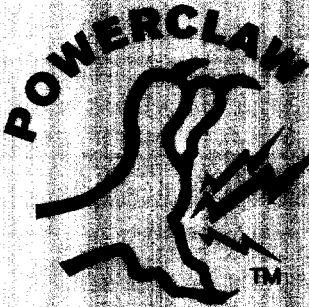

Quick disconnect

Thinned plates

Snap-On installation

Fully insulated plastic housing

UL recognized and CSA approved

Hot Protection

Multiple color-coding and marking

Anti-static (ESD) protection

Warning protection

The Powerclaw™

The Powerclaw™ series of connectors was designed to meet the high power requirements of the communications industry. The revolutionary three-claw attachment provides the contact surface-area needed for high board-level power. The contact is tin-lead plated to minimize contact resistance at high current and to ease soldering to the PCB.

In addition, Powerclaw's modular construction makes connecting and disconnecting a snap. The Powerclaw connectors allow a safe and convenient "hot swapping" when maintenance of the equipment is required. The connector's UL94V0 rated thermoplastic housing protects the operator, while the screw-less, snap-in connector system easily disconnects, eliminating the need for a professional electrician. These features make the Powerclaw connector system ideal for circuit card or cabinet applications because they facilitate equipment N+1 power redundancy.

The Powerclaw connectors can be mated with APP's standard 75-amp Powerpole, locking 75-amp Powerpole, and standard SB50 connectors. The single-pole configuration of the Powerclaw and Locking Powerclaw connectors is rated at 55 amps, while the two-pole SB Powerclaw connector is rated at 50 amps per pole. The high-power PCB Powerclaw connector joins APP's proven family of 25-amp PCB contacts, applicable in APP's 15/45 amp Powerpoles.



ANPPS00009

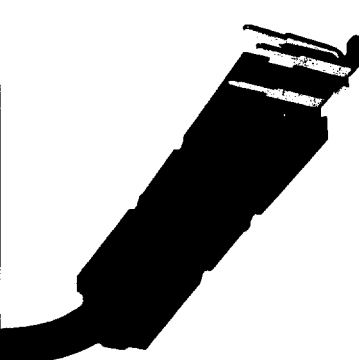
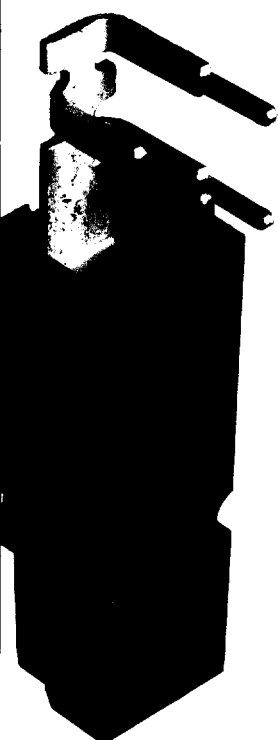

PRODUCT INFORMATION

| | PP Powerclaw | SB Powerclaw | Locking Powerclaw |
|--|---|---|---|
| Maximum Current (per Tin-Lead Contact) | 55 amps | 50 amps | 55 amps |
| Maximum Voltage (AC or DC) | 600 volts | 600 volts | 600 volts |
| Housing Material | Polycarbonate | Polycarbonate | Polycarbonate |
| Contact Material | Copper per ASTM-B-152 | Copper per ASTM-B-152 | Copper per ASTM-B-152 |
| Contact Plating: Tin-Lead | .100 micro" 60/40 Pb-Sn over .050 micro" Ni | .100 micro" 60/40 Pb-Sn over .050 micro" Ni | .100 micro" 60/40 Pb-Sn over .050 micro" Ni |
| Contact Plating: Silver* | .100 micro Au over .050 micro" Ni | .100 micro Au over .050 micro" Ni | .100 micro Au over .050 micro" Ni |
| Mating/Unmating Forces | 7 lb. Average | 15 lb. Average | 7 lb. Average |
| Suggested Board Thickness | .150" max. | .150" max. | .150" max. |

*Silver is a custom option; Tin-lead plating is standard

HIGH POWER PCB CONTACTS

| Test Condition | Specification Tested to and Met: |
|-----------------------------------|--|
| Mechanical | |
| Sine Vibration | MIL-STD-1344, Method 2005, Test Condition I. |
| Mechanical Shock | MIL-STD-1344, Method 2004, Test Condition I. |
| Mating Force | APP Specification, 7 lb average mating force. |
| Durability | APP Specification, no base metal exposed after 50 cycles |
| Electrical | |
| Temperature Rise at rated current | UL 1977 |
| Dielectric Voltage Withstand | MIL-STD-1344, Method 3001, Type 1. |
| Contact Resistance | MIL-STD-1344, Method 3004, Type 1. |
| Thermal | |
| Temperature Cycling | MIL-STD-1344, Method 1003, Test Condition A. |
| Humidity | MIL-STD-1344, Method 3001, Type 1. |
| Flammability | |
| PP-, LP-, SB-series | UL 94, 94VO. |

PART NUMBER INFORMATION

| | | | | | | |
|-------------|---|--|---|-------------------|---|---|
| PC | — | XXX | — | X | — | XX |
| (Powerclaw) | | (Color) | | (Plating) | | (Housing) |
| | | BLK-Black RED-Red BLU-Blue WHT-White GRY-Gray GRN-Green | | T-Tin S-Silver | | PP-Powerpole 75 amp LP-Locking Powerpole 75 amp SB-SB50 amp |

Example: Blue 75 amp locking Powerclaw with tin plating (PC-BLU-T-LP)

Powerclaw Mounting Staples

PC Staple 1 = 1 pole mounting staple

PC Staple 2 = 2 pole mounting staple



POWERCLAW FEATURES

Quick disconnect avoids need for system maintenance or calibrated torquing

Tin-lead plated for easy soldering and minimal contact resistance at high current

Snap-On Interface ensures foolproof assembly and proper connection

Fully insulated plastic housing provides the user with a safe connection

UL recognized and CSA approved for certified workmanship and reliability

Meets UL hot-spark requirements so that equipment can be hot swapped

Mating connector accepts wire gauges from #10 to #6 for design flexibility

Multiple color-coding and keying provides design flexibility

Anti-static packaging meets electronics PCB requirements

Vacuum packaging prevents tarnishing of contacts during shelf life



TEMPERATURE RISE

Temperature Rise at Constant Currents: Powerclaw™

Tested in Accordance with EIA 364-70, No enclosure, 25+/-5 deg. C. ambient
(#8 AWG Foil on Board Side, #6 AWG conductor on wire side, Contact Cat. No. 5900)

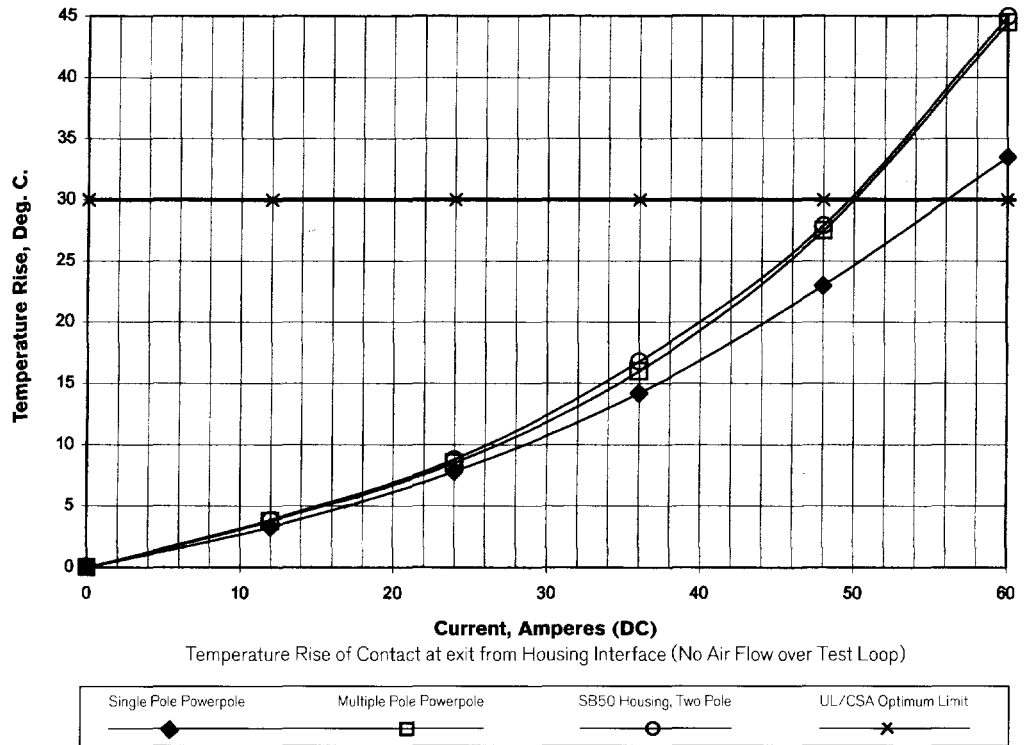

P A C K A G I N G

Modular high "Power to the Board"



"Powerclaw Packaging"
(Orders will be shipped in silver, non-transparent, plastic bags.)

Powerclaw connectors (PP, Locking, SB) are packaged in ESD plastic and foam for easy assembly use compatible with the electronics market requirements. The packaging is vacuum sealed, which prevents any tarnishing or environmental reactions to occur on the contact. The vacuum pack is easily opened at assembly by puncturing the bag. Each bag will be labeled and bar-coded for convenient assembly count.

PACKAGING QUANTITIES

PP Powerclaw 20 per bag
Locking Powerclaw 20 per bag
SB Powerclaw 10 per bag

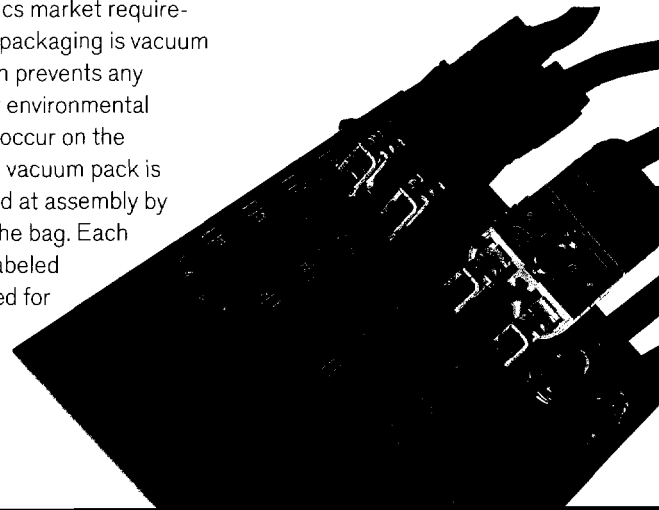

P O W E R C L A W S P E C I F I C A T I O N S

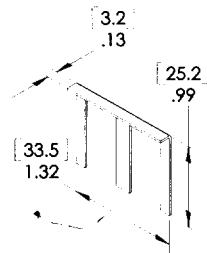
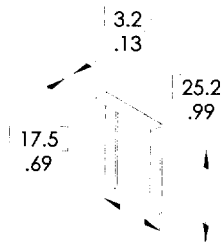
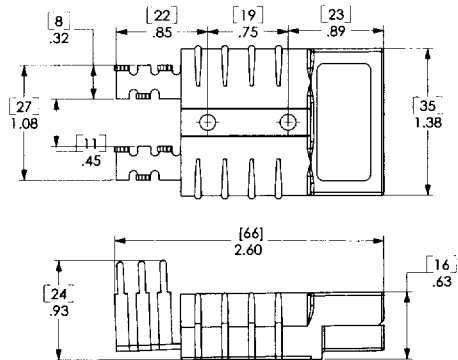
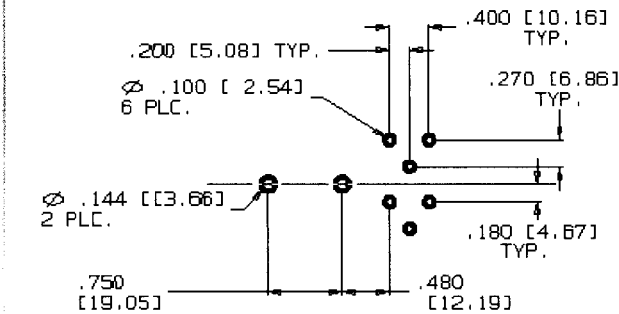
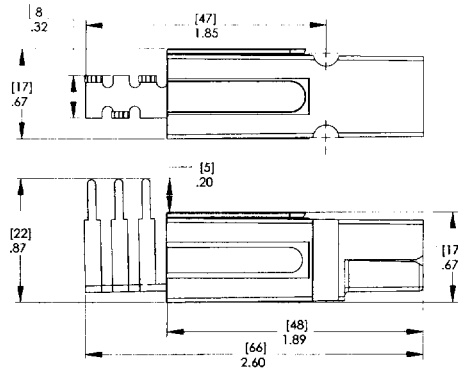
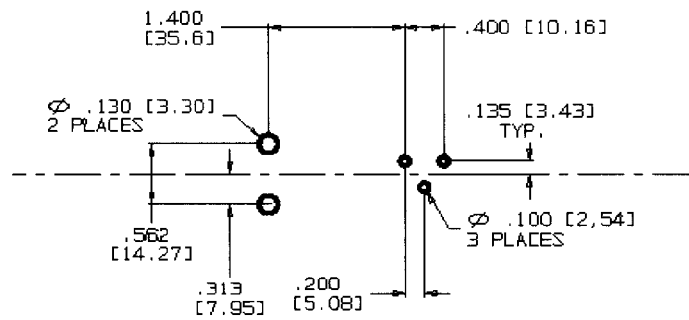
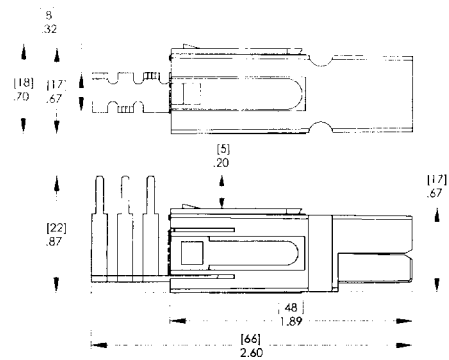
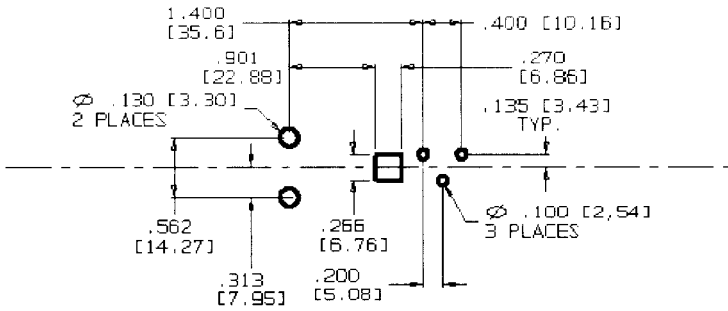

GENERAL INSTALLATION INSTRUCTIONS

1. Install Powerlaw assembly onto circuit board and verify proper insertion of leads through the circuit board.
2. Slide staple over Powerlaw or Locking Powerlaw or insert mounting screws into SB Powerlaw* and insert into board.
3. Fasten staple by bending the leads on the opposite side of the board. Fasten screws by use of proper nuts on opposite side of board.
4. Verify that the edge of the Powerlaw contact touches the edge of the housing on the top face. This insures proper contact alignment in housing.
5. Solder circuit board leads by wave or hand soldering. We suggest performing solder reflow operations prior to insertion and installation of Powerlaw connectors.

* Screws not included in connector; suggested size 6-32UNC.

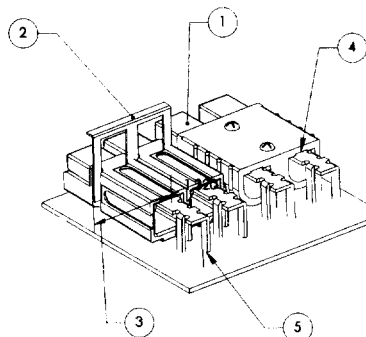

X-ON Electronics

Largest Supplier of Electrical and Electronic Components

Click to view similar products for [Heavy Duty Power Connectors](#) category:

Click to view products by [Anderson Power Products](#) manufacturer:

Other Similar products are found below :

[647757-1](#) [6643411-1](#) [6646058-2](#) [6646137-1](#) [6646138-1](#) [6646479-1](#) [6646608-1](#) [6646786-1](#) [6646940-1](#) [6651091-1](#) [6651525-1](#) [6651529-1](#)
[6651788-1](#) [696475-1](#) [73000005059](#) [73000005642](#) [765-15-0080A](#) [765-16-0080B](#) [829992-1](#) [902-77-02113](#) [129-1J](#) [AN0024023](#) [E6374G1](#)
[e6389g2](#) [157-43GW8](#) [MS3117-14AC](#) [1643543-1](#) [1650540-1](#) [1651811-2](#) [1766260-1](#) [1766282-1](#) [1766966-1](#) [1791340000](#) [NLDFT-3-BL-L-](#)
[S120-M40A](#) [NLDFT-N-W-L-C240-M40B](#) [NLS-2-R-C240-M40B](#) [NLS-N-W-C240-M40B](#) [NPS-3-BL-T6](#) [1986615-1](#) [2-1589900-8](#) [2199314-1](#)
[KA8102](#) [9300480317](#) [SBS50BRN#6](#) [29131](#) [29652](#) [1646905-1](#) [1648320-1](#) [1648582-1](#) [1650195-2](#)