

1200V N-Channel Silicon Carbide Power MOSFET



1. Applications

- Asymmetrical Bridge Converter
- Inverter
- Single Switch Forward Flyback



2. Features

- Low drain-source on-resistance: $R_{DS(ON)} = 40\text{m}\Omega$ (typ.)
- Easy to control Gate switching
- Enhancement mode: $V_{th} = 2$ to 4 V

Table 1 Key Performance Parameters

Parameter	Value	Unit
$V_{DS} @ T_{j,max}$	1200	V
$R_{DS(on),max}$	45	m Ω
$Q_{g,typ}$	103	nC
$I_{D,pulse}$	182	A

3. Packaging and Internal Circuit

Part Name	Package	Marking
ADQ120N040G2	TO-247-4L	ADQ120N040G2

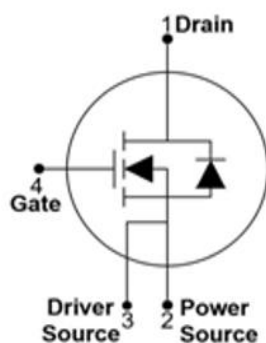
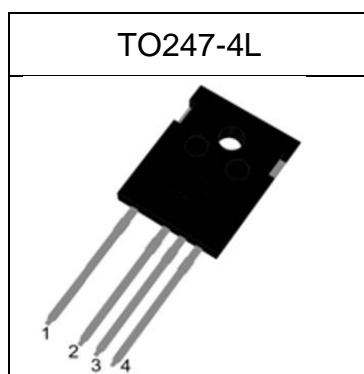

Released

1 Maximum ratings

at $T_j = 25^\circ\text{C}$, unless otherwise specified

Table 2 Maximum ratings

Parameter	Symbol	Values			Unit	Note / Test Condition
		Min.	Typ.	Max.		
Continuous drain current ¹⁾	I_D	-	-	68	A	$T_C=25^\circ\text{C}$
		-	-	50	A	$T_C=100^\circ\text{C}$
Avalanche energy, single pulse	E_{AS}	-	-	840	mJ	$T_C=25^\circ\text{C}$, $V_{DD}=50\text{V}$, $L=1\text{mH}$, $R_G=25\Omega$
Gate source voltage (static)	V_{GS}	-5	-	20	V	static;
Power dissipation	P_{tot}	-	-	247	W	$T_C=25^\circ\text{C}$
Derating factor above 25°C		-	-	2.1	W/ $^\circ\text{C}$	
Storage temperature	T_{stg}	-55	-	175	$^\circ\text{C}$	
Operating junction temperature	T_j	-55	-	175	$^\circ\text{C}$	
Soldering Temperature Distance of 1.6mm from case for 10s	T_L			300	$^\circ\text{C}$	
Transconductance	GFS	-	6.3	-	S	$V_{DS}=20\text{V}$ $I_{DS}=20\text{A}$
		-	5.1	-		$V_{DS}=20\text{V}$ $I_{DS}=20\text{A}$, $T_j=150^\circ\text{C}$

¹⁾Limited by $T_{j,max}$. Maximum Duty Cycle $D = 0.50$

²⁾Pulse width t_p limited by $T_{j,max}$

³⁾Identical low side and high side switch with identical R_G

Released

2 Thermal characteristics

Table 3 Thermal characteristics

TO247

Parameter	Symbol	Values			Unit	Note / Test Condition
		Min.	Typ.	Max.		
Thermal resistance, junction - case	R_{thJC}	-	0.62	0.8	°C/W	-
Thermal resistance, junction - ambient	R_{thJA}	-	-	40	°C/W	device on PCB, minimal footprint

Released

3 Electrical characteristics

at $T_j=25^\circ\text{C}$, unless otherwise specified

Table 4 Static characteristics

Parameter	Symbol	Values			Unit	Note / Test Condition
		Min.	Typ.	Max.		
Drain-source breakdown voltage	$V_{(BR)DSS}$	1200	-	-	V	$V_{GS}=0V, I_D=1mA$
Gate threshold voltage	$V_{(GS)th}$	2.0	2.8	4.0	V	$V_{DS}=V_{GS}, I_D=10mA$
Zero gate voltage drain current	I_{DSS}	-	-	1	μA	$V_{DS}=1200V, V_{GS}=0V$
Gate-source leakage current	I_{GSS+}	-	-	100	nA	$V_{GS}=20V, V_{DS}=0V$
Gate-source leakage current	I_{GSS-}	-	-	-100	nA	$V_{GS}=-5V, V_{DS}=0V$
Drain-source on-state resistance	$R_{DS(on)}$	-	40	45	$m\Omega$	$V_{GS}=20V, I_D=20A, T_j=25^\circ\text{C}$
		-	46	-		$V_{GS}=20V, I_D=20A, T_j=150^\circ\text{C}$
Gate resistance (Intrinsic)	R_G	-	2.1	-	Ω	$f=1\text{MHz}$, open drain

Table 5 Dynamic characteristics

Parameter	Symbol	Values			Unit	Note / Test Condition
		Min.	Typ.	Max.		
Input capacitance	C_{iss}	-	2479	-	pF	$V_{GS}=0V, V_{DS}=1000V, f=200\text{KHz}$
Output capacitance	C_{oss}	-	112	-	pF	$V_{GS}=0V, V_{DS}=1000V, f=200\text{KHz}$
Reverse transfer capacitance	C_{rss}	-	7	-	pF	$V_{GS}=0V, V_{DS}=1000V, f=200\text{KHz}$
Turn-on delay time	$t_{d(on)}$	-	16	-	ns	$V_{DD}=800V, V_{GS}=20V,$ $I_D=20A, R_G=0\Omega;$ $T_j=25^\circ\text{C}$
Rise time	t_r	-	9	-	ns	
Turn-off delay time	$t_{d(off)}$	-	25	-	ns	
Fall time	t_f	-	15	-	ns	
Turn-on Switching Energy	E_{on}		1496		μJ	
Turn-off Switching Energy	E_{off}		92		μJ	

Table 6 Gate charge characteristics

Parameter	Symbol	Values			Unit	Note / Test Condition
		Min.	Typ.	Max.		
Gate to source charge	Q_{gs}	-	35	-	nC	$V_{DD}=800V, I_D=20A, V_{GS}=20V$
Gate to drain charge	Q_{gd}	-	32	-	nC	$V_{DD}=800V, I_D=20A, V_{GS}=20V$
Gate charge total	Q_g	-	103	-	nC	$V_{DD}=800V, I_D=20A, V_{GS}=20V$

Released

Table 7 Reverse diode characteristics

Parameter	Symbol	Values			Unit	Note / Test Condition
		Min.	Typ.	Max.		
Continuous Source Current	I_{SD}	-	-	68	A	
Diode forward voltage	V_{SD}	-	3.0	-	V	$I_S = 10A, V_{GS} = 0V, T_J = 25^\circ C$
Reverse recovery time	t_{rr}	-	91	-	ns	$V_{DD} = 800V, I_D = 20A, +V_{GS} = +15V, -V_{GS} = -4V$ $L_{Load} = 500\mu H, R_g = 0\Omega, T_J = 25^\circ C$
Reverse recovery charge	Q_{rr}	-	312	-	nC	
Peak reverse recovery current	I_{rrm}	-	10.8	-	A	

Released

4 Electrical characteristics diagram

Diagram 1: Typ. output characteristics

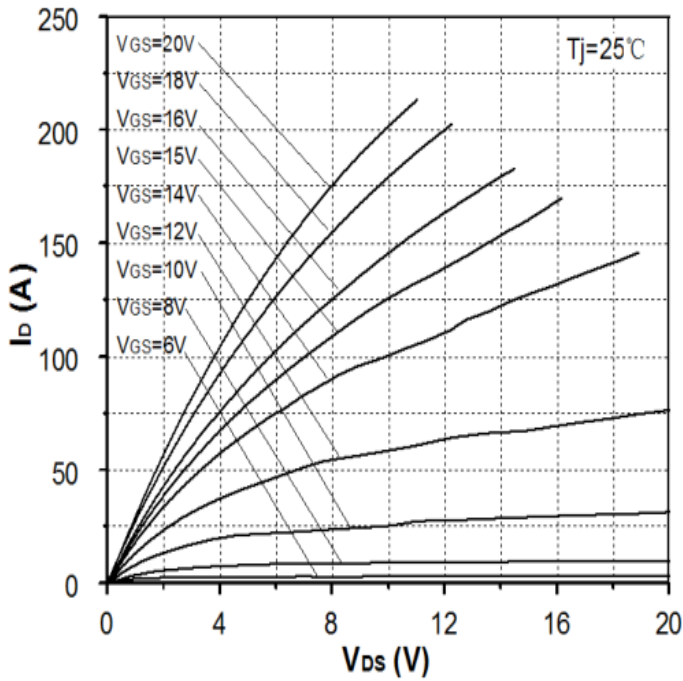

$I_D = f(V_{DS}); T_j = 25^\circ\text{C}$; parameter: V_{GS}

Diagram 2: Typ. output characteristics

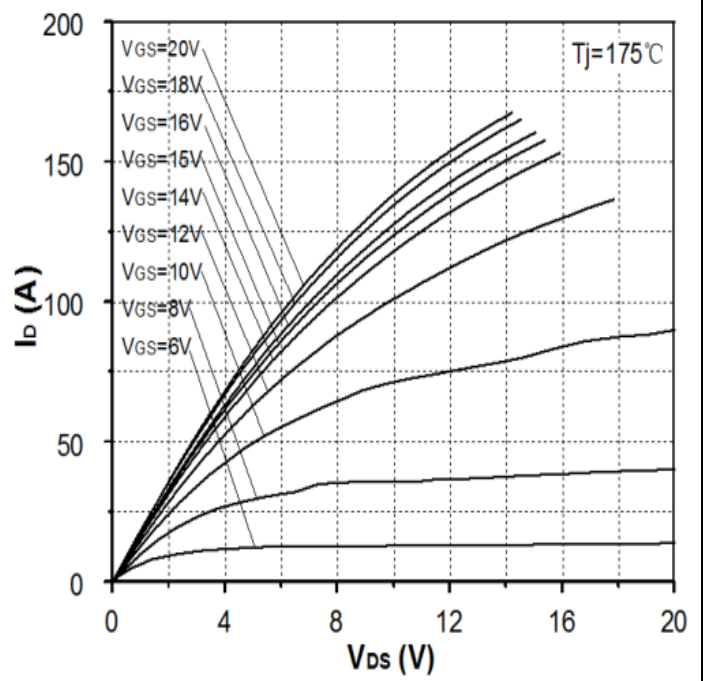

$I_D = f(V_{DS}); T_j = 175^\circ\text{C}$; parameter: V_{GS}

Diagram 3: Typ. transfer characteristics

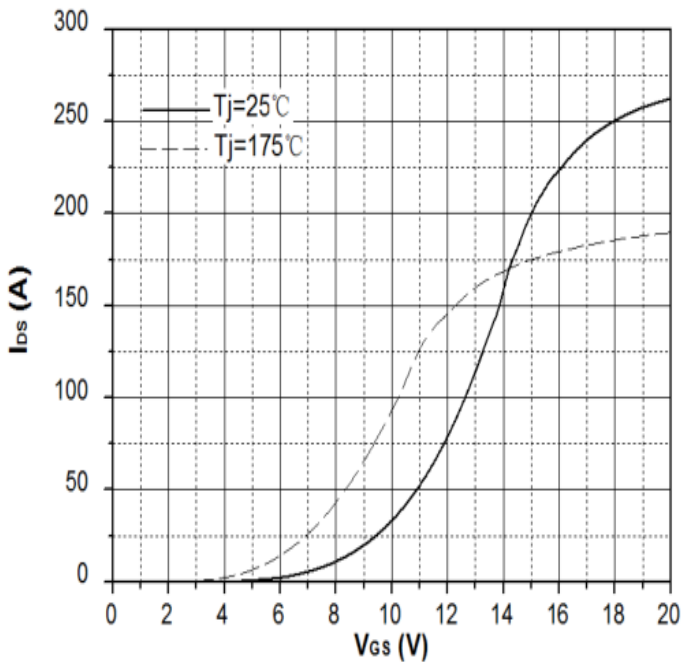

$I_D = f(V_{GS}); V_{DS} = 20\text{V}$; parameter: T_j

Diagram 4: Typ. gate charge

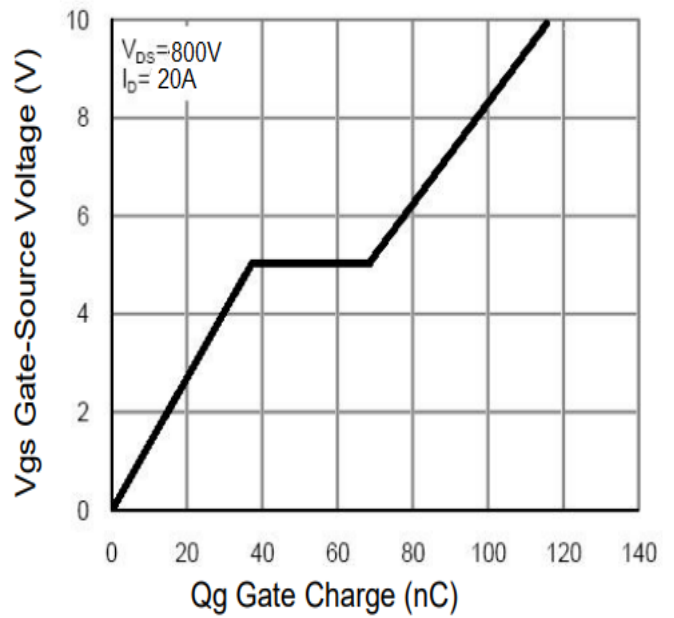

$V_{GS} = f(Q_{gate}); I_D = 20\text{A}$; $V_{DS} = 800\text{V}$; turn-on pulse

Released

Diagram 5: Typical gate-source threshold voltage as a function of junction temperature

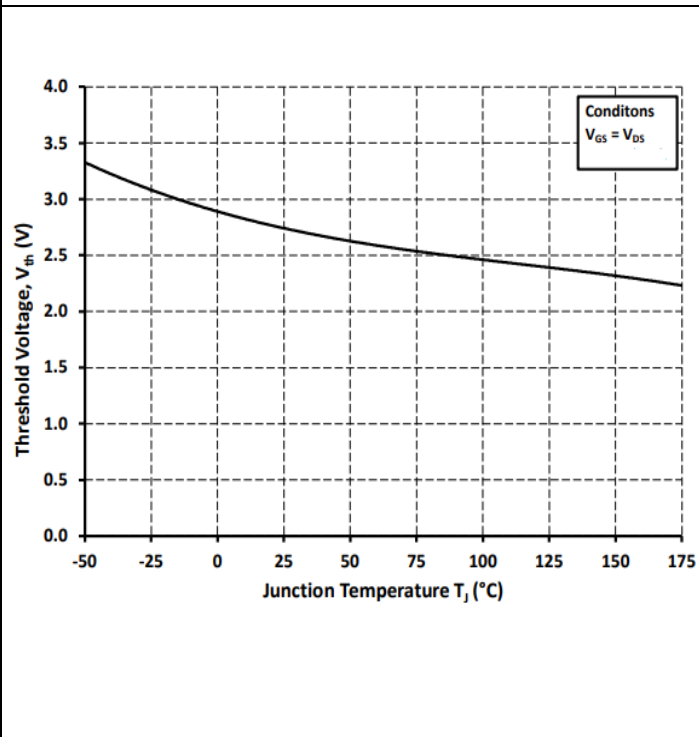

$V_{GS(th)}=f(T_j)$; $I_{DS}=10mA$; $V_{GS}=V_{DS}$

Diagram 6: Typ. Capacitance as a function of drain-source voltage

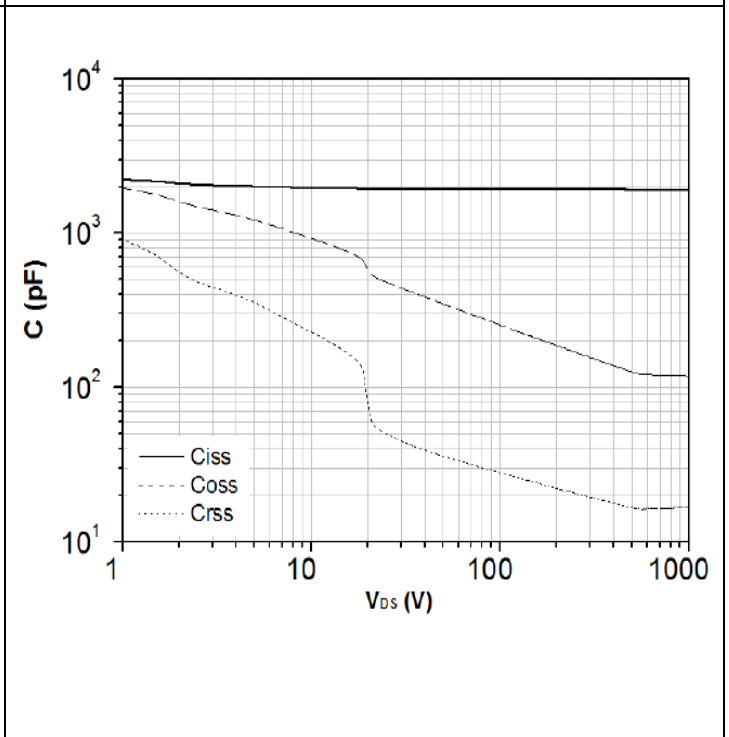

$C=f(V_{DS})$; $V_{GS}=0V$; $f=1MHz$

Diagram 7: Normalized on-resistance as a function of junction temperature

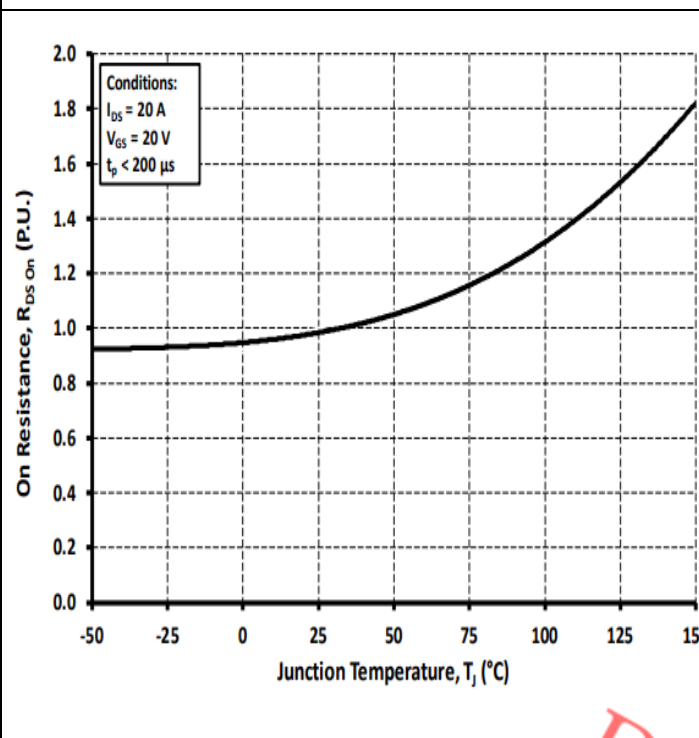

$R_{DS(ON)}=f(T_j)$; $I_{DS}=20A$

Diagram 8: Typical body diodes forward voltage as function of junction temperature

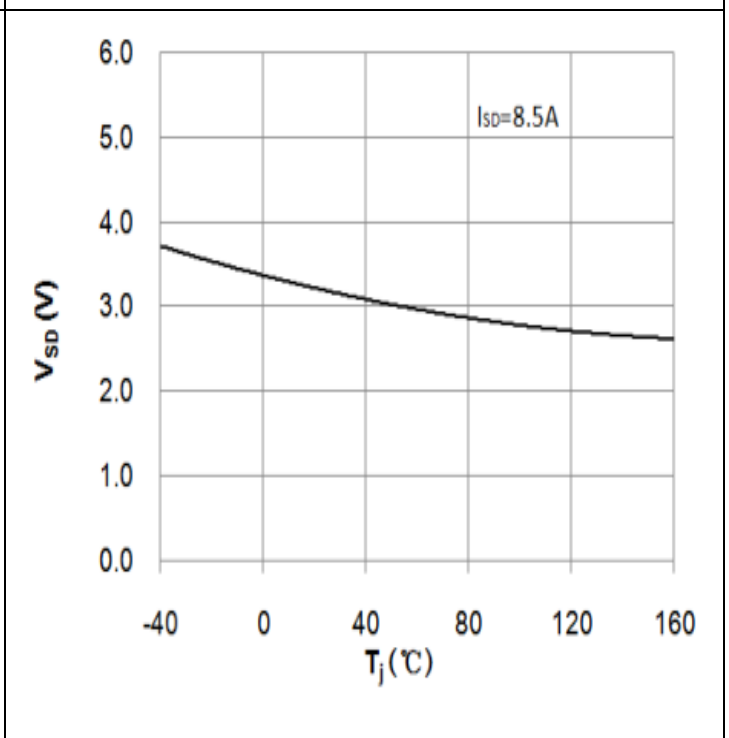

$V_{SD}=f(T_j)$; $V_{GS}=0V$; $I_{SD}=10A$

Released

Diagram 9: Typical body diodes forward current as function of forward voltage, V_{GS} as parameter

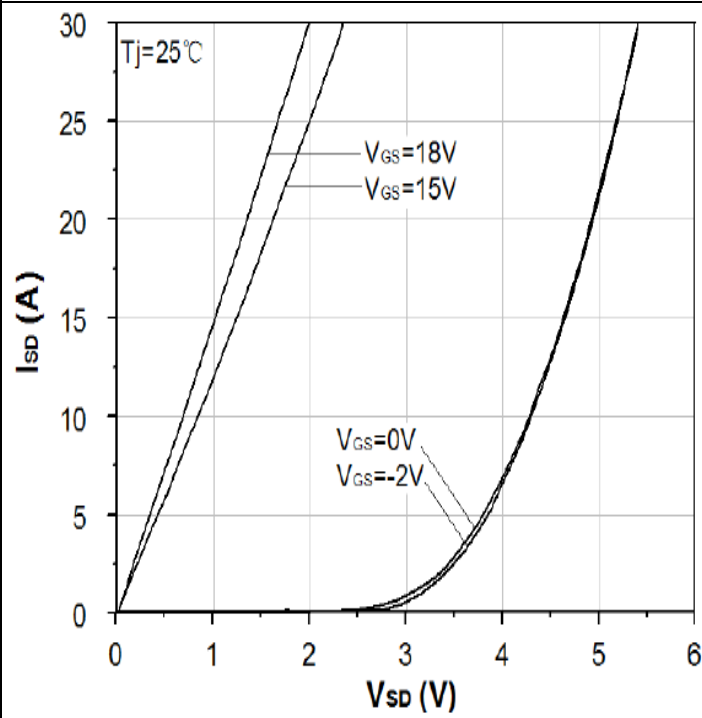

$I_{SD} = f(V_{SD}); T_j = 25^\circ\text{C}$

Diagram 10: Typical body diodes forward current as function of forward voltage, V_{GS} as parameter

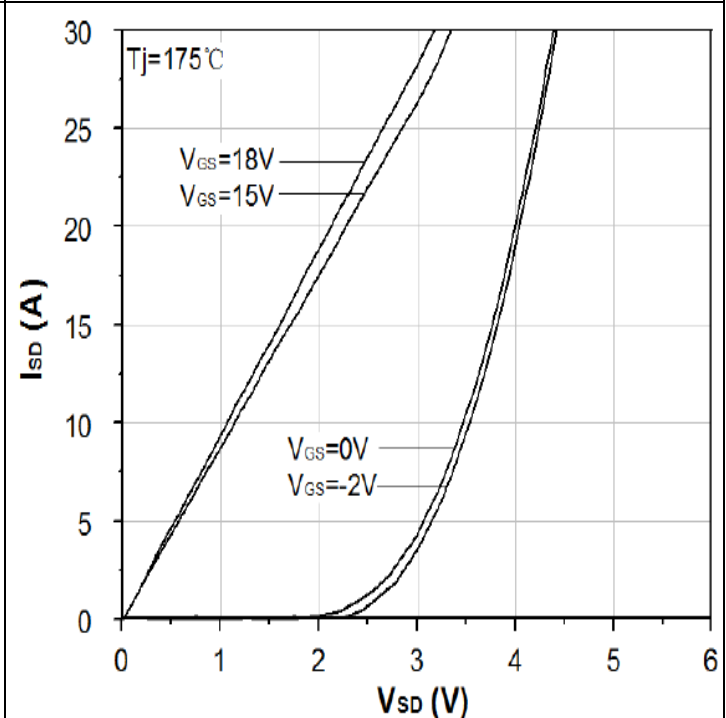

$I_{SD} = f(V_{SD}); T_j = 175^\circ\text{C}$

Diagram 11: Safe operating area(SOA)

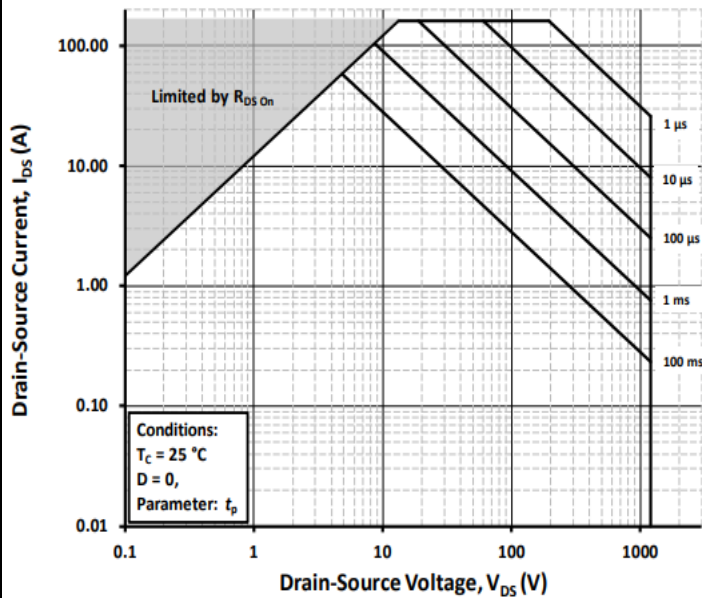

$V_{GS} = 0/18\text{V}; T_c = 25^\circ\text{C}; T_j < 175^\circ\text{C}$

Diagram 12: Power dissipation as a function of case temperature limited by bond wire

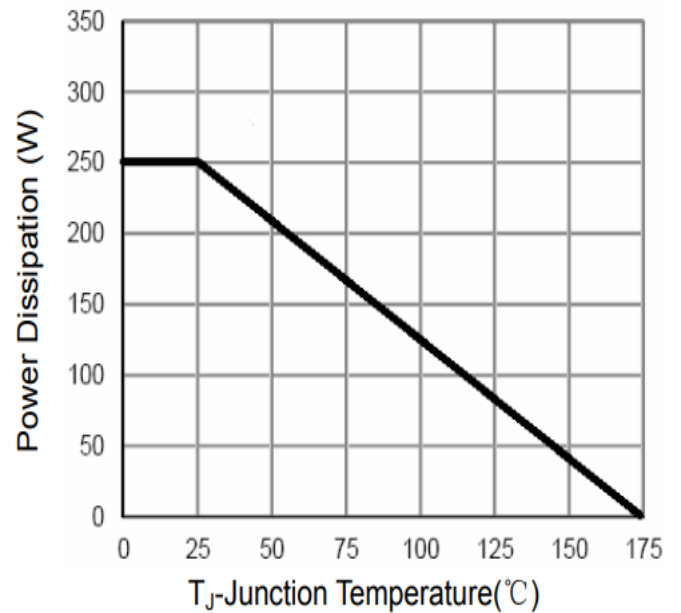

$P_{tot} = f(T_c)$

Released

Diagram 13: Maximum DC drain to source current as a function of case temperature limited by bond wire

Diagram 14: Maximum source to drain current as a function of case temperature limited by bond wire

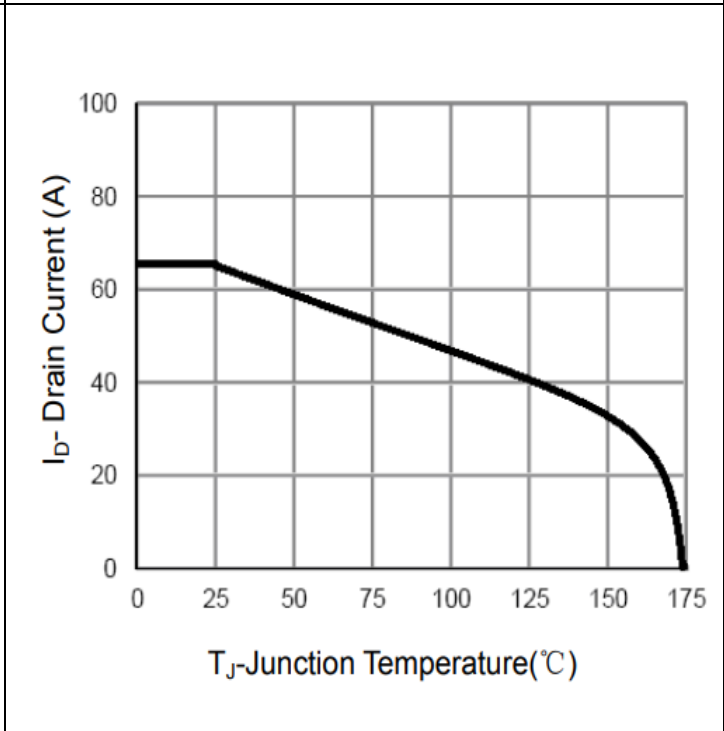
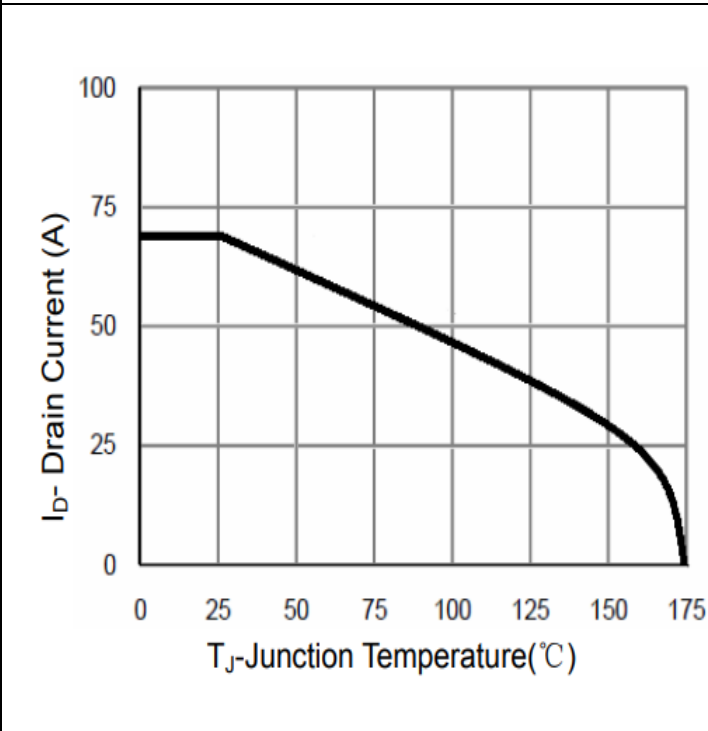

$I_{DS} = f(T_C)$

$I_{SD} = f(T_C), V_{GS}=0V$

Diagram 15: Max. transient thermal resistance(MOSFET/diodes)

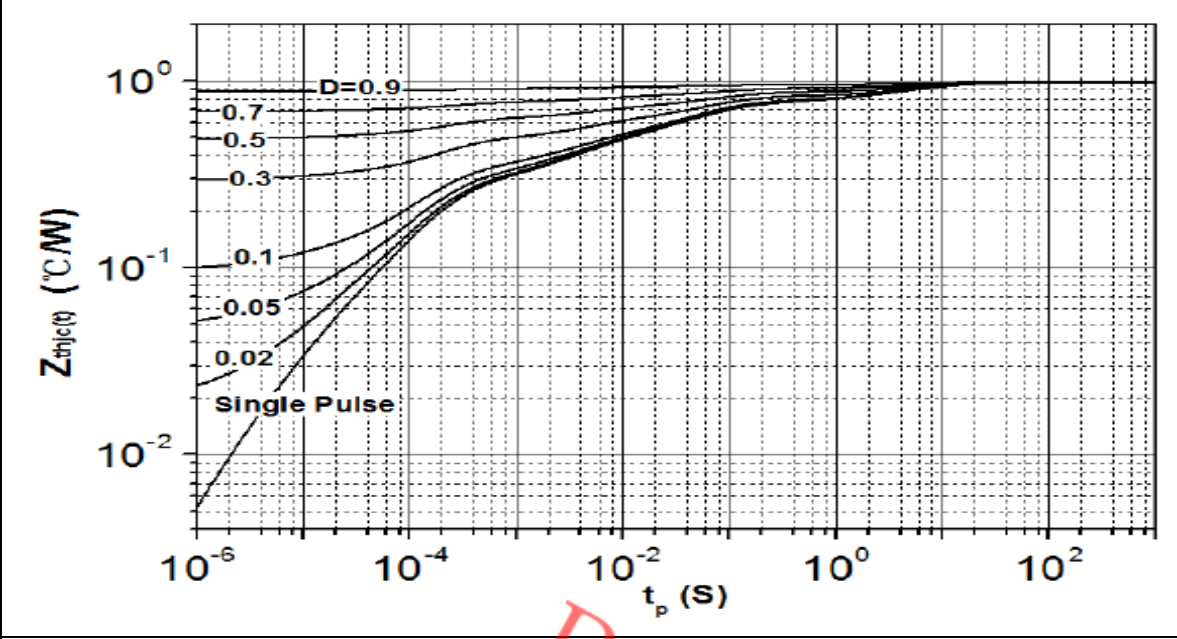

$Z_{th(j-c,max)} = f(t_p), \text{parameter } D = t_p/T$

Released

5 Test Circuits

Table 8 Diode characteristics

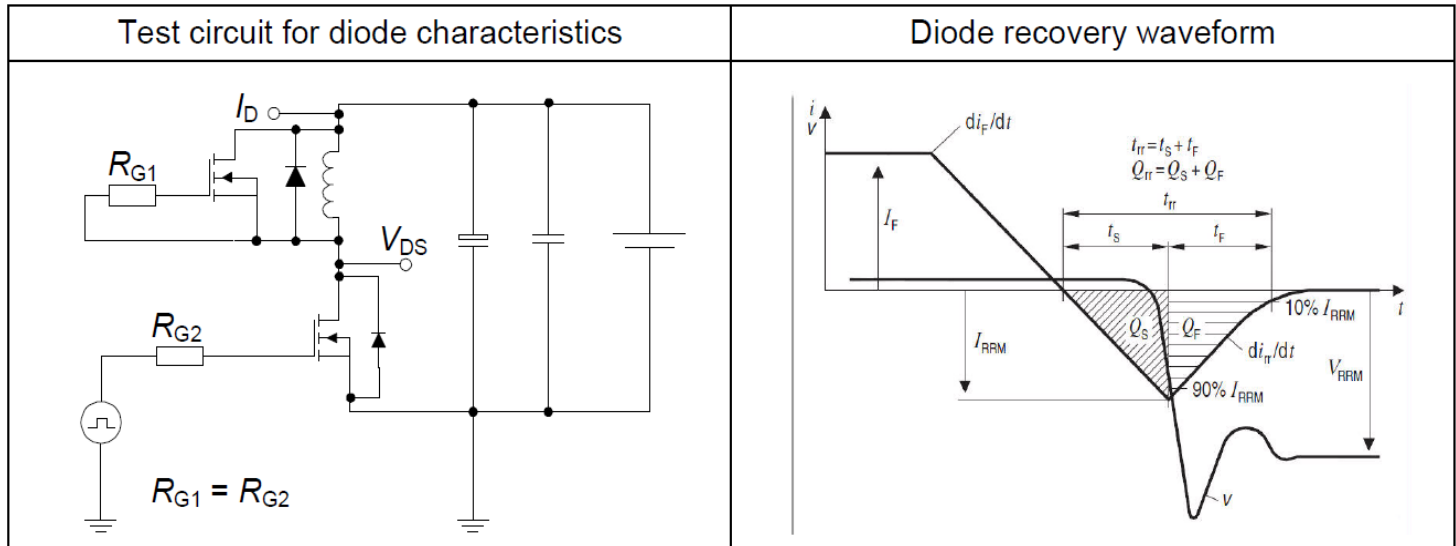
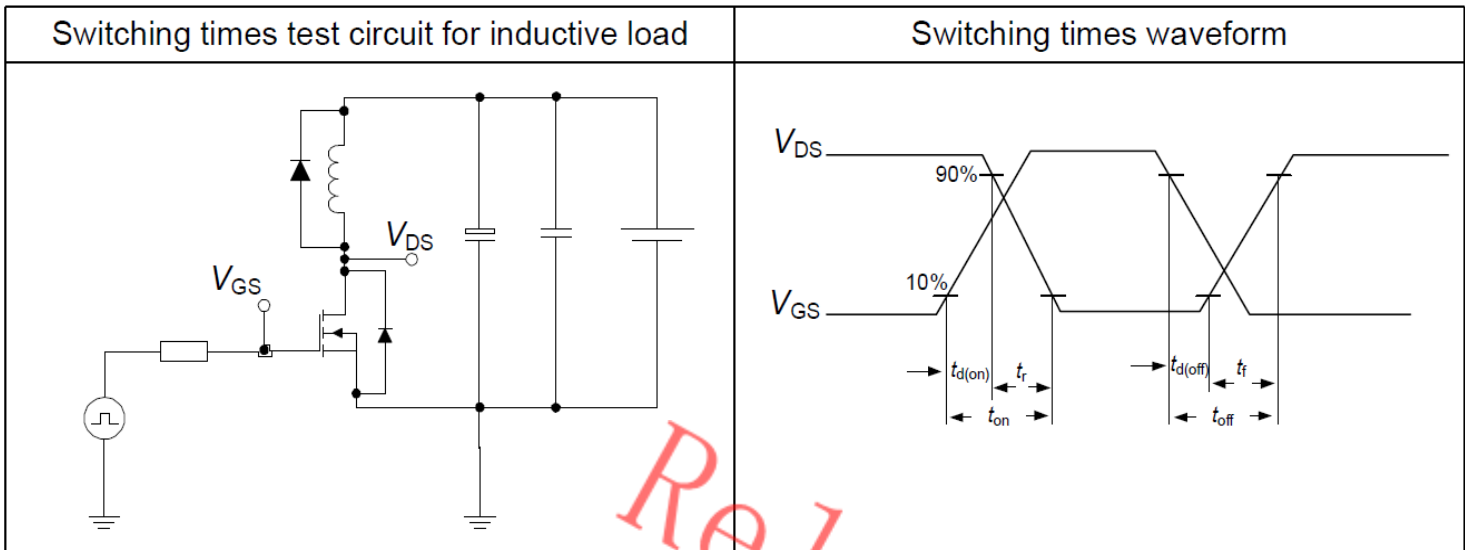

Table 9 Switching times



Released

6 Package Outlines

TO-247-4L

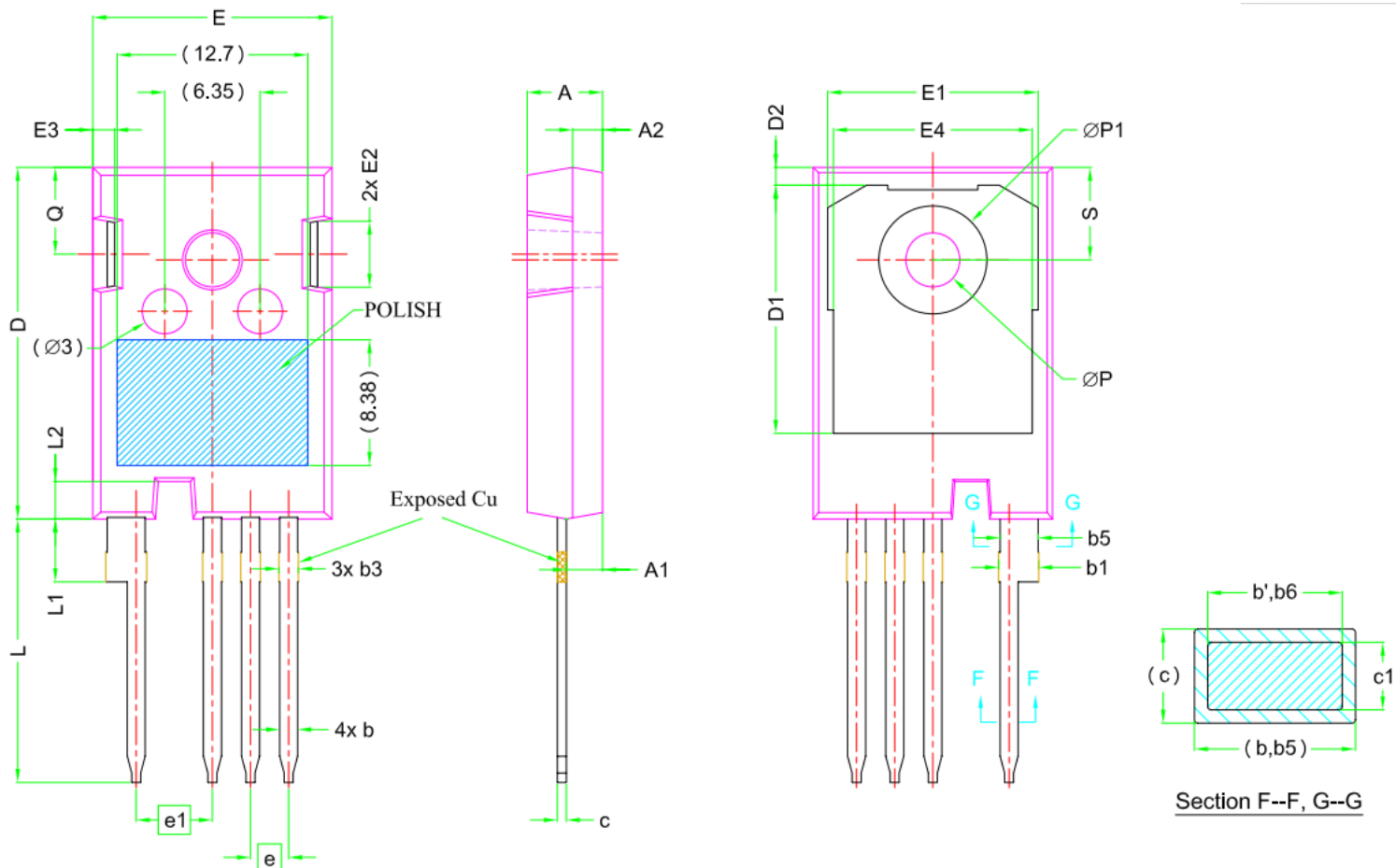

SYMBOL	DIMENSIONS		
	MIN.	NOM.	MAX.
A	4.83	5.02	5.21
A1	2.29	2.41	2.54
A2	1.91	2.00	2.16
b'	1.07	1.20	1.28
b	1.07	1.20	1.33
b1	2.39	2.67	2.94
b3	1.07	1.30	1.60
b5	2.39	2.53	2.69
b6	2.39	2.53	2.64
c	0.55	0.60	0.68
c1	0.55	0.60	0.65
D	23.30	23.45	23.60
D1	16.25	16.55	17.65
D2	0.95	1.19	1.25
E	15.75	15.94	16.13
E1	13.10	14.02	14.15
E2	3.68	4.40	5.10
E3	1.00	1.45	1.90
E4	12.38	13.26	13.43
e	2.54 BSC		
e1	5.08 BSC		
L	17.31	17.57	17.82
L1	3.97	4.19	4.37
L2	2.35	2.50	2.65
ØP	3.51	3.61	3.65
ØP1	7.19 REF.		
Q	5.49	5.79	6.00
S	6.04	6.17	6.30

Released

Revision History

Revision	Date	Subjects (major changes since last revision)
1.0	2022-10-21	Preliminary version

Released

X-ON Electronics

Largest Supplier of Electrical and Electronic Components

Click to view similar products for [MOSFET](#) category:

Click to view products by [ANHI](#) manufacturer:

Other Similar products are found below :

[IRFD120](#) [IRFY240C](#) [JANTX2N5237](#) [BUK455-60A/B](#) [MIC4420CM-TR](#) [VN1206L](#) [NDP4060](#) [SI4482DY](#) [IPS70R2K0CEAKMA1](#)
[SQD23N06-31L-GE3](#) [TK16J60W,S1VQ\(O](#) [2SK2614\(TE16L1,Q\)](#) [DMN1017UCP3-7](#) [EFC2J004NUZTDG](#) [DMN1053UCP4-7](#) [SQJ469EP-](#)
[T1-GE3](#) [NTE2384](#) [DMC2700UDMQ-7](#) [DMN2080UCB4-7](#) [DMN61D9UWQ-13](#) [US6M2GTR](#) [DMN31D5UDJ-7](#) [DMP22D4UFO-7B](#)
[DMN1006UCA6-7](#) [DMN16M9UCA6-7](#) [STF5N65M6](#) [IRF40H233XTMA1](#) [STU5N65M6](#) [DMN6022SSD-13](#) [DMN13M9UCA6-7](#)
[DMTH10H4M6SPS-13](#) [DMN2990UFB-7B](#) [IPB80P04P405ATMA2](#) [2N7002W-G](#) [MCAC30N06Y-TP](#) [MCQ7328-TP](#) [NTMC083NP10M5L](#)
[NVMFS2D3P04M8LT1G](#) [BXP7N65D](#) [BXP4N65F](#) [AOL1454G](#) [WMJ80N60C4](#) [BXP2N20L](#) [BXP2N65D](#) [BXT1150N10J](#) [BXT1700P06M](#)
[TSM60NB380CP](#) [ROG](#) [RQ7L055BGTCR](#) [DMNH15H110SK3-13](#) [SLF10N65ABV2](#)