

Trench-FS Cool-Watt® II IGBT



- Applications
 - Inverter power supply
 - UPS
 - PV

- Features

- CoolWatt® II Trench-FS technology
- Low V_{CESAT}
- Low switching losses
- With anti-parallel fast recovery diode
- Positive temperature coefficient
- High reliability

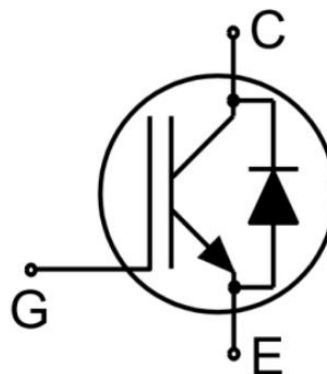
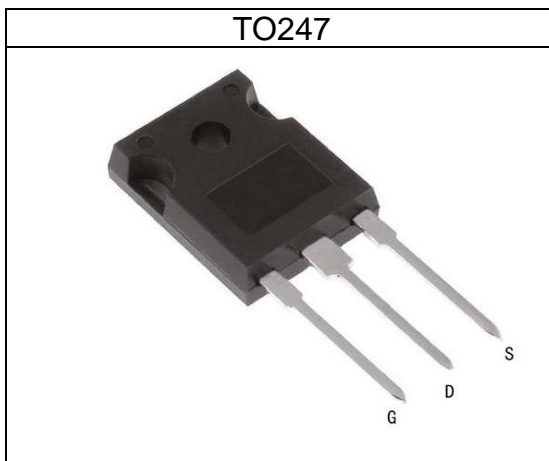

Table 1 Key Performance Parameters

Parameter	Value	Unit
V_{CES}	650	V
$V_{CE(sat)}$	1.3	V
$V_{GE(th)}$	5.6	V
$Q_{g,typ}$	142	nC
I_{Cpuls}	225	A

3. Packaging and Internal Circuit

Part Name	Package	Marking
AGW75N65	TO247	AGW75N65



1 Maximum ratings

at $T_j = 25^\circ\text{C}$, unless otherwise specified

Table 2 Maximum ratings

Parameter	Symbol	Values			Unit	Note / Test Condition
		Min.	Typ.	Max.		
Collector-emitter voltage	V_{CES}	650	-	-	V	$T_C=25^\circ\text{C}$
DC collector current	I_C		-	150	A	$T_C=25^\circ\text{C}$
			-	75	A	$T_C=100^\circ\text{C}$
Pulse collector current	I_{Cpuls}	-	-	225	A	$T_{vj}\leq 150^\circ\text{C}$
Repetitive peak reverse voltage	V_{RRM}	650	-		V	$T_C=25^\circ\text{C}$
Diode continuous forward current	I_F	-	-	150	A	$T_C=25^\circ\text{C}$
		-	-	75	A	$T_C=100^\circ\text{C}$
Diode pulse current	I_{Fpuls}	-	-	225	A	$T_{vj}\leq 150^\circ\text{C}$
Gate-emitter voltage	V_{GE}	-20	-	20	V	static;
		-30	-	30	V	Transient ($t_p\leq 10\mu\text{s}, D<0.01$)
Power dissipation	P_{tot}	-	-	469	W	$T_C=25^\circ\text{C}$
Storage temperature	T_{stg}	-50	-	150	$^\circ\text{C}$	
Operating junction temperature	T_j	-40	-	175	$^\circ\text{C}$	
Soldering Temperature Distance of 1.6mm from case for 10s	T_L			260	$^\circ\text{C}$	

2 Thermal characteristics

Table 3 Thermal characteristics

Parameter		Symbol	Values			Unit	Note / Test Condition
			Min.	Typ.	Max.		
IGBT thermal resistance junction	- case	$R_{thJC-IGBT}$	-	-	0.32	K/W	-
FRD thermal resistance junction	- case	$R_{thJC-FRD}$	-	-	0.45	K/W	-
Thermal resistance junction	- ambient	R_{thJA}	-	-	40	K/W	-

3 Electrical characteristics

at $T_j=25^\circ\text{C}$, unless otherwise specified

Table 4 Static characteristics

Parameter	Symbol	Values			Unit	Note / Test Condition
		Min.	Typ.	Max.		
Collector-emitter breakdown voltage	$V_{(BR)CES}$	650	-	-	V	$V_{GE} = 0V, I_C=0.25mA, T_{vj}=25^\circ\text{C}$
Collector-emitter saturation voltage	$V_{CE(sat)}$	-	1.3	2	V	$V_{GE}=15V, I_C=30A, T_{vj}=25^\circ\text{C}$
		-	1.85	-	V	$V_{GE}=15V, I_C=30A, T_{vj}=150^\circ\text{C}$
Gate-emitter threshold voltage	$V_{GE(th)}$	5.1	5.6	6.1	V	$V_{GE}= V_{CE}, I_C=1.5mA, T_{vj}=25^\circ\text{C}$
Diode forward voltage	V_F	-	1.35	1.85	V	$V_{GE}= 0V, I_F=30A, T_{vj}=25^\circ\text{C}$
		-	1.2	-	V	$V_{GE}= 0V, I_F=30A, T_{vj}=150^\circ\text{C}$
Zero collector voltage gate current	I_{GES}	-	-	200	nA	$V_{GE}=30V, V_{CE}=0V$
Zero gate voltage collector current	I_{CES}	-	-	0.2	mA	$V_{CE} =650V, V_{GE}=0V, T_{vj}=25^\circ\text{C}$
		-	-	1.0	mA	$V_{CE} =650V, V_{GE}=0V, T_{vj}=150^\circ\text{C}$
Integrated gate resistor	R_{Gin}	—	0	—	Ω	—

Table 5 Dynamic characteristics

Parameter	Symbol	Values			Unit	Note / Test Condition
		Min.	Typ.	Max.		
Input capacitance	C_{ies}	-	3910	-	pF	$V_{GE} = 0V, V_{CE}= 30V, f = 1MHz, T_{vj}=25^\circ\text{C}$
Output capacitance	C_{oes}	-	244	-	pF	$V_{GE} = 0V, V_{CE}= 30V, f = 1MHz, T_{vj}=25^\circ\text{C}$
Reverse transfer capacitance	C_{res}	-	34.0	-	pF	$V_{GE} = 0V, V_{CE}= 30V, f = 1MHz, T_{vj}=25^\circ\text{C}$
Gate charge	Q_g	-	142	-	nC	$V_{GE}=0/15V, V_{cc}=400V, I_C=75A, T_{vj}=25^\circ\text{C}$
Gate-emitter charge	Q_{ge}	-	34.6	-	nC	$V_{GE}=0/15V, V_{cc}=400V, I_C=75A, T_{vj}=25^\circ\text{C}$
Gate-collector charge	Q_{gc}	-	63.0	-	nC	$V_{GE}=0/15V, V_{cc}=400V, I_C=75A, T_{vj}=25^\circ\text{C}$
Gate-emitter plateau voltage	$V_{GE(pl)}$	-	9.65	-	V	$I_C = 75A, V_{CE}=520V, V_{GE}=0/15V, T_{vj}=25^\circ\text{C}$

Table 6 Switching characteristics

Parameter	Symbol	Values			Unit	Note / Test Condition
		Min.	Typ.	Max.		
Turn-on delay time	$T_{d(on)}$	—	76.0	—	ns	$V_{cc}=400V, I_c=75A,$ $R_{on}=10\ \Omega, R_{off}=10\ \Omega,$ $C_{ge}=0nF, V_{GE}=0/15V,$ $L_{load}=60\mu H, T_{vj}=25^\circ C$
Rise time	T_r	—	115	—	ns	
Turn-off delay time	$T_{d(off)}$	—	196	—	ns	
Fall time	t_f	—	79.0	—	ns	
Turn-on energy	E_{on}	—	3.08	—	mJ	
Turn-off energy	E_{off}	—	2.22	—	mJ	
Total switch energy	E_{total}	—	5.30	—	mJ	

Parameter	Symbol	Values			Unit	Note / Test Condition
		Min.	Typ.	Max.		
Turn-on delay time	$T_{d(on)}$	—	71.0	—	ns	$V_{cc}=400V, I_c=75A,$ $R_{on}=10\ \Omega, R_{off}=10\ \Omega,$ $C_{ge}=0nF, V_{GE}=0/15V,$ $L_{load}=60\mu H, T_{vj}=150^\circ C$
Rise time	T_r	—	120	—	ns	
Turn-off delay time	$T_{d(off)}$	—	211	—	ns	
Fall time	t_f	—	82.0	—	ns	
Turn-on energy	E_{on}	—	5.21	—	mJ	
Turn-off energy	E_{off}	—	2.57	—	mJ	
Total switch energy	E_{total}	—	7.78	—	mJ	

Table 7 Diode characteristics

Parameter	Symbol	Values			Unit	Note / Test Condition
		Min.	Typ.	Max.		
Reverse recovery energy	E _{rec}	—	301	—	uJ	I _F =75A, V _R =400V, V _{GE} =0/15V, R _{ON} =10 Ω, T _{vj} =25°C
Diode reverse recovery time	t _{rr}	—	207	—	nS	
Diode reverse recovery charge	Q _{rr}	—	1355	—	nC	
Diode peak reverse recovery current	I _{rrm}	—	18.6	—	A	
Diode peak rate of fall of reverse Recovery current during t _{rr}	d _{irr} /dt	—	119	—	A/uS	
Parameter	Symbol	Values			Unit	
		Min.	Typ.	Max.		
Reverse recovery energy	E _{rec}	—	991	—	uJ	I _F =75A, V _R =400V, V _{GE} =0/15V, R _{ON} =10 Ω, T _{vj} =150°C
Diode reverse recovery time	t _{rr}	—	323	—	nS	
Diode reverse recovery charge	Q _{rr}	—	4812	—	nC	
Diode peak reverse recovery current	I _{rrm}	—	34.7	—	A	
Diode peak rate of fall of reverse Recovery current during t _{rr}	d _{irr} /dt	—	184	—	A/uS	

4 Electrical characteristics diagram

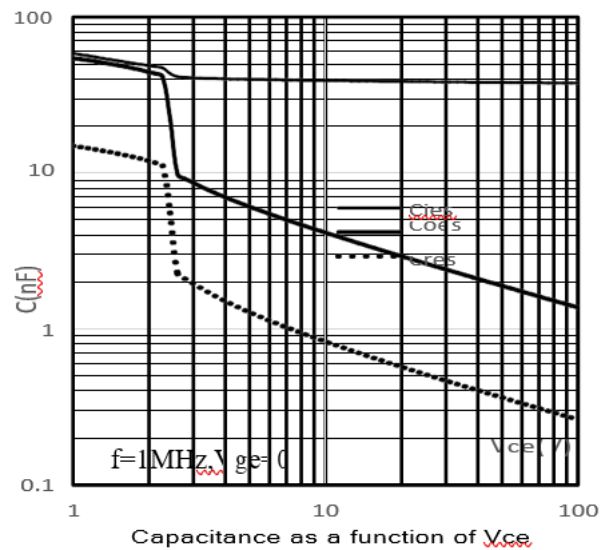
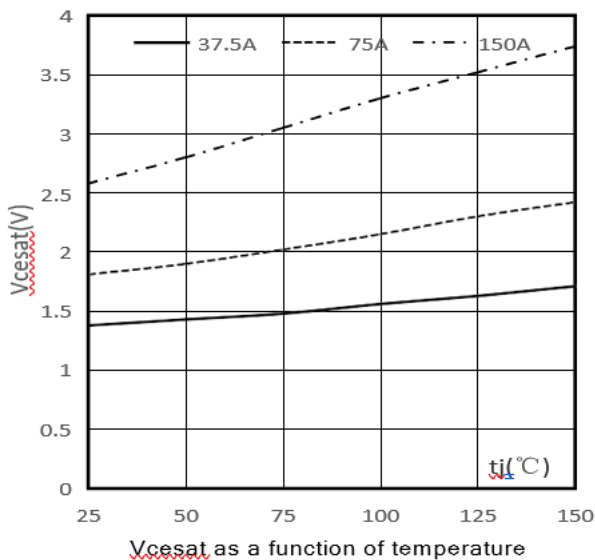
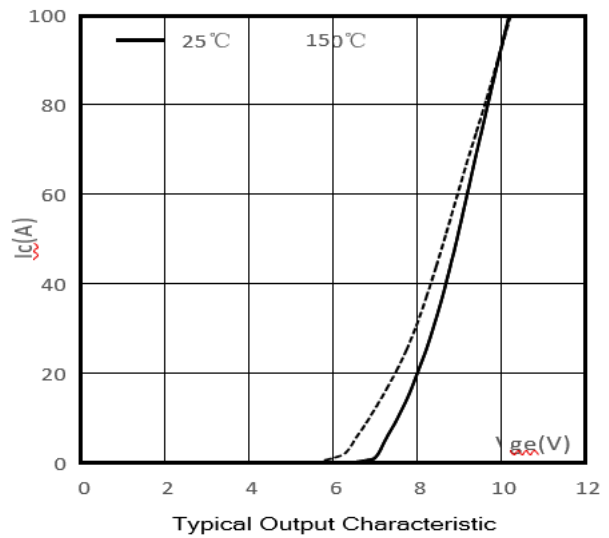
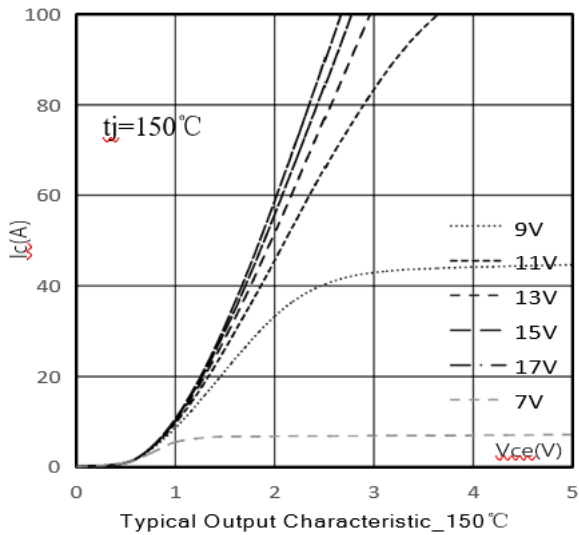
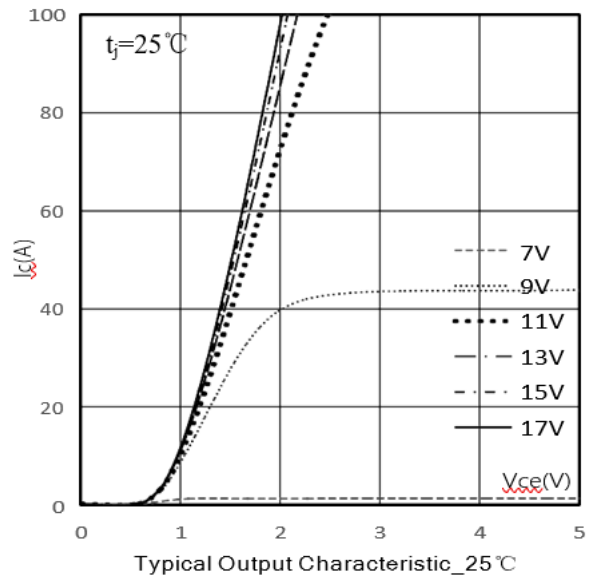
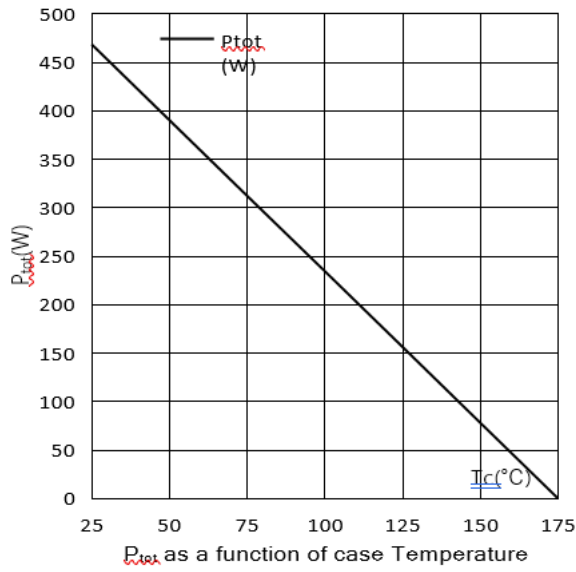

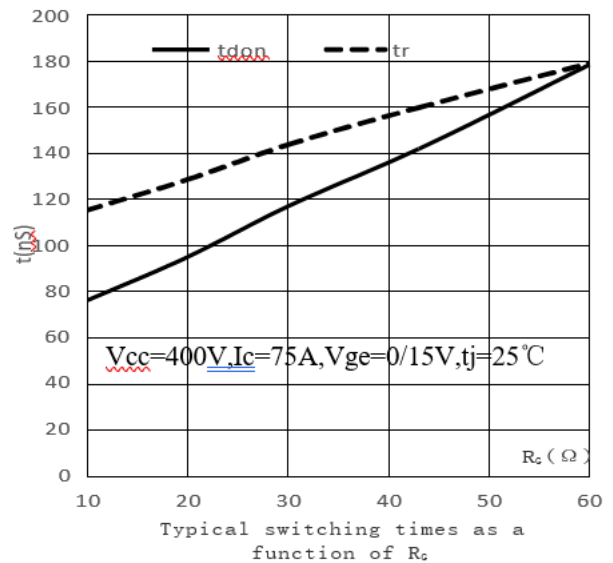
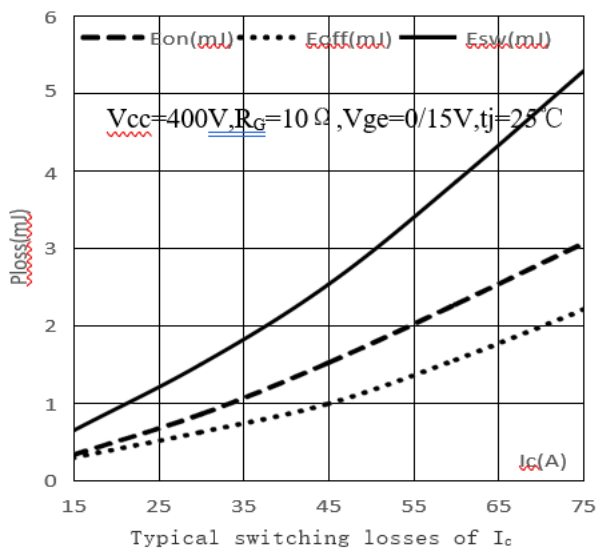
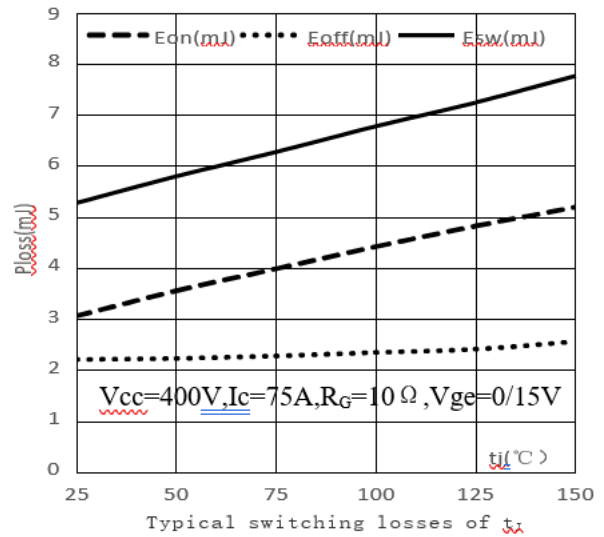
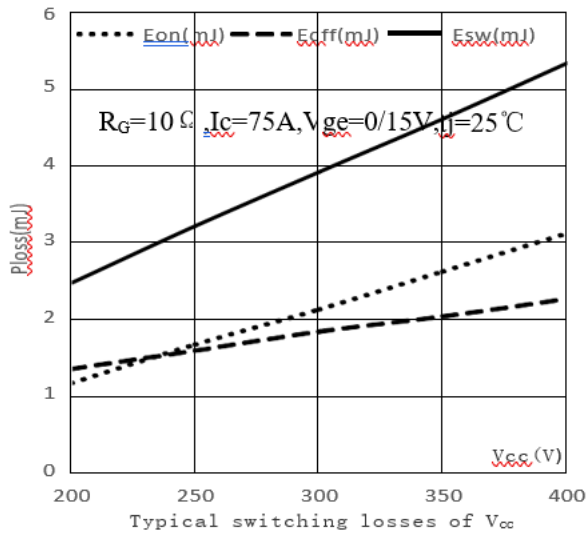
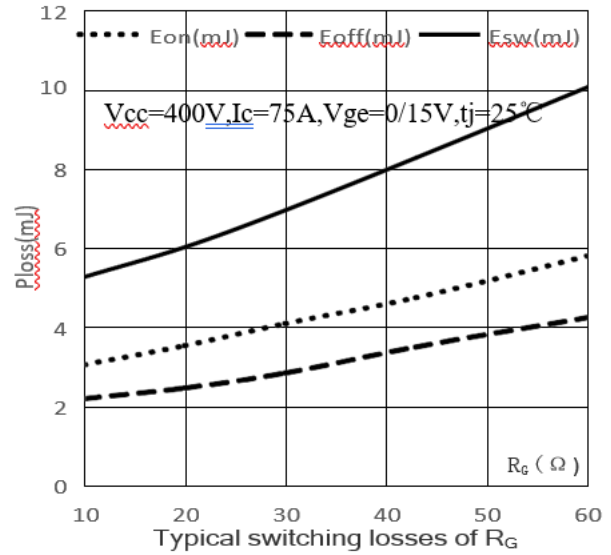
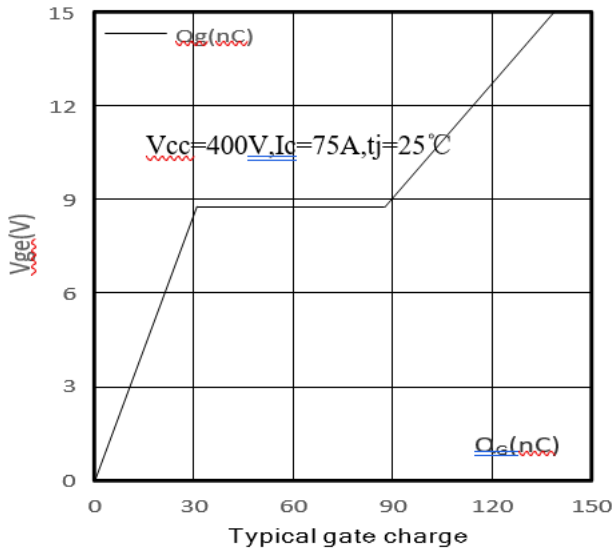

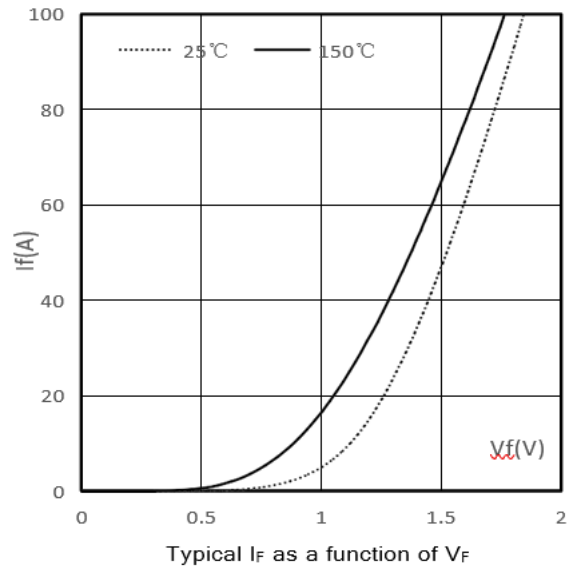
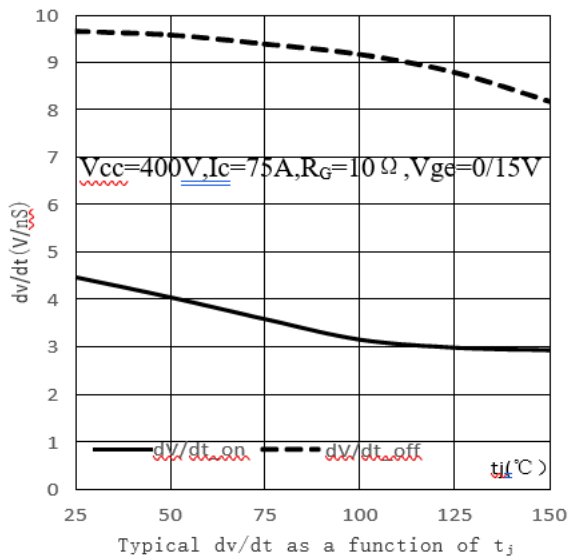
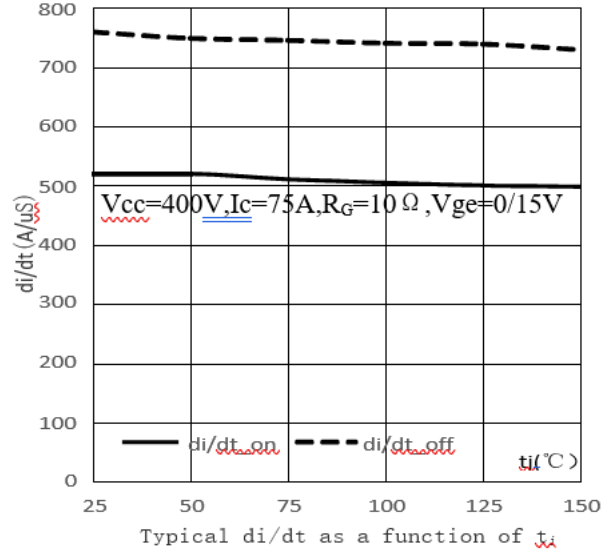
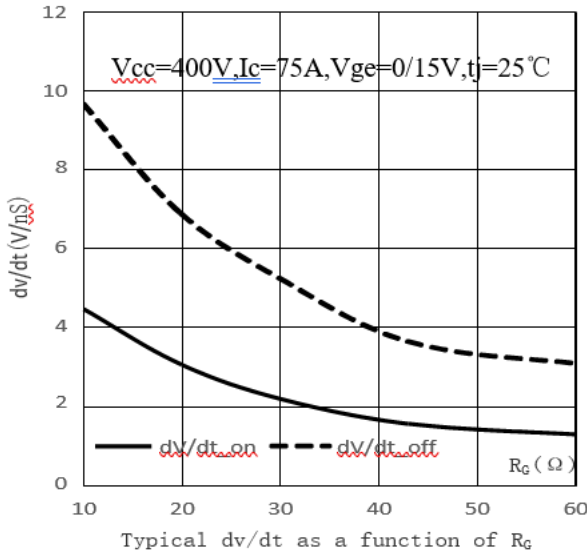
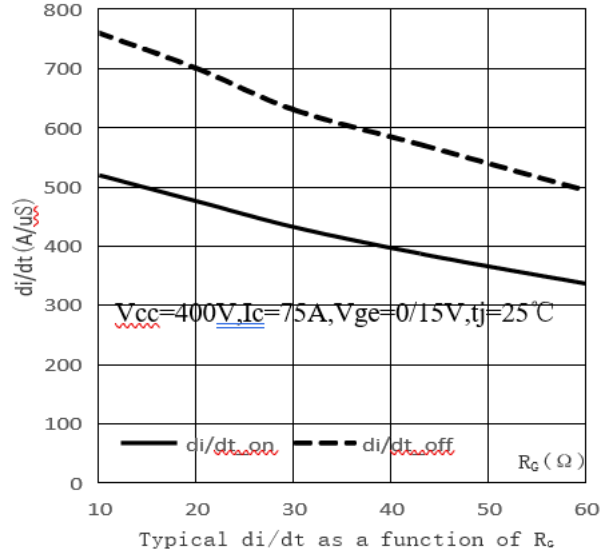
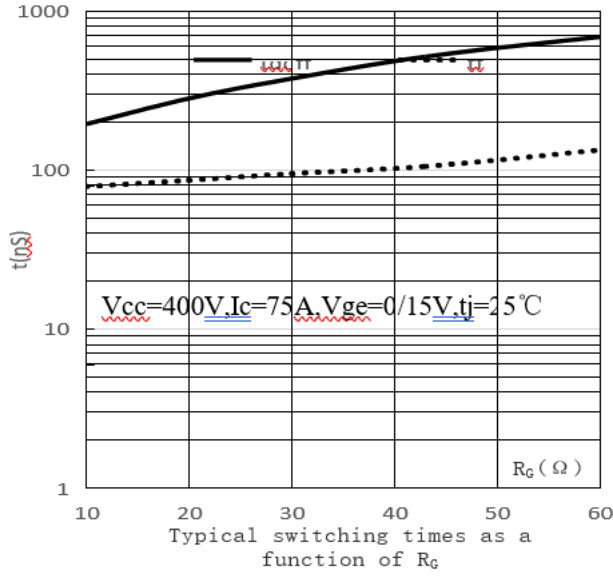

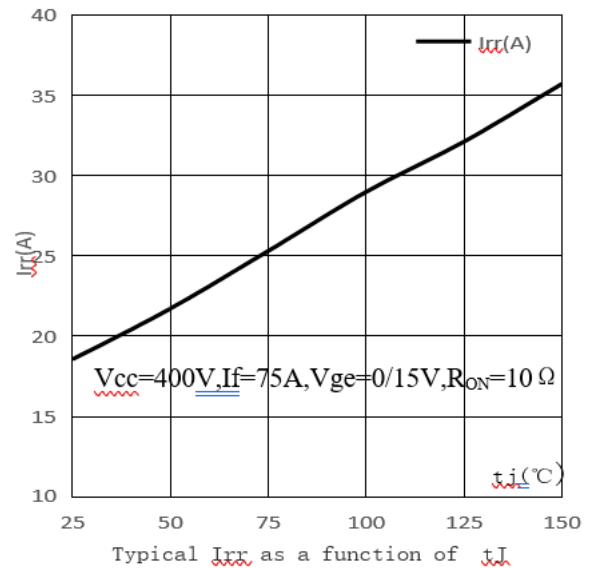
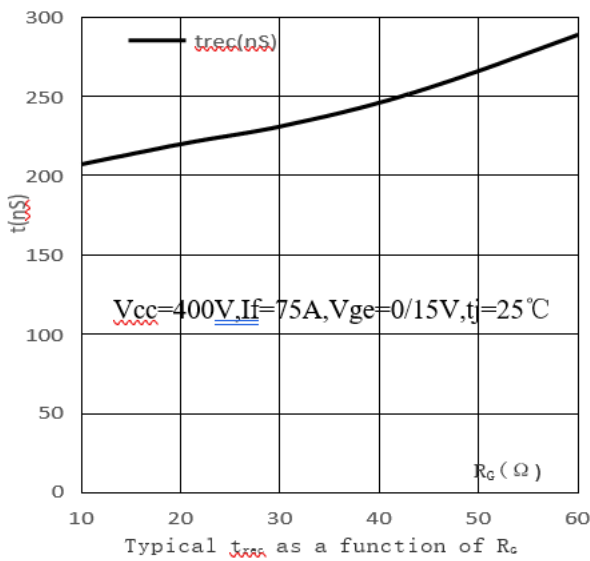
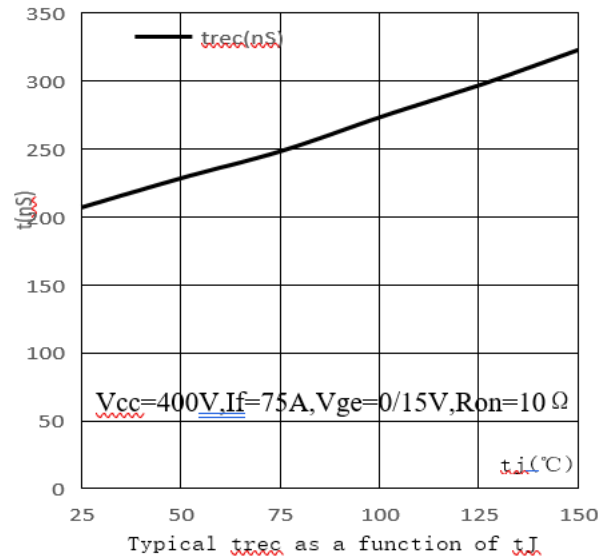
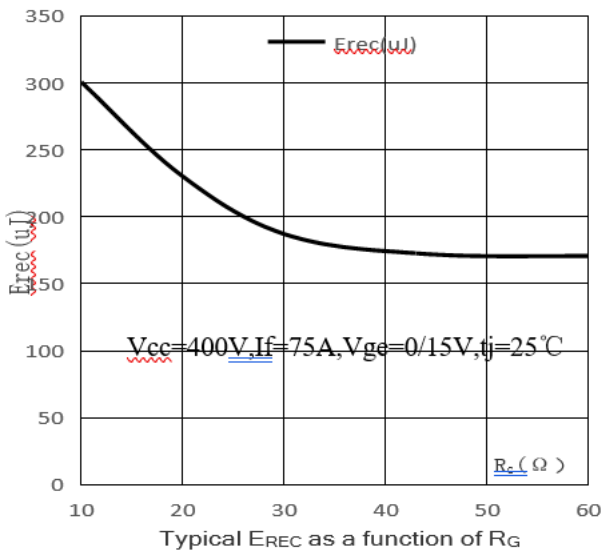
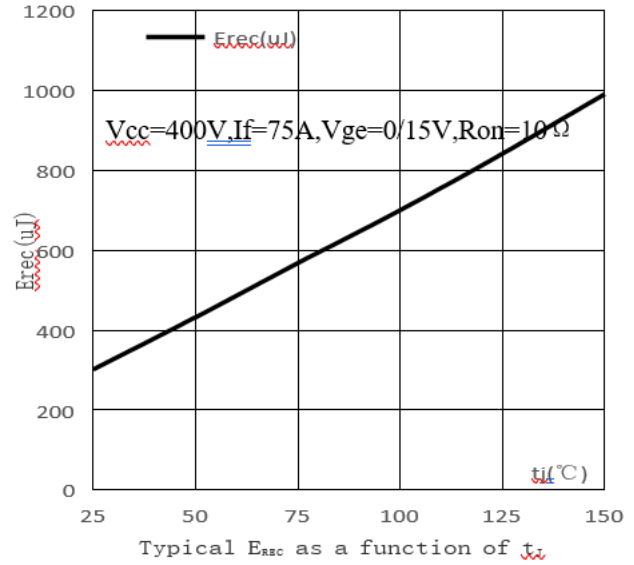
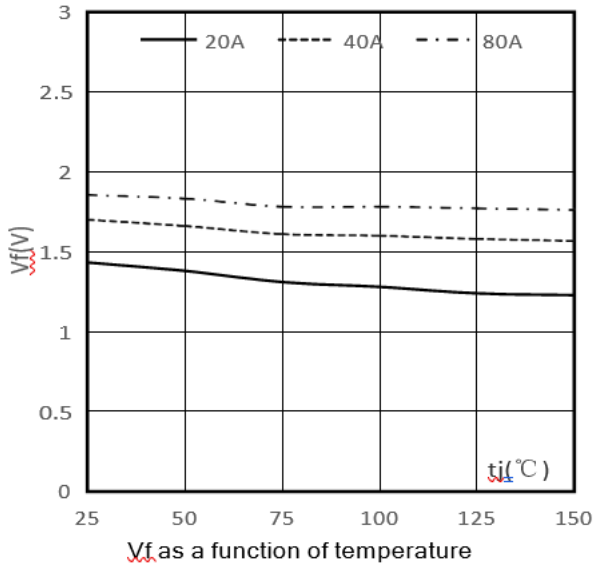

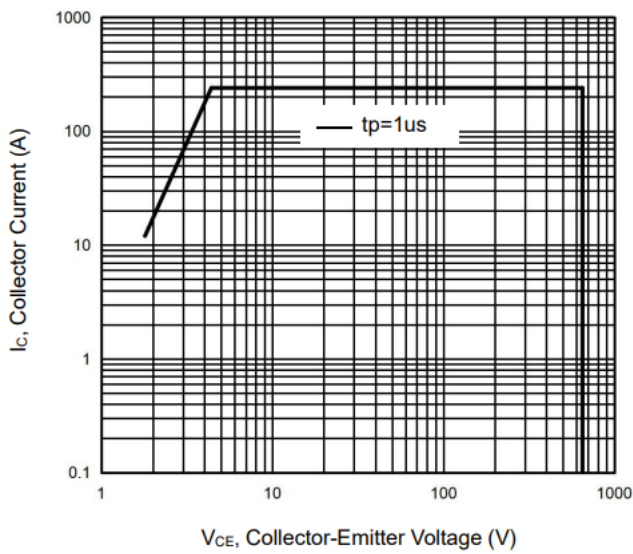
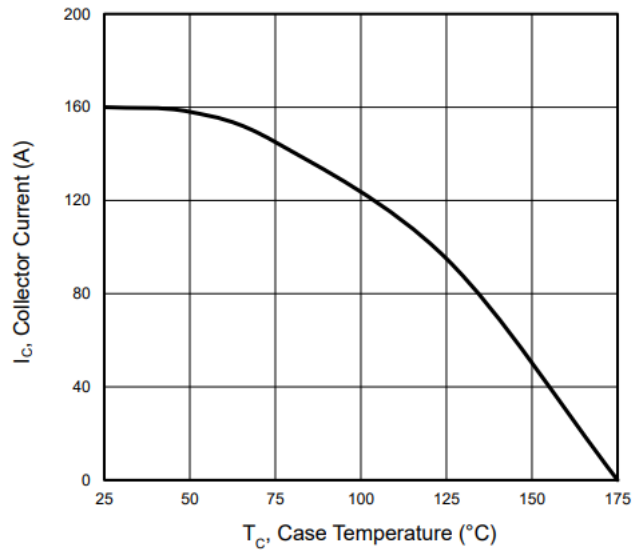
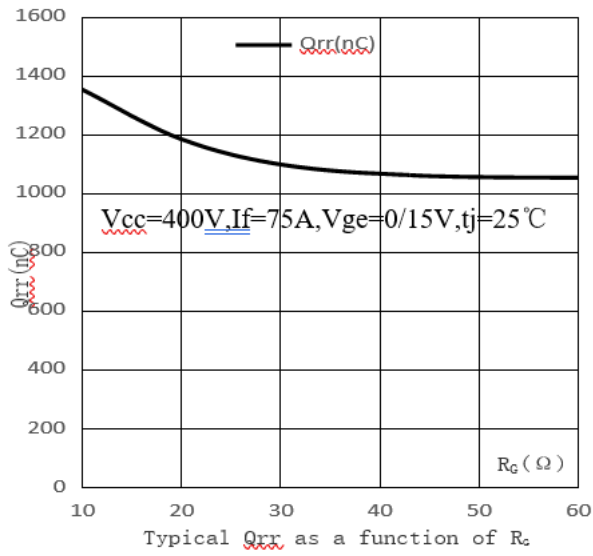
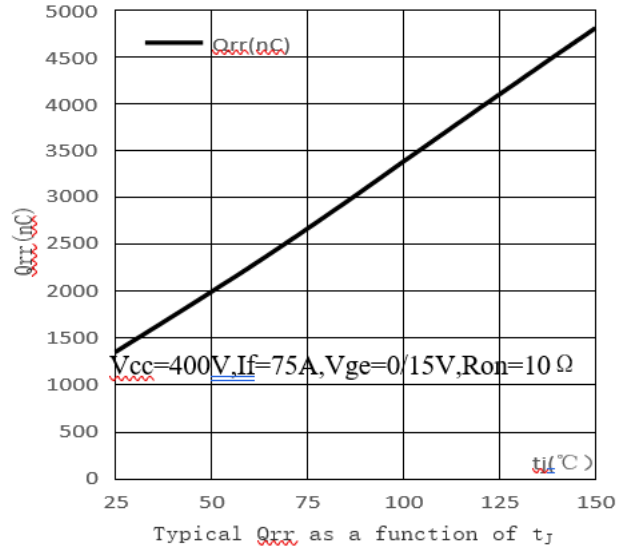
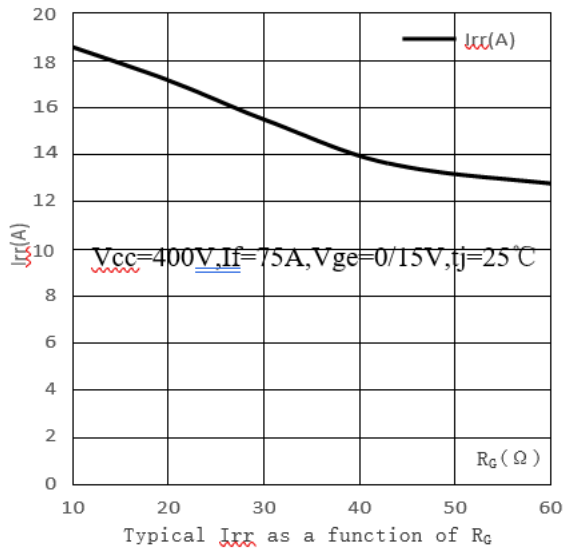

5 Test Circuits

1) Gate Charge Test Circuit

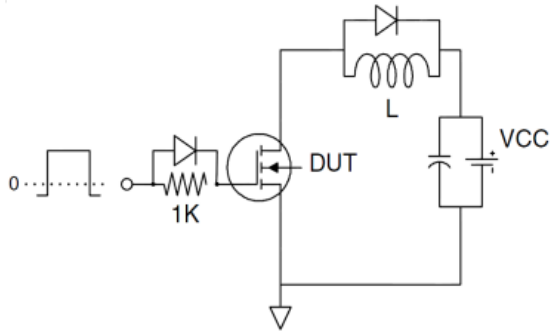

2) Switch Time Test Circuit

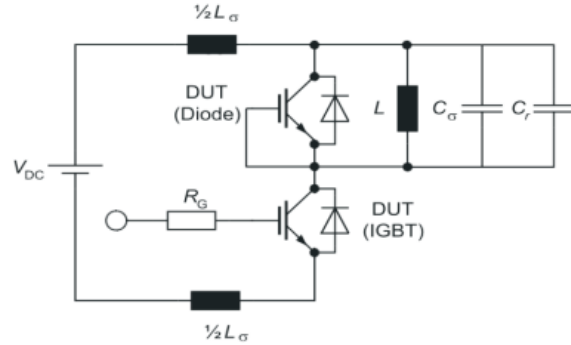

Switching characteristics

1) definition of switching times

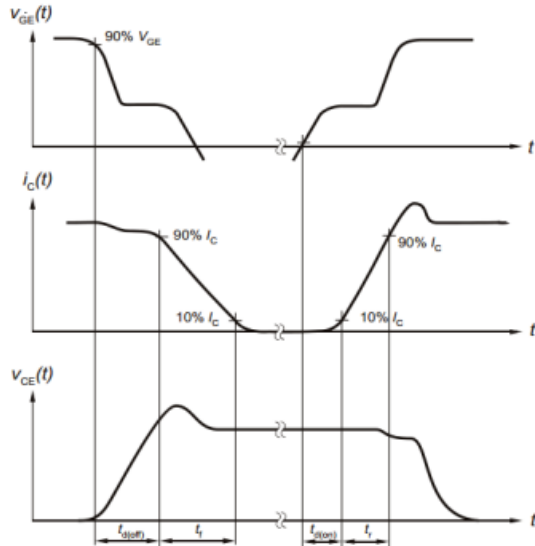

2) definition of switching losses

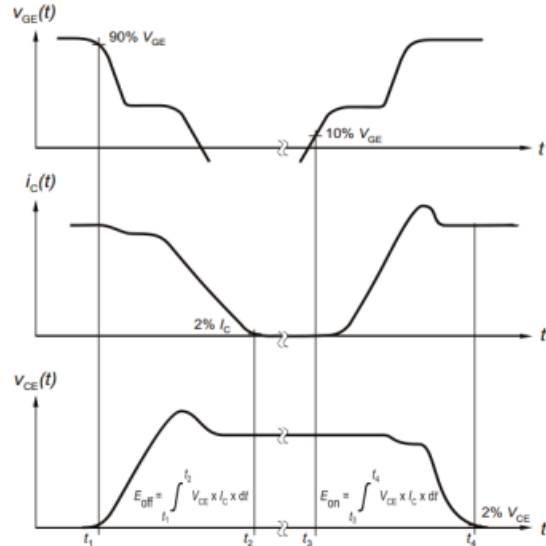

3) Definition of diode switching characteristics

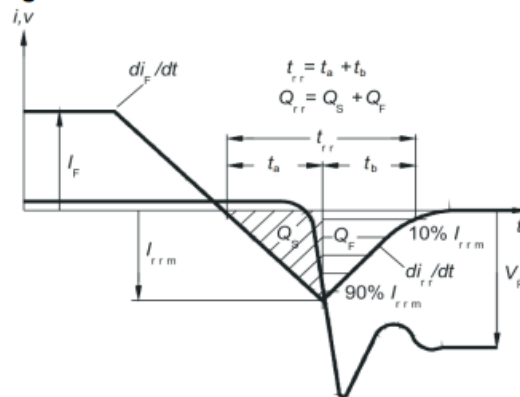

6 Package Outlines

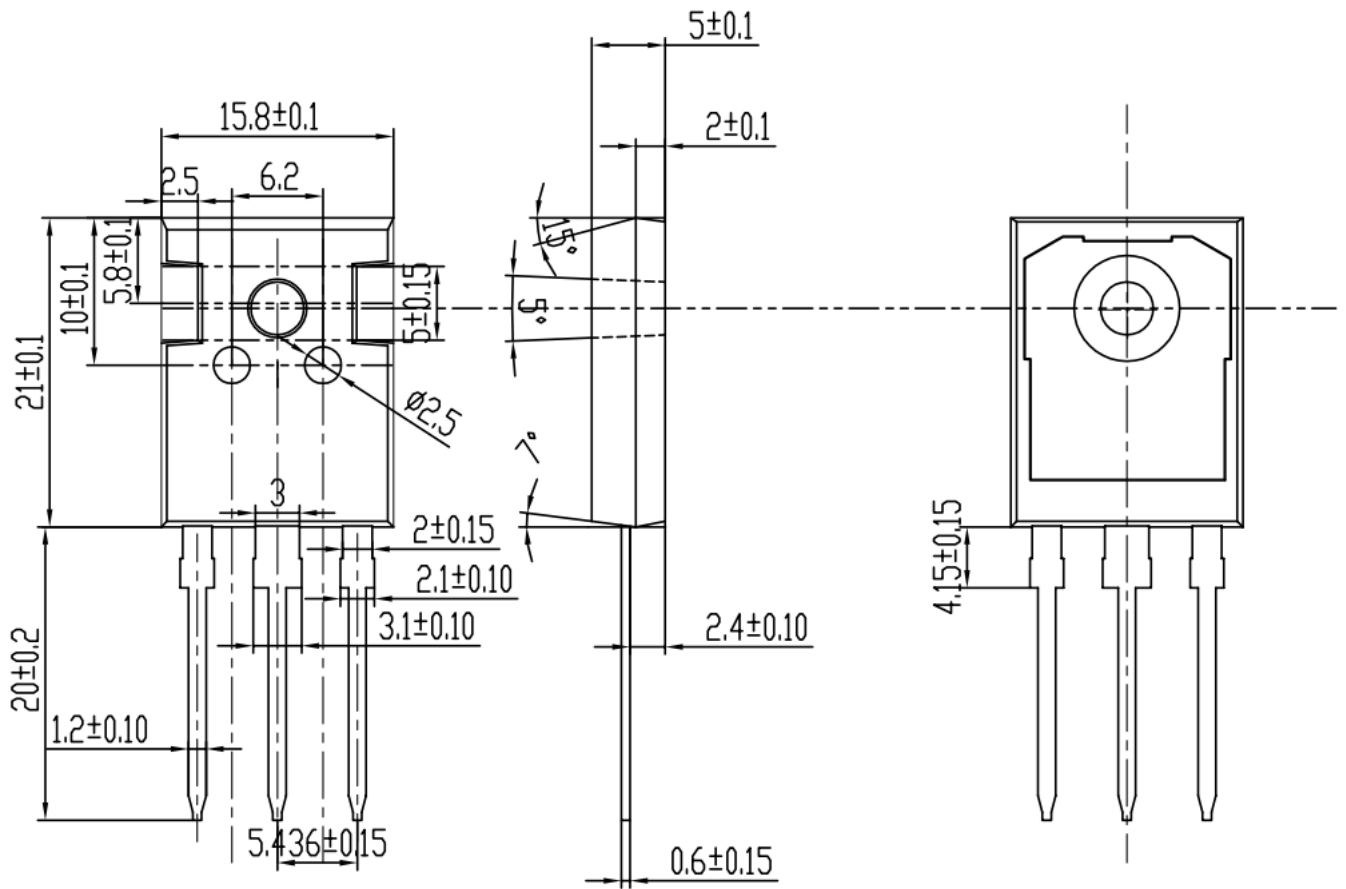

Outline PG-TO247(HT)

Revision History

Revision	Date	Subjects (major changes since last revision)
1.0	2023-02-28	Preliminary version

X-ON Electronics

Largest Supplier of Electrical and Electronic Components

Click to view similar products for [ANHI manufacturer](#):

Other Similar products are found below :

[ADP120N080G2](#) [ADQ120N040BH](#) [ADQ120N040G2](#) [ADQ120N080G2](#) [ADR065N028AH](#) [ADW120N040BH](#) [AGW60N65](#) [AGW75N65](#)
[ASA50R130E](#) [ASA60R090EFDA](#) [ASA60R150E](#) [ASA60R170E](#) [ASA60R180EFD](#) [ASA60R210E](#) [ASA60R280E](#) [ASA60R330E](#)
[ASA65R120EFD](#) [ASA65R220E](#) [ASA65R270E](#) [ASA65R300E](#) [ASA65R350E](#) [ASA65R550E](#) [ASA65R850E](#) [ASA70R240E](#) [ASA70R380E](#)
[ASA70R600E](#) [ASA80R290E](#) [ASA80R900E](#) [ASB60R150E](#) [ASB65R120EFD](#) [ASB65R220E](#) [ASB65R300E](#) [ASB70R380E](#) [ASB80R750E](#)
[ASD65R350E](#) [ASD65R550E](#) [ASD65R850E](#) [ASD70R380E](#) [ASD70R600E](#) [ASD80R750E](#) [ASE70R950E](#) [ASM60R330E](#) [ASM65R265E](#)
[ASM65R280E](#) [ASR65R046EFD](#) [ASR65R120EFD](#) [ASW50R130E](#) [ASW60R029EFD](#) [ASW60R090EFD](#) [ASW60R150E](#)