

## MOSFET Silicon N-Channel MOS

### 1. Applications

Single-ended flyback or two-transistor forward topologies.  
PC power, PD Adaptor, LCD & PDP TV and LED lighting.



### 2. Features

Low drain-source on-resistance:  $R_{DS(ON)} = 0.250\Omega$  (typ.)  
Easy to control Gate switching  
Enhancement mode:  $V_{th} = 2.8$  to  $4.2$  V

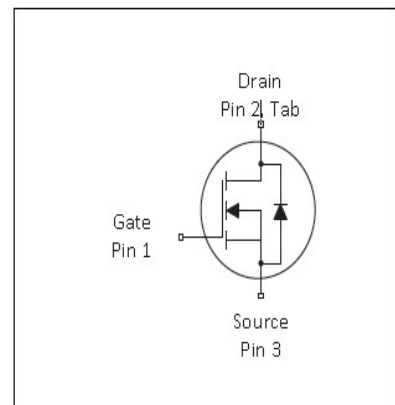
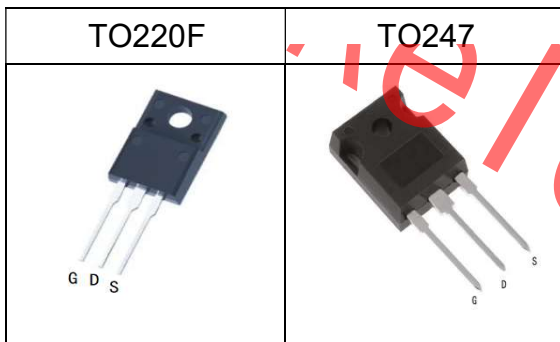

**Table 1 Key Performance Parameters**

Parameter	Value	Unit
$V_{DS} @ T_{j,max}$	800	V
$R_{DS(on),max}$	290	m $\Omega$
$Q_{g,typ}$	38.8	nC
$I_{D,pulse}$	45	A

### 3. Packaging and Internal Circuit

Part Name	Package	Marking
ASA80R290E	TO220F	ASA80R290E
ASW80R290E	TO247	ASW80R290E



**1 Maximum ratings**  
at  $T_j = 25^\circ\text{C}$ , unless otherwise specified

**Table 2 Maximum ratings**

Parameter	Symbol	Values			Unit	Note / Test Condition
		Min.	Typ.	Max.		
Continuous drain current <sup>1)</sup>	$I_D$		-	15	A	$T_C = 25^\circ\text{C}$
Pulsed drain current <sup>2)</sup>	$I_{D,pulse}$	-	-	45	A	$T_C = 25^\circ\text{C}$
Avalanche energy, single pulse	$E_{AS}$	-	-	500	mJ	
MOSFET dv/dt ruggedness	dv/dt	-	-	121	V/ns	$V_{DS} = 0 \dots 400\text{V}$
Gate source voltage (static)	$V_{GS}$	-20	-	20	V	static;
Gate source voltage (dynamic)	$V_{GS}$	-30	-	30	V	AC ( $f > 1\text{ Hz}$ )
Power dissipation	$P_{tot}$	-	-	227	W	$T_C = 25^\circ\text{C}$
Storage temperature	$T_{stg}$	-55	-	150	$^\circ\text{C}$	
Operating junction temperature	$T_j$	-55	-	150	$^\circ\text{C}$	
Reverse diode dv/dt <sup>3)</sup>	dv/dt	-	-	15	V/ns	$V_{DS} = 0 \dots 400\text{V}$ , $I_{SD} \leq 48\text{A}$ , $T_j = 25^\circ\text{C}$ see table 8

<sup>1)</sup> Limited by  $T_{j,max}$ . Maximum Duty Cycle  $D = 0.50$

<sup>2)</sup> Pulse width  $t_p$  limited by  $T_{j,max}$

<sup>3)</sup> Identical low side and high side switch with identical  $R_G$

Not for release

## 2 Thermal characteristics

**Table 3 Thermal characteristics (TO220F)**

Parameter	Symbol	Values			Unit	Note / Test Condition
		Min.	Typ.	Max.		
Thermal resistance, junction - case	$R_{thJC}$	-	-	3.6	°C/W	-
Thermal resistance, junction - ambient	$R_{thJA}$	-	-	62	°C/W	device on PCB, minimal footprint

**Thermal characteristics (TO247)**

Parameter	Symbol	Values			Unit	Note / Test Condition
		Min.	Typ.	Max.		
Thermal resistance, junction - case	$R_{thJC}$	-	-	0.55	°C/W	-
Thermal resistance, junction - ambient	$R_{thJA}$	-	-	62	°C/W	device on PCB, minimal footprint

release

### 3 Electrical characteristics

at  $T_j=25^{\circ}\text{C}$ , unless otherwise specified

**Table 4 Static characteristics**

Parameter	Symbol	Values			Unit	Note / Test Condition
		Min.	Typ.	Max.		
Drain-source breakdown voltage	$V_{(BR)DSS}$	805	-	-	V	$V_{GS}=0\text{V}$ , $I_D=10\text{mA}$
Gate threshold voltage	$V_{(GS)th}$	2.8		4.2	V	$V_{DS}=V_{GS}$ , $I_D=250\mu\text{A}$
Zero gate voltage drain current	$I_{DSS}$	-	-	1	$\mu\text{A}$	$V_{DS}=800\text{V}$ , $V_{GS}=0\text{V}$ , $T_j=25^{\circ}\text{C}$
Gate-source leakage current	$I_{GSS}$	-	-	100	nA	$V_{GS}=30\text{V}$ , $V_{DS}=0\text{V}$
Drain-source on-state resistance	$R_{DS(on)}$	-	0.250	0.290	$\Omega$	$V_{GS}=10\text{V}$ , $I_D=7.2\text{A}$ , $T_j=25^{\circ}\text{C}$
Gate resistance (Intrinsic)	$R_G$	-	25	-	$\Omega$	$f=1\text{MHz}$ , open drain

**Table 5 Dynamic characteristics**

Parameter	Symbol	Values			Unit	Note / Test Condition
		Min.	Typ.	Max.		
Input capacitance	$C_{iss}$	-	1728	-	pF	$V_{GS}=0\text{V}$ , $V_{DS}=100\text{V}$ , $f=100\text{kHz}$
Output capacitance	$C_{oss}$	-	46	-	pF	$V_{GS}=0\text{V}$ , $V_{DS}=100\text{V}$ , $f=100\text{kHz}$
Reverse transfer capacitance	$C_{rss}$	-	0.78	-	pF	$V_{GS}=0\text{V}$ , $V_{DS}=100\text{V}$ , $f=100\text{kHz}$
Turn-on delay time	$t_{d(on)}$	-	29	-	ns	$V_{DD}=400\text{V}$ , $V_{GS}=10\text{V}$ , $I_D=17\text{A}$ , $R_G=5\Omega$ ; see table 9
Rise time	$t_r$	-	42	-	ns	$V_{DD}=400\text{V}$ , $V_{GS}=10\text{V}$ , $I_D=17\text{A}$ , $R_G=5\Omega$ ; see table 9
Turn-off delay time	$t_{d(off)}$	-	137	-	ns	$V_{DD}=400\text{V}$ , $V_{GS}=10\text{V}$ , $I_D=17\text{A}$ , $R_G=5\Omega$ ; see table 9
Fall time	$t_f$	-	36	-	ns	$V_{DD}=400\text{V}$ , $V_{GS}=10\text{V}$ , $I_D=17\text{A}$ , $R_G=5\Omega$ ; see table 9

**Table 6 Gate charge characteristics**

Parameter	Symbol	Values			Unit	Note / Test Condition
		Min.	Typ.	Max.		
Gate to source charge	$Q_{gs}$	-	8.6	-	nC	$V_{DD}=600\text{V}$ , $I_D=17\text{A}$ , $V_{GS}=0$ to $10\text{V}$
Gate to drain charge	$Q_{gd}$	-	13.4	-	nC	$V_{DD}=600\text{V}$ , $I_D=17\text{A}$ , $V_{GS}=0$ to $10\text{V}$
Gate charge total	$Q_g$	-	38.8	-	nC	$V_{DD}=600\text{V}$ , $I_D=17\text{A}$ , $V_{GS}=0$ to $10\text{V}$
Gate plateau voltage	$V_{plateau}$	-	5	-	V	$V_{DD}=600\text{V}$ , $I_D=17\text{A}$ , $V_{GS}=0$ to $10\text{V}$

**Table 7 Reverse diode characteristics**

Parameter	Symbol	Values			Unit	Note / Test Condition
		Min.	Typ.	Max.		
Diode forward voltage	$V_{SD}$	-	0.7	-	V	$V_{GS}=0V, I_F=1A, T_j=25^{\circ}C$
Reverse recovery time	$t_{rr}$	-	427	-	ns	$V_R=400V, I_F=17A, di_F/dt=100A/\mu s$ ; see table 8
Reverse recovery charge	$Q_{rr}$	-	6.8	-	uC	$V_R=400V, I_F=17A, di_F/dt=100A/\mu s$ ; see table 8
Peak reverse recovery current	$I_{rrm}$	-	29	-	A	$V_R=400V, I_F=17A, di_F/dt=100A/\mu s$ ; see table 8

release

## 4 Test Circuits

**Table 8 Diode characteristics**

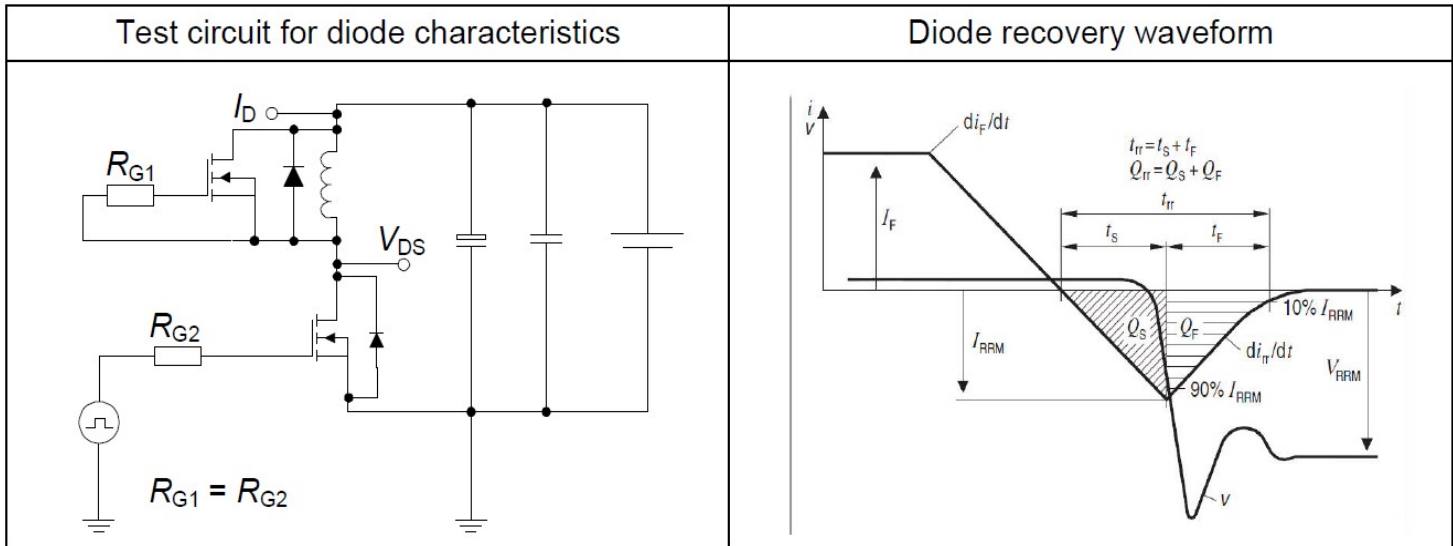

**Table 9 Switching times**

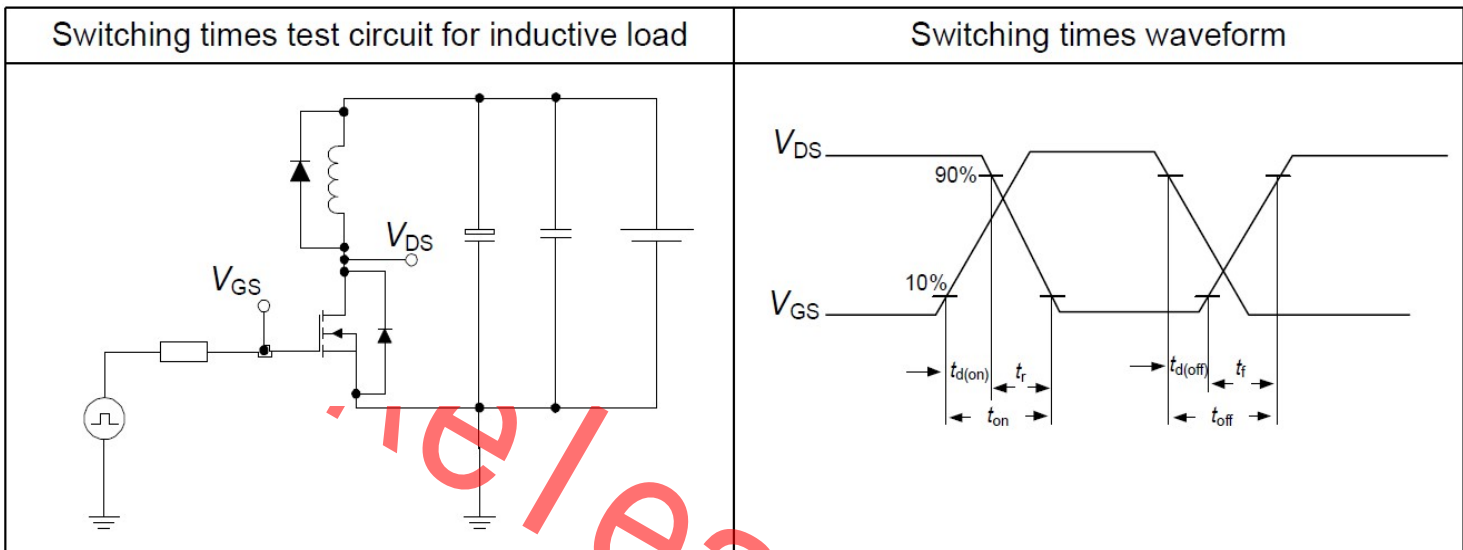

**Table 10 Unclamped inductive load**

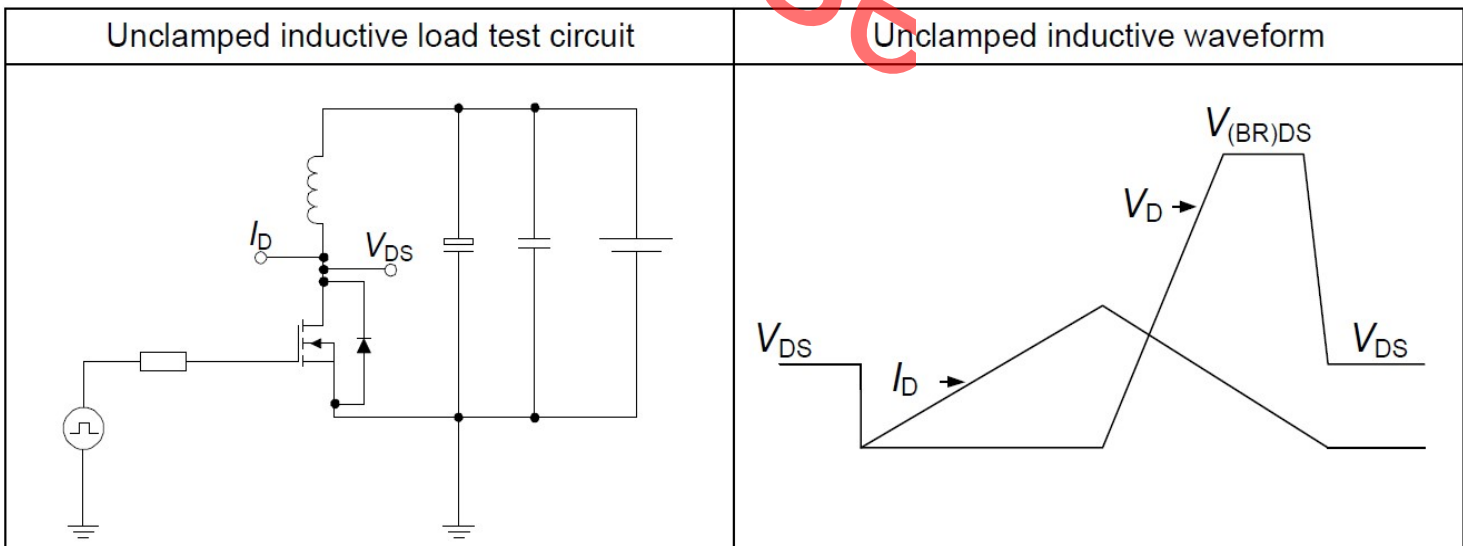

### 5 Package Outlines

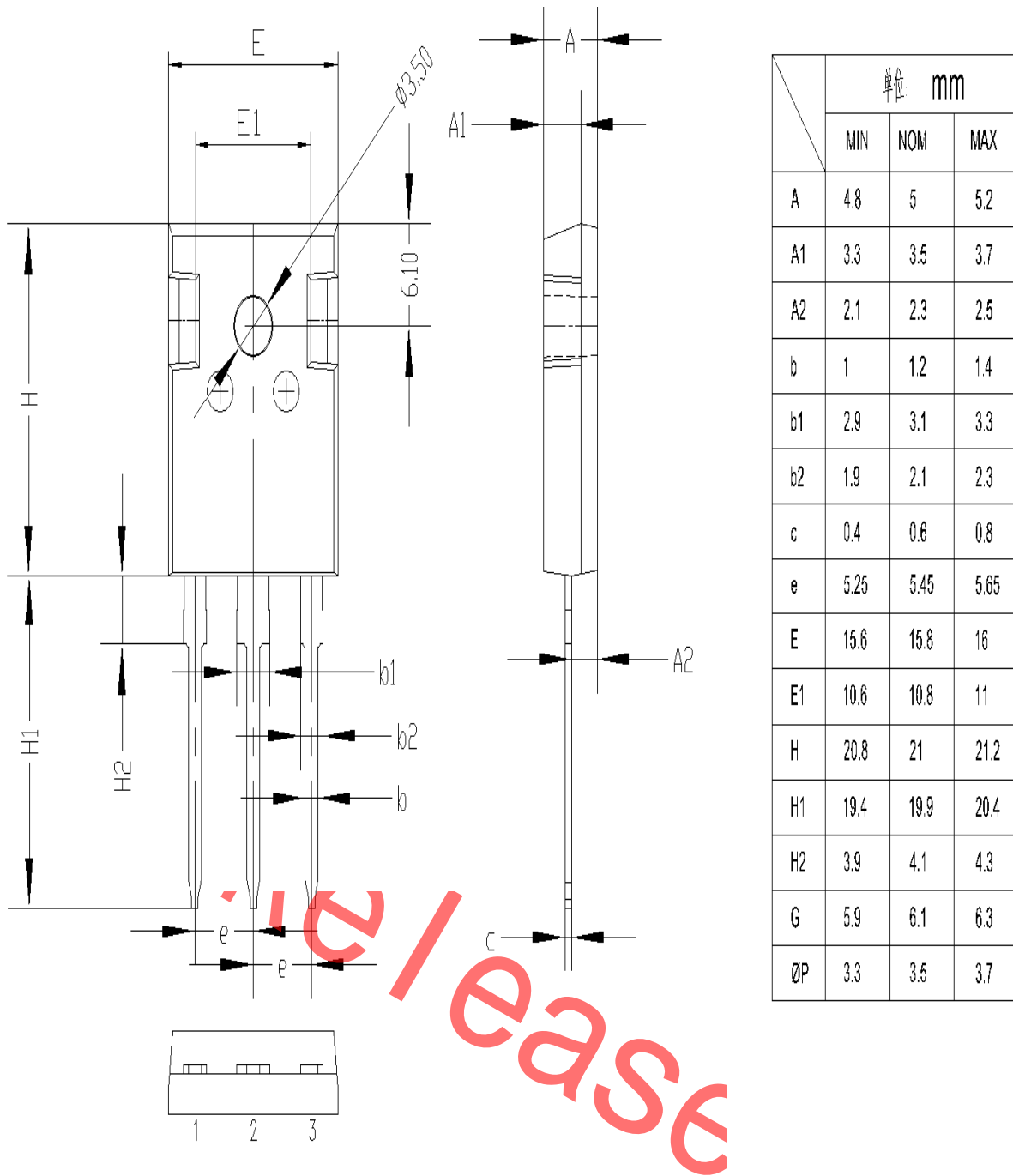

Figure1: Outline PG-T0247

TO-220F

单位: mm

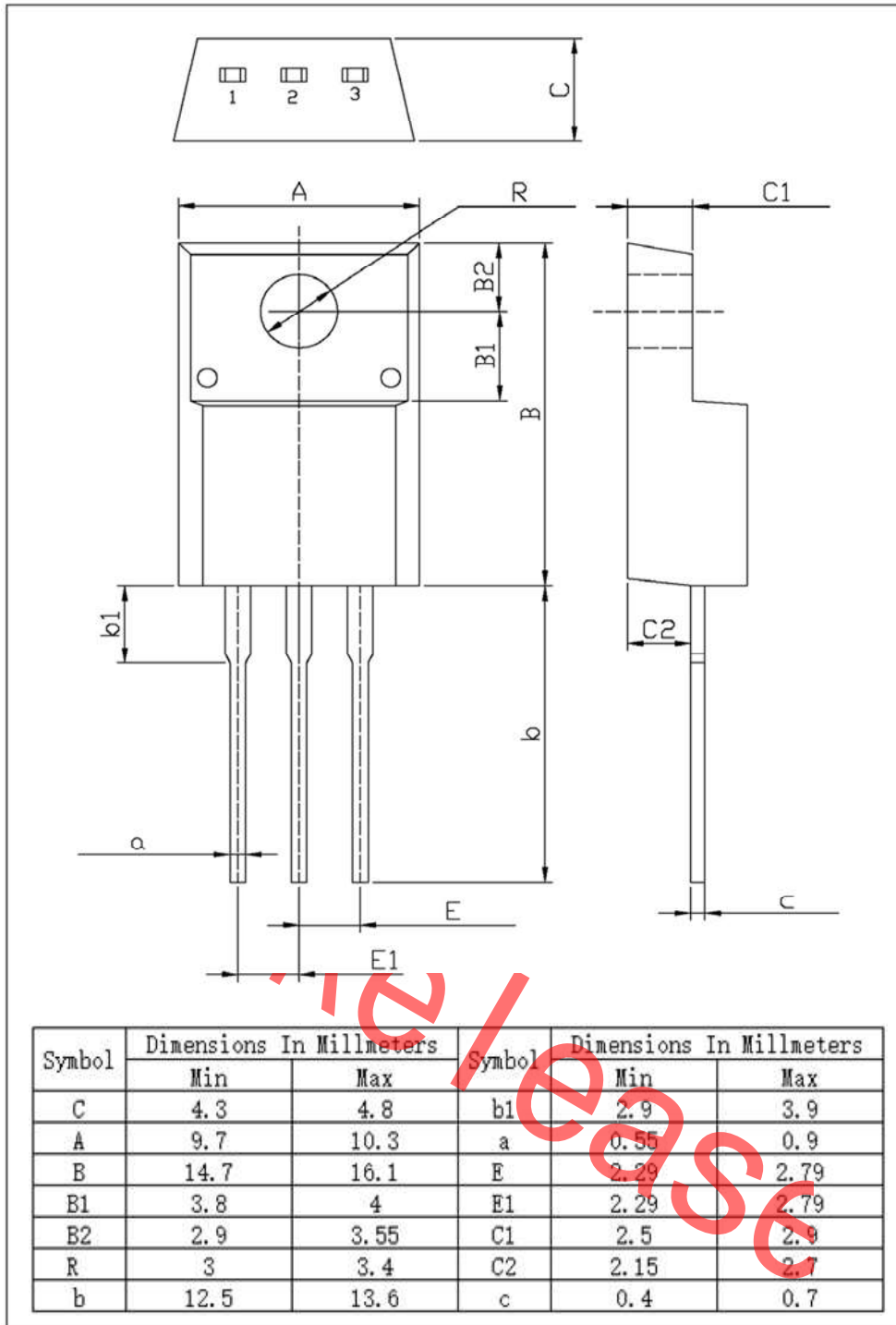

Figure2: Outline PG-TO220F



## Revision History

Revision	Date	Subjects (major changes since last revision)
1.0	2021-03-15	Preliminary version

Not for release

## X-ON Electronics

Largest Supplier of Electrical and Electronic Components

*Click to view similar products for [MOSFET](#) category:*

*Click to view products by [ANHI](#) manufacturer:*

Other Similar products are found below :

[IRFD120](#) [IRFY240C](#) [JANTX2N5237](#) [BUK455-60A/B](#) [MIC4420CM-TR](#) [VN1206L](#) [NDP4060](#) [SI4482DY](#) [IPS70R2K0CEAKMA1](#)  
[SQD23N06-31L-GE3](#) [TK16J60W,S1VQ\(O](#) [2SK2614\(TE16L1,Q\)](#) [DMN1017UCP3-7](#) [EFC2J004NUZTDG](#) [DMN1053UCP4-7](#) [SQJ469EP-](#)  
[T1-GE3](#) [NTE2384](#) [DMC2700UDMQ-7](#) [DMN2080UCB4-7](#) [DMN61D9UWQ-13](#) [US6M2GTR](#) [DMN31D5UDJ-7](#) [DMP22D4UFO-7B](#)  
[DMN1006UCA6-7](#) [DMN16M9UCA6-7](#) [STF5N65M6](#) [IRF40H233XTMA1](#) [STU5N65M6](#) [DMN6022SSD-13](#) [DMN13M9UCA6-7](#)  
[DMTH10H4M6SPS-13](#) [DMN2990UFB-7B](#) [IPB80P04P405ATMA2](#) [2N7002W-G](#) [MCAC30N06Y-TP](#) [MCQ7328-TP](#) [NTMC083NP10M5L](#)  
[NVMFS2D3P04M8LT1G](#) [BXP7N65D](#) [BXP4N65F](#) [AOL1454G](#) [WMJ80N60C4](#) [BXP2N20L](#) [BXP2N65D](#) [BXT1150N10J](#) [BXT1700P06M](#)  
[TSM60NB380CP](#) [ROG](#) [RQ7L055BGTCR](#) [DMNH15H110SK3-13](#) [SLF10N65ABV2](#)