

## MOSFET Silicon N-Channel MOS

### 1. Applications

Boost PFC switch, single-ended flyback or two-transistor forward, Half bridge or Asymmetric half bridge or Series resonance half bridge topologies. PC power, Adaptor, LCD & PDP TV, LED Lighting, Server power, Telecom power, and UPS Application.



### 2. Features

Low drain-source on-resistance:  $R_{DS(ON)} = 0.120\Omega$  (typ.)  
 Easy to control Gate switching  
 Enhancement mode:  $V_{th} = 2.8$  to  $4.2$  V

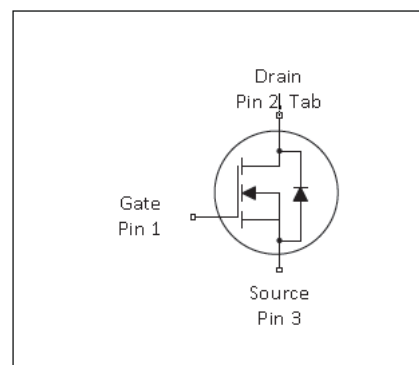
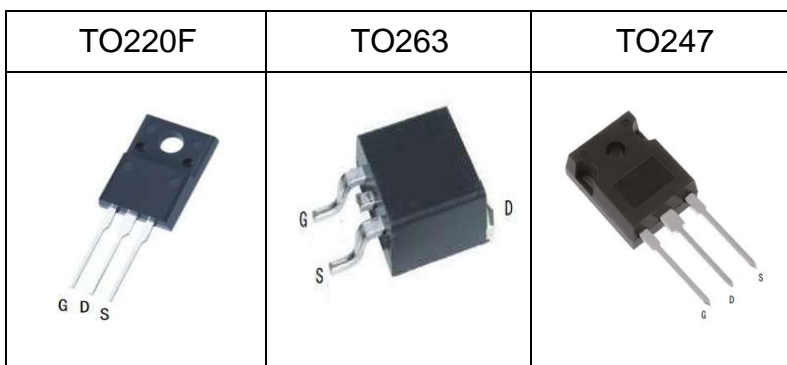


**Table 1 Key Performance Parameters**

Parameter	Value	Unit
$V_{DS} @ T_{j,max}$	650	V
$R_{DS(on),max}$	150	m $\Omega$
$Q_{g,typ}$	47.6	nC
$I_{D,pulse}$	84	A

### 3. Packaging and Internal Circuit

Part Name	Package	Marking
ASA60R150E	TO220F	ASA60R150E
ASW60R150E	TO247	ASW60R150E
ASB60R150E	TO263	ASB60R150E



## 1 Maximum ratings

at  $T_j = 25^\circ\text{C}$ , unless otherwise specified

**Table 2 Maximum ratings**

Parameter	Symbol	Values			Unit	Note / Test Condition
		Min.	Typ.	Max.		
Continuous drain current <sup>1)</sup>	$I_D$		-	28	A	$T_C=25^\circ\text{C}$
Pulsed drain current <sup>2)</sup>	$I_{D,pulse}$	-	-	84	A	$T_C=25^\circ\text{C}$
Avalanche energy, single pulse	$E_{AS}$	-	-	605	mJ	$T_C=25^\circ\text{C}, V_{DD}=50\text{V}, L=10\text{mH}, R_G=25\Omega$
Avalanche current, single pulse	$I_{AR}$	-	-	11	A	$T_C=25^\circ\text{C}, V_{DD}=50\text{V}, L=10\text{mH}, R_G=25\Omega$
MOSFET dv/dt ruggedness	dv/dt	-	-	130	V/ns	$V_{DS}=0\dots400\text{V}$
Gate source voltage (static)	$V_{GS}$	-20	-	20	V	static;
Gate source voltage (dynamic)	$V_{GS}$	-30	-	30	V	AC ( $f>1\text{ Hz}$ )
Power dissipation (TO220F)	$P_{tot}$	-	-	34	W	$T_C=25^\circ\text{C}$
Power dissipation (TO247&263)	$P_{tot}$	-	-	195	W	$T_C=25^\circ\text{C}$
Storage temperature	$T_{stg}$	-55	-	150	$^\circ\text{C}$	
Operating junction temperature	$T_j$	-55	-	150	$^\circ\text{C}$	
Soldering Temperature Distance of 1.6mm from case for 10s	$T_L$			260	$^\circ\text{C}$	
Reverse diode dv/dt <sup>3)</sup>	dv/dt	-	-	15	V/ns	$V_{DS}=0\dots400\text{V}, I_{SD}\leq 48\text{A}, T_j=25^\circ\text{C}$ see table 8

<sup>1)</sup>Limited by  $T_{j,max}$ . Maximum Duty Cycle  $D = 0.50$

<sup>2)</sup>Pulse width  $t_p$  limited by  $T_{j,max}$

<sup>3)</sup>Identical low side and high side switch with identical  $R_G$

## 2 Thermal characteristics

**Table 3 Thermal characteristics (TO220F)**

Parameter	Symbol	Values			Unit	Note / Test Condition
		Min.	Typ.	Max.		
Thermal resistance, junction - case	$R_{thJC}$	-	-	3.65	°C/W	-
Thermal resistance, junction - ambient	$R_{thJA}$	-	-	80	°C/W	device on PCB, minimal footprint

### Thermal characteristics (TO247&263)

Parameter	Symbol	Values			Unit	Note / Test Condition
		Min.	Typ.	Max.		
Thermal resistance, junction - case	$R_{thJC}$	-	-	0.64	°C/W	-
Thermal resistance, junction - ambient	$R_{thJA}$	-	-	62	°C/W	device on PCB, minimal footprint

### 3 Electrical characteristics

at  $T_j=25^{\circ}\text{C}$ , unless otherwise specified

**Table 4 Static characteristics**

Parameter	Symbol	Values			Unit	Note / Test Condition
		Min.	Typ.	Max.		
Drain-source breakdown voltage	$V_{(BR)DSS}$	605	-	-	V	$V_{GS}=0V, I_D=250\mu A$
Gate threshold voltage	$V_{(GS)th}$	2.8		4.2	V	$V_{DS}=V_{GS}, I_D=250\mu A$
Zero gate voltage drain current	$I_{DSS}$	-	-	1	$\mu A$	$V_{DS}=600V, V_{GS}=0V, T_j=25^{\circ}\text{C}$
Gate-source leakage current	$I_{GSS}$	-	-	100	nA	$V_{GS}=30V, V_{DS}=0V$
Drain-source on-state resistance	$R_{DS(on)}$	-	0.12	0.15	$\Omega$	$V_{GS}=10V, I_D=10A, T_j=25^{\circ}\text{C}$
Gate resistance (Intrinsic)	$R_G$	-	5.8	-	$\Omega$	$f=1\text{MHz}$ , open drain

**Table 5 Dynamic characteristics**

Parameter	Symbol	Values			Unit	Note / Test Condition
		Min.	Typ.	Max.		
Input capacitance	$C_{iss}$	-	2389	-	pF	$V_{GS}=0V, V_{DS}=50V, f=10\text{kHz}$
Output capacitance	$C_{oss}$	-	218	-	pF	$V_{GS}=0V, V_{DS}=50V, f=10\text{kHz}$
Reverse transfer capacitance	$C_{rss}$	-	5.07	-	pF	$V_{GS}=0V, V_{DS}=50V, f=10\text{kHz}$
Turn-on delay time	$t_{d(on)}$	-	12.4	-	ns	$V_{DD}=400V, V_{GS}=13V, I_D=11.3A, R_G=1.7\Omega$ ; see table 9
Rise time	$t_r$	-	21.6	-	ns	$V_{DD}=400V, V_{GS}=13V, I_D=11.3A, R_G=1.7\Omega$ ; see table 9
Turn-off delay time	$t_{d(off)}$	-	50	-	ns	$V_{DD}=400V, V_{GS}=13V, I_D=11.3A, R_G=1.7\Omega$ ; see table 9
Fall time	$t_f$	-	18.4	-	ns	$V_{DD}=400V, V_{GS}=13V, I_D=11.3A, R_G=1.7\Omega$ ; see table 9

**Table 6 Gate charge characteristics**

Parameter	Symbol	Values			Unit	Note / Test Condition
		Min.	Typ.	Max.		
Gate to source charge	$Q_{gs}$	-	8.522	-	nC	$V_{DD}=400V, I_D=11.3A, V_{GS}=0$ to 10V
Gate to drain charge	$Q_{gd}$	-	8.297	-	nC	$V_{DD}=400V, I_D=11.3A, V_{GS}=0$ to 10V
Gate charge total	$Q_g$	-	47.59	-	nC	$V_{DD}=400V, I_D=11.3A, V_{GS}=0$ to 10V
Gate plateau voltage	$V_{plateau}$	-	5.4	-	V	$V_{DD}=400V, I_D=11.3A, V_{GS}=0$ to 10V

**Table 7 Reverse diode characteristics**

Parameter	Symbol	Values			Unit	Note / Test Condition
		Min.	Typ.	Max.		
Diode forward voltage	$V_{SD}$	-	0.7	-	V	$V_{GS}=0V, I_F=1A, T_J=25^{\circ}C$
Reverse recovery time	$t_{rr}$	-	288	-	ns	$V_R=400V, I_F=11.3A, di_F/dt=100A/\mu s$ ; see table 8
Reverse recovery charge	$Q_{rr}$	-	4.3	-	$\mu C$	$V_R=400V, I_F=11.3A, di_F/dt=100A/\mu s$ ; see table 8
Peak reverse recovery current	$I_{rrm}$	-	26.2	-	A	$V_R=400V, I_F=11.3A, di_F/dt=100A/\mu s$ ; see table 8

### 4 Electrical characteristics diagram

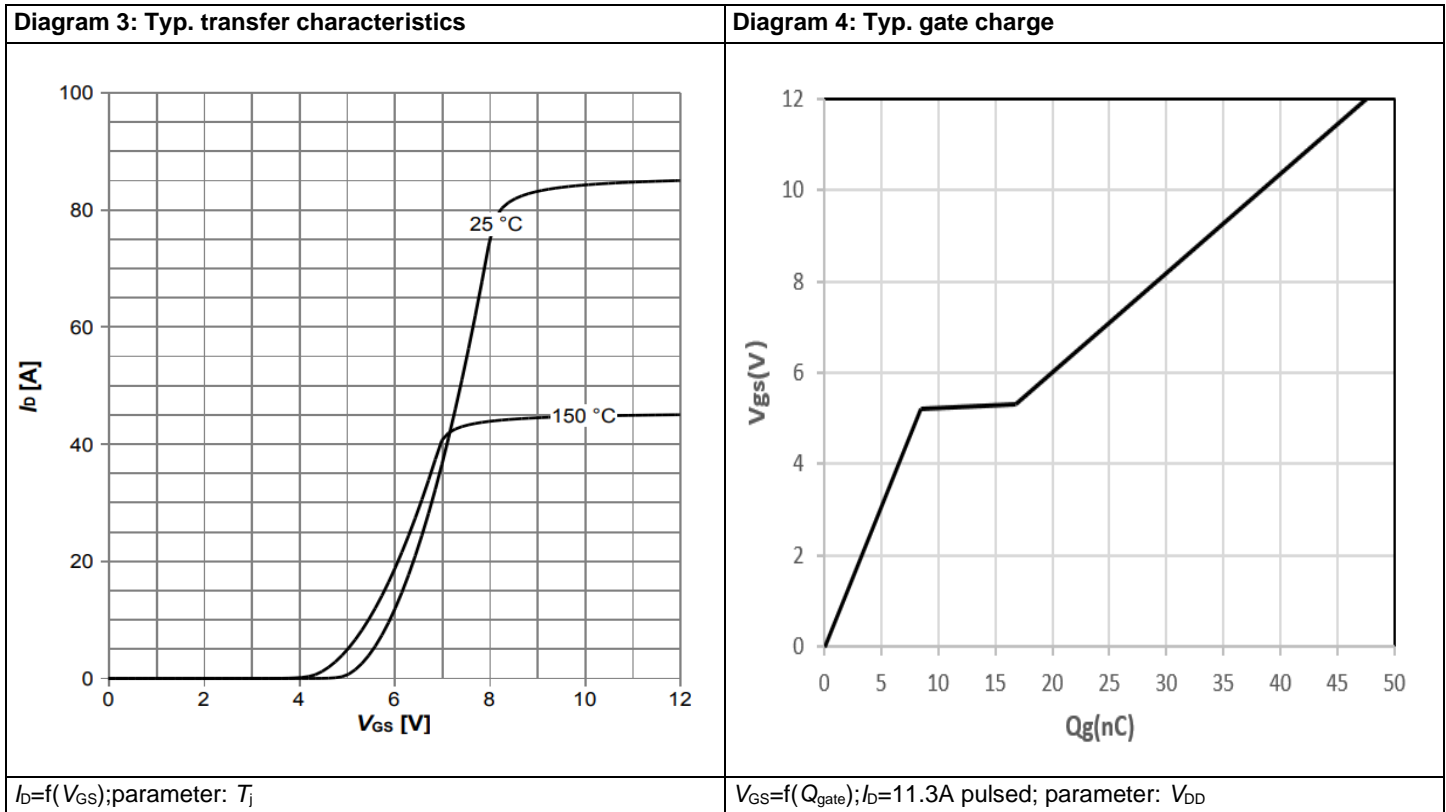
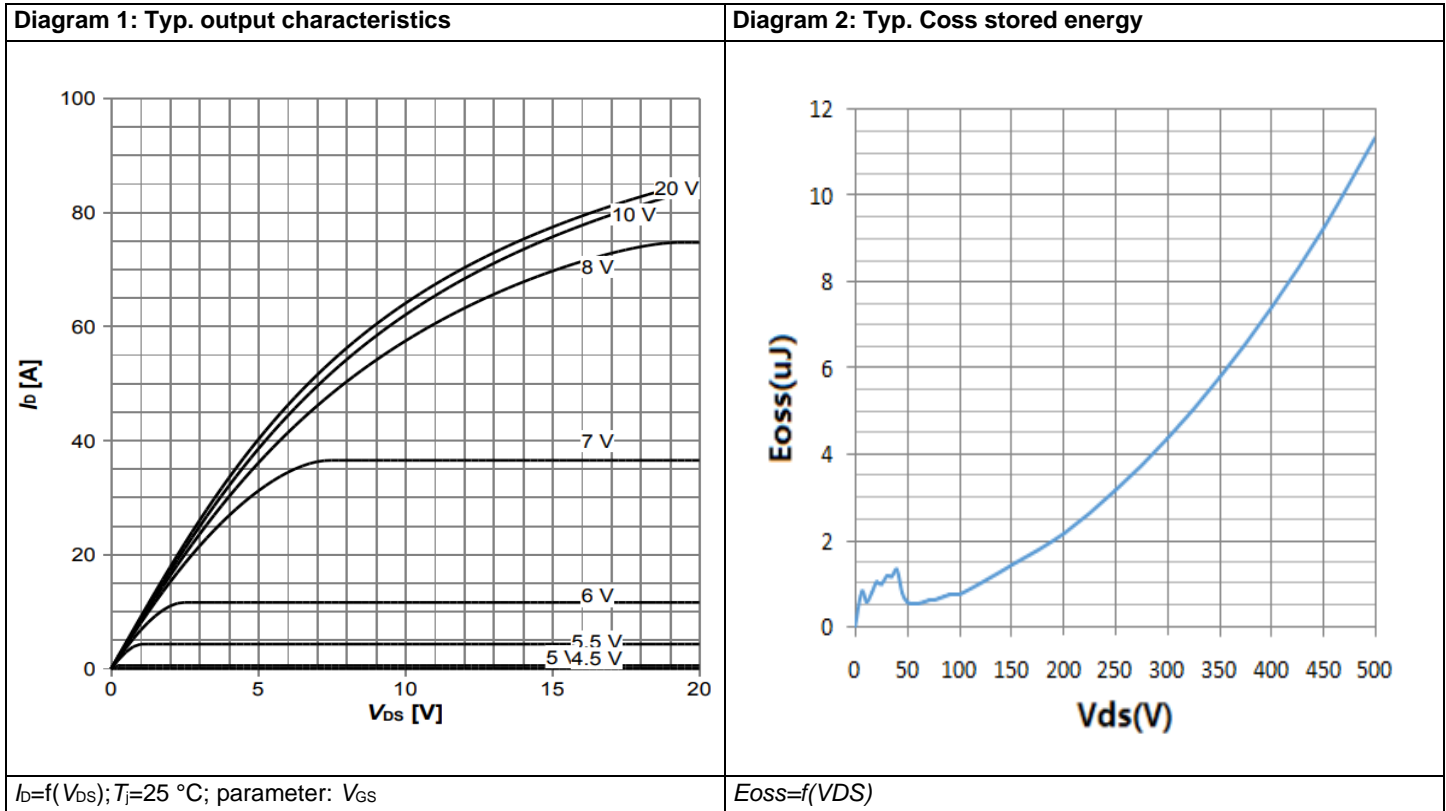
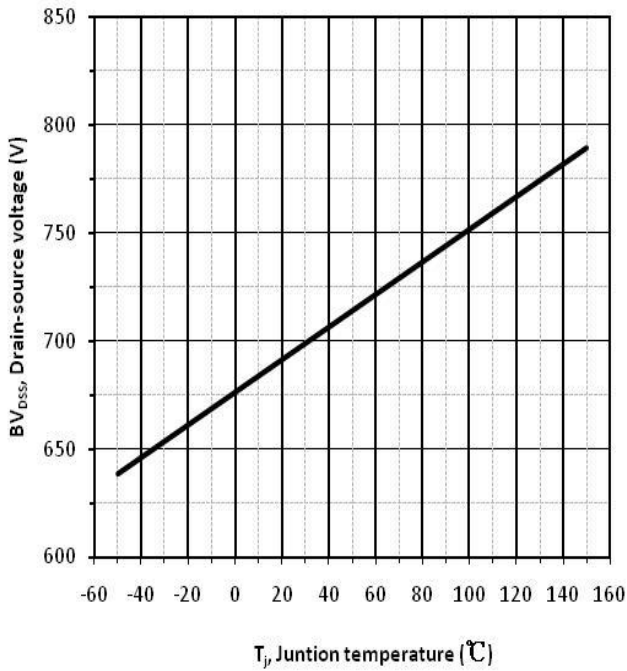
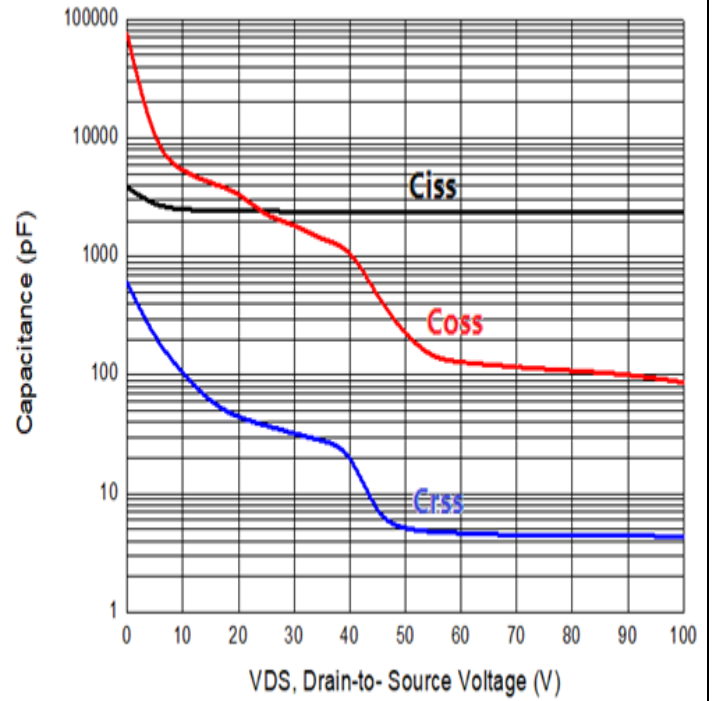


Diagram 5: Drain-source breakdown voltage



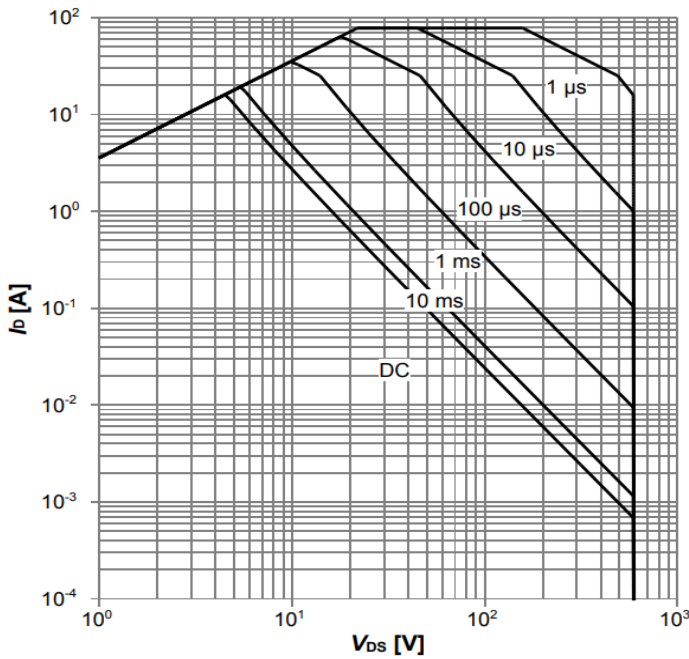
$V_{BR(DSS)}=f(T_j); I_D=10mA$

Diagram 6: Typ. capacitances



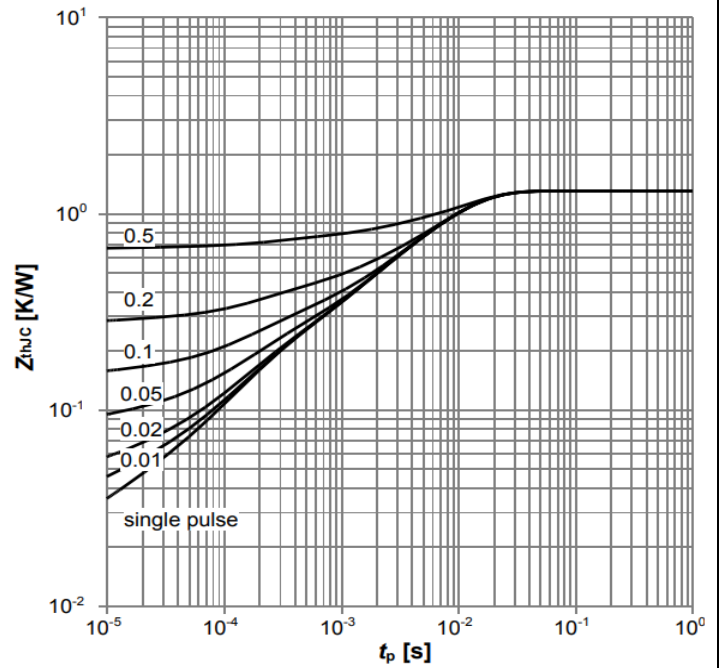
$C=f(V_{DS}); V_{GS}=0V; f=10\text{ kHz}$

Diagram 7: Maximum Safe Operating Area



$I_D=f(V_{DS}); T_C=25\text{ °C}; D=0; \text{parameter } t_p$

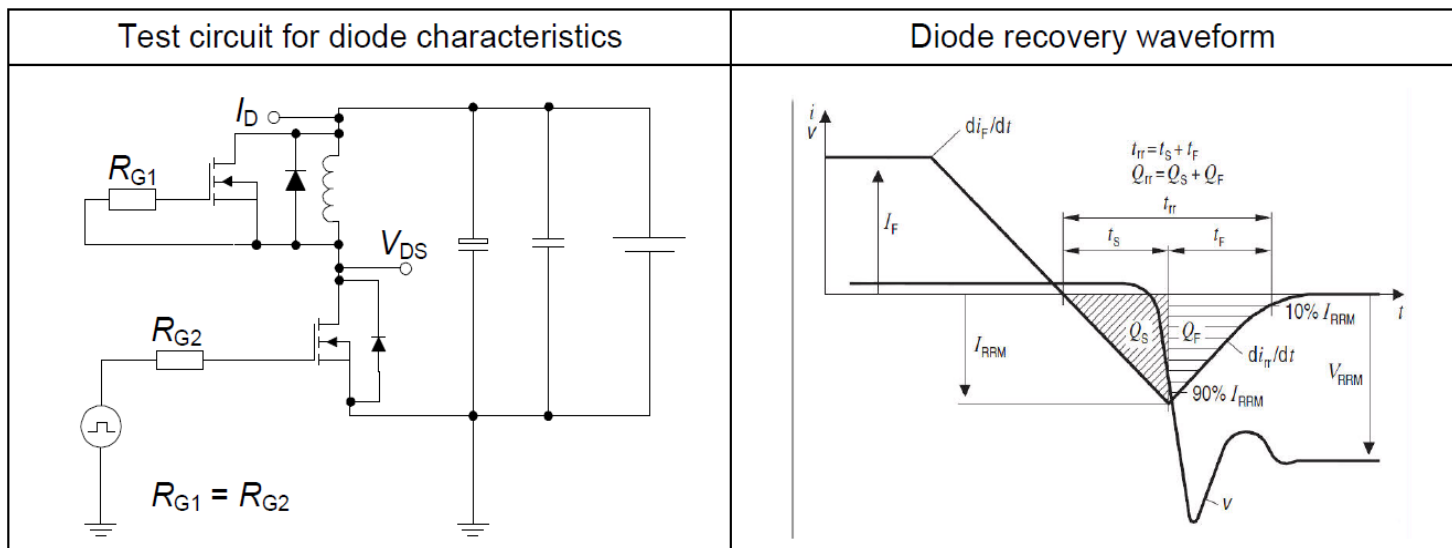
Diagram 8: Typ. Max. transient thermal impedance



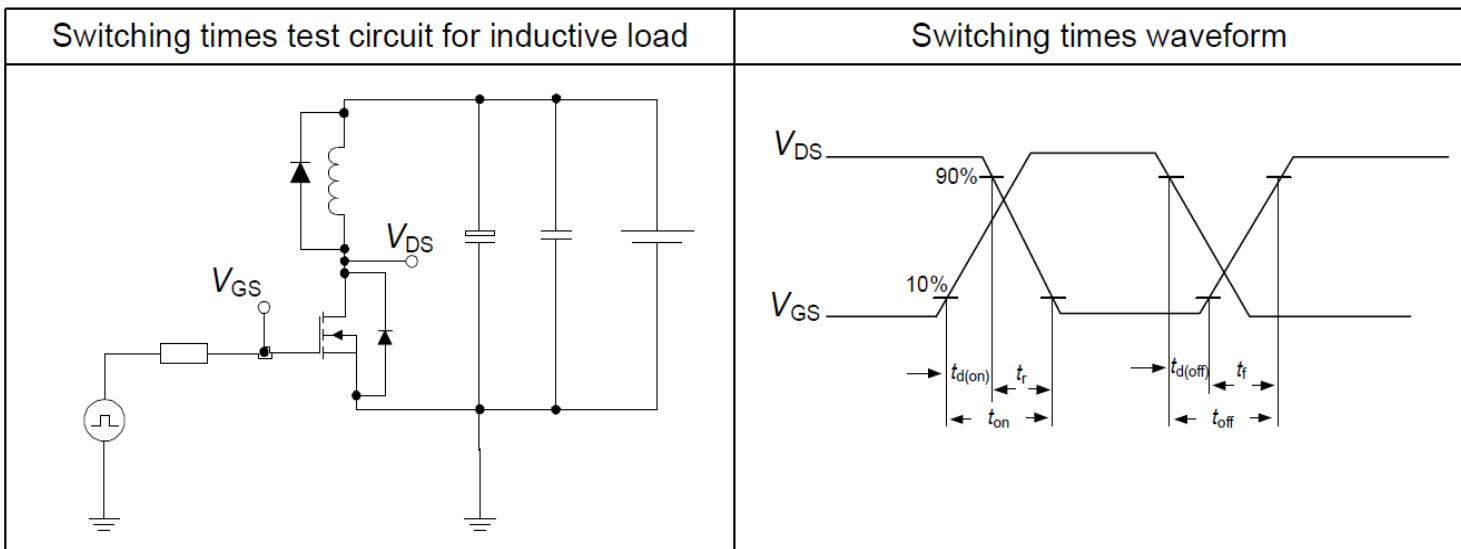
$Z_{thJC}=f(t_p); \text{parameter: } D=t_p/T$

## 5 Test Circuits

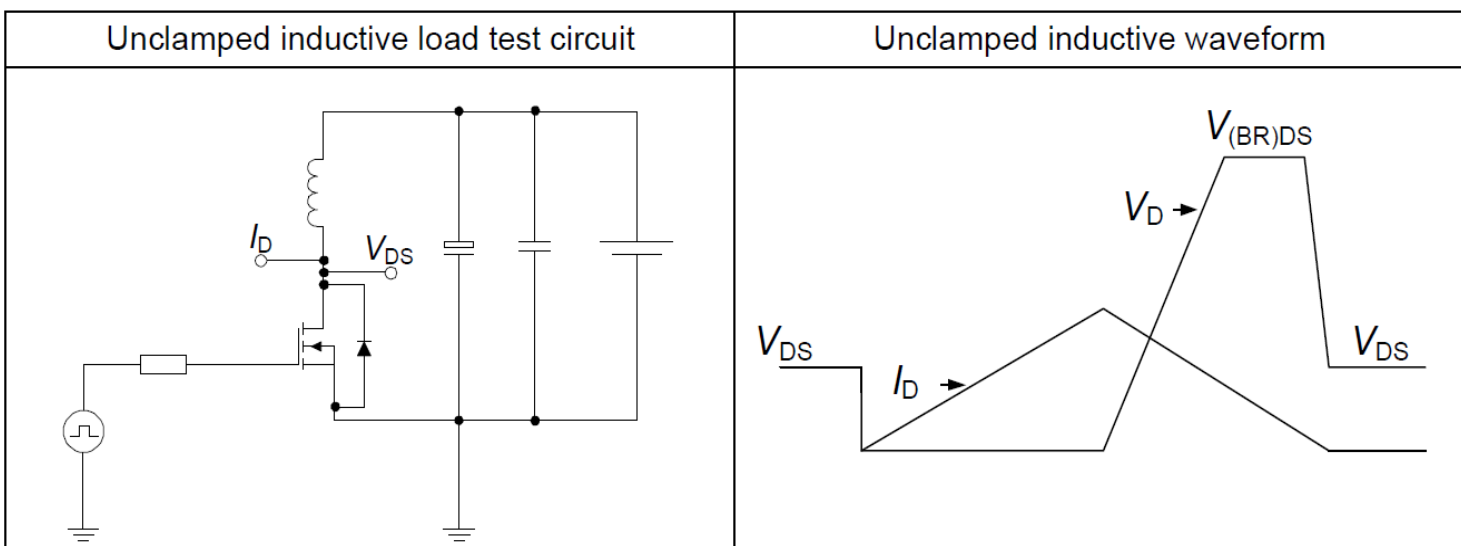
**Table 8 Diode characteristics**



**Table 9 Switching times**

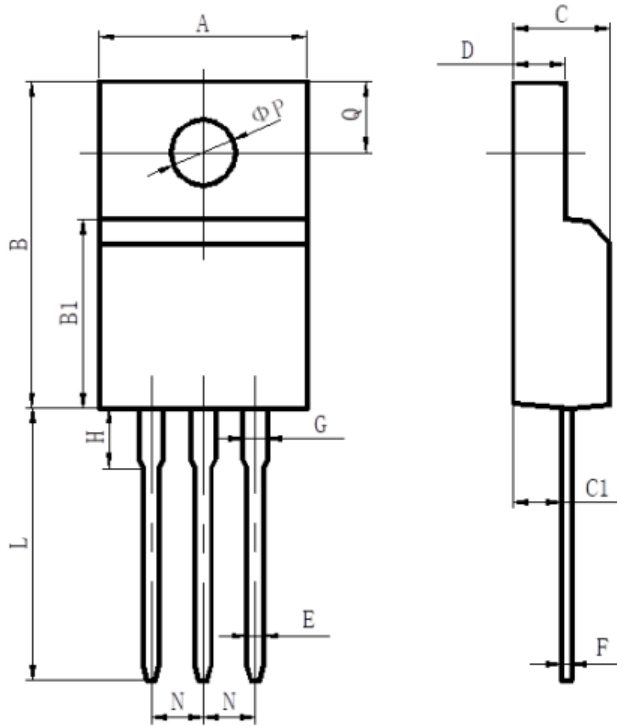


**Table 10 Unclamped inductive load**



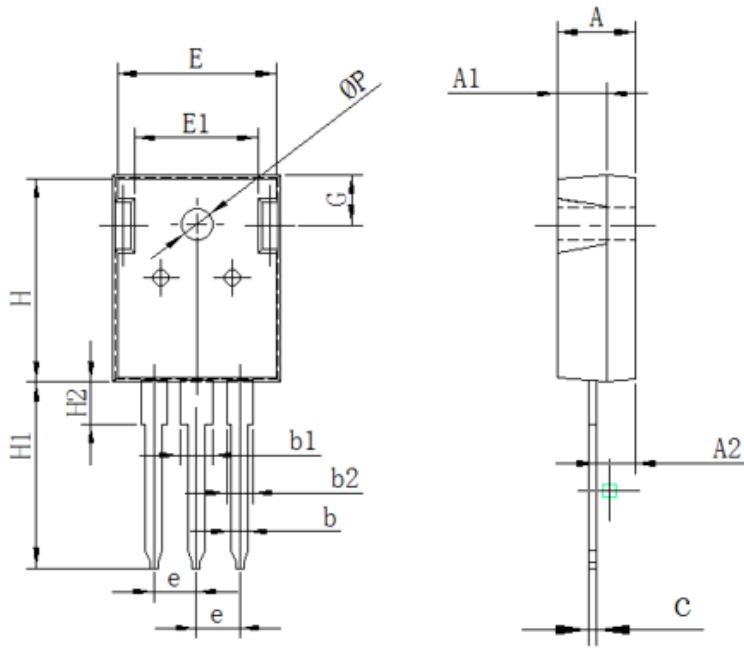


## 6 Package Outlines



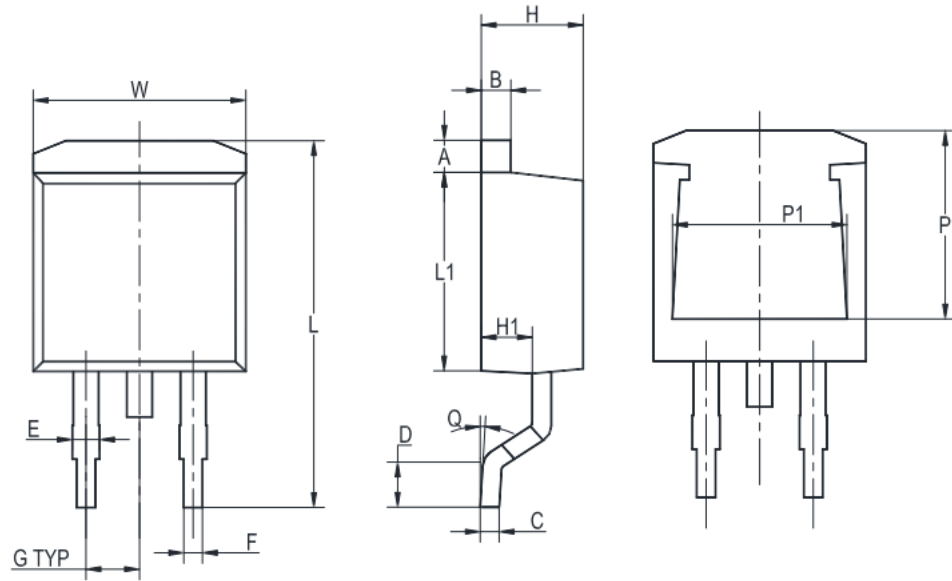
项目	规范(mm)	
	MIN	MAX
A	9.70	10.30
B	15.50	16.10
B1	8.99	9.39
C	4.40	4.80
C1	2.15	2.55
D	2.50	2.90
E	0.70	0.90
F	0.40	0.60
G	1.12	1.42
H	3.40	3.80
L	12.6	13.6
N	2.34	2.74
Q	3.15	3.55
$\phi P$	3.00	3.30

Figure1: Outline PG-T0220F(HT)



Symbol	单位 mm		
	Min	Nom	Max
A	4.8	5.00	5.20
A1	3.3	3.5	3.7
A2	2.20	2.40	2.60
b	1.00	1.2	1.40
b1	2.90	3.10	3.30
b2	1.90	2.10	2.30
c	0.50	0.60	0.70
e	5.25	5.45	5.65
E	15.2	15.7	16.2
E1	10.2	10.7	11.2
H	20.8	21	21.2
H1	19.5	20.0	20.5
H2	4.00	4.20	4.40
G	5.60	5.80	600
ΦP	3.50	3.70	3.90

Figure2: Outline PG-T0247(CD)



UNIT	A	B	C	D	E	F	G	W	H	H1	L	L1	Q	P	P1
mm	1.5	1.5	0.5	2.60	1.6	0.94	2.54	10.5	4.8	2.9	16.5	8.7	8°	7.6	8.2
	1.1	1.1	0.3	2.15	1.1	0.68	TYP	9.6	4.4	2.5	14.5	8.2	MAX	7.1	7.4

Figure3: Outline PG-TO263(HC)

## Revision History

Revision	Date	Subjects (major changes since last revision)
1.0	2019-04-16	Preliminary version
2.0	2020-03-19	Add part name "ASW60R150E" and Add Electrical characteristics Curve
2.1	2020-04-18	Add avalanche energy test condition, avalanche current data and test condition
2.2	2022-06-18	Updated TO220F POD to HT and TO247 POD to CD
2.3	2023-12-13	Added TO263 package

## X-ON Electronics

Largest Supplier of Electrical and Electronic Components

*Click to view similar products for [MOSFET](#) category:*

*Click to view products by [ANHI](#) manufacturer:*

Other Similar products are found below :

[IRFD120](#) [IRFY240C](#) [JANTX2N5237](#) [2SK2267\(Q\)](#) [BUK455-60A/B](#) [MIC4420CM-TR](#) [VN1206L](#) [NDP4060](#) [SI4482DY](#)  
[IPS70R2K0CEAKMA1](#) [SQD23N06-31L-GE3](#) [TK16J60W,S1VQ\(O](#) [2SK2614\(TE16L1,Q\)](#) [DMN1017UCP3-7](#) [EFC2J004NUZTDG](#)  
[DMN1053UCP4-7](#) [SQJ469EP-T1-GE3](#) [NTE2384](#) [DMC2700UDMQ-7](#) [DMN2080UCB4-7](#) [DMN61D9UWQ-13](#) [US6M2GTR](#)  
[DMN31D5UDJ-7](#) [DMP22D4UFO-7B](#) [DMN1006UCA6-7](#) [DMN16M9UCA6-7](#) [STF5N65M6](#) [IRF40H233XTMA1](#) [STU5N65M6](#)  
[DMN6022SSD-13](#) [DMN13M9UCA6-7](#) [DMTH10H4M6SPS-13](#) [DMN2990UFB-7B](#) [IPB80P04P405ATMA2](#) [2N7002W-G](#) [MCAC30N06Y-](#)  
[TP](#) [MCQ7328-TP](#) [NTMC083NP10M5L](#) [NVMFS2D3P04M8LT1G](#) [BXP7N65D](#) [BXP4N65F](#) [AOL1454G](#) [WMJ80N60C4](#) [BXP2N20L](#)  
[BXP2N65D](#) [BXT1150N10J](#) [BXT1700P06M](#) [TSM60NB380CP](#) [ROG](#) [RQ7L055BGTCR](#) [DMNH15H110SK3-13](#)