

MOSFET Silicon N-Channel MOS

1. Applications

Single-ended flyback or two-transistor forward topologies.
PC power, PD Adaptor, LCD & PDP TV and LED lighting.



2. Features

Low drain-source on-resistance: $R_{DS(ON)} = 0.346\Omega$ (typ.)
Easy to control Gate switching
Enhancement mode: $V_{th} = 2.8$ to 4.2 V



Table 1 Key Performance Parameters

Parameter	Value	Unit
$V_{DS} @ T_{j,max}$	750	V
$R_{DS(on),max}$	380	m Ω
$Q_{g,typ}$	22	nC
$I_{D,pulse}$	33	A

3. Packaging and Internal Circuit

Part Name	Package	Marking
ASA70R380E	TO220F	ASA70R380E
ASD70R380E	TO252	ASD70R380E
ASB70R380E	TO263	ASB70R380E

TO220F	TO252	TO263

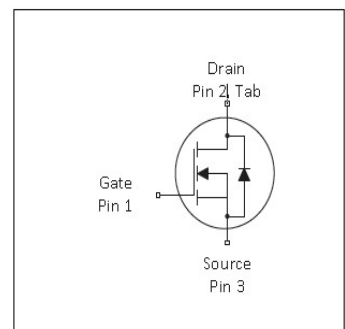

1 Maximum ratings
at $T_j = 25^\circ\text{C}$, unless otherwise specified

Table 2 Maximum ratings

Parameter	Symbol	Values			Unit	Note / Test Condition
		Min.	Typ.	Max.		
Continuous drain current ¹⁾	I_D		-	11	A	$T_C=25^\circ\text{C}$
Pulsed drain current ²⁾	$I_{D,pulse}$	-	-	33	A	$T_C=25^\circ\text{C}$
Avalanche energy, single pulse	E_{AS}	-	-	624	mJ	
MOSFET dv/dt ruggedness	dv/dt	-	-	69	V/ns	$V_{DS}=0\dots400\text{V}$
Gate source voltage (static)	V_{GS}	-20	-	20	V	static;
Gate source voltage (dynamic)	V_{GS}	-30	-	30	V	AC ($f > 1\text{ Hz}$)
Power dissipation (TO220F)	P_{tot}	-	-	31	W	$T_C=25^\circ\text{C}$
Power dissipation (TO252&TO263)	P_{tot}	-	-	83	W	$T_C=25^\circ\text{C}$
Storage temperature	T_{stg}	-55	-	150	$^\circ\text{C}$	
Operating junction temperature	T_j	-55	-	150	$^\circ\text{C}$	
Reverse diode dv/dt ³⁾	dv/dt	-	-	15	V/ns	$V_{DS}=0\dots400\text{V}$, $I_{SD} \leq 48\text{A}$, $T_j=25^\circ\text{C}$ see table 8

release

¹⁾ Limited by $T_{j,max}$. Maximum Duty Cycle $D = 0.50$
²⁾ Pulse width t_p limited by $T_{j,max}$
³⁾ Identical low side and high side switch with identical R_G

2 Thermal characteristics

Table 3 Thermal characteristics (T0220 FullPAK)

Parameter	Symbol	Values			Unit	Note / Test Condition
		Min.	Typ.	Max.		
Thermal resistance, junction - case	R_{thJC}	-	-	4	°C/W	-
Thermal resistance, junction - ambient	R_{thJA}	-	-	80	°C/W	device on PCB, minimal footprint

Thermal characteristics (T0252 and T0263)

Parameter	Symbol	Values			Unit	Note / Test Condition
		Min.	Typ.	Max.		
Thermal resistance, junction - case	R_{thJC}	-	-	1.5	°C/W	-
Thermal resistance, junction - ambient	R_{thJA}	-	-	62	°C/W	device on PCB, minimal footprint

Not for release

3 Electrical characteristics

at $T_j=25^{\circ}\text{C}$, unless otherwise specified

Table 4 Static characteristics

Parameter	Symbol	Values			Unit	Note / Test Condition
		Min.	Typ.	Max.		
Drain-source breakdown voltage	$V_{(BR)DSS}$	705	-	-	V	$V_{GS}=0\text{V}, I_D=10\text{mA}$
Gate threshold voltage	$V_{(GS)th}$	2.8		4.2	V	$V_{DS}=V_{GS}, I_D=250\mu\text{A}$
Zero gate voltage drain current	I_{DSS}	-	-	100	nA	$V_{DS}=700\text{V}, V_{GS}=0\text{V}, T_j=25^{\circ}\text{C}$
Gate-source leakage current	I_{GSS}	-	-	100	nA	$V_{GS}=30\text{V}, V_{DS}=0\text{V}$
Drain-source on-state resistance	$R_{DS(on)}$	-	0.346	0.38	Ω	$V_{GS}=10\text{V}, I_D=5.5\text{A}, T_j=25^{\circ}\text{C}$
Gate resistance	R_G	-	11.2	-	Ω	$f=1\text{MHz}$, open drain

Table 5 Dynamic characteristics

Parameter	Symbol	Values			Unit	Note / Test Condition
		Min.	Typ.	Max.		
Input capacitance	C_{iss}	-	901	-	pF	$V_{GS}=0\text{V}, V_{DS}=50\text{V}, f=10\text{kHz}$
Output capacitance	C_{oss}	-	59	-	pF	$V_{GS}=0\text{V}, V_{DS}=50\text{V}, f=10\text{kHz}$
Reverse transfer capacitance	C_{rss}	-	5.3	-	pF	$V_{GS}=0\text{V}, V_{DS}=50\text{V}, f=10\text{kHz}$
Turn-on delay time	$t_{d(on)}$	-	7.2	-	ns	$V_{DD}=400\text{V}, V_{GS}=13\text{V}, I_D=4.8\text{A}, R_G=3.4\Omega$; see table 9
Rise time	t_r	-	20.8	-	ns	$V_{DD}=400\text{V}, V_{GS}=13\text{V}, I_D=4.8\text{A}, R_G=3.4\Omega$; see table 9
Turn-off delay time	$t_{d(off)}$	-	29.2	-	ns	$V_{DD}=400\text{V}, V_{GS}=13\text{V}, I_D=4.8\text{A}, R_G=3.4\Omega$; see table 9
Fall time	t_f	-	19.2	-	ns	$V_{DD}=400\text{V}, V_{GS}=13\text{V}, I_D=4.8\text{A}, R_G=3.4\Omega$; see table 9

Table 6 Gate charge characteristics

Parameter	Symbol	Values			Unit	Note / Test Condition
		Min.	Typ.	Max.		
Gate to source charge	Q_{gs}	-	5.8	-	nC	$V_{DD}=400\text{V}, I_D=4.8\text{A}, V_{GS}=0$ to 10V
Gate to drain charge	Q_{gd}	-	17	-	nC	$V_{DD}=400\text{V}, I_D=4.8\text{A}, V_{GS}=0$ to 10V
Gate charge total	Q_g	-	22	-	nC	$V_{DD}=400\text{V}, I_D=4.8\text{A}, V_{GS}=0$ to 10V
Gate plateau voltage	$V_{plateau}$	-	5.3	-	V	$V_{DD}=400\text{V}, I_D=4.8\text{A}, V_{GS}=0$ to 10V

Table 7 Reverse diode characteristics

Parameter	Symbol	Values			Unit	Note / Test Condition
		Min.	Typ.	Max.		
Diode forward voltage	V_{SD}	-	0.74	-	V	$V_{GS}=0V, I_F=1A, T_j=25^{\circ}C$
Reverse recovery time	t_{rr}	-	250	-	ns	$V_R=400V, I_F=4.8 A, di_F/dt=100A/\mu s$; see table 8
Reverse recovery charge	Q_{rr}	-	2.572	-	uC	$V_R=400V, I_F=4.8 A, di_F/dt=100A/\mu s$; see table 8
Peak reverse recovery current	I_{rrm}	-	19.6	-	A	$V_R=400V, I_F=4.8 A, di_F/dt=100A/\mu s$; see table 8

release

4 Test Circuits

Table 8 Diode characteristics

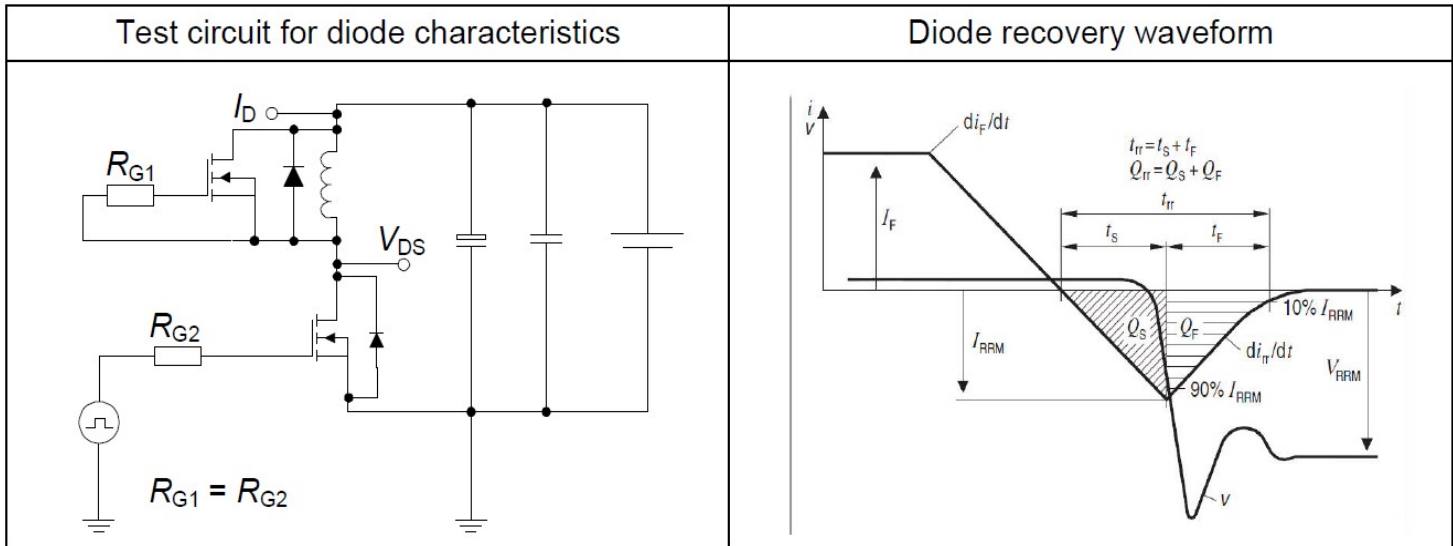

Table 9 Switching times

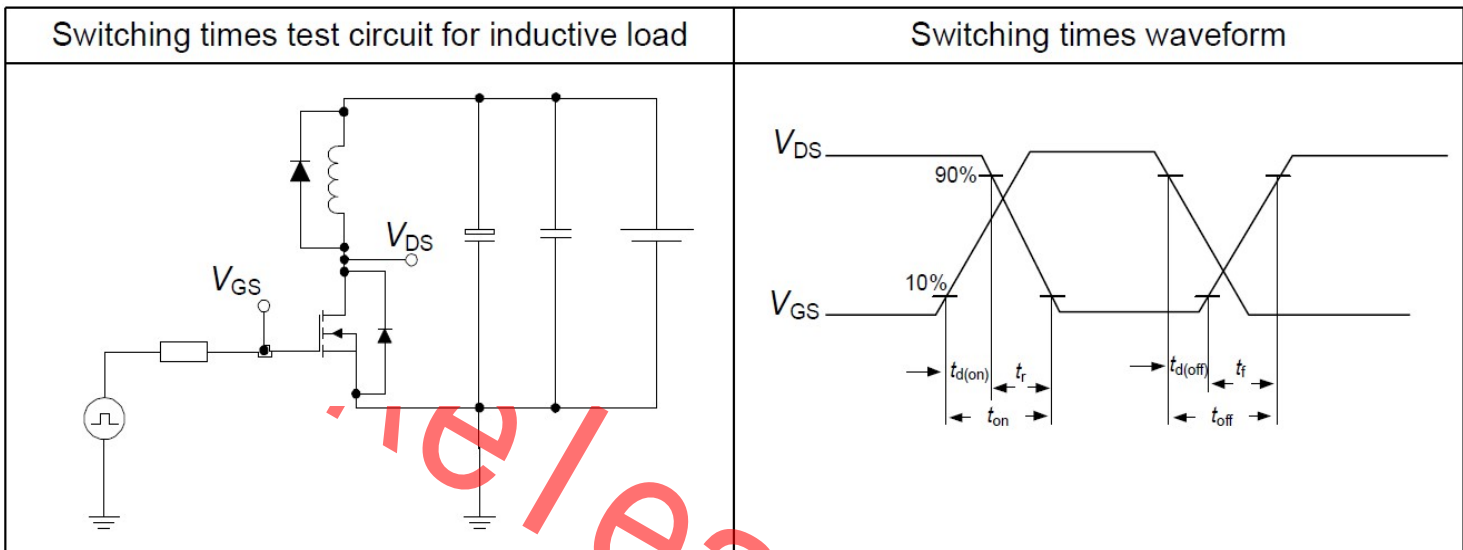
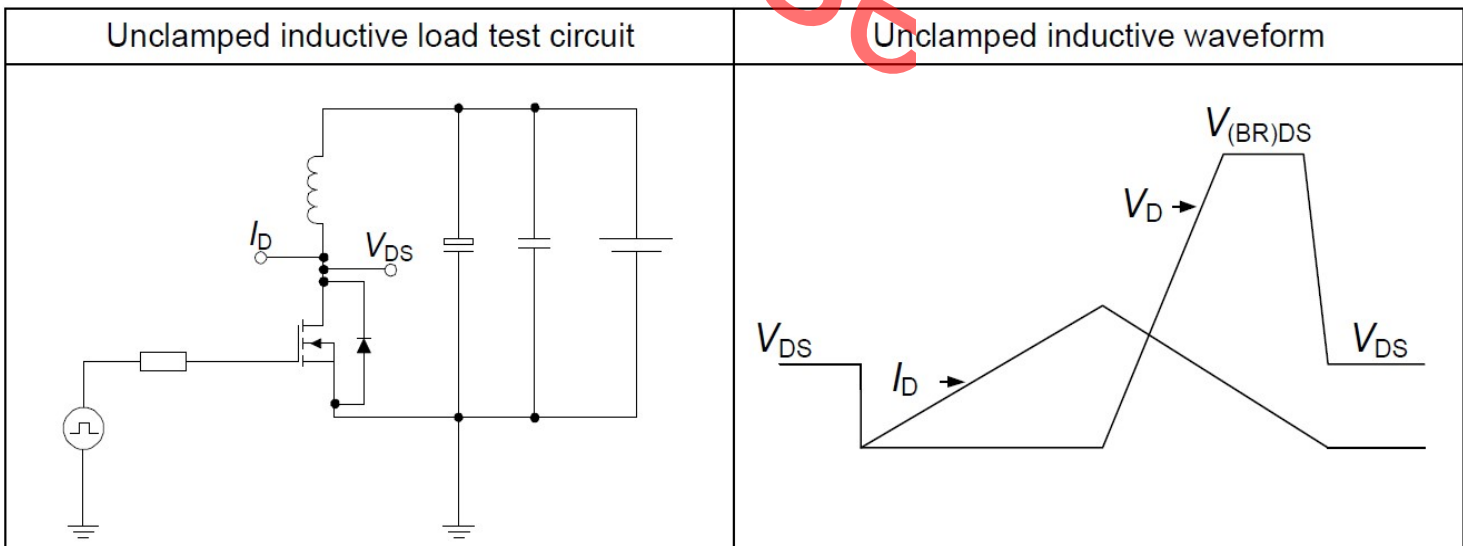

Table 10 Unclamped inductive load



5 Package Outlines

TO-220F

单位: mm

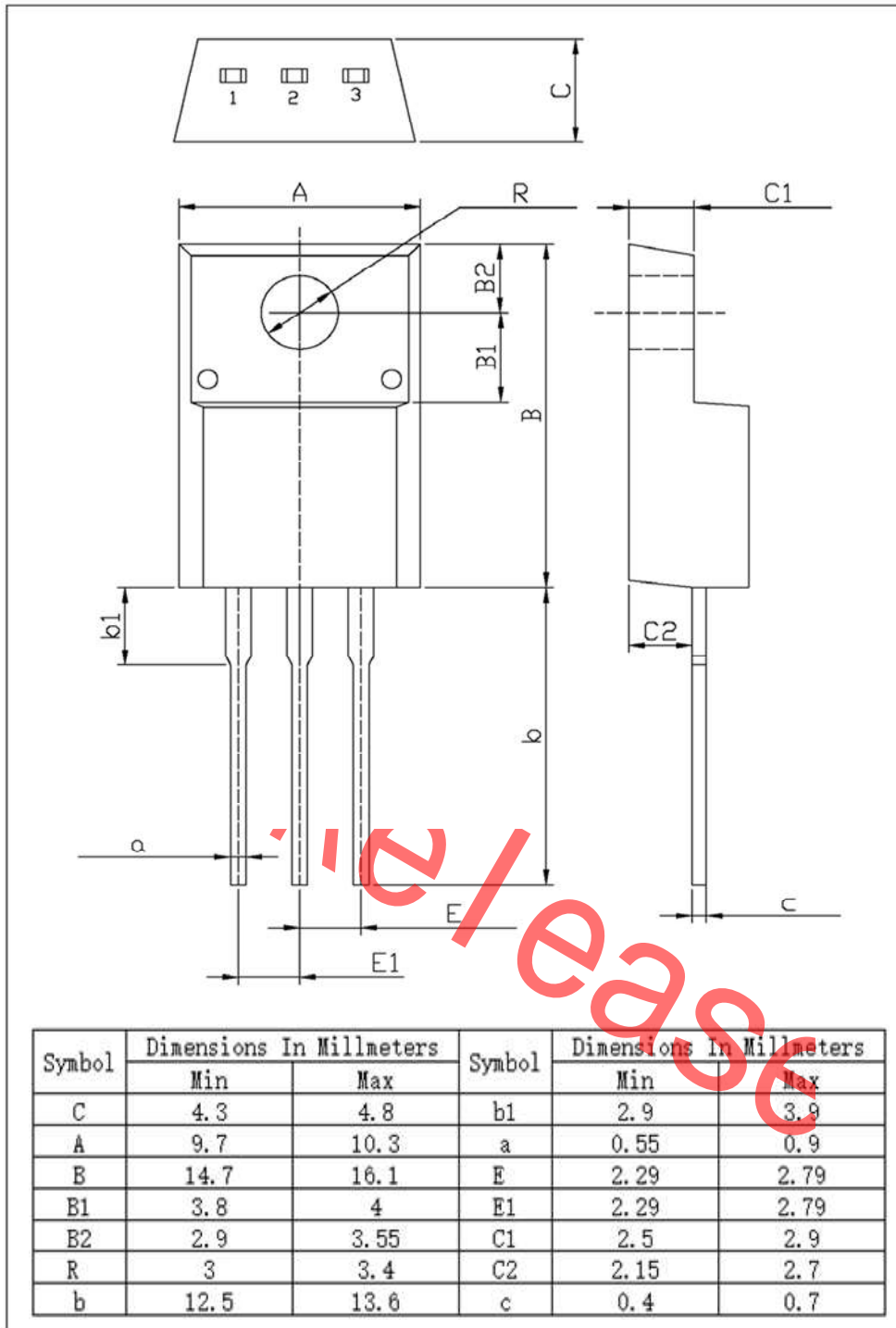
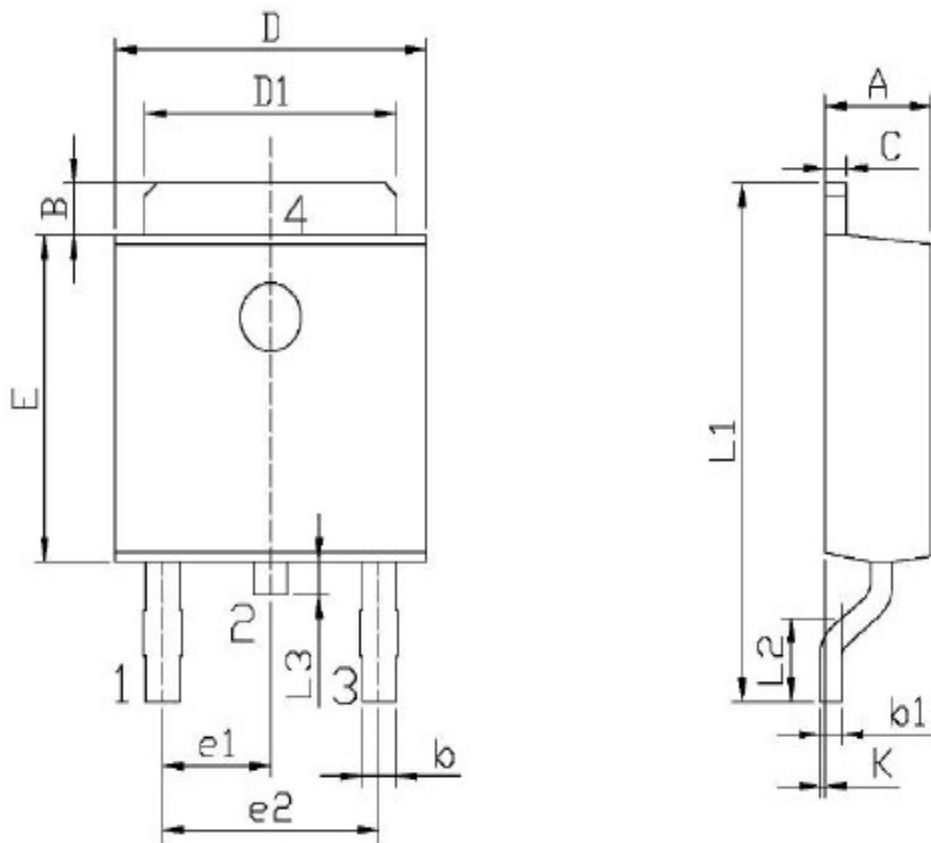

Figure1: Outline PG-T0220F



单位: mm

Symbol	Dimensions In Millimeters		Symbol	Dimensions In Millimeters	
	Min	Max		Min	Max
A	2.20	2.40	E	5.95	6.25
B	0.95	1.25	e1	2.24	2.34
b	0.50	0.70	e2	4.43	4.73
b1	0.45	0.55	L1	9.45	9.95
C	0.45	0.55	L2	1.25	1.75
D	6.45	6.75	L3	0.60	0.90
D1	5.10	5.50	K	0.00	0.10

Figure2: Outline PG-T0252

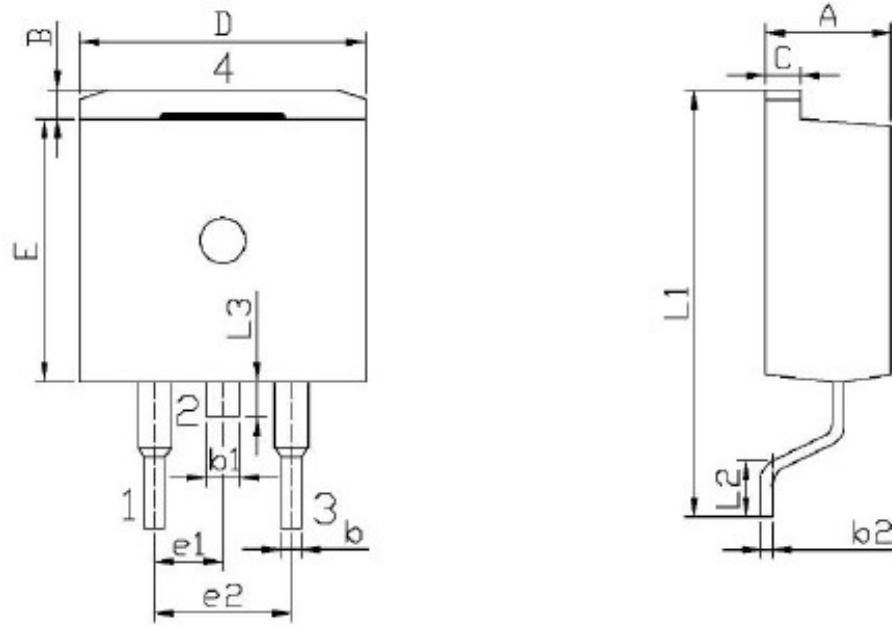

单位: mm

Symbol	Dimensions In Millimeters		Symbol	Dimensions In Millimeters	
	Min	Max		Min	Max
A	4.30	4.70	E	9.00	9.40
B	1.00	1.40	e1	2.34	2.74
b	0.70	0.90	e2	4.88	5.28
b1	1.15	1.35	L1	15.00	18.00
b2	0.40	0.60	L2	2.24	2.84
C	1.20	1.40	L3	1.20	1.60
D	9.80	10.20			

Figure3: Outline PG-T0263

Revision History

ASA70R380E

Revision	Date	Subjects (major changes since last revision)
0.1	2019-05-08	Preliminary version
1.0	2019-11-07	Fine tune outline and add Crss test data.etc

Pre-release

X-ON Electronics

Largest Supplier of Electrical and Electronic Components

Click to view similar products for [MOSFET](#) category:

Click to view products by [ANHI](#) manufacturer:

Other Similar products are found below :

[IRFD120](#) [IRFY240C](#) [JANTX2N5237](#) [2SK2267\(Q\)](#) [BUK455-60A/B](#) [MIC4420CM-TR](#) [VN1206L](#) [NDP4060](#) [SI4482DY](#)
[IPS70R2K0CEAKMA1](#) [SQD23N06-31L-GE3](#) [TK16J60W,S1VQ\(O](#) [2SK2614\(TE16L1,Q\)](#) [DMN1017UCP3-7](#) [EFC2J004NUZTDG](#)
[DMN1053UCP4-7](#) [SQJ469EP-T1-GE3](#) [NTE2384](#) [DMC2700UDMQ-7](#) [DMN2080UCB4-7](#) [DMN61D9UWQ-13](#) [US6M2GTR](#)
[DMN31D5UDJ-7](#) [DMP22D4UFO-7B](#) [DMN1006UCA6-7](#) [DMN16M9UCA6-7](#) [STF5N65M6](#) [IRF40H233XTMA1](#) [STU5N65M6](#)
[DMN6022SSD-13](#) [DMN13M9UCA6-7](#) [DMTH10H4M6SPS-13](#) [DMN2990UFB-7B](#) [IPB80P04P405ATMA2](#) [2N7002W-G](#) [MCAC30N06Y-](#)
[TP](#) [MCQ7328-TP](#) [NTMC083NP10M5L](#) [NVMFS2D3P04M8LT1G](#) [BXP7N65D](#) [BXP4N65F](#) [AOL1454G](#) [WMJ80N60C4](#) [BXP2N20L](#)
[BXP2N65D](#) [BXT1150N10J](#) [BXT1700P06M](#) [TSM60NB380CP](#) [ROG](#) [RQ7L055BGTCR](#) [DMNH15H110SK3-13](#)