

MOSFET Silicon N-Channel MOS



1. Applications

Synchronous rectification in SMPS,
Hard switching and High speed circuit
DC/DC in telecoms and industrial

2. Features

Low drain-source on-resistance: $R_{DS(on)}=4.1\text{m}\Omega$ (typ.)
High speed power switching
Enhanced body diode dv/dt capability
Enhanced avalanche ruggedness

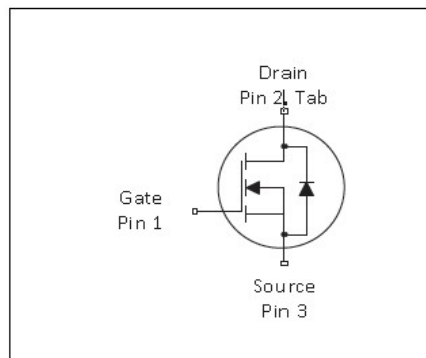
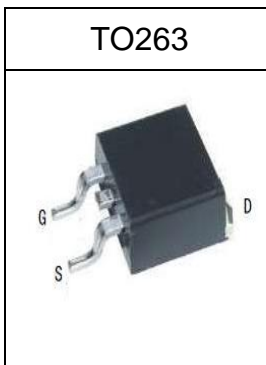

Table 1 Key Performance Parameters

Parameter	Value	Unit
$V_{DS} @ T_{j,max}$	100	V
$R_{DS(on),max}$	4.5	$\text{m}\Omega$
$Q_{g,typ}$	97.3	nC
$I_{D,pulse}$	486	A

3. Packaging and Internal Circuit

Part Name	Package	Marking
AUB045N10BT	TO263	AUB045N10BT



1 Maximum ratings

At $T_j = 25^\circ\text{C}$, unless otherwise specified

Table 2 Maximum ratings

Parameter	Symbol	Values			Unit	Note / Test Condition
		Min.	Typ.	Max.		
Continuous drain current at sikicon ¹⁾	I_D		-	176	A	$T_C = 25^\circ\text{C}$
Continuous drain current at package ¹⁾	I_D		-	123	A	$T_C = 25^\circ\text{C}$
Continuous drain current at silicon ¹⁾	I_D			112	A	$T_C = 100^\circ\text{C}$
Pulsed drain current ²⁾	$I_{D,pulse}$	-		486	A	$T_C = 25^\circ\text{C}$
Avalanche energy, single pulse	E_{AS}	-	-	441	mJ	$T_C = 25^\circ\text{C}$, $V_{DD} = 50\text{V}$, $V_{gs} = 10\text{V}$, $L = 0.5\text{mH}$, $R_G = 25\Omega$
Avalanche current, single pulse	I_{AR}	-	-	42	A	$T_C = 25^\circ\text{C}$, $V_{DD} = 50\text{V}$, $L = 0.5\text{mH}$, $R_G = 25\Omega$
Gate source voltage (static)	V_{GS}	-20	-	20	V	static;
Power dissipation	P_{tot}	-	-	229	W	$T_C = 25^\circ\text{C}$
Storage temperature	T_{stg}	-55	-	150	$^\circ\text{C}$	
Operating junction temperature	T_j	-55	-	150	$^\circ\text{C}$	
Soldering Temperature Distance of 1.6mm from case for 10s	T_L			260	$^\circ\text{C}$	

¹⁾Limited by $T_{j,max}$. Maximum Duty Cycle $D = 0.50$

²⁾Pulse width t_p limited by $T_{j,max}$

³⁾Identical low side and high side switch with identical R_G

2 Thermal characteristics

Table Thermal characteristics

Parameter	Symbol	Values			Unit	Note / Test Condition
		Min.	Typ.	Max.		
Thermal resistance, junction - case	R_{thJC}	-	-	0.54	°C/W	-
Thermal resistance, junction - ambient	R_{thJA}	-	-	62	°C/W	device on PCB, minimal footprint

3 Electrical characteristics

at $T_j=25^\circ\text{C}$, unless otherwise specified

Table 4 Static characteristics

Parameter	Symbol	Values			Unit	Note / Test Condition
		Min.	Typ.	Max.		
Drain-source breakdown voltage	$V_{(BR)DSS}$	100	-	-	V	$V_{GS}=0V, I_D=250\mu A$
Gate threshold voltage	$V_{(GS)th}$	2.5	2.9	4.5	V	$V_{DS}=V_{GS}, I_D=250\mu A$
Zero gate voltage drain current	I_{DSS}	-	-	1	μA	$V_{DS}=100V, V_{GS}=0V, T_j=25^\circ C$
Gate-source leakage current	I_{GSS}	-	-	+/-100	nA	$V_{GS}=\pm 20V, V_{DS}=0V$
Drain-source on-state resistance	$R_{DS(on)}$	-	4.1	4.5	m Ω	$V_{GS}=10V, I_D=20A, T_j=25^\circ C$
Gate resistance (Intrinsic)	R_G	-	1.6	-	Ω	$f=1MHz, \text{open drain}$
Transconductance	G_{fs}		93.2		S	$V_{DS}=5V, I_D=50A$

Table 5 Dynamic characteristics

Parameter	Symbol	Values			Unit	Note / Test Condition
		Min.	Typ.	Max.		
Input capacitance	C_{iss}	-	5763	-	PF	$V_{GS}=0V, V_{DS}=50V, f=1MHz$
Output capacitance	C_{oss}	-	485.1	-	PF	$V_{GS}=0V, V_{DS}=50V, f=1MHz$
Reverse transfer capacitance	C_{riss}	-	22.4	-	PF	$V_{GS}=0V, V_{DS}=50V, f=1MHz$
Turn-on delay time	$t_{d(on)}$	-	16.6	-	ns	$V_{DD}=50V, V_{GS}=10V, I_D=50A, R_G=3\Omega$
Rise time	t_r	-	74	-	ns	$V_{DD}=50V, V_{GS}=10V, I_D=50A, R_G=3\Omega$
Turn-off delay time	$t_{d(off)}$	-	51	-	ns	$V_{DD}=50V, V_{GS}=10V, I_D=50A, R_G=3\Omega$
Fall time	t_f	-	53	-	ns	$V_{DD}=50V, V_{GS}=10V, I_D=50A, R_G=3\Omega$

Table 6 Gate charge characteristics

Parameter	Symbol	Values			Unit	Note / Test Condition
		Min.	Typ.	Max.		
Gate to source charge	Q_{gs}	-	20.9	-	nC	$V_{DD}=50V, I_D=20A, V_{GS}=10V$
Gate to drain charge	Q_{gd}	-	29.1	-	nC	$V_{DD}=50V, I_D=20A, V_{GS}=10V$
Gate charge total	Q_g	-	97.3	-	nC	$V_{DD}=50V, I_D=20A, V_{GS}=10V$

Table 7 Reverse diode characteristics

Parameter	Symbol	Values			Unit	Note / Test Condition
		Min.	Typ.	Max.		
Continuous Source Current at silicon	I_{SD}	-	-	176	A	Maximum Ratings
Diode forward voltage	V_{SD}	-	-	1.2	V	$V_{GS}=0V, I_s=1A, T_j=25^\circ C$
Reverse recovery time	t_{rr}	-	79	-	ns	$V_{GS}=0V, I_F=50A, di_F/dt=100A/\mu s$
Reverse recovery charge	Q_{rr}	-	141	-	nC	$V_{GS}=0V, I_F=50A, di_F/dt=100A/\mu s$
Peak Reverse Recovery Current	I_{rrm}	-	3.01	-	A	$V_{GS}=0V, I_F=50A, di_F/dt=100A/\mu s$

4 Electrical characteristics diagram

Diagram 1: Typ. Output characteristics

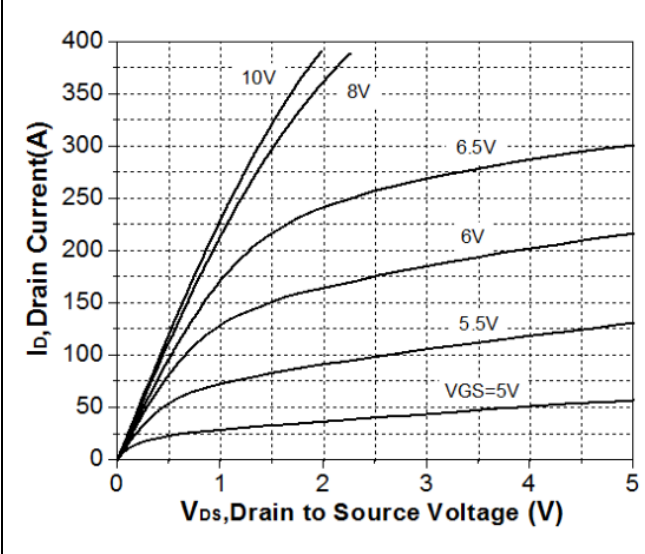

$I_D=f(V_{DS}); T_j=25\text{ }^\circ\text{C};$ parameter: V_{GS}

Diagram 2: Typ. Transfer characteristics

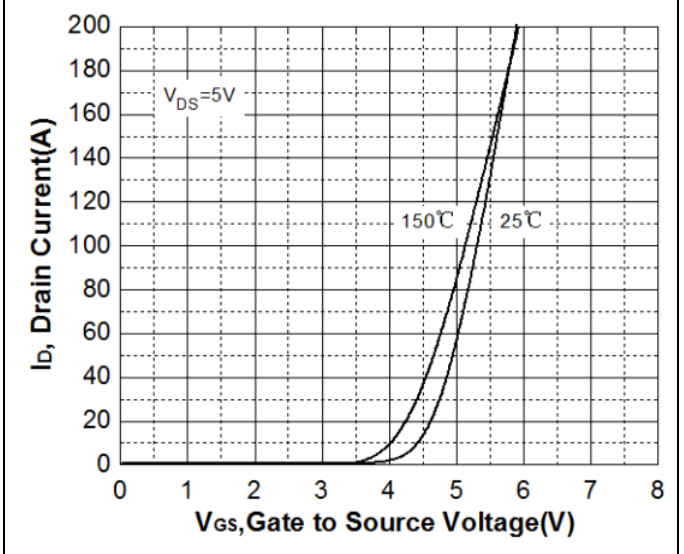

$I_D=f(V_{GS});$ parameter: T_j

Diagram 3: Typ. Rds(on) vs. Drain Current

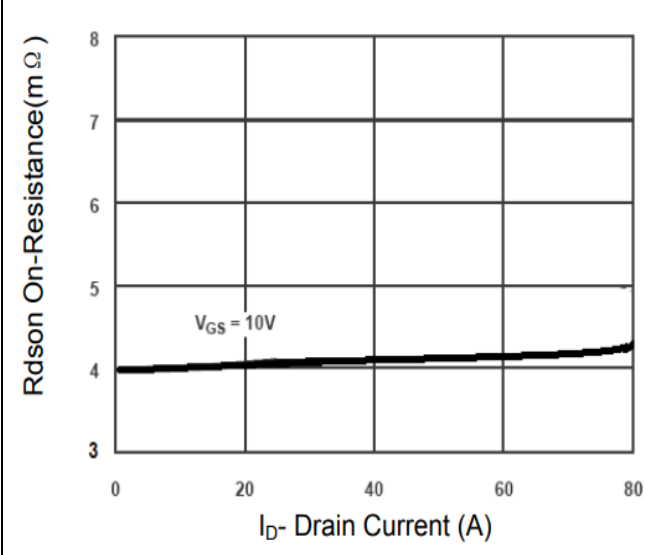

$R_{ds(on)}=f(I_D); V_{GS}=10\text{V}$

Diagram 4: Typ. Rds(on) – Junction Temperature

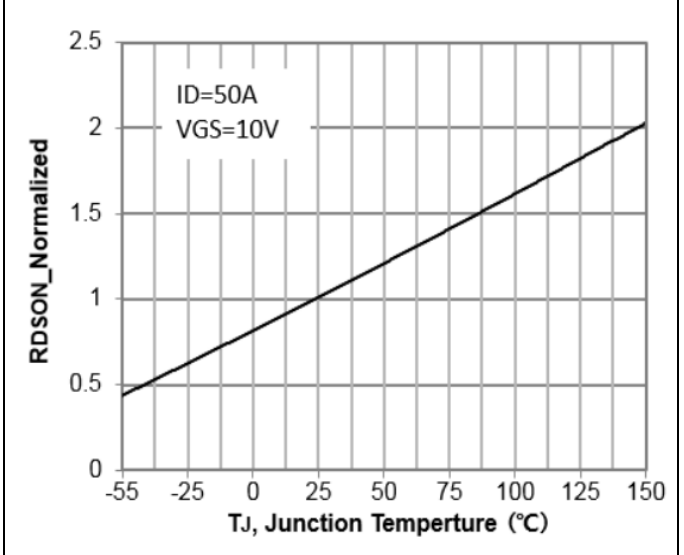

$R_{ds(on)}=f(T_j); V_{GS}=10\text{V}/I_D=50\text{A}$

Diagram 5: Typ. Body-Diode Characteristics

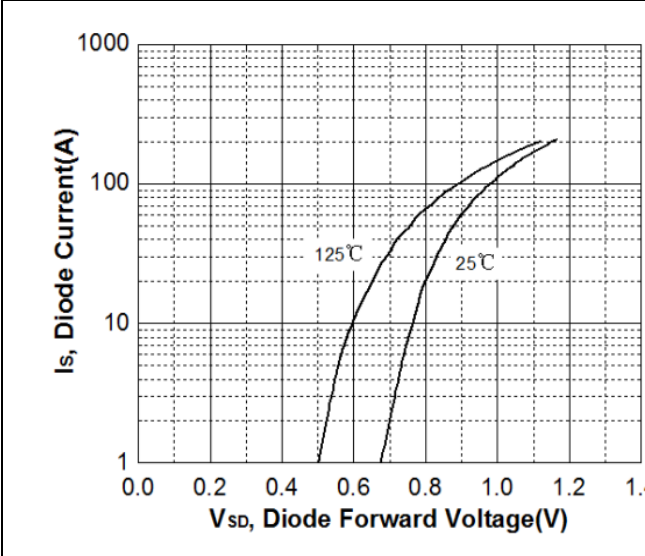

$I_F=f(V_{DS});$ parameter: T_j

Diagram 6: Typ. Capacitance vs. Vds

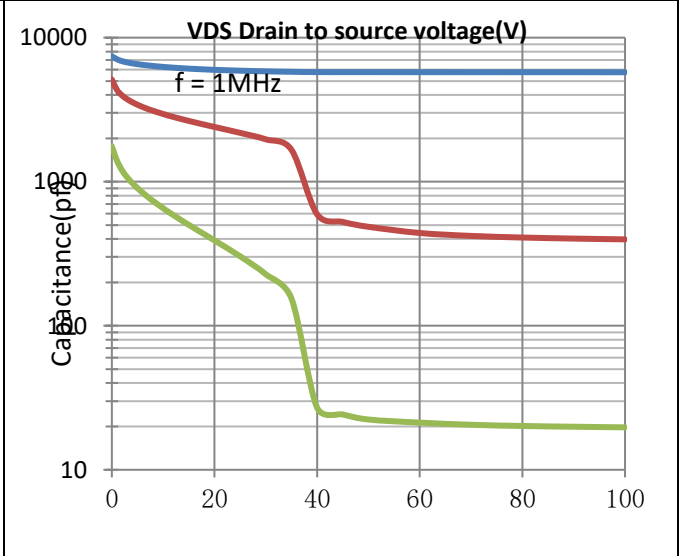

$C=f(V_{DS}); V_{GS}=0\text{V}; f=1\text{MHz}$

Diagram 7: Typ. Power Dissipation

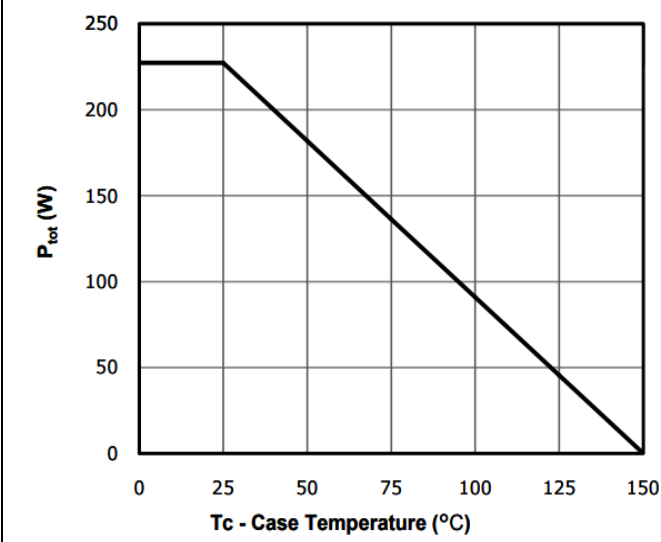

$P_{tot}=f(T_c);$

Diagram 8: Typ. Drain Current De-rating

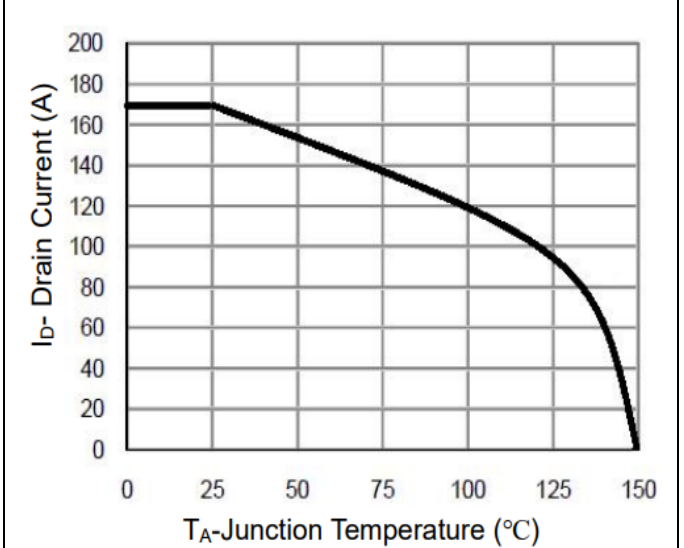

$I_D=f(T_c);$

Diagram 9: Typ. Gate charge

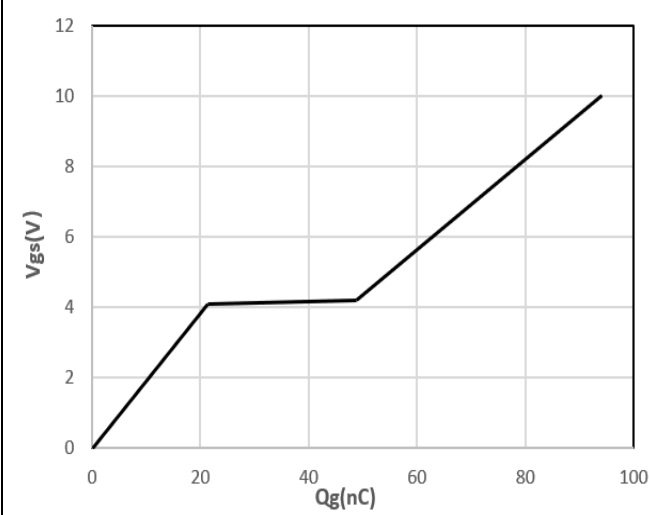

$V_{GS}=f(Q_{gate}); I_D=20A$ pulsed; parameter: V_{DD}

Diagram 10: Typ. Maximum Safe Operating Area

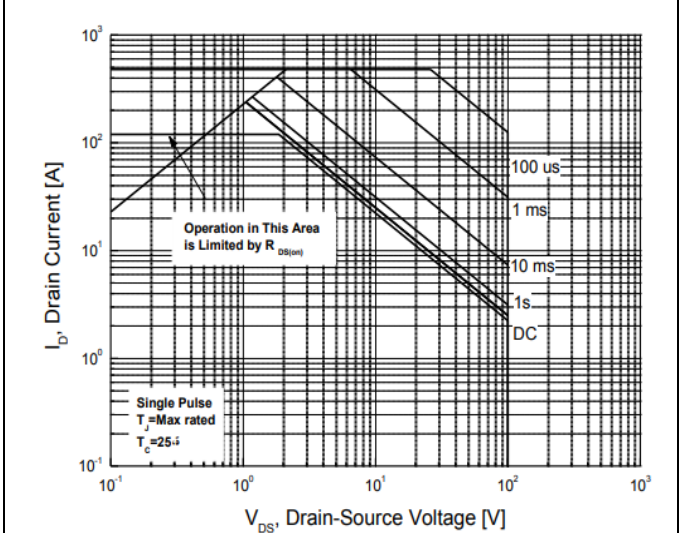

$I_D=f(V_{DS}); T_c=25^\circ C; V_{GS}> 7V; D=0;$ parameter tp

Figure 11 Normalized Maximum Transient Thermal Impedance

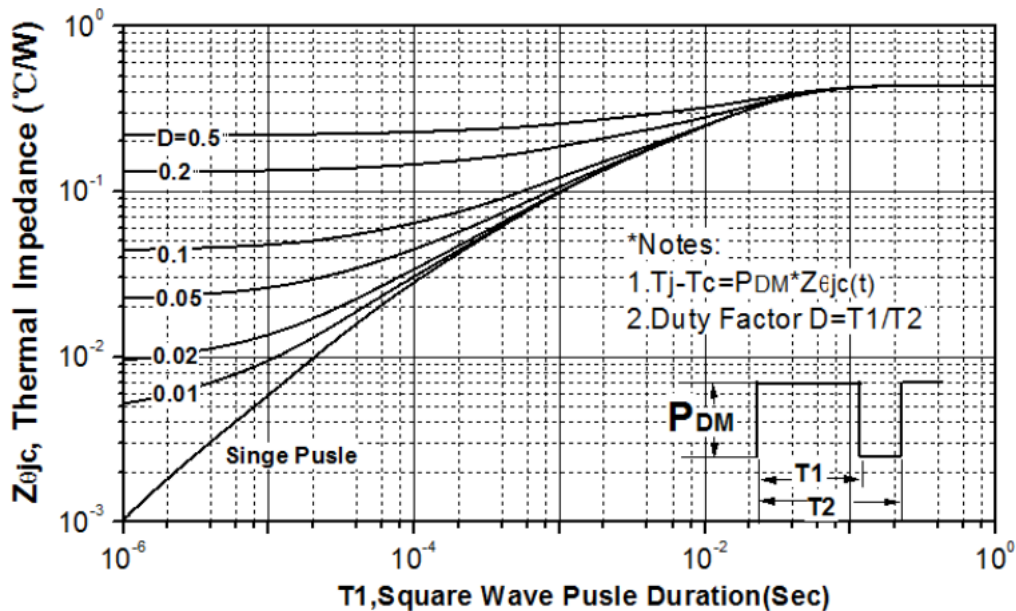

5. Package Outlines

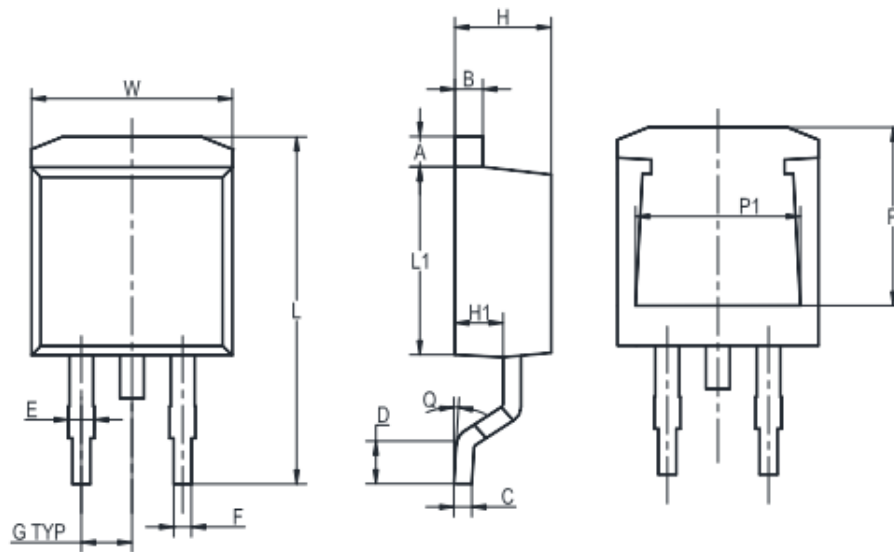

UNIT	A	B	C	D	E	F	G	W	H	H1	L	L1	Q	P	P1
mm	1.5	1.5	0.5	2.60	1.6	0.94	2.54	10.5	4.8	2.9	16.5	8.7	8°	7.6	8.2
	1.1	1.1	0.3	2.15	1.1	0.68	TYP	9.6	4.4	2.5	14.5	8.2	MAX	7.1	7.4

Figure1: Outline PG-T0263(HC&LM)

Revision History

Revision	Date	Subjects (major changes since last revision)
1.0	2023-05-12	Preliminary version

X-ON Electronics

Largest Supplier of Electrical and Electronic Components

Click to view similar products for [MOSFET](#) category:

Click to view products by [ANHI](#) manufacturer:

Other Similar products are found below :

[IRFD120](#) [IRFY240C](#) [JANTX2N5237](#) [2SK2267\(Q\)](#) [BUK455-60A/B](#) [MIC4420CM-TR](#) [VN1206L](#) [NDP4060](#) [SI4482DY](#)
[IPS70R2K0CEAKMA1](#) [SQD23N06-31L-GE3](#) [TK16J60W,S1VQ\(O](#) [2SK2614\(TE16L1,Q\)](#) [DMN1017UCP3-7](#) [EFC2J004NUZTDG](#)
[DMN1053UCP4-7](#) [SQJ469EP-T1-GE3](#) [NTE2384](#) [DMC2700UDMQ-7](#) [DMN2080UCB4-7](#) [DMN61D9UWQ-13](#) [US6M2GTR](#)
[DMN31D5UDJ-7](#) [DMP22D4UFO-7B](#) [DMN1006UCA6-7](#) [DMN16M9UCA6-7](#) [STF5N65M6](#) [IRF40H233XTMA1](#) [STU5N65M6](#)
[DMN6022SSD-13](#) [DMN13M9UCA6-7](#) [DMTH10H4M6SPS-13](#) [DMN2990UFB-7B](#) [IPB80P04P405ATMA2](#) [2N7002W-G](#) [MCAC30N06Y-](#)
[TP](#) [MCQ7328-TP](#) [NTMC083NP10M5L](#) [NVMFS2D3P04M8LT1G](#) [BXP7N65D](#) [BXP4N65F](#) [AOL1454G](#) [WMJ80N60C4](#) [BXP2N20L](#)
[BXP2N65D](#) [BXT1150N10J](#) [BXT1700P06M](#) [TSM60NB380CP](#) [ROG](#) [RQ7L055BGTCR](#) [DMNH15H110SK3-13](#)