

MOSFET Silicon N-Channel MOS



1. Applications

Synchronous rectification in SMPS,
Hard switching and High speed circuit
DC/DC in telecoms and industrial

2. Features

Low drain-source on-resistance: $R_{DS(ON)} = 5.6m\Omega$ (typ.)
High speed power switching
Enhanced body diode dv/dt capability
Enhanced avalanche ruggedness



Table 1 Key Performance Parameters

Parameter	Value	Unit
$V_{DS} @ T_{j,max}$	80	V
$R_{DS(on),max}$	6.0	m Ω
$Q_{g,typ}$	55.7	nC
$I_{D,pulse}$	240	A

3. Packaging and Internal Circuit

Part Name	Package	Marking
AUA060N08AG	TO220F	AUA060N08AG
AUB060N08AG	TO263	AUB060N08AG
AUP060N08AG	TO220	AUP060N08AG
AUN060N08AG	DFN5x6	AUN060N08AG
AUD060N08AG	TO252	AUD060N08AG

TO220F	TO263	TO220	TO252	DFN5x6

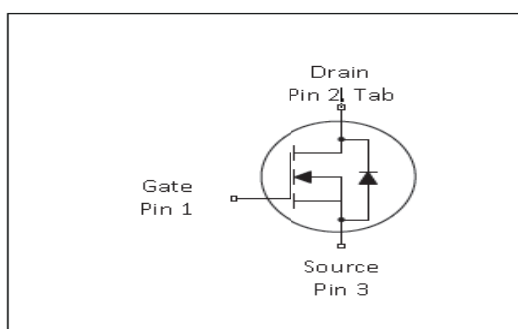

1 Maximum ratings

At $T_j = 25^\circ\text{C}$, unless otherwise specified

Table 2 Maximum ratings

Parameter	Symbol	Values			Unit	Note / Test Condition
		Min.	Typ.	Max.		
Continuous drain current ¹⁾	I_D		-	60	A	$T_C = 25^\circ\text{C}$
Pulsed drain current ²⁾	$I_{D,pulse}$	-		240	A	$T_C = 25^\circ\text{C}$
Avalanche energy, single pulse	E_{AS}	-	-	300	mJ	
Gate source voltage (static)	V_{GS}	-20	-	20	V	static;
Power dissipation (TO220F)	P_{tot}	-	-	30	W	$T_C = 25^\circ\text{C}$
Power dissipation (TO263&TO220&TO252)	P_{tot}	-	-	150	W	$T_C = 25^\circ\text{C}$
Power dissipation (DFN5x6)	P_{tot}	-	-	74	W	$T_C = 25^\circ\text{C}$
Storage temperature	T_{stg}	-55	-	175	$^\circ\text{C}$	
Operating junction temperature	T_j	-55	-	175	$^\circ\text{C}$	

¹⁾ Limited by $T_{j,max}$. Maximum Duty Cycle $D = 0.50$

²⁾ Pulse width t_p limited by $T_{j,max}$

³⁾ Identical low side and high side switch with identical R_g

2 Thermal characteristics

Table 3 Thermal characteristics(TO220F)

Parameter	Symbol	Values			Unit	Note / Test Condition
		Min.	Typ.	Max.		
Thermal resistance, junction - case	R_{thJC}	-	-	5	°C/W	-
Thermal resistance, junction - ambient	R_{thJA}	-	-	60	°C/W	device on PCB, minimal footprint

Table Thermal characteristics(TO263&TO220&TO252)

Parameter	Symbol	Values			Unit	Note / Test Condition
		Min.	Typ.	Max.		
Thermal resistance, junction - case	R_{thJC}	-	-	1	°C/W	-
Thermal resistance, junction - ambient	R_{thJA}	-	-	62	°C/W	device on PCB, minimal footprint

Table Thermal characteristics(DFN5x6)

Parameter	Symbol	Values			Unit	Note / Test Condition
		Min.	Typ.	Max.		
Thermal resistance, junction - case	R_{thJC}	-	-	1.7	°C/W	-
Thermal resistance, junction - ambient	R_{thJA}	-	-	50	°C/W	device on PCB, minimal footprint

3 Electrical characteristics

at $T_j=25^\circ\text{C}$, unless otherwise specified

Table 4 Static characteristics

Parameter	Symbol	Values			Unit	Note / Test Condition
		Min.	Typ.	Max.		
Drain-source breakdown voltage	$V_{(BR)DSS}$	80	-	-	V	$V_{GS}=0V, I_D=10mA$
Gate threshold voltage	$V_{(GS)th}$	2.5		3.4	V	$V_{DS}=V_{GS}, I_D=250\mu A$
Zero gate voltage drain current	I_{DSS}	-	-	1000	nA	$V_{DS}=80V, V_{GS}=0V, T_j=25^\circ\text{C}$
Gate-source leakage current	I_{GSS}	-	-	100	nA	$V_{GS}=20V, V_{DS}=0V$
Drain-source on-state resistance	$R_{DS(on)}$	-	5.4	6.0	m Ω	$V_{GS}=10V, I_D=20A, T_j=25^\circ\text{C}$
Gate resistance (Intrinsic)	R_G	-	1.2	-	Ω	$f=1MHz, \text{open drain}$

Table 5 Dynamic characteristics

Parameter	Symbol	Values			Unit	Note / Test Condition
		Min.	Typ.	Max.		
Input capacitance	C_{iss}	-	3730	-	pF	$V_{ds}=40V, V_{gs}=0V$ $f=1MHz$
Output capacitance	C_{oss}	-	674	-	pF	$V_{ds}=40V, V_{gs}=0V$ $f=1MHz$
Reverse transfer capacitance	C_{rss}	-	24.24	-	pF	$V_{ds}=40V, V_{gs}=0V$ $f=1MHz$
Turn-on delay time	$t_{d(on)}$	-	16.5	-	ns	$V_{DD}=40V, V_{GS}=10V, R_G=10\Omega$ $I_D=20A$
Rise time	t_r	-	13.7	-	ns	$V_{DD}=40V, V_{GS}=10V, R_G=10\Omega$ $I_D=20A$
Turn-off delay time	$t_{d(off)}$	-	35.9	-	ns	$V_{DD}=40V, V_{GS}=10V, R_G=10\Omega$ $I_D=20A$
Fall time	t_f	-	13.45	-	ns	$V_{DD}=40V, V_{GS}=10V, R_G=10\Omega$ $I_D=20A$

Table 6 Gate charge characteristics

Parameter	Symbol	Values			Unit	Note / Test Condition
		Min.	Typ.	Max.		
Gate to source charge	Q_{gs}	-	15.9	-	nC	$V_{DS}=40V, V_{GS}=0 \text{ to } 10V$ $I_D=20A$
Gate to drain charge	Q_{gd}	-	13.3	-	nC	$V_{DS}=40V, V_{GS}=0 \text{ to } 10V$ $I_D=20A$
Gate charge total	Q_g	-	55.7	-	nC	$V_{DS}=40V, V_{GS}=0 \text{ to } 10V$ $I_D=20A$

Table 7 Reverse diode characteristics

Parameter	Symbol	Values			Unit	Note / Test Condition
		Min.	Typ.	Max.		
Diode forward voltage	V_{SD}	-	0.7	-	V	$V_{GS}=0V, I_F=1A, T_J=25^{\circ}C$
Reverse recovery time	t_{rr}	-	40.9	-	ns	$V_R=40V, I_F=20A, diF/dt=200A/us$
Reverse recovery charge	Q_{rr}	-	106.8	-	uC	$V_R=40V, I_F=20A, diF/dt=200A/us$
Peak reverse recovery current	I_{rrm}	-	-3.7	-	A	$V_R=40V, I_F=20A, diF/dt=200A/us$

4 Package Outlines

TO-220F

单位: mm

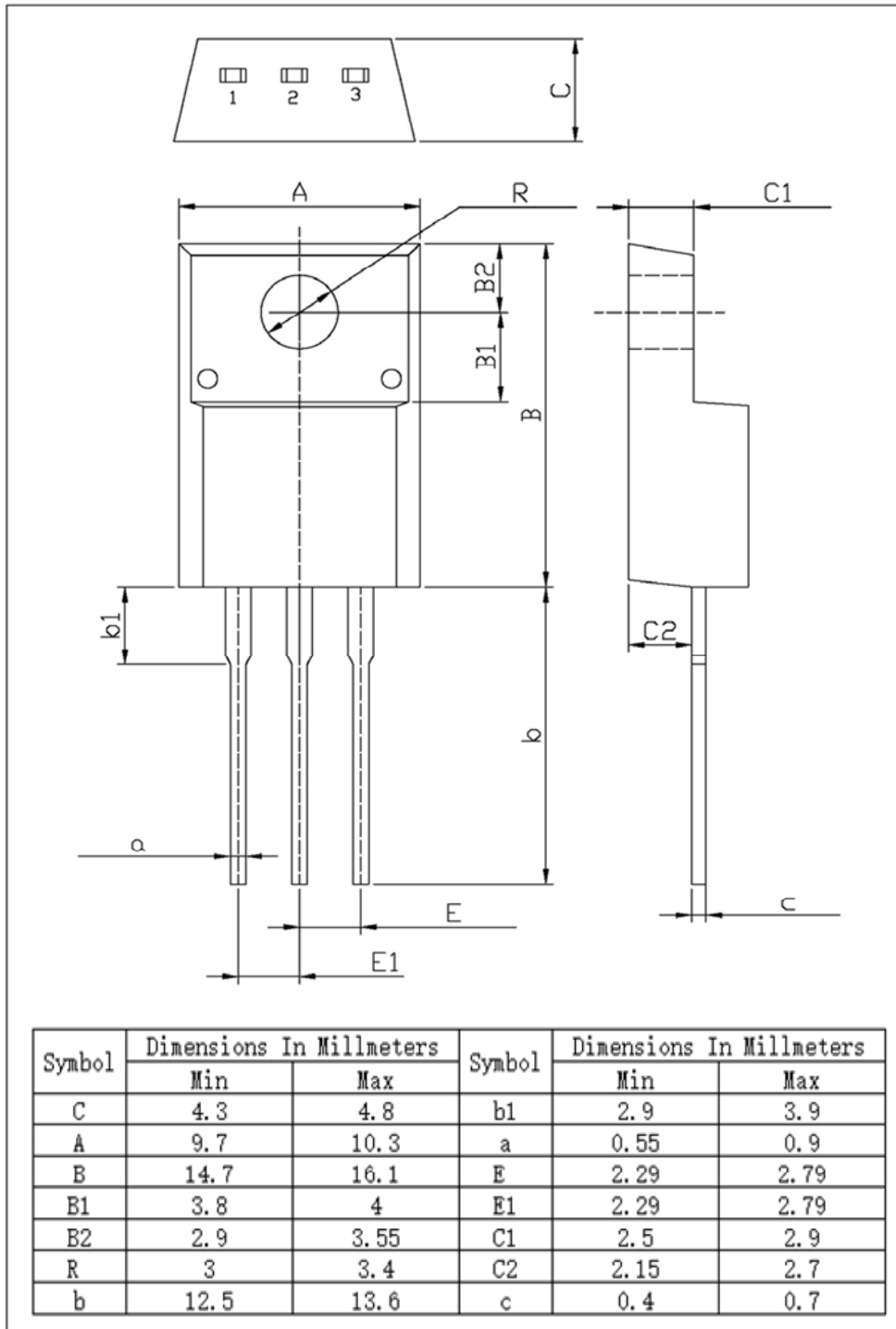

Figure1: Outline PG-TO220F

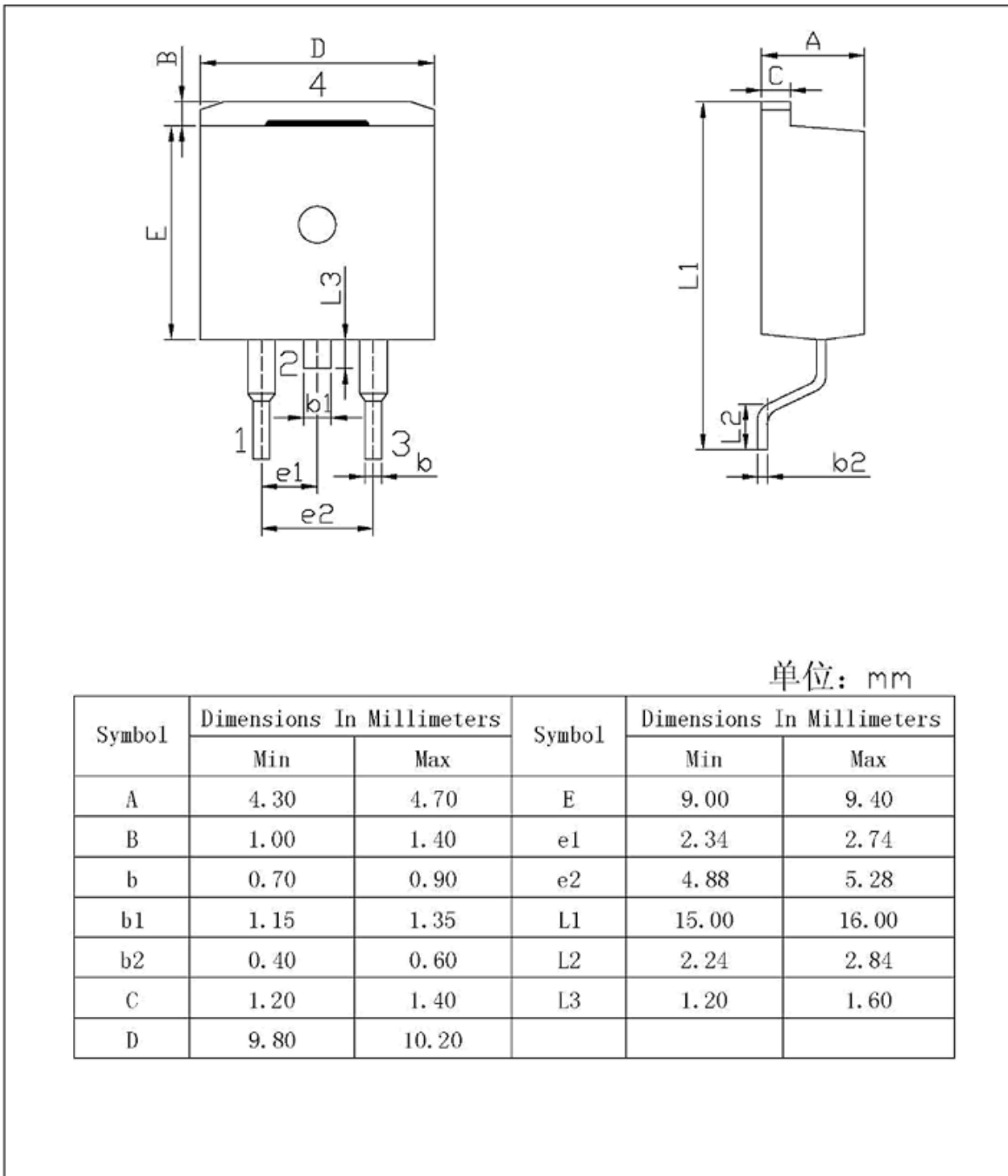

Figure2: Outline PG-T0263

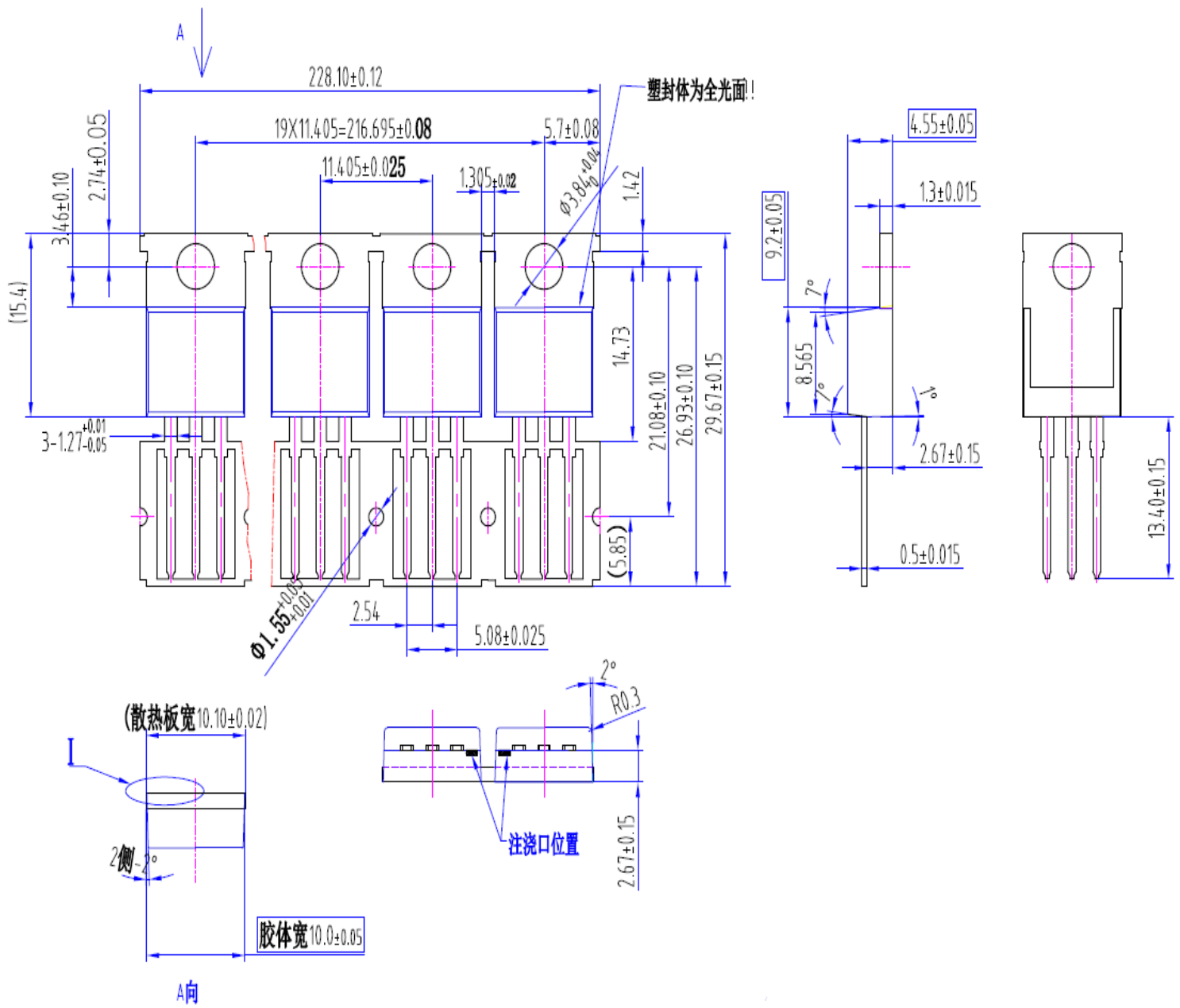
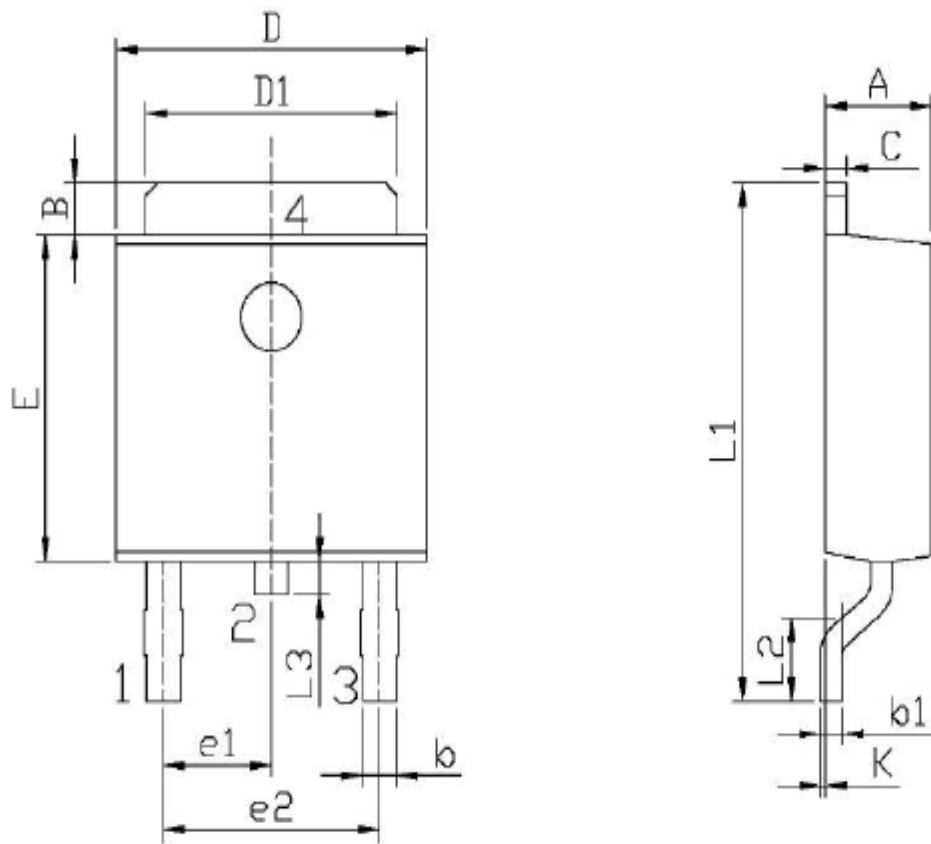

Figure3: Outline PG-T0220



单位: mm

Symbol	Dimensions In Millimeters		Symbol	Dimensions In Millimeters	
	Min	Max		Min	Max
A	2.20	2.40	E	5.95	6.25
B	0.95	1.25	e1	2.24	2.34
b	0.50	0.70	e2	4.43	4.73
b1	0.45	0.55	L1	9.45	9.95
C	0.45	0.55	L2	1.25	1.75
D	6.45	6.75	L3	0.60	0.90
D1	5.10	5.50	K	0.00	0.10

Figure4: OutlinePG-T0252

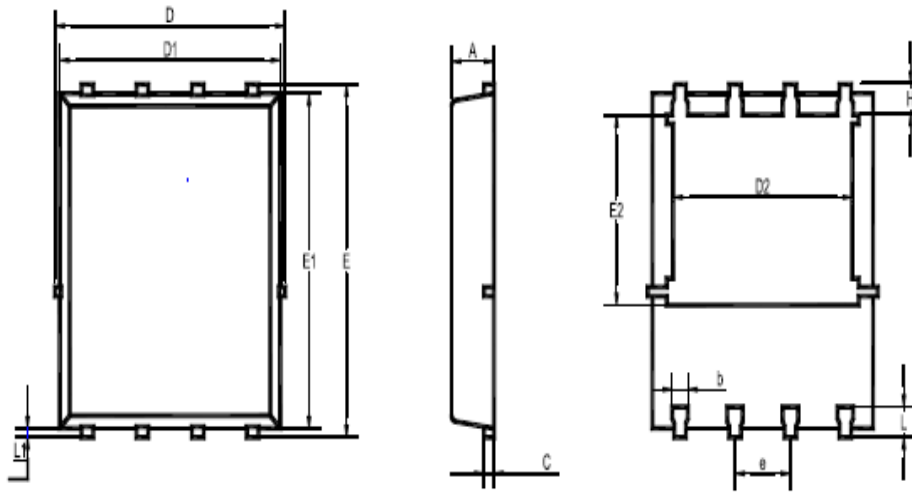

UNIT	A	b	C	D	D1	D2	E	E1	E2	e	L	L1	H
mm	1.12	0.51	0.34	5.26	5.1	4.5	6.25	6	3.66	1.37	0.71	0.2	0.71
	0.9	0.33	0.11	4.7	4.7	3.56	5.75	5.6	3.18	1.17	0.35	0.06	0.35

Recommended Soldering Footprint

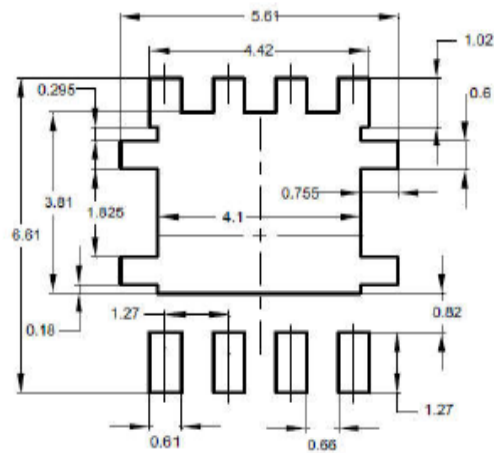

Figure5: Outline PG-DFN5x6

Revision History

Revision	Date	Subjects (major changes since last revision)
1.0	2021-01-21	Preliminary version
1.1	2021-02-04	Add package for TO263&TO220&DFN5x6&TO252

X-ON Electronics

Largest Supplier of Electrical and Electronic Components

Click to view similar products for [MOSFET](#) category:

Click to view products by [ANHI](#) manufacturer:

Other Similar products are found below :

[IRFD120](#) [IRFY240C](#) [JANTX2N5237](#) [BUK455-60A/B](#) [MIC4420CM-TR](#) [VN1206L](#) [NDP4060](#) [SI4482DY](#) [IPS70R2K0CEAKMA1](#)
[SQD23N06-31L-GE3](#) [TK16J60W,S1VQ\(O](#) [2SK2614\(TE16L1,Q\)](#) [DMN1017UCP3-7](#) [EFC2J004NUZTDG](#) [DMN1053UCP4-7](#) [SQJ469EP-](#)
[T1-GE3](#) [NTE2384](#) [DMC2700UDMQ-7](#) [DMN2080UCB4-7](#) [DMN61D9UWQ-13](#) [US6M2GTR](#) [DMN31D5UDJ-7](#) [DMP22D4UFO-7B](#)
[DMN1006UCA6-7](#) [DMN16M9UCA6-7](#) [STF5N65M6](#) [IRF40H233XTMA1](#) [STU5N65M6](#) [DMN6022SSD-13](#) [DMN13M9UCA6-7](#)
[DMTH10H4M6SPS-13](#) [DMN2990UFB-7B](#) [IPB80P04P405ATMA2](#) [2N7002W-G](#) [MCAC30N06Y-TP](#) [MCQ7328-TP](#) [NTMC083NP10M5L](#)
[NVMFS2D3P04M8LT1G](#) [BXP7N65D](#) [BXP4N65F](#) [AOL1454G](#) [WMJ80N60C4](#) [BXP2N20L](#) [BXP2N65D](#) [BXT1150N10J](#) [BXT1700P06M](#)
[TSM60NB380CP](#) [ROG](#) [RQ7L055BGTCR](#) [DMNH15H110SK3-13](#) [SLF10N65ABV2](#)