

MOSFET Silicon N-Channel MOS



1. Applications

Single-ended flyback or two-transistor forward topologies.
PC power, PD Adaptor, LCD & PDP TV and LED lighting.

2. Features

Low drain-source on-resistance:
DFN5x6 $R_{DS(ON)} = 3.3m\Omega$ (typ.)
TO220&220F&263 $R_{DS(ON)} = 3.6m\Omega$ (typ.)
Easy to control Gate switching
Enhancement mode: $V_{th} = 1.2$ to 2.5 V

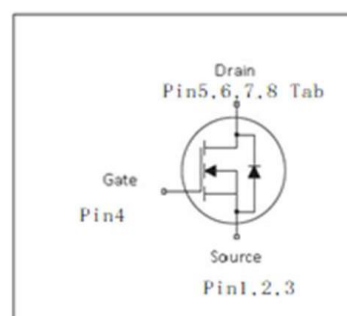
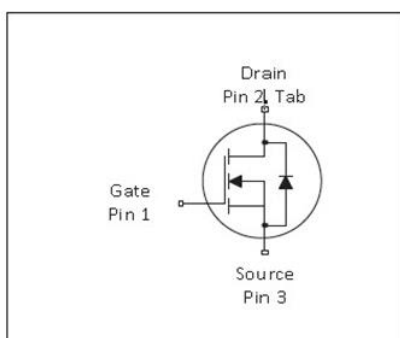
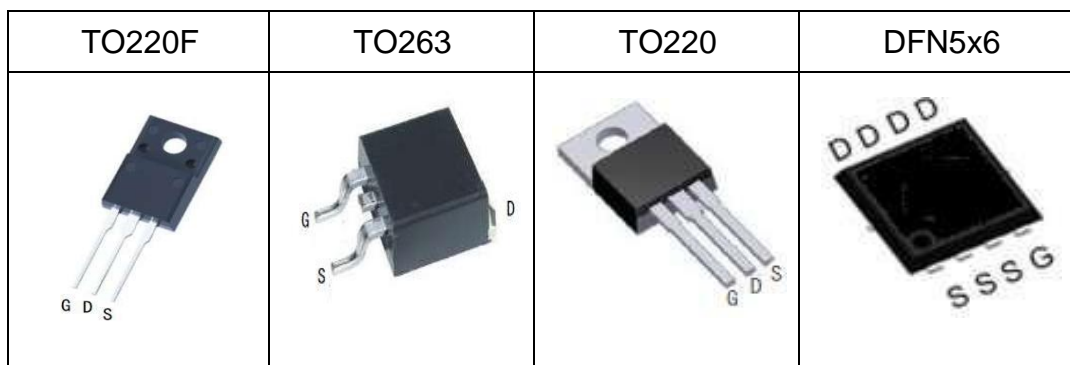

Table 1 Key Performance Parameters

Parameter	Value	Unit
$V_{DS} @ T_{j,max}$	100	V
$R_{DS(on),max}$ DFN5X6	3.6	m Ω
$R_{DS(on),max}$ TO220	3.9	m Ω
Q_g,typ	65	nC
$I_{D,pulse}$	437	A

3. Packaging and Internal Circuit

Part Name	Package	Marking
AUN036N10	DFN5X6	AUN036N10
AUP039N10	TO220	AUP039N10
AUA039N10	TO220F	AUA039N10
AUB039N10	TO263	AUB039N10



1 Maximum ratings

at $T_j = 25^\circ\text{C}$, unless otherwise specified

Table 2 Maximum ratings

Parameter	Symbol	Values			Unit	Note / Test Condition
		Min.	Typ.	Max.		
Continuous drain current ¹⁾	I_D		-	125	A	$T_C=25^\circ\text{C}$
Pulsed drain current ²⁾	$I_{D,pulse}$	-	-	437	A	$T_C=25^\circ\text{C}$
Avalanche energy, single pulse	E_{AS}	-	-	306	mJ	$T_C=25^\circ\text{C}$, $V_{DD}=50\text{V}$, $I=35\text{A}$, $L=0.1\text{mH}$, $R_G=25\Omega$
Avalanche current, single pulse	I_{AR}	-	-	35	A	$T_C=25^\circ\text{C}$, $V_{DD}=50\text{V}$, $L=0.1\text{mH}$, $R_G=25\Omega$
Gate source voltage (static)	V_{GS}	-20	-	20	V	static;
Power dissipation(TO220&263)	P_{tot}	-	-	151	W	$T_C=25^\circ\text{C}$
Power dissipation (TO220F)	P_{tot}	-	-	30	W	$T_C=25^\circ\text{C}$
Power dissipation (DFN5X6)	P_{tot}	-	-	75	W	$T_C=25^\circ\text{C}$
Storage temperature	T_{stg}	-55	-	150	$^\circ\text{C}$	
Operating junction temperature	T_j	-55	-	150	$^\circ\text{C}$	
Soldering Temperature Distance of 1.6mm from case for 10s	T_L			260	$^\circ\text{C}$	

¹⁾ Limited by $T_{j,max}$. Maximum Duty Cycle $D = 0.50$

²⁾ Pulse width t_p limited by $T_{j,max}$

³⁾ Identical low side and high side switch with identical R_G

2 Thermal characteristics

Table 3 Thermal characteristics (TO220F)

Parameter	Symbol	Values			Unit	Note / Test Condition
		Min.	Typ.	Max.		
Thermal resistance, junction - case	R_{thJC}	-	-	4.2	°C/W	-
Thermal resistance, junction - ambient	R_{thJA}	-	-	60	°C/W	device on PCB, minimal footprint

Table Thermal characteristics (TO263&TO220)

Parameter	Symbol	Values			Unit	Note / Test Condition
		Min.	Typ.	Max.		
Thermal resistance, junction - case	R_{thJC}	-	-	0.83	°C/W	-
Thermal resistance, junction - ambient	R_{thJA}	-	-	62	°C/W	device on PCB, minimal footprint

Table Thermal characteristics (DFN5x6)

Parameter	Symbol	Values			Unit	Note / Test Condition
		Min.	Typ.	Max.		
Thermal resistance, junction - case	R_{thJC}	-	-	1.7	°C/W	-
Thermal resistance, junction - ambient	R_{thJA}	-	-	50	°C/W	device on PCB, minimal footprint

3 Electrical characteristics

at $T_j=25^{\circ}\text{C}$, unless otherwise specified

Table 4 Static characteristics

Parameter	Symbol	Values			Unit	Note / Test Condition
		Min.	Typ.	Max.		
Drain-source breakdown voltage	$V_{(BR)DSS}$	100	-	-	V	$V_{GS}=0V, I_D=250\mu A$
Gate threshold voltage	$V_{(GS)th}$	1.2	1.8	2.5	V	$V_{DS}=V_{GS}, I_D=250\mu A$
Zero gate voltage drain current	I_{DSS}	-	-	1	μA	$V_{DS}=80V, V_{GS}=0V, T_j=25^{\circ}\text{C}$
Gate-source leakage current	I_{GSS}	-	-	± 100	nA	$V_{GS}=\pm 20V, V_{DS}=0V$
Drain-source on-state resistance DFN5x6	$R_{DS(on)}$	-	3.3	3.6	m Ω	$V_{GS}=10V, I_D=20A, T_j=25^{\circ}\text{C}$
Drain-source on-state resistance TO220&220F&263	$R_{DS(on)}$	-	3.6	3.9	m Ω	$V_{GS}=10V, I_D=20A, T_j=25^{\circ}\text{C}$
Gate resistance (Intrinsic)	R_G	-	0.6	-	Ω	$f=1\text{MHz}$, open drain

Table 5 Dynamic characteristics(by calculating)

Parameter	Symbol	Values			Unit	Note / Test Condition
		Min.	Typ.	Max.		
Input capacitance	C_{iss}	-	3562	-	PF	$V_{GS}=0V, V_{DS}=50V, f=1\text{MHz}$
Output capacitance	C_{oss}	-	865	-	PF	$V_{GS}=0V, V_{DS}=50V, f=1\text{MHz}$
Reverse transfer capacitance	C_{rss}	-	83	-	PF	$V_{GS}=0V, V_{DS}=50V, f=1\text{MHz}$
Turn-on delay time	$t_{d(on)}$	-	29	-	ns	$V_{DD}=50V, V_{GS}=10V, I_D=20A, R_G=10\Omega$
Rise time	t_r	-	55	-	ns	$V_{DD}=50V, V_{GS}=10V, I_D=20A, R_G=10\Omega$
Turn-off delay time	$t_{d(off)}$	-	69	-	ns	$V_{DD}=50V, V_{GS}=10V, I_D=20A, R_G=10\Omega$
Fall time	t_f	-	43	-	ns	$V_{DD}=50V, V_{GS}=10V, I_D=20A, R_G=10\Omega$

Table 6 Gate charge characteristics(by calculating)

Parameter	Symbol	Values			Unit	Note / Test Condition
		Min.	Typ.	Max.		
Gate to source charge	Q_{gs}	-	15.5	-	nC	$V_{DD}=50V, I_D=20A, V_{GS}=0$ to 10V
Gate to drain charge	Q_{gd}	-	17.6	-	nC	$V_{DD}=50V, I_D=20A, V_{GS}=0$ to 10V
Gate charge total	Q_g	-	60.7	-	nC	$V_{DD}=50V, I_D=20A, V_{GS}=0$ to 10V

Table 7 Reverse diode characteristics(by calculating)

Parameter	Symbol	Values			Unit	Note / Test Condition
		Min.	Typ.	Max.		
Diode forward voltage	V_{SD}	-	0.7	-	V	$V_{GS}=0V, I_F=1A, T_J=25^{\circ}C$
Reverse recovery time	t_{rr}	-	45	-	ns	$V_R=30V, I_F=20A, di/dt=300A/\mu s$
Reverse recovery charge	Q_{rr}	-	212	-	nC	$V_R=30V, I_F=20A, di/dt=300A/\mu s$
Peak reverse recovery current	I_{rrm}	-	8.4	-	A	$V_R=30V, I_F=20A, di/dt=300A/\mu s$

4 Electrical characteristics diagram

Diagram 1: Typ. Output characteristics

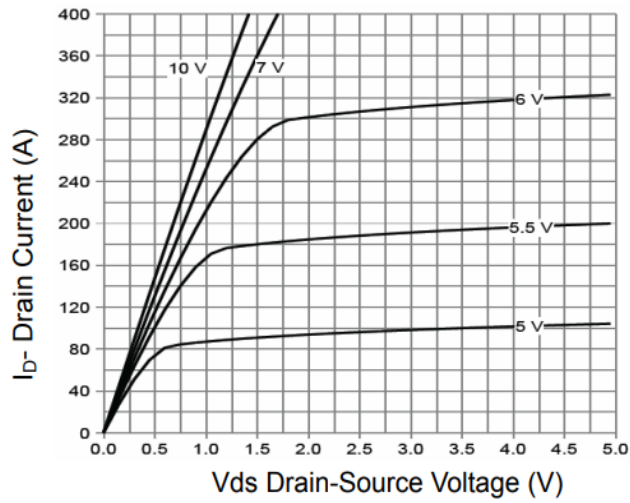

Diagram 2: Typ. Transfer characteristics

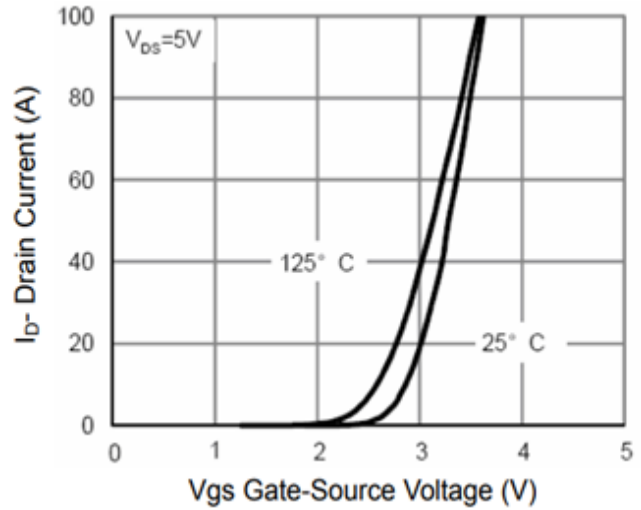

Diagram 3: Typ. Rds(on) vs. Drain Current

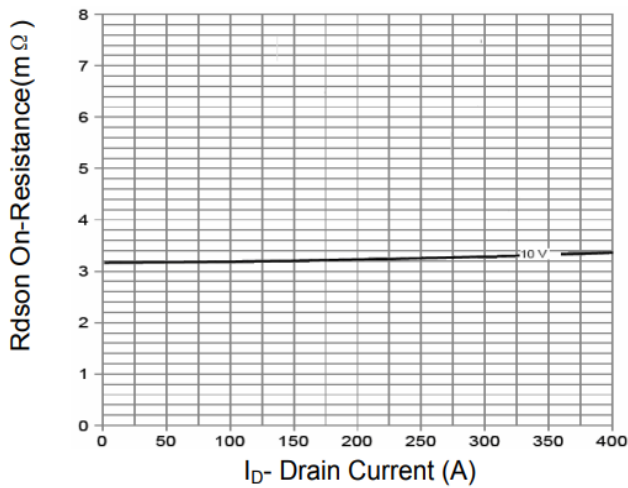

Diagram 4: Typ. Rds(on) – Junction Temperature

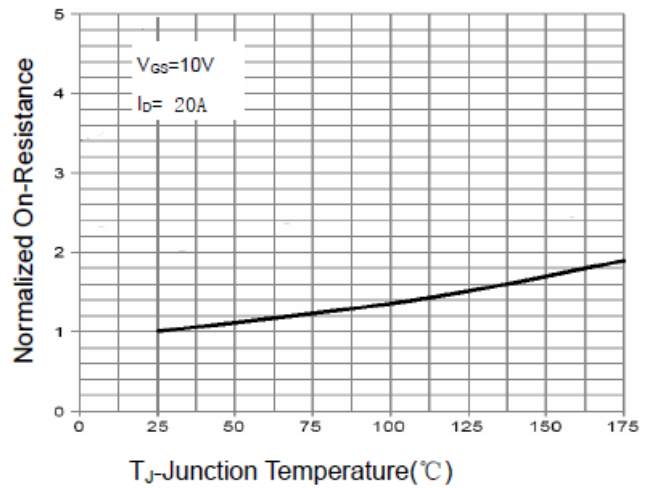

Diagram 5: Typ. Body-Diode Characteristics

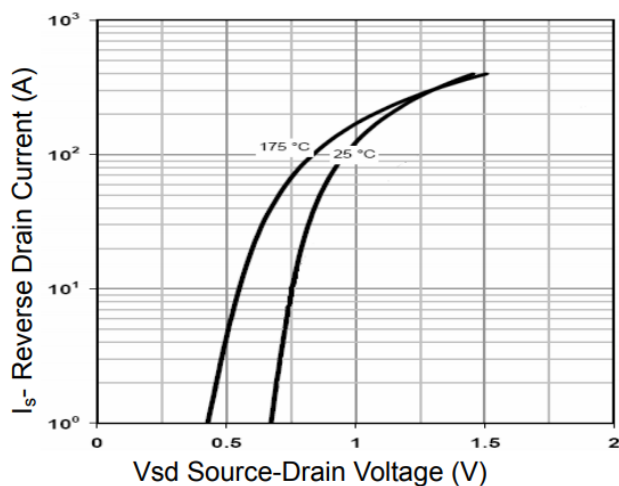

Diagram 6: Typ. Capacitance vs. Vds

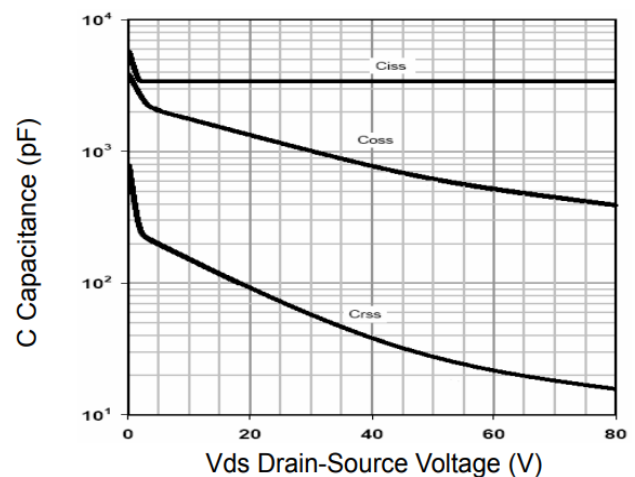

Diagram 7: Typ. Power Dissipation

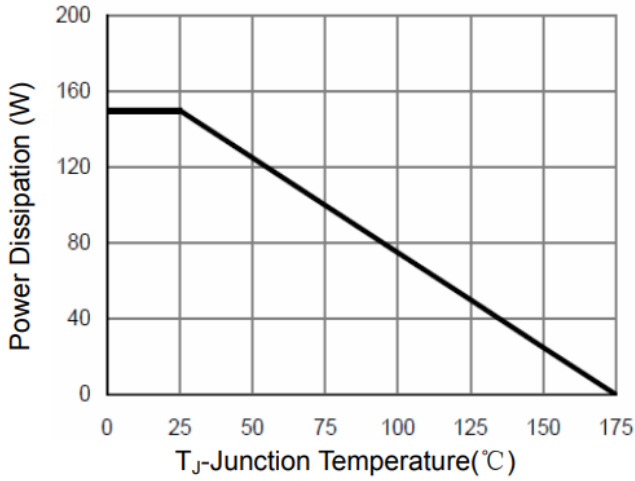

Diagram 8: Typ. Drain Current De-rating

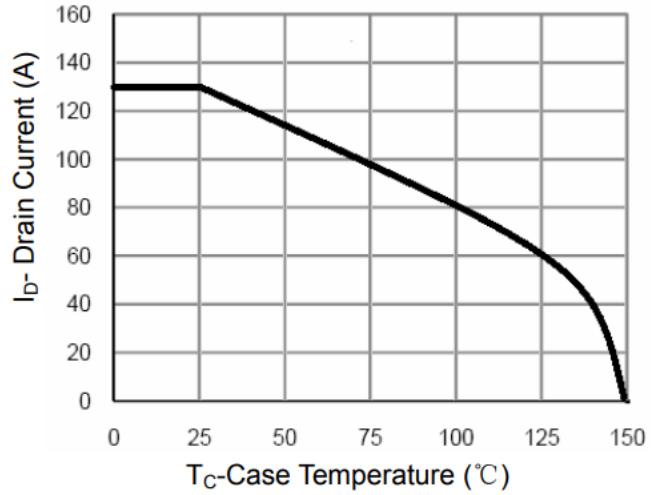

Diagram 9: Typ. Gate charge

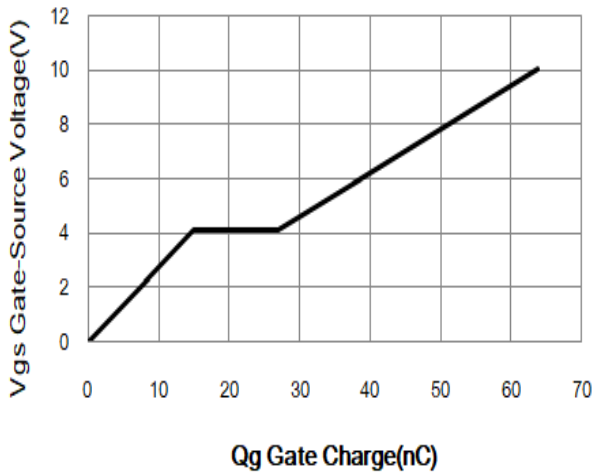

Diagram 10: Typ. Maximum Safe Operating Area

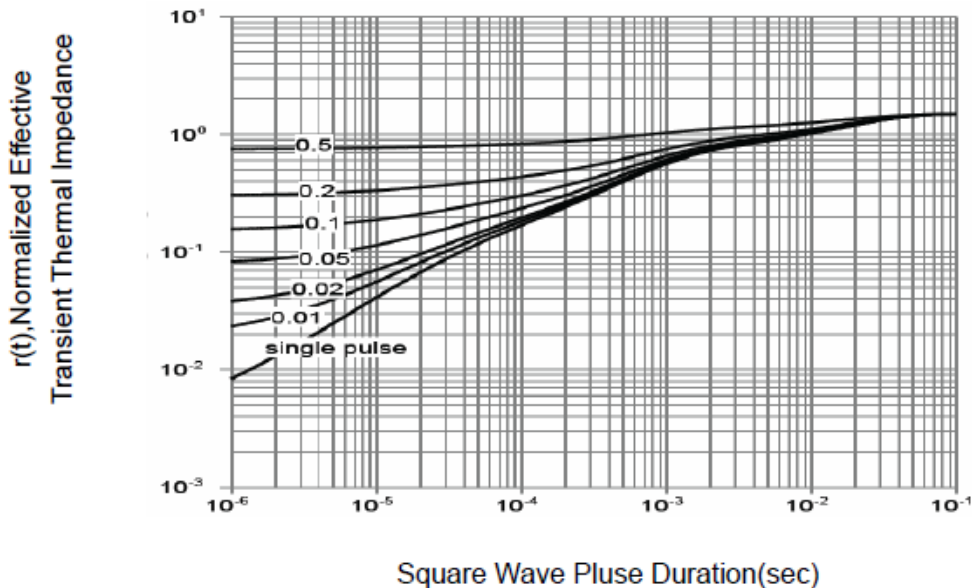
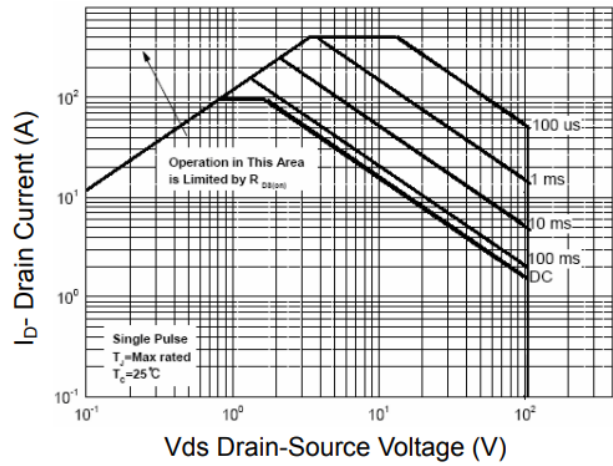

Figure 11 Normalized Maximum Transient Thermal Impedance

5 Test Circuits

Table 8 Diode characteristics

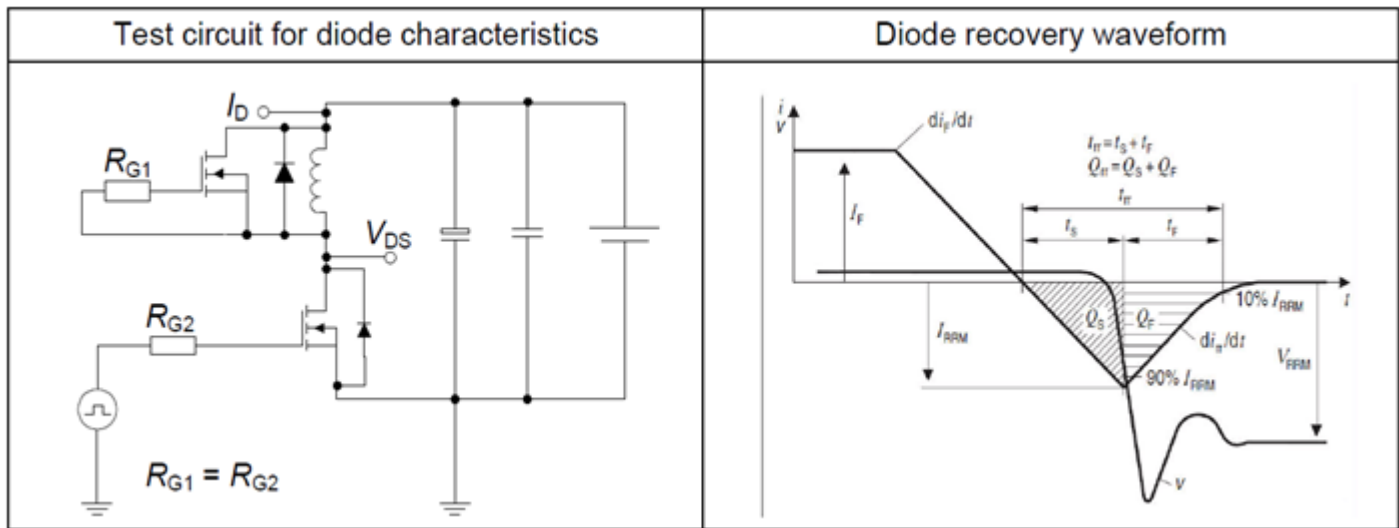

Table 9 Switching times

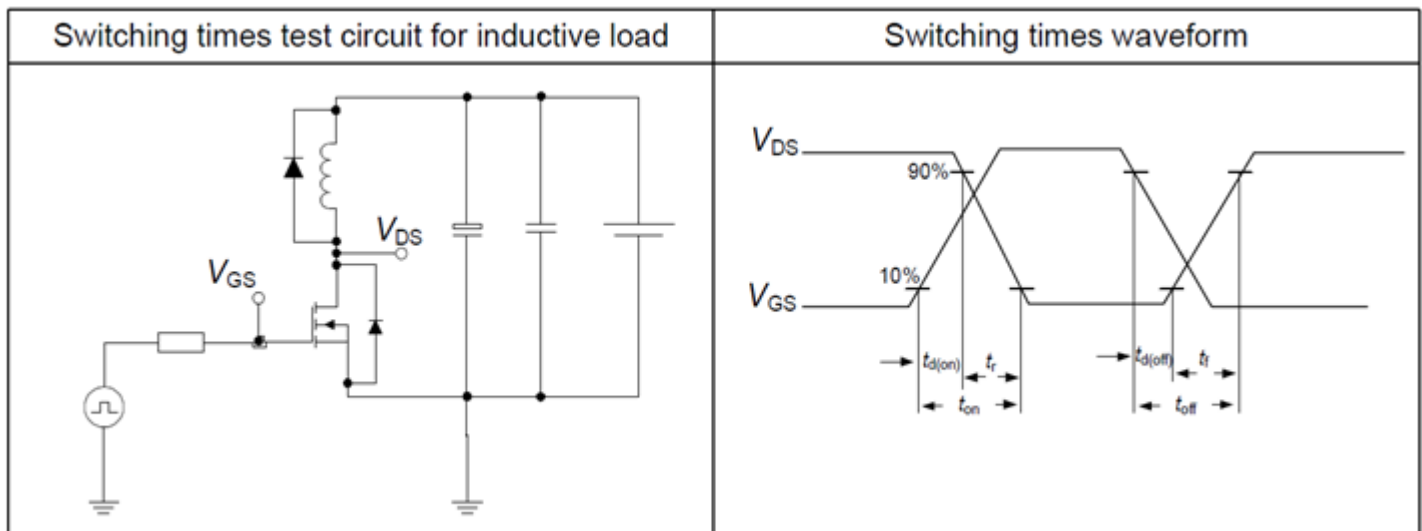
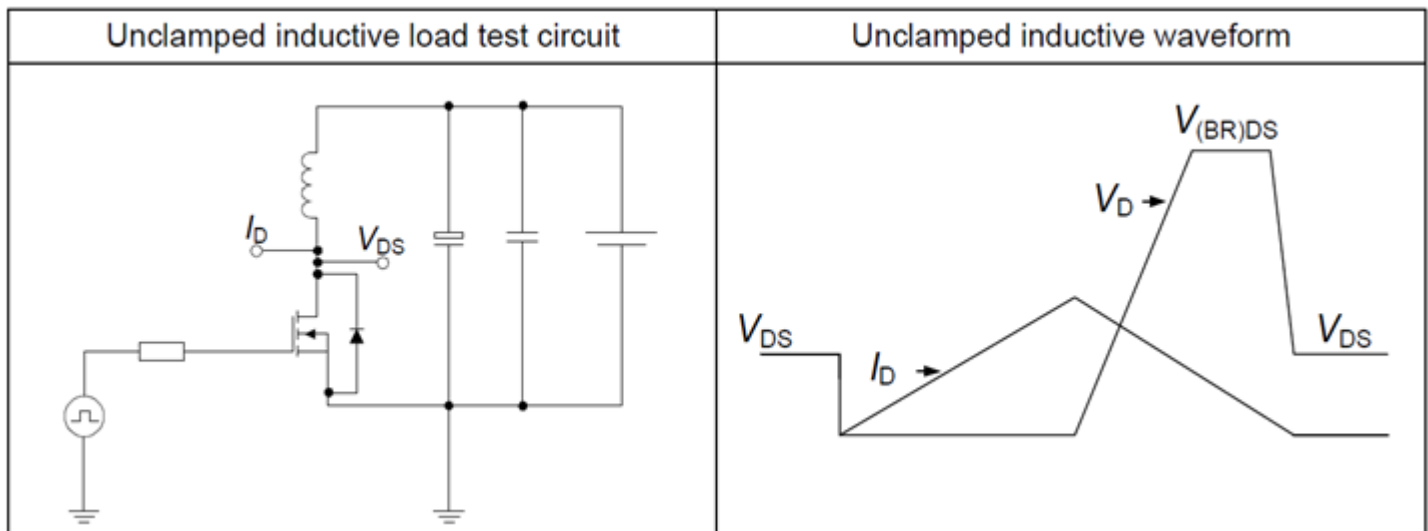
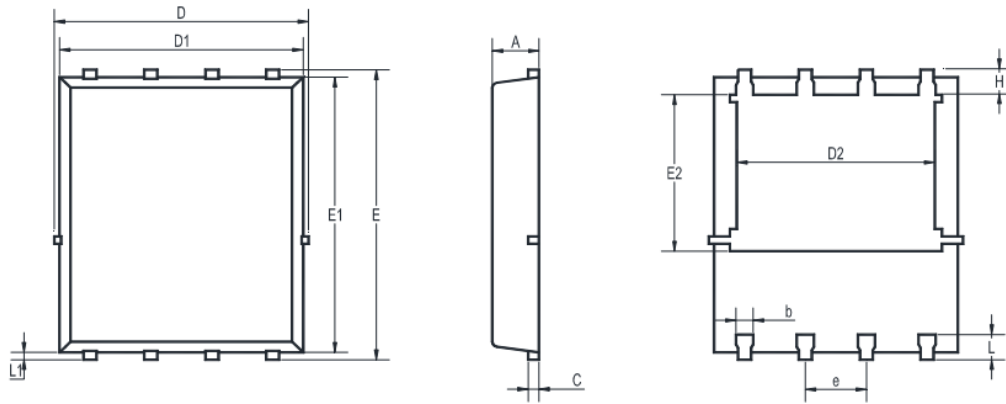

Table 10 Unclamped inductive load



6 Package Outlines



UNIT	A	b	C	D	D1	D2	E	E1	E2	e	L	L1	H
mm	1.12	0.51	0.34	5.26	5.1	4.5	6.25	6	3.66	1.37	0.71	0.2	0.71
	0.9	0.33	0.11	4.7	4.7	3.56	5.75	5.6	3.18	1.17	0.35	0.06	0.35

Figure1: Outline PG-DFN5X6(HC)

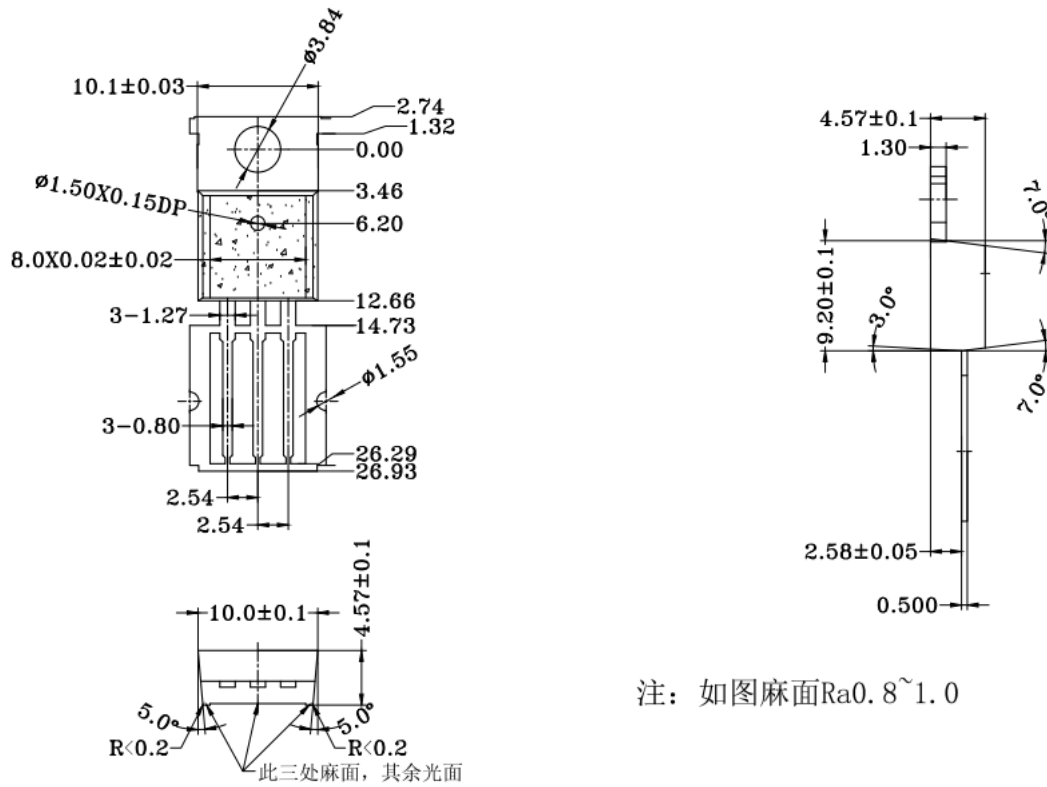

注：如图麻面Ra0.8~1.0

Figure2: Outline PG-T0220(HT)

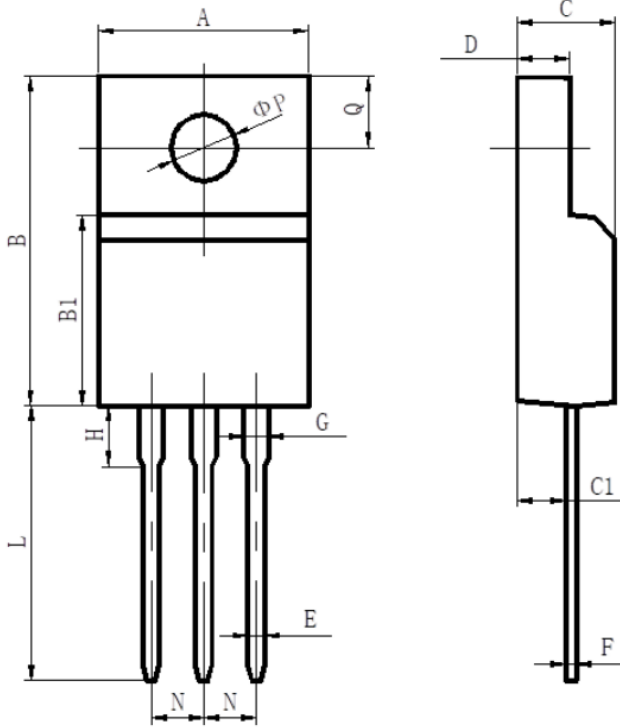

项目	规范(mm)	
	MIN	MAX
A	9.70	10.30
B	15.50	16.10
B1	8.99	9.39
C	4.40	4.80
C1	2.15	2.55
D	2.50	2.90
E	0.70	0.90
F	0.40	0.60
G	1.12	1.42
H	3.40	3.80
L	12.6	13.6
N	2.34	2.74
Q	3.15	3.55
ΦP	3.00	3.30

Figure3: Outline PG-TO220F(HT)

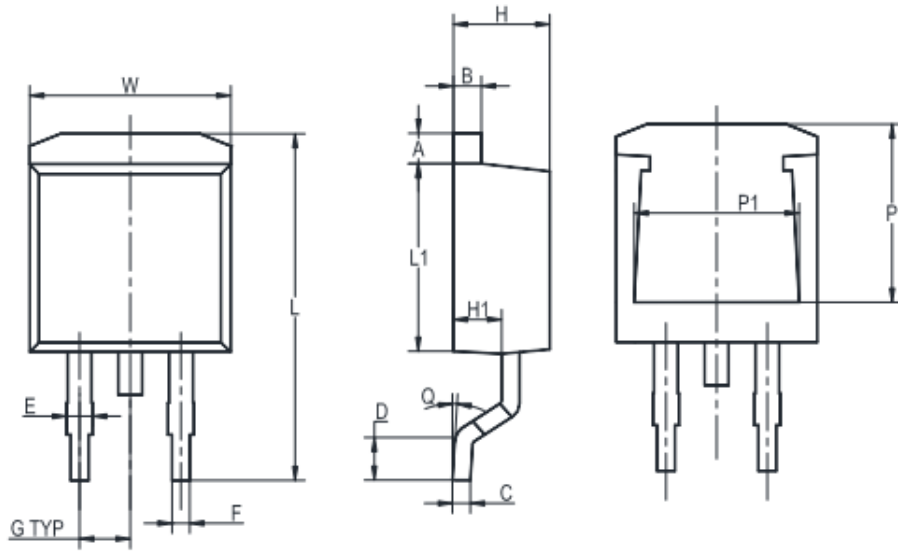

UNIT	A	B	C	D	E	F	G	W	H	H1	L	L1	Q	P	P1
mm	1.5	1.5	0.5	2.60	1.6	0.94	2.54	10.5	4.8	2.9	16.5	8.7	8°	7.6	8.2
	1.1	1.1	0.3	2.15	1.1	0.68	TYP	9.6	4.4	2.5	14.5	8.2	MAX	7.1	7.4

Figure4: Outline PG-TO263(HC&LM)

Revision History

Revision	Date	Subjects (major changes since last revision)
1.0	2022-08-03	Preliminary version
1.1	2022-09-14	Updated Vth limit
1.2	2022-11-16	Added package TO220
1.3	2023-02-06	Updated diagram2 transfer characteristics
1.4	2023-06-06	Added TO220F&263 package

X-ON Electronics

Largest Supplier of Electrical and Electronic Components

Click to view similar products for [MOSFET](#) category:

Click to view products by [ANHI](#) manufacturer:

Other Similar products are found below :

[IRFD120](#) [IRFY240C](#) [JANTX2N5237](#) [2SK2267\(Q\)](#) [BUK455-60A/B](#) [MIC4420CM-TR](#) [VN1206L](#) [NDP4060](#) [SI4482DY](#)
[IPS70R2K0CEAKMA1](#) [SQD23N06-31L-GE3](#) [TK16J60W,S1VQ\(O](#) [2SK2614\(TE16L1,Q\)](#) [DMN1017UCP3-7](#) [EFC2J004NUZTDG](#)
[DMN1053UCP4-7](#) [SQJ469EP-T1-GE3](#) [NTE2384](#) [DMC2700UDMQ-7](#) [DMN2080UCB4-7](#) [DMN61D9UWQ-13](#) [US6M2GTR](#)
[DMN31D5UDJ-7](#) [DMP22D4UFO-7B](#) [DMN1006UCA6-7](#) [DMN16M9UCA6-7](#) [STF5N65M6](#) [IRF40H233XTMA1](#) [STU5N65M6](#)
[DMN6022SSD-13](#) [DMN13M9UCA6-7](#) [DMTH10H4M6SPS-13](#) [DMN2990UFB-7B](#) [IPB80P04P405ATMA2](#) [2N7002W-G](#) [MCAC30N06Y-](#)
[TP](#) [MCQ7328-TP](#) [NTMC083NP10M5L](#) [NVMFS2D3P04M8LT1G](#) [BXP7N65D](#) [BXP4N65F](#) [AOL1454G](#) [WMJ80N60C4](#) [BXP2N20L](#)
[BXP2N65D](#) [BXT1150N10J](#) [BXT1700P06M](#) [TSM60NB380CP](#) [ROG](#) [RQ7L055BGTCR](#) [DMNH15H110SK3-13](#)