

MOSFET Silicon N-Channel MOS



1. Applications

Synchronous Rectification, Power Management, Load Switch

2. Features

Proprietary New Trench Technology
Fast Recovery Body Diode
Low Gate Charge Minimize Switching Loss

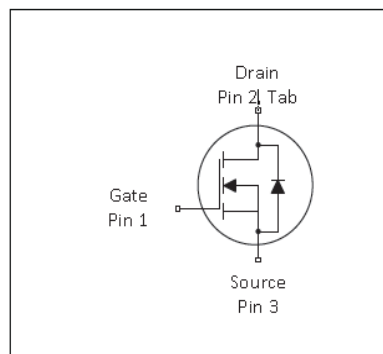

Table 1 Key Performance Parameters

Parameter	Value	Unit
$V_{DS} @ T_{j,max}$	100	V
$R_{DS(on),max}$	6.5	mΩ
$Q_{g,typ}$	67	nC
$I_{D,pulse}$	304	A

3. Packaging and Internal Circuit

Part Name	Package	Marking
AUN065N10	DFN5X6	AUN065N10
AUP065N10	TO220	AUP065N10



1 Maximum ratings

at $T_j = 25^\circ\text{C}$, unless otherwise specified

Table 2 Maximum ratings

Parameter	Symbol	Values			Unit	Note / Test Condition
		Min.	Typ.	Max.		
Continuous drain current ¹⁾	I_D		-	76	A	$T_C = 25^\circ\text{C}$
Pulsed drain current ²⁾	$I_{D,pulse}$	-		304	A	$T_C = 25^\circ\text{C}$
Avalanche energy, single pulse	E_{AS}	-	-	84	mJ	
Gate source voltage (static)	V_{GS}	-20	-	20	V	static;
Power dissipation(DFN5X6)	P_{tot}	-	-	91	W	$T_C = 25^\circ\text{C}$
Power dissipation(TO220)	P_{tot}	-	-	160	W	$T_C = 25^\circ\text{C}$
Storage temperature	T_{stg}	-55	-	150	$^\circ\text{C}$	
Operating junction temperature	T_j	-55	-	150	$^\circ\text{C}$	
Soldering Temperature Distance of 1.6mm from case for 10s	T_L			260	$^\circ\text{C}$	

¹⁾Limited by $T_{j,max}$. Maximum Duty Cycle $D = 0.50$

²⁾Pulse width t_p limited by $T_{j,max}$

³⁾Identical low side and high side switch with identical R_G

2 Thermal characteristics

Table 3 Thermal characteristics(TO220)

Parameter	Symbol	Values			Unit	Note / Test Condition
		Min.	Typ.	Max.		
Thermal resistance, junction - case	R_{thJC}	-	-	0.8	°C/W	-
Thermal resistance, junction - ambient	R_{thJA}	-	-	62	°C/W	device on PCB, minimal footprint

Table 3 Thermal characteristics(DFN5X6)

Parameter	Symbol	Values			Unit	Note / Test Condition
		Min.	Typ.	Max.		
Thermal resistance, junction - case	R_{thJC}	-	-	1.4	°C/W	-
Thermal resistance, junction - ambient	R_{thJA}	-	-	63	°C/W	device on PCB, minimal footprint

3 Electrical characteristics

at $T_j=25^\circ\text{C}$, unless otherwise specified

Table 4 Static characteristics

Parameter	Symbol	Values			Unit	Note / Test Condition
		Min.	Typ.	Max.		
Drain-source breakdown voltage	$V_{(BR)DSS}$	100	-	-	V	$V_{GS}=0V, I_D=250\mu A$
Gate threshold voltage	$V_{(GS)th}$	1		3	V	$V_{DS}=V_{GS}, I_D=250\mu A$
Zero gate voltage drain current	I_{DSS}	-	-	1	μA	$V_{DS}=100V, V_{GS}=0V, T_j=25^\circ\text{C}$
Gate-source leakage current	I_{GSS}	-	-	100	nA	$V_{GS}=20V, V_{DS}=0V$
Drain-source on-state resistance	$R_{DS(on)}$	-	5.8	6.5	m Ω	$V_{GS}=10V, I_D=20A, T_j=25^\circ\text{C}$
			7.9	11	m Ω	$V_{GS}=4.5V, I_D=20A, T_j=25^\circ\text{C}$

Table 5 Dynamic characteristics

Parameter	Symbol	Values			Unit	Note / Test Condition
		Min.	Typ.	Max.		
Input capacitance	C_{iss}	-	3729	-	pF	$V_{DS}=30V, V_{GS}=0V$ $f=1\text{MHz}$
Output capacitance	C_{oss}	-	1130	-	pF	$V_{DS}=30V, V_{GS}=0V$ $f=1\text{MHz}$
Reverse transfer capacitance	C_{rss}	-	64	-	pF	$V_{DS}=30V, V_{GS}=0V$ $f=1\text{MHz}$
Turn-on delay time	$t_{d(on)}$	-	25	-	ns	$V_{DD}=50V, V_{GS}=10V, R_G=6\Omega$ $I_D=20A$
Rise time	t_r	-	47	-	ns	$V_{DD}=50V, V_{GS}=10V, R_G=6\Omega$ $I_D=20A$
Turn-off delay time	$t_{d(off)}$	-	64	-	ns	$V_{DD}=50V, V_{GS}=10V, R_G=6\Omega$ $I_D=20A$
Fall time	t_f	-	23	-	ns	$V_{DD}=50V, V_{GS}=10V, R_G=6\Omega$ $I_D=20A$

Table 6 Gate charge characteristics

Parameter	Symbol	Values			Unit	Note / Test Condition
		Min.	Typ.	Max.		
Gate to source charge	Q_{gs}		13	-	nC	$V_{DS}=50V, V_{GS}=0$ to 10V $I_D=20A$
Gate to drain charge	Q_{gd}	-	14	-	nC	$V_{DS}=50V, V_{GS}=0$ to 10V $I_D=20A$
Gate charge total	Q_g	-	67	-	nC	$V_{DS}=50V, V_{GS}=0$ to 10V $I_D=20A$

Table 7 Reverse diode characteristics

Parameter	Symbol	Values			Unit	Note / Test Condition
		Min.	Typ.	Max.		
Diode forward voltage	V_{SD}	-		1.0	V	$V_{GS}=0V, I_F=1A, T_J=25^{\circ}C$

4 Electrical characteristics diagram

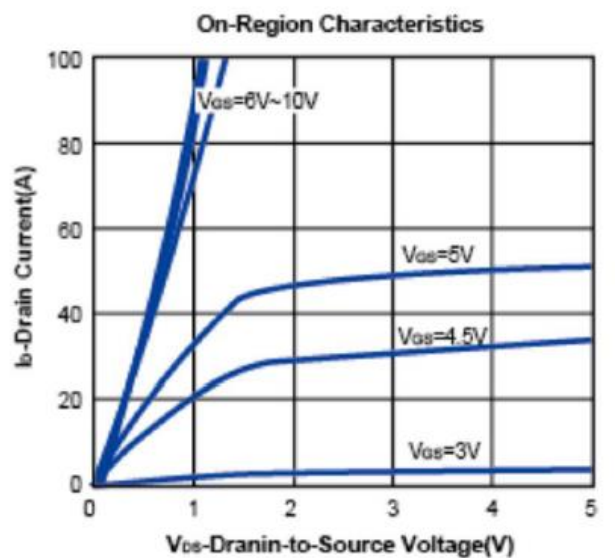
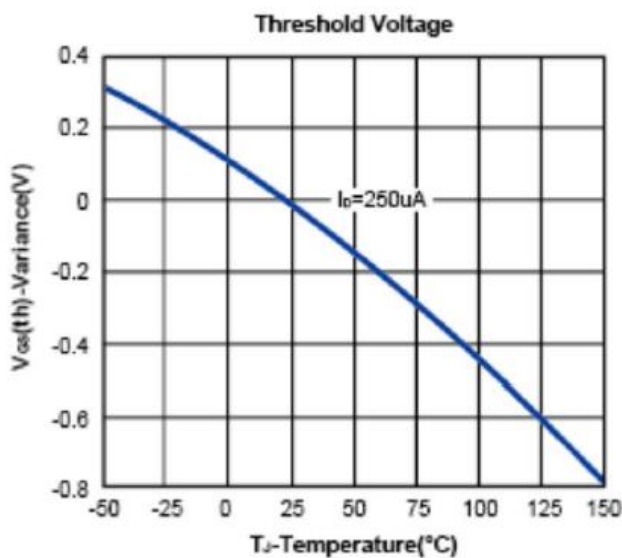
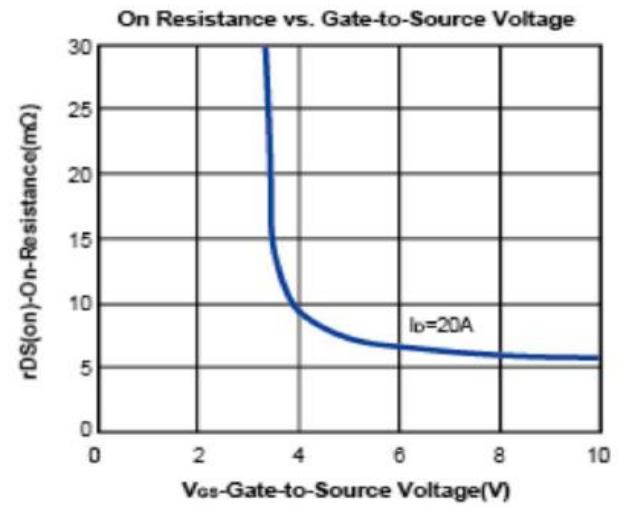
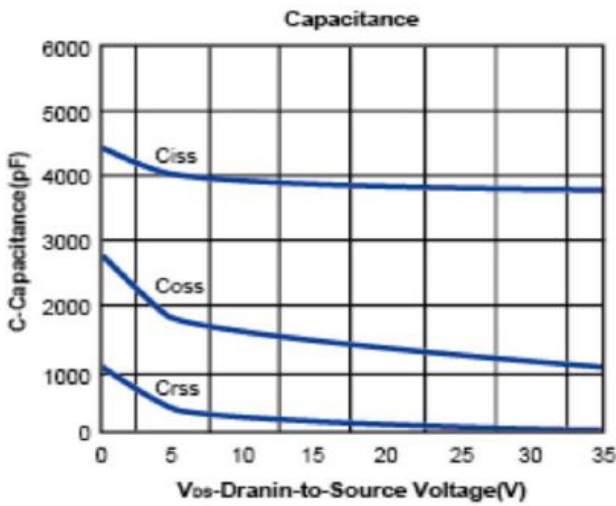
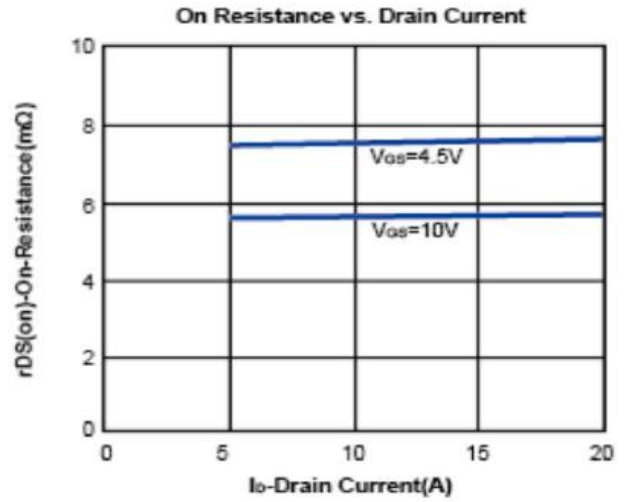
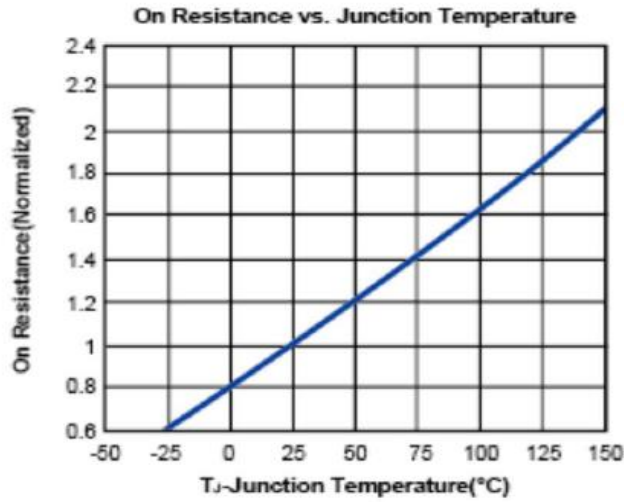

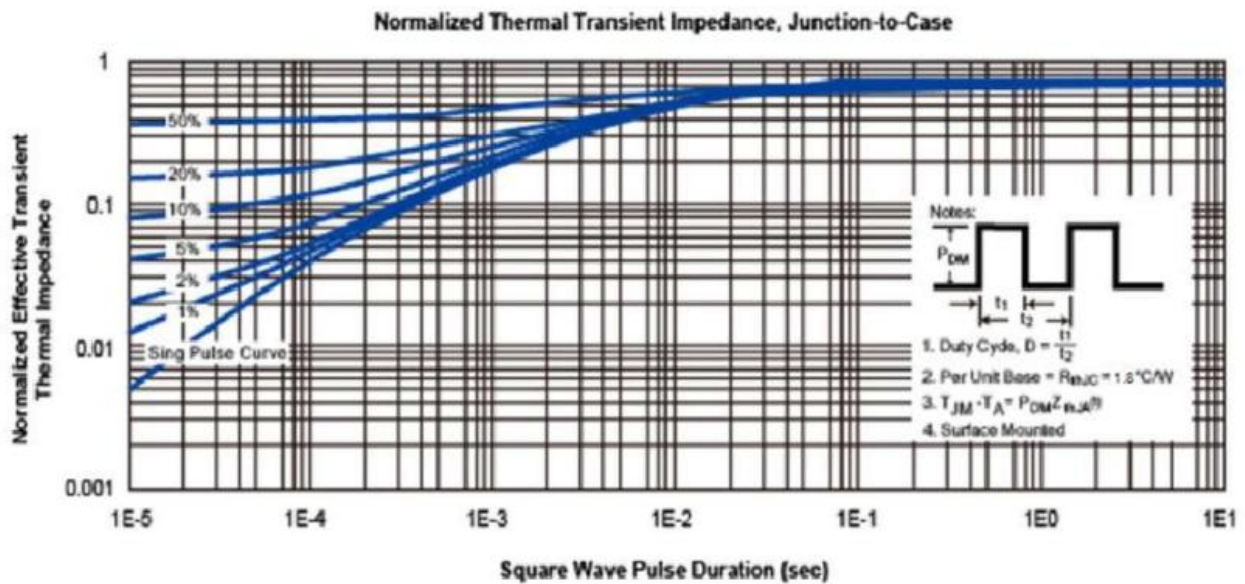
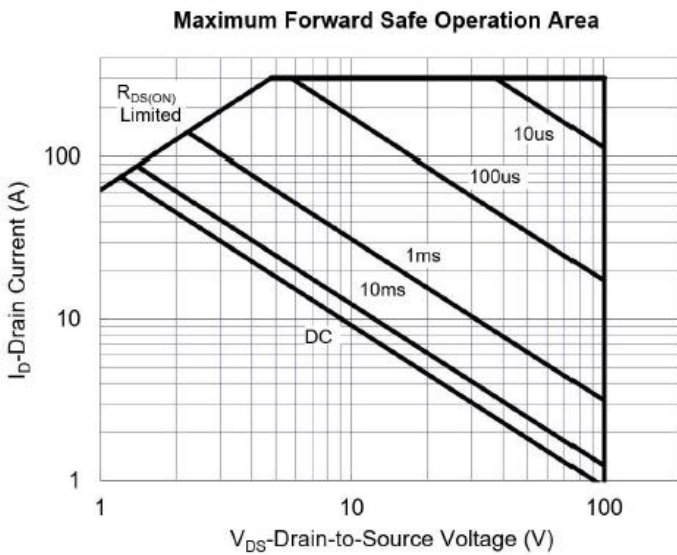
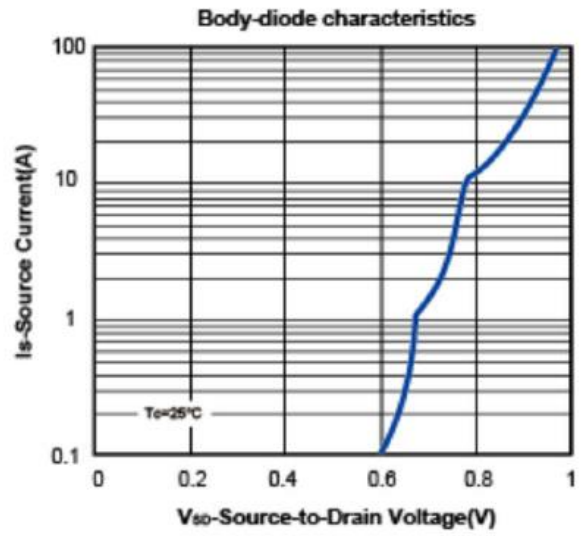
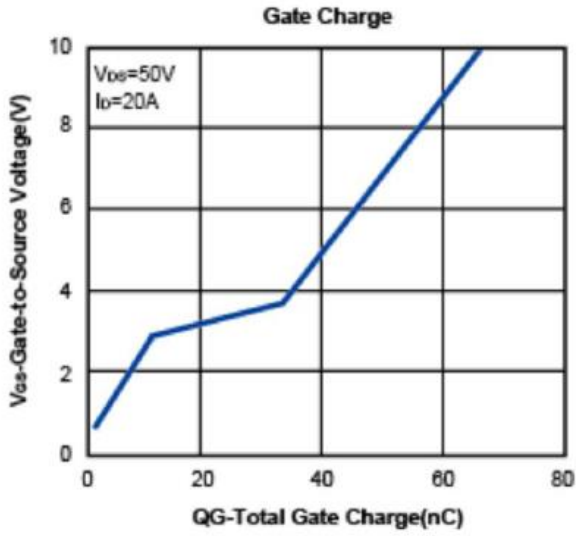

5 Package Outlines

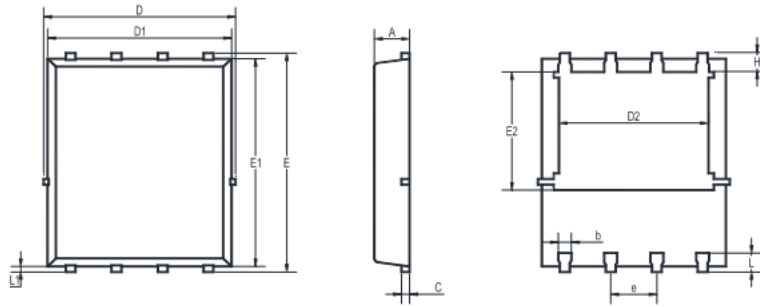

UNIT	A	b	C	D	D1	D2	E	E1	E2	e	L	L1	H
mm	1.12	0.51	0.34	5.26	5.1	4.5	6.25	6	3.66	1.37	0.71	0.2	0.71
	0.9	0.33	0.11	4.7	4.7	3.56	5.75	5.6	3.18	1.17	0.35	0.06	0.35

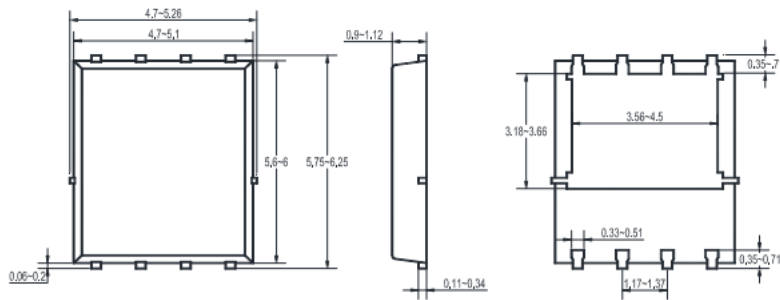

Figure 1: Outline PG-DFN5x6(HC)

Revision History

Revision	Date	Subjects (major changes since last revision)
1.0	2021-01-25	Preliminary version
1.1	2022-09-13	Updated Vth limit
1.2	2023-05-23	Added TO220 package

X-ON Electronics

Largest Supplier of Electrical and Electronic Components

Click to view similar products for [MOSFET](#) category:

Click to view products by [ANHI](#) manufacturer:

Other Similar products are found below :

[IRFD120](#) [IRFY240C](#) [JANTX2N5237](#) [2SK2267\(Q\)](#) [BUK455-60A/B](#) [MIC4420CM-TR](#) [VN1206L](#) [NDP4060](#) [SI4482DY](#)
[IPS70R2K0CEAKMA1](#) [SQD23N06-31L-GE3](#) [TK16J60W,S1VQ\(O](#) [2SK2614\(TE16L1,Q\)](#) [DMN1017UCP3-7](#) [EFC2J004NUZTDG](#)
[DMN1053UCP4-7](#) [SQJ469EP-T1-GE3](#) [NTE2384](#) [DMC2700UDMQ-7](#) [DMN2080UCB4-7](#) [DMN61D9UWQ-13](#) [US6M2GTR](#)
[DMN31D5UDJ-7](#) [DMP22D4UFO-7B](#) [DMN1006UCA6-7](#) [DMN16M9UCA6-7](#) [STF5N65M6](#) [IRF40H233XTMA1](#) [STU5N65M6](#)
[DMN6022SSD-13](#) [DMN13M9UCA6-7](#) [DMTH10H4M6SPS-13](#) [DMN2990UFB-7B](#) [IPB80P04P405ATMA2](#) [2N7002W-G](#) [MCAC30N06Y-](#)
[TP](#) [MCQ7328-TP](#) [NTMC083NP10M5L](#) [NVMFS2D3P04M8LT1G](#) [BXP7N65D](#) [BXP4N65F](#) [AOL1454G](#) [WMJ80N60C4](#) [BXP2N20L](#)
[BXP2N65D](#) [BXT1150N10J](#) [BXT1700P06M](#) [TSM60NB380CP](#) [ROG](#) [RQ7L055BGTCR](#) [DMNH15H110SK3-13](#)