

Low Dropout Linear Regulator Controller

Features

- **Wide Supply Voltage Range from 4.5 to 13.5V**
- **High Output Accuracy Over Operating Temperature and Loading Ranges**
- **Fast Transient Response**
- **Power-On-Reset Monitoring on VCC**
- **Programmable Soft-Start**
- **Low Shutdown Current**
- **Enable Control Function**
- **Under-Voltage Protection**
- **Two Versions of IC Available:**
 - APL5611: UVP Activated after V_{OUT} is Ready
 - APL5611A: UVP Activated after V_{CC} is Supplied
- **SOT-23-6 Package**
- **Lead Free and Green Devices Available (RoHS Compliant)**

General Description

The APL5611/A is a low dropout linear regulator controller. The APL5611/A could drive an external N-Channel MOSFET and provide an adjustable output by using an external resistive divider.

The APL5611/A integrates various functions. For example, a Power-On-Reset (POR) circuit monitors VCC supply voltage to prevent wrong operations; the function of Under-Voltage Protection (UVP) protects the device from short circuit condition. The soft-start of output voltage is adjustable by the external capacitor on SS pin. Moreover, the APL5611/A can be enabled by other power system; namely, holding the EN above 1.6V enables output and pulling the EN under 0.4V disables output.

The APL5611/A is available in a SOT-23-6 package.

Applications

- **Notebook PC Applications**
- **Motherboard Applications**

Pin Configuration

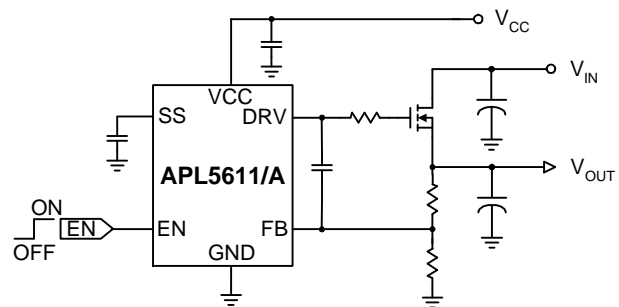
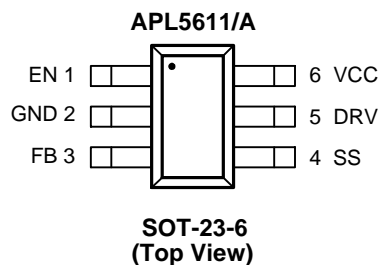

ANPEC reserves the right to make changes to improve reliability or manufacturability without notice, and advise customers to obtain the latest version of relevant information to verify before placing orders.

Ordering and Marking Information

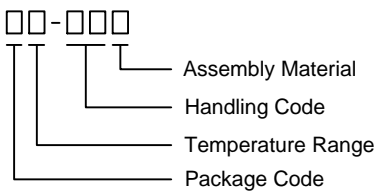
APL5611 APL5611A		Package Code C : SOT-23-6 Operating Ambient Temperature Range I : -40 to 85 °C Handling Code TR : Tape & Reel Assembly Material G : Halogen and Lead Free Device
APL5611 C:	<input type="text" value="L11X"/>	X - Date Code
APL5611A C:	<input type="text" value="LA1X"/>	X - Date Code

Note: ANPEC lead-free products contain molding compounds/die attach materials and 100% matte tin plate termination finish; which are fully compliant with RoHS. ANPEC lead-free products meet or exceed the lead-free requirements of IPC/JEDEC J-STD-020D for MSL classification at lead-free peak reflow temperature. ANPEC defines “Green” to mean lead-free (RoHS compliant) and halogen free (Br or Cl does not exceed 900ppm by weight in homogeneous material and total of Br and Cl does not exceed 1500ppm by weight).

Absolute Maximum Ratings (Note 1)

Symbol	Parameter	Rating	Unit
V_{CC}	VCC Input Voltage (VCC to GND)	-0.3 to 15	V
	EN, SS, to GND Voltage	-0.3 to 7	V
V_{FB}	FB to GND Voltage	-0.3 to 7	V
V_{DRV}	DRV to GND Voltage	-0.3 to $V_{CC}+0.3$	V
T_J	Maximum Junction Temperature	150	°C
T_{STG}	Storage Temperature	-65 to 150	°C
T_{SDR}	Maximum Lead Soldering Temperature, 10 Seconds	260	°C

Note 1: Absolute Maximum Ratings are those values beyond which the life of a device may be impaired. Exposure to absolute maximum rating conditions for extended periods may affect device reliability.

Thermal Characteristic

Symbol	Parameter	Typical Value	Unit
θ_{JA}	Junction-to-Ambient Resistance in Free Air ^(Note 2) SOT-23-6	250	°C/W

Note 2: θ_{JA} is measured with the component mounted on a high effective thermal conductivity test board in free air.

Recommended Operating Conditions (Note 3)

Symbol	Parameter	Range	Unit
V_{CC}	VCC Input Voltage (VCC to GND)	4.5 to 13.5	V
V_{EN}	EN to GND Voltage	0 to 5.5	V
V_{OUT}	VOU Output Voltage ^(Note4)	$0.8 \sim V_{IN} - V_{DROP}$	V
T_A	Ambient Temperature	-40 to 85	°C
T_J	Junction Temperature	-40 to 125	°C

Note 3: Refer to the typical application circuit.

Note 4: V_{DROP} defined as the $V_{IN}-V_{OUT}$ voltage at $V_{OUT} = 98\%$ normal V_{OUT} . The linear regulator must provide the output MOSFET with sufficient Gate-to-Source voltage ($V_{GS} = V_{CC} - V_{OUT}$) to regulate the output voltage.

Electrical Characteristics

Unless otherwise specified, these specifications apply over $V_{CC} = 5/12V$, $T_A = -40$ to $85\text{ }^\circ\text{C}$. Typical values are at $T_A = 25^\circ\text{C}$.

Symbol	Parameter	Test Conditions	APL5611/A			Unit
			Min.	Typ.	Max.	
SUPPLY CURRENT						
I_{CC}	VCC Supply Current	$V_{CC} = 12V$	-	0.8	1.0	mA
		$V_{CC} = 5V$	-	0.8	1.0	
I_{SD}	VCC Shutdown Current	$V_{CC} = 12V, EN=GND$	-	-	5	μA
		$V_{CC} = 5V, EN=GND$	-	-	5	
POWER-ON-RESET (POR)						
	VCC POR Threshold	V_{CC} rising	3.8	4.0	4.2	V
	VCC POR Hysteresis		-	0.4	-	V
REFERENCE VOLTAGE						
V_{REF}	Reference Voltage	$V_{CC} = 12V, T_A = 25\text{ }^\circ\text{C}$	-	0.8	-	V
	Reference Voltage Accuracy	$V_{CC} = 12V$	-1	-	1	%
	Line Regulation	$V_{CC} = 4.5V$ to $13.2V$	-1.5	-	1.5	%
	FB Input Current		-100	-	100	nA
ERROR AMPLIFIER						
	Unity Gain Bandwidth	$V_{CC} = 5/12V$	-	2	-	MHz
	Open Loop DC Gain	$V_{CC} = 12V$, No Load	60	80	-	dB
PSRR	Power Supply Rejection Ratio	$V_{CC} = 12V$, 100Hz, No Load	50	-	-	dB
$V_{DRV (high)}$	DRV High Voltage	$V_{CC} = 12V, I_{DRV (SOURCE)} = 5mA, V_{FB} = 0.6V$	11.2	11.5	-	V
		$V_{CC} = 5V, I_{DRV (SOURCE)} = 5mA, V_{FB} = 0.6V$	-	4.7	-	
$V_{DRV (low)}$	DRV Low Voltage	$V_{CC} = 12V, I_{DRV (SINK)} = 5mA, V_{FB} = 1V$	-	0.5	1	V
		$V_{CC} = 5V, I_{DRV (SINK)} = 5mA, V_{FB} = 1V$	-	0.8	-	
$I_{DRV (source)}$	DRV Source Current	$V_{CC} = 12V, V_{DRV} = 6V, V_{FB} = 0.6V$	-	50	-	mA
		$V_{CC} = 5V, V_{DRV} = 2.5V, V_{FB} = 0.6V$	-	10	-	
$I_{DRV (sink)}$	DRV Sink Current	$V_{CC} = 12V, V_{DRV} = 6V, V_{FB} = 1V$	-	40	-	mA
		$V_{CC} = 5V, V_{DRV} = 2.5V, V_{FB} = 1V$	-	10	-	
ENABLE						
$V_{EN (TH)}$	EN Logic High Threshold Voltage	V_{EN} rising, $T_A = 25^\circ\text{C}$	0.55	0.8	1.05	V
	EN Hysteresis		-	50	-	mV
	EN Shutdown Debounce	V_{EN} falling	-	2	-	μs
	EN Internal Pull High Current		-	5	-	μA
SOFT-START						
I_{SS}	SS Current		3	4.5	6	μA
UNDER-VOLTAGE PROTECTION (UVP)						
$V_{UV (TH)}$	Under-Voltage Threshold	$V_{EN} = 5V, V_{FB}$ falling	68	75	82	%
	UVP Debounce Interval		-	5	-	μs

Typical Operating Characteristics

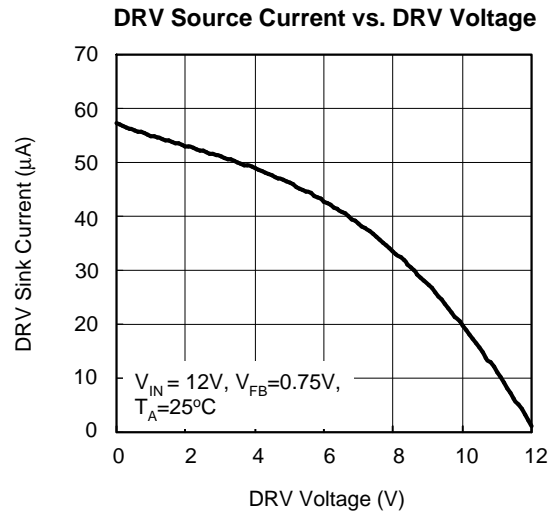
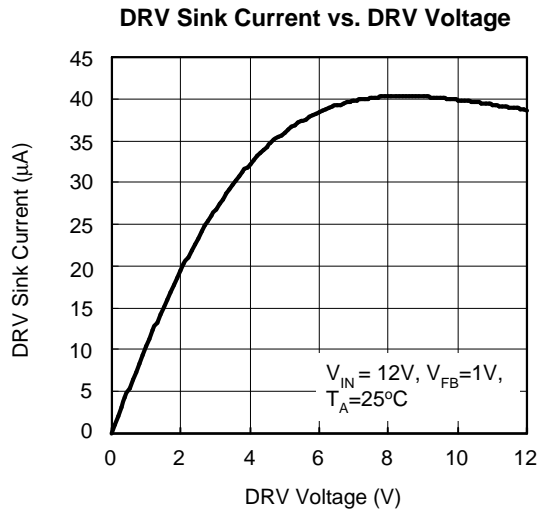
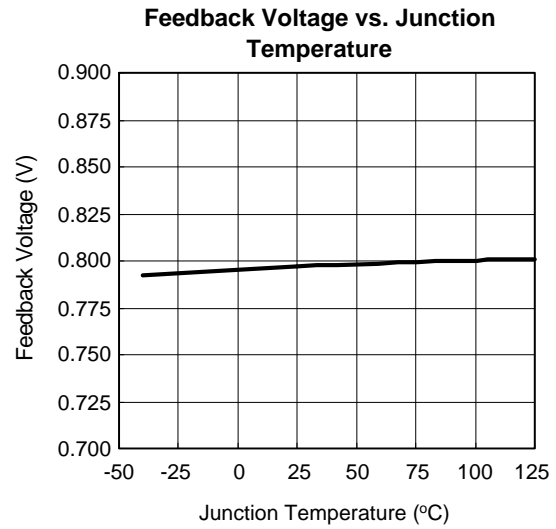
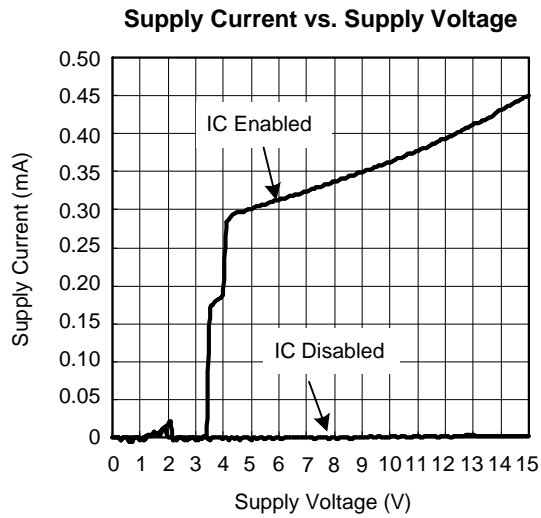

Operating Waveforms

The test condition $T_A = 25^\circ\text{C}$ unless otherwise specified.

Turn On Response

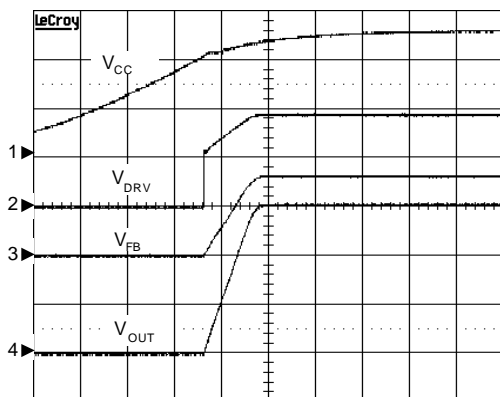

$V_{CC}=5\text{V}$, $V_{IN}=5\text{V}$, $V_{OUT}=1.5\text{V}$, $C_{IN}=33\mu\text{F}/$
 Electrolytic, $C_{OUT}=120\mu\text{F}/$ Electrolytic,
 $C_{SS}=0.01\mu\text{F}$
 CH1: V_{CC} , 2V/Div, DC
 CH2: V_{DRV} , 2V/Div, DC
 CH3: V_{FB} , 0.5V/Div, DC
 CH4: V_{OUT} , 0.5V/Div, DC
 TIME: 2ms/Div

Turn Off Response

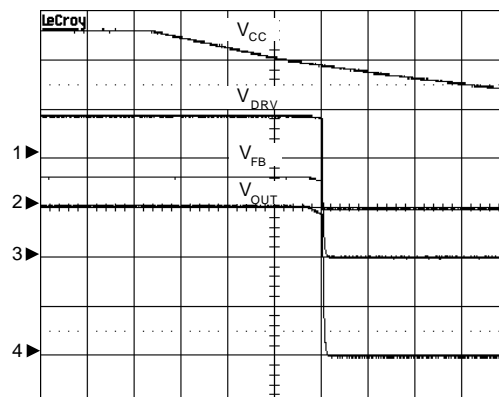

$V_{CC}=5\text{V}$, $V_{IN}=5\text{V}$, $V_{OUT}=1.5\text{V}$, $C_{IN}=33\mu\text{F}/$
 Electrolytic, $C_{OUT}=120\mu\text{F}/$ Electrolytic,
 $C_{SS}=0.01\mu\text{F}$
 CH1: V_{CC} , 2V/Div, DC
 CH2: V_{DRV} , 2V/Div, DC
 CH3: V_{FB} , 0.5V/Div, DC
 CH4: V_{OUT} , 0.5V/Div, DC
 TIME: 50ms/Div

Load Transient Response-1

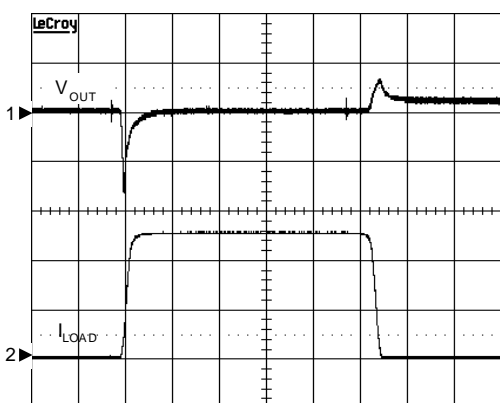

$V_{CC}=5\text{V}$, $V_{IN}=5\text{V}$, $V_{OUT}=1.2\text{V}$,
 $I_{LOAD}=0-5-0\text{A}$ (rising/falling edge=1A/ μs),
 $C_{IN}=22\mu\text{F}/$ MLCC, $C_{OUT}=100\mu\text{F}/$ Electrolytic,
 CH1: V_{OUT} , 50mV/Div, AC
 CH2: I_{LOAD} , 2A/Div, DC
 TIME: 20 $\mu\text{s}/$ Div

Load Transient Response-2

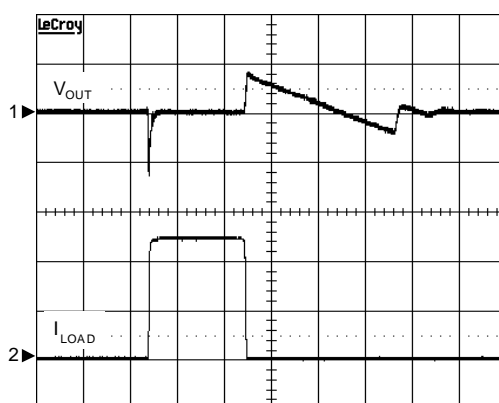

$V_{CC}=5\text{V}$, $V_{IN}=5\text{V}$, $V_{OUT}=1.5\text{V}$,
 $I_{LOAD}=0-5-0\text{A}$ (rising/falling edge=1A/ μs),
 $C_{IN}=22\mu\text{F}/$ MLCC, $C_{OUT}=22\mu\text{F}/$ MLCC,
 CH1: V_{OUT} , 50mV/Div, AC
 CH2: I_{LOAD} , 2A/Div, DC
 TIME: 100 $\mu\text{s}/$ Div

Operating Waveforms (Cont.)

The test condition $T_A = 25^\circ\text{C}$ unless otherwise specified.

Load Transient Response-3

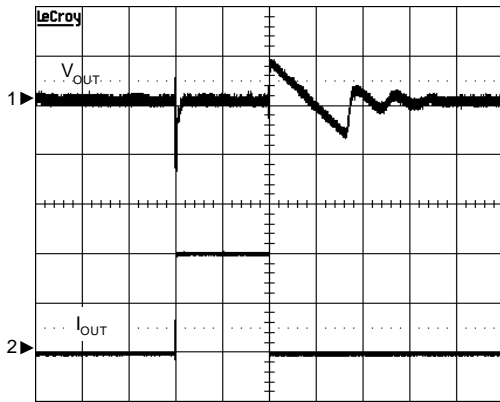

$V_{CC} = 5\text{V}$, $V_{IN} = 5\text{V}$, $V_{OUT} = 1.5\text{V}$,
 $I_{LOAD} = 0-0.2-0\text{A}$ (rising/falling edge = $1\text{A}/\mu\text{s}$),
 $C_{IN} = 22\mu\text{F}/\text{MLCC}$, $C_{OUT} = 22\mu\text{F}/\text{MLCC}$,
 CH1: V_{OUT} , 20mV/Div, AC
 CH2: I_{OUT} , 100mA/Div, DC
 TIME: 100µs/Div

Short Circuit Response

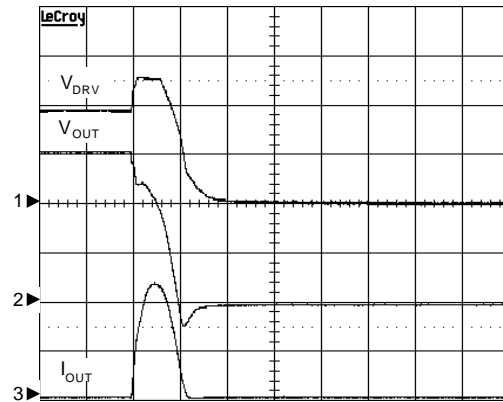

$V_{CC} = 5\text{V}$, $V_{IN} = 5\text{V}$, $V_{OUT} = 1.5\text{V}$,
 $C_{IN} = 22\mu\text{F}/\text{MLCC}$, $C_{OUT} = 22\mu\text{F}/\text{MLCC}$,
 CH1: V_{DRV} , 2V/Div, DC
 CH2: V_{OUT} , 0.5V/Div, DC
 CH3: I_{OUT} , 20A/Div, DC
 TIME: 50µs/Div

Pin Description

PIN		FUNCTION
NO.	NAME	
1	EN	Enable control pin. Pulling the EN high enables the V_{OUT} ; forcing the EN low ($V_{EN} < 0.4V$) disables the V_{OUT} . When re-enabled, the IC undergoes a new soft-start process. The EN pin is pulled high internally, hence it can be left open if the EN control is not used.
2	GND	Ground pin of the circuitry. All voltage levels are measured with respect to this pin.
3	FB	Voltage Feedback Pin. Connecting this pin to an external resistor divider receives the feedback voltage of the regulator.
4	SS	Connect this pin to a capacitor for soft-start.
5	DRV	This pin drives the gate of an external N-channel MOSFET for linear regulator.
6	VCC	Power input pin of the device. The voltage at this pin is monitored for Power-On-Reset purpose.

Block Diagram

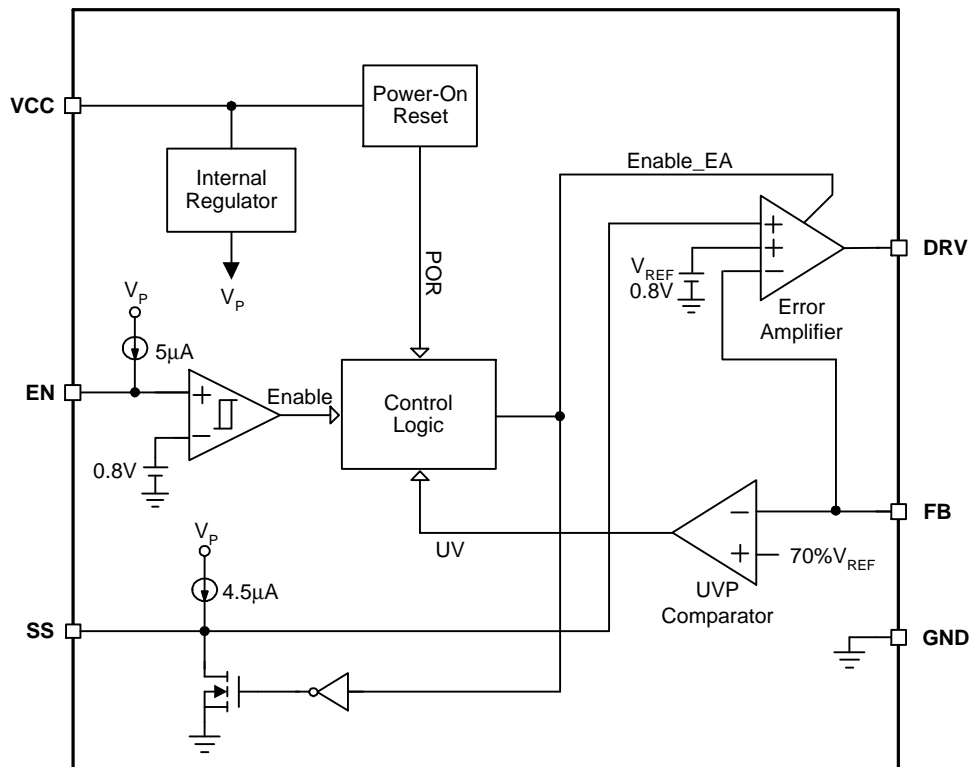

Typical Application Circuit

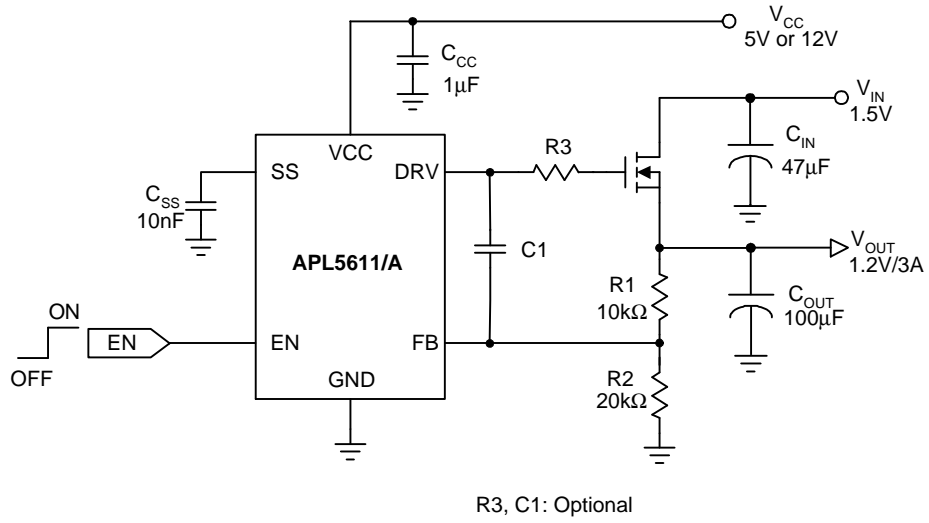

Function Description

Power-On-Reset (POR)

The APL5611/A monitors the VCC pin voltage (V_{CC}) for power-on-reset function to prevent wrong operation. The built-in POR circuit keeps the output shutting off until internal circuit is operating properly. Typical POR threshold is 4.0V with 0.4V hysteresis.

Soft-Start

The APL5611/A provides an adjustable soft-start circuitry to control rise rate of the output voltage and limit the current surge during start-up. The soft-start time is set with a capacitor from the SS pin to the ground. The capacitor is charged to VP with a constant 4.5 μ A (typ.) current source.

Under-Voltage Protection (UVP)

The APL5611/A monitors the voltage on FB. When the voltage on FB falls below the under-voltage threshold, the UVP circuit shuts off the output voltage immediately by pulling down DRV to 0V and latches APL5611/A off, requiring either a V_{CC} POR or EN re-enable again to restart. The UVP activation timing is different in these 2 variants of IC, APL5611 and APL5611A. The APL5611 UVP is activated after V_{OUT} voltage has reached 90% POK threshold while the APL5611A UVP is activated after V_{CC} has been applied to VCC pin. In order to avoid erroneous UVP latch-off in APL5611A, please make sure the power sequence is a proper one when you use the APL5611A. For the suggested power sequence of APL5611A, you can refer to the Power Sequencing in Application Information.

Enable Control

The APL5611/A has a dedicated enable pin (EN). A logic low signal applied to this pin shuts down the output. Following a shutdown, a logic high signal re-enables the output through initiation of a new soft-start cycle. It's not necessary to use an external transistor to save cost.

Power-OK and Delay

The APL5611/A indicates the status of the output voltage by monitoring the feedback voltage (V_{FB}) on FB pin. As the V_{FB} rises and reaches the rising Power-OK voltage threshold (V_{POKTH}), an internal delay function starts to work. At the end of the delay time, the IC turns off the internal NMOS of the POK to indicate that the output is ok. As the V_{FB} falls and reaches the falling Power-OK voltage threshold, the IC turns on the NMOS of the POK (after a debounce time of 5 μ s typical).

Output Voltage Regulation

The APL5611/A is a linear regulator controller. An external N-channel MOSFET should be connected to DRV as the pass element. The output voltage set by the resistor divider is determined by:

$$V_{OUT} = 0.8 \cdot \left(1 + \frac{R1}{R2} \right)$$

Where R1 is connected from VOUT to FB and R2 is connected from FB to GND.

Application Information

Input Capacitor

The APL5611/A requires proper input capacitor of V_{IN} (connected to the external MOSFET's drain) to supply surge current during stepping load transients to prevent the input rail from dropping. Because the parasitic inductor from the voltage sources or other bulk capacitors to the V_{IN} limits the slew rate of the surge current, it is necessary to place the input capacitor near the MOSFET's drain as close as possible. If the MOSFET is located near the bulk capacitor for upstream voltage regulator, this input capacitor may not be required. The input capacitor for V_{IN} should be larger than $1\mu\text{F}$. Higher capacitance of this V_{IN} input capacitor is needed if the stepping load transients are large and fast.

Another input capacitor for V_{CC} is recommended. Placing the input capacitor of V_{CC} as close to VCC pin as possible prevents outside noise from entering APL5611/A's control circuitry. The recommended capacitance of VCC input capacitor is $1\mu\text{F}$.

Output Capacitor

The APL5611/A needs a proper output capacitor to maintain circuit stability and to improve transient response over temperature and current. In order to insure the circuit stability, the proper output capacitor value should be larger than $10\mu\text{F}$. With X5R and X7R dielectrics, $22\mu\text{F}$ is sufficient at all operating temperatures.

Soft-Start Capacitor

The soft-start capacitor on SS pin can reduce the inrush current and overshoot of output voltage. The capacitor is charge to V_{CC} with a constant $4.5\mu\text{A}$ (typ.) current source, I_{SS} . This results in a linear charge of the soft-start capacitor and thus the output voltage. The soft-start period, t_{SS} , ends once the capacitor voltage reaches 0.8V (typ.). The soft-start capacitor is calculated using the equation:

$$C_{SS} = (I_{SS} \times t_{SS}) / 0.8$$

Where C_{SS} is the soft-start capacitor. I_{SS} is the soft-start current of SS pin. T_{SS} is the soft-start time you set for your application.

MOSFET Selection

APL5611/A requires an N-channel MOSFET as a pass element. There are some parameters must be considered in selecting a MOSFET, including: Threshold Voltage V_{TH} , $R_{DS(on)}$, Continuous I_{DS} current and Package Thermal Resistance. The MOSFET selection guidelines are listed as below:

1. Threshold Voltage V_{TH} : Select the MOSFET V_{TH} rating to meet the following equation:

$$V_{TH} < V_{CC(min)} - V_{OUT(max)}$$

2. $R_{DS(on)}$: Select the MOSFET $R_{DS(on)}$ to ensure that the output voltage will never enter dropout:

$$R_{DS(on)(max)} < (V_{IN(min)} - V_{OUT(max)}) / I_{OUT(max)}$$

(Note: $R_{DS(on)(max)}$ must be met at all temperatures and at the minimum V_{GS} condition)

3. Continuous $I_{DS(max)}$: Select the $I_{DS(max)}$ that can support the output current:

$$\text{Continuous } I_{DS(max)} > I_{OUT(max)}$$

4. Package Thermal Resistance $\theta_{(JA)}$: Select a package of MOSFET that can dissipate the heat, $\theta_{(JA)} < (T_J - T_A) / P_D$, where T_J is the maximum allowable Junction temperature of MOSFET, T_A is the ambient temperature, P_D is the maximum power dissipation on MOSFET, calculated as below:

$$P_D = (V_{IN(max)} - V_{OUT(min)}) \times I_{OUT(max)}$$

Power Sequencing (Only for APL5611A)

At start-up, it is necessary to ensure that the V_{IN} (the voltage supplied to MOSFET drain), V_{CC} and V_{EN} are sequenced correctly to avoid erroneous latch-off. To avoid UVP latch-off happened at start-up due to sequencing issues, the key method is the V_{IN} should be larger than the output under-voltage threshold plus the drop through the pass MOSFET when that output is enabled.

Figure 1 and 2 show the two types of power on sequence. Figure 1 shows the V_{CC} comes up before the V_{IN} , and then the output would be enabled when the V_{EN} is applied. Figure 2 shows the V_{IN} comes up before the V_{CC} , and then the output can either be enabled with the V_{CC} or V_{EN} . Recommended power on sequence is shown in Figure1 and 2.

Application Information (Cont.)

Power Sequencing (Only for APL5611A) (Cont.)

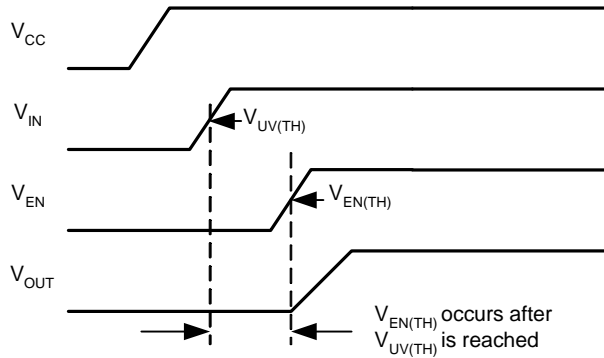

Figure 1. APL5611A supply comes up before MOSFET drain supply

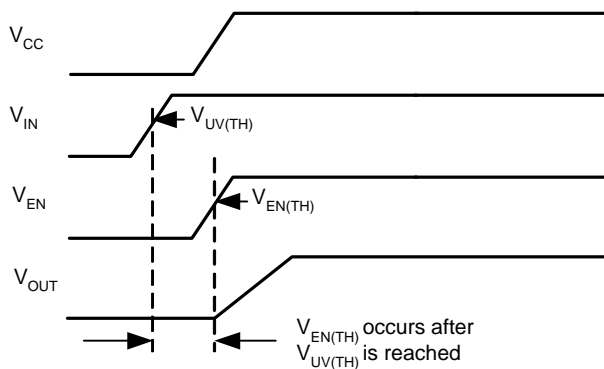

Figure 2. MOSFET drain supply comes up before APL5611A supply

Short Circuit Concerns (Only for APL5611)

Since the APL5611 UVP function is activated after the V_{OUT} reaches 90% level, any combinations of sequence among V_{IN} , V_{CC} , and V_{EN} are allowable. However, please note that the advantage of none-power-sequencing brings a drawback. If and only if a short circuit condition of output voltage occurs before V_{IN} supply, the UVP won't be activated. Thus, the short circuit current persists to flow and could impair the MOSFET. If in your application the short circuit is most likely to be encountered before V_{IN} supply, we suggest you use the APL5611A instead of the APL5611, who can provide this short circuit protection. Nevertheless, if the V_{IN} supply can provide the OCP protection, this short circuit won't be an issue in APL5611.

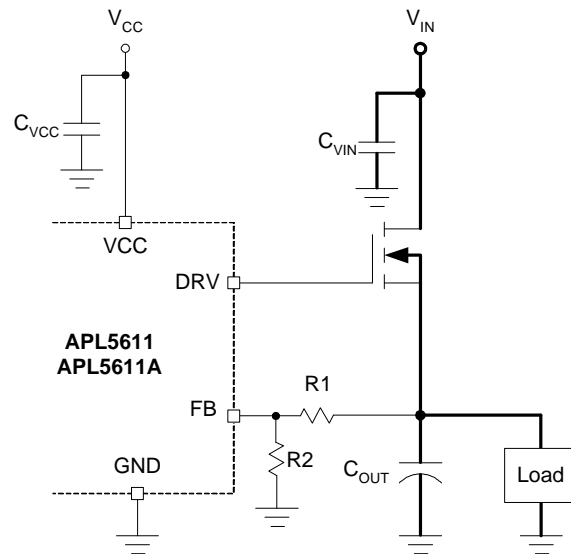

Figure 3

Layout Consideration

Figure 3 illustrates the layout. Below is a checklist for your layout:

1. Please place the input capacitor C_{VCC} close to the VCC pin.
2. Please place the C_{VIN} close to the MOSFET's drain.
3. Layout a copper plane for N-channel MOSFET's drain to improve the heat dissipation.
4. Output capacitor C_{OUT} for load must be placed near the load as close as possible.
5. Large current paths, the bold lines in figure 3, must have wide tracks.

Package Information

SOT-23-6

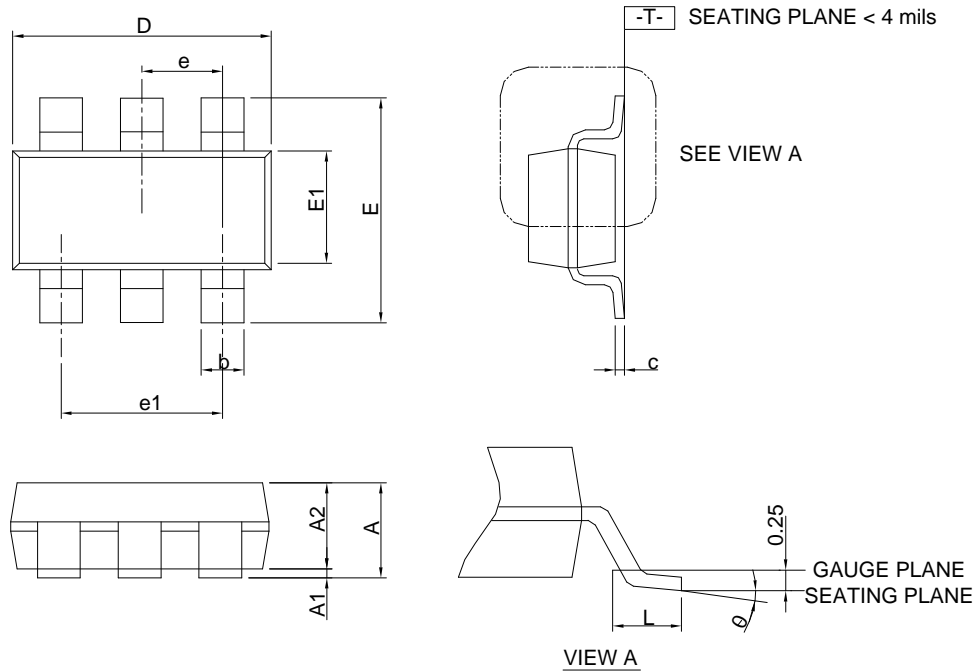

SYMBOL	SOT-23-6			
	MILLIMETERS		INCHES	
	MIN.	MAX.	MIN.	MAX.
A		1.45		0.057
A1	0.00	0.15	0.000	0.006
A2	0.90	1.30	0.035	0.051
b	0.30	0.50	0.012	0.020
c	0.08	0.22	0.003	0.009
D	2.70	3.10	0.106	0.122
E	2.60	3.00	0.102	0.118
E1	1.40	1.80	0.055	0.071
e	0.95 BSC		0.037 BSC	
e1	1.90 BSC		0.075 BSC	
L	0.30	0.60	0.012	0.024
θ	0°	8°	0°	8°

Note : 1. Follow JEDEC TO-178 AB.
 2. Dimension D and E1 do not include mold flash, protrusions or gate burrs. Mold flash, protrusion or gate burrs shall not exceed 10 mil per side.

Carrier Tape & Reel Dimensions

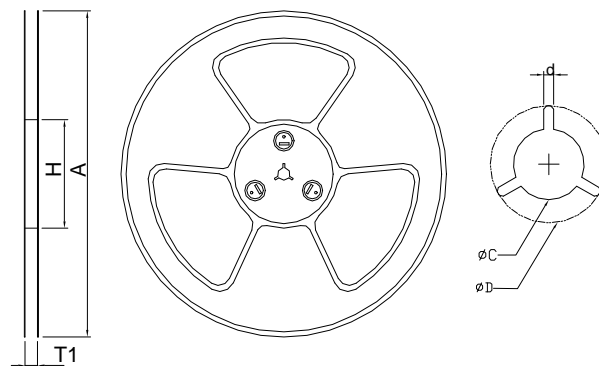
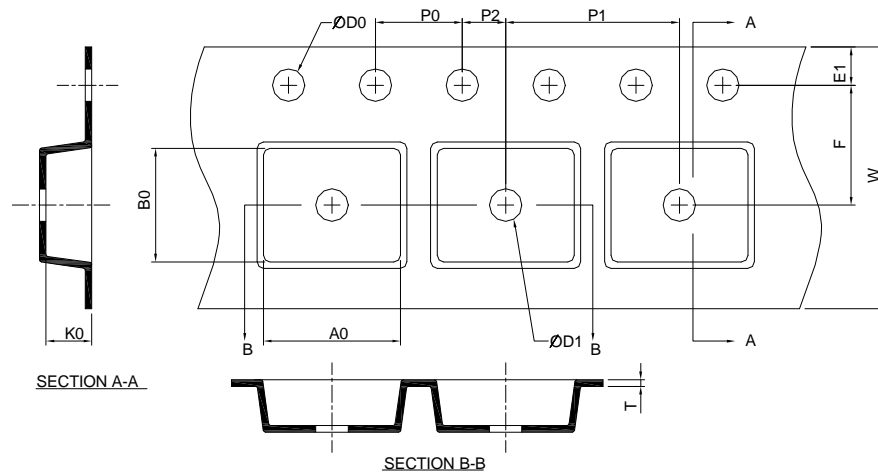

Application	A	H	T1	C	d	D	W	E1	F
SOT-23-6	178.0 ±0.00	50 MIN.	8.4+2.00 -0.00	13.0+0.50 -0.20	1.5 MIN.	20.2 MIN.	8.0 ±0.30	1.75 ±0.10	3.5 ±0.05
	P0	P1	P2	D0	D1	T	A0	B0	K0
	4.0 ±0.10	4.0 ±0.10	2.0 ±0.05	1.5+0.10 -0.00	1.0 MIN.	0.6+0.00 -0.40	3.20 ±0.20	3.10 ±0.20	1.50 ±0.20

(mm)

Devices Per Unit

Package Type	Unit	Quantity
SOT-23-6	Tape & Reel	3000

Taping Direction Information

SOT-23-6

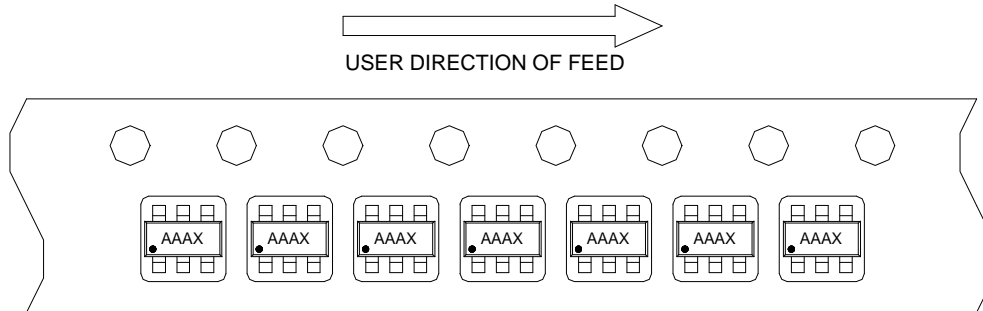

Classification Profile

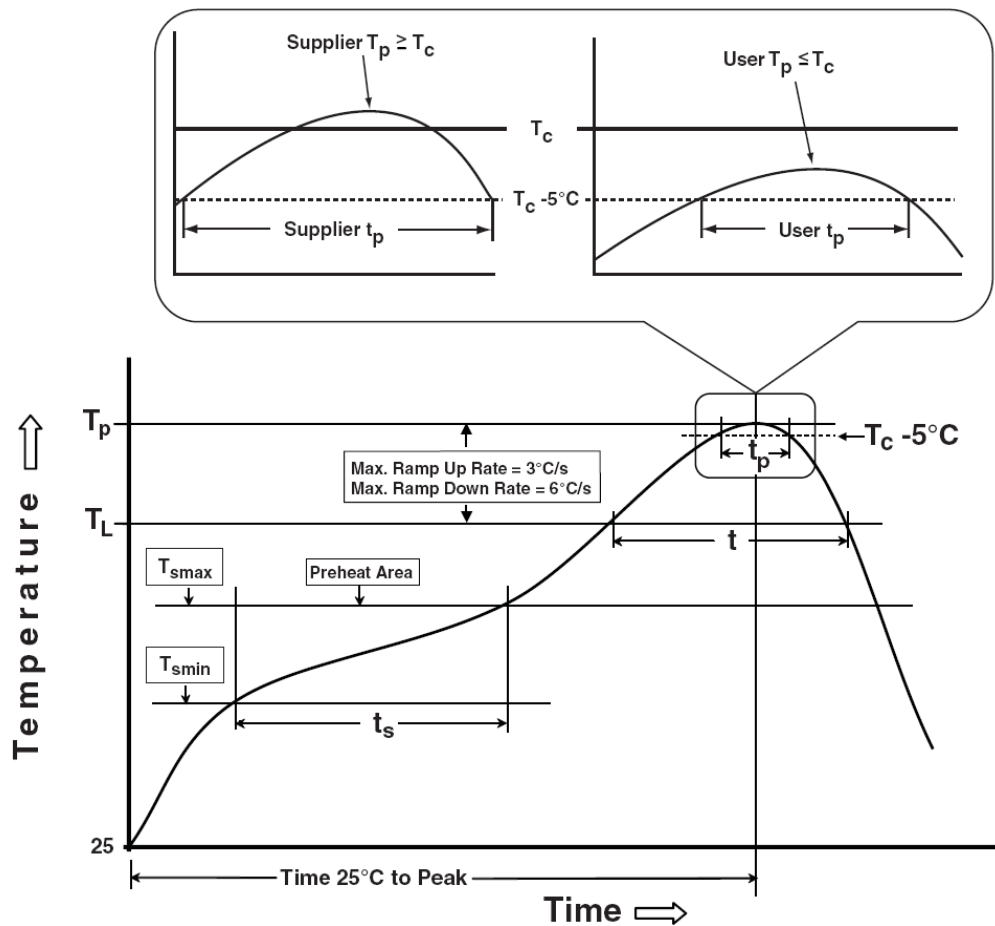

Classification Reflow Profiles

Profile Feature	Sn-Pb Eutectic Assembly	Pb-Free Assembly
Preheat & Soak		
Temperature min (T_{smin})	100 °C	150 °C
Temperature max (T_{smax})	150 °C	200 °C
Time (T_{smin} to T_{smax}) (t_s)	60-120 seconds	60-120 seconds
Average ramp-up rate (T_{smax} to T_p)	3 °C/second max.	3°C/second max.
Liquidous temperature (T_L)	183 °C	217 °C
Time at liquidous (t_L)	60-150 seconds	60-150 seconds
Peak package body Temperature (T_p)*	See Classification Temp in table 1	See Classification Temp in table 2
Time (t_p)** within 5°C of the specified classification temperature (T_c)	20** seconds	30** seconds
Average ramp-down rate (T_p to T_{smax})	6 °C/second max.	6 °C/second max.
Time 25°C to peak temperature	6 minutes max.	8 minutes max.
* Tolerance for peak profile Temperature (T_p) is defined as a supplier minimum and a user maximum.		
** Tolerance for time at peak profile temperature (t_p) is defined as a supplier minimum and a user maximum.		

Table 1. SnPb Eutectic Process – Classification Temperatures (T_c)

Package Thickness	Volume mm ³ <350	Volume mm ³ ≥350
<2.5 mm	235 °C	220 °C
≥2.5 mm	220 °C	220 °C

Table 2. Pb-free Process – Classification Temperatures (T_c)

Package Thickness	Volume mm ³ <350	Volume mm ³ 350-2000	Volume mm ³ >2000
<1.6 mm	260 °C	260 °C	260 °C
1.6 mm – 2.5 mm	260 °C	250 °C	245 °C
≥2.5 mm	250 °C	245 °C	245 °C

Reliability Test Program

Test item	Method	Description
SOLDERABILITY	JESD-22, B102	5 Sec, 245°C
HOLT	JESD-22, A108	1000 Hrs, Bias @ $T_j=125^\circ\text{C}$
PCT	JESD-22, A102	168 Hrs, 100%RH, 2atm, 121°C
TCT	JESD-22, A104	500 Cycles, -65°C~150°C
HBM	MIL-STD-883-3015.7	VHBM 2KV
MM	JESD-22, A115	VMM 200V
Latch-Up	JESD 78	10ms, 1 _{tr} 100mA

Customer Service

Anpec Electronics Corp.

Head Office :

No.6, Dusing 1st Road, SBIP,
Hsin-Chu, Taiwan, R.O.C.
Tel : 886-3-5642000
Fax : 886-3-5642050

Taipei Branch :

2F, No. 11, Lane 218, Sec 2 Jhongsing Rd.,
Sindian City, Taipei County 23146, Taiwan
Tel : 886-2-2910-3838
Fax : 886-2-2917-3838

X-ON Electronics

Largest Supplier of Electrical and Electronic Components

Click to view similar products for [LDO Voltage Regulators](#) category:

Click to view products by [Anpec](#) manufacturer:

Other Similar products are found below :

[AP7363-SP-13](#) [L79M05TL-E](#) [AP7362-HA-7](#) [PT7M8202B12TA5EX](#) [TCR3DF185,LM\(CT](#) [TCR3DF45,LM\(CT](#) [TLE4274 V50](#) [TLE4473G](#)
[V52](#) [059985X](#) [NCP4687DH15T1G](#) [701326R](#) [NCV8170AXV250T2G](#) [AP7315-25W5-7](#) [AP2111H-1.2TRG1](#) [ZLDO1117QK50TC](#)
[AZ1117ID-ADJTRG1](#) [TCR3DG12,LF](#) [MIC5514-3.3YMT-T5](#) [SCD7912BTG](#) [NCP154MX180270TAG](#) [SCD33269T-5.0G](#)
[NCV8170BXV330T2G](#) [NCV8170BMX330TCG](#) [NCV8170AMX120TCG](#) [NCP706ABMX300TAG](#) [NCP153MX330180TCG](#)
[NCP114BMX075TCG](#) [MC33269T-3.5G](#) [TCR3DG33,LF](#) [TCR4DG35,LF](#) [TAR5S15U\(TE85L,F\)](#) [TAR5S18U\(TE85L,F\)](#) [TCR3UG19A,LF](#)
[TCR4DG105,LF](#) [MPQ2013AGG-5-P](#) [NCV8170AMX360TCG](#) [TLE4268GSXUMA2](#) [NCP715SQ15T2G](#) [MIC5317-3.0YD5-T5](#)
[NCV563SQ18T1G](#) [NCP715MX30TBG](#) [NCV8702MX25TCG](#) [NCV8170BXV120T2G](#) [MIC5317-1.2YD5-T5](#) [NCV8170AMX150TCG](#)
[NCV8170BMX150TCG](#) [AP2213D-3.3TRG1](#) [NCV8170BMX120TCG](#) [NCV8170BMX310TCG](#) [NCV8170BMX360TCG](#)