

## Features

- SMD Active GNSS antenna module (GPS/GLONASS/GALILEO/BEIDOU)
- SAW filter on board
- Ultra-small SMD package; 7.0 x 7.0 x 0.9mm
- 1.5 to 3.3V supply
- Low power consumption

## Description

A compact Active GNSS antenna module using a high performance LNA with SAW for optimum performance. The M20047-1 operates on a versatile 1.5 – 3.3V supply with low power consumption.

## Applications

- **Wearable devices**
- **Portable Devices**
- **Asset Tracking / Personal Safety**
- **Sport Cameras / Equipment**
- **Smart Watches**
- **Navigation devices**

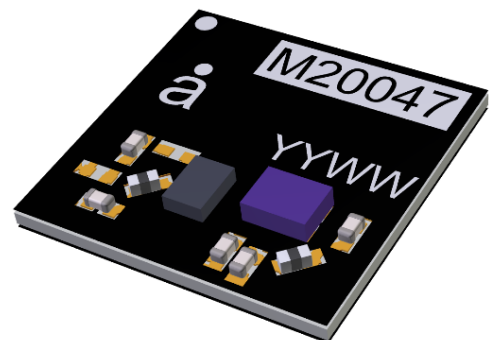

Antenova RADIONOVA

## Part number

M20047-1

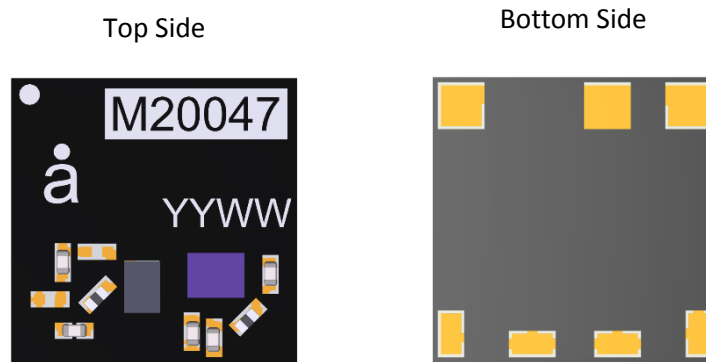

## Functional Block Diagram

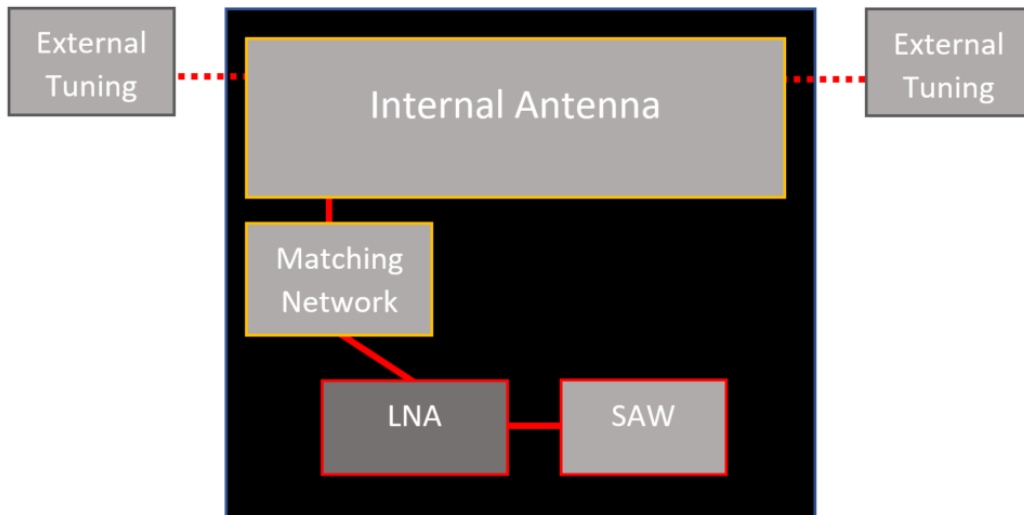

## Module Specifications

### Absolute Maximum Ratings

Symbol	Parameter	Min	Max	Unit
$V_{CC}$	DC Supply Voltage	-0.3	3.6	V
$RF_{IN}$	Maximum RF Input Power	N/A	0.0	dBm
$T_{STG}$	Storage Temperature	-40	+85	°C
$T_A$	Operating Temperature	-40	+85	°C

\* Exposure to absolute ratings may adversely affect reliability and may cause permanent damage.

### Recommended Operating Conditions

Symbol	Parameter	Min	Typ	Max	Unit
$V_{CC}$	DC Supply Voltage	1.5	-	3.3	V
$T_{OP}$	Operating Temperature	-40	-	+85	°C

### DC Electrical Characteristics

Conditions: V

$$= 2.8V, T_{OP} = 25\text{ }^{\circ}\text{C}$$

Symbol	Parameter	Typ	Unit
$I_{CC(AVG)}$	Supply Current (On Mode)	2.6	mA

### RF Specifications

Conditions: V

$$= 2.8V, T = 25\text{ }^{\circ}\text{C}, \text{Freq} = 1575.420\text{MHz}$$

Symbol	Parameter	Typ	Unit
Gain <sub>LNA</sub>	LNA Insertion Power Gain	18.5	dB
NF	Noise Figure	0.9	dB
ANT <sub>RL</sub>	Antenna Return Loss	<-10.3	dB
ANT <sub>BW</sub>	Antenna Bandwidth at -10dB Return Loss	62	MHz
ANT <sub>EFF</sub>	Antenna Total Efficiency	65	%
ANT <sub>EFF_RHCP</sub>	Antenna RHCP Efficiency	33	%

## Band Rejection

Frequency	Standard	Typ*	Unit
698-798	LTE700	48	dB
824-849	Cellular CDMA	47	dB
869-894	GSM850	48	dB
880-915	GSM900	48	dB
1710-1785	GSM1800/DCS	42	dB
1850-1910	GSM1900/PCS	43	dB
1920-1980	WCDMA	42	dB
2400-2492	WLAN, BT and WiMAX	33	dB
2500-2690	LTE2600	33	dB

\*Does not include antenna rejection.

## Mechanical Specifications

Parameter	Typ	Unit
Module exterior dimensions (L x W x H)	7.0 (±0.1) x 7.0 (±0.1) x 0.9 (+0.2 / - 0.0)	mm
Module support and connection	Surface mounted (SMD)	-
Module mass	<2	g

## Pin out Description

Table shows the designation and function of each pin on the M20047-1 module.

Pin	Designator	Description
1	AT1	Ground connection
2	GND	Ground connection
3	GND	Ground connection
4	GND	Ground connection
5	RFO/VCC	RF Signal Output / DC Voltage Input
6	AT2	Antenna Tuning 2
7	NC	Not Connected

## Schematic symbol of module

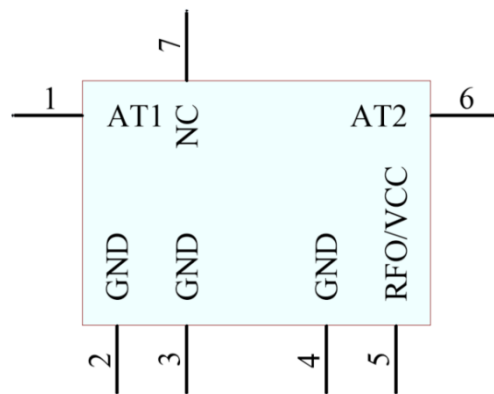

## Mechanical

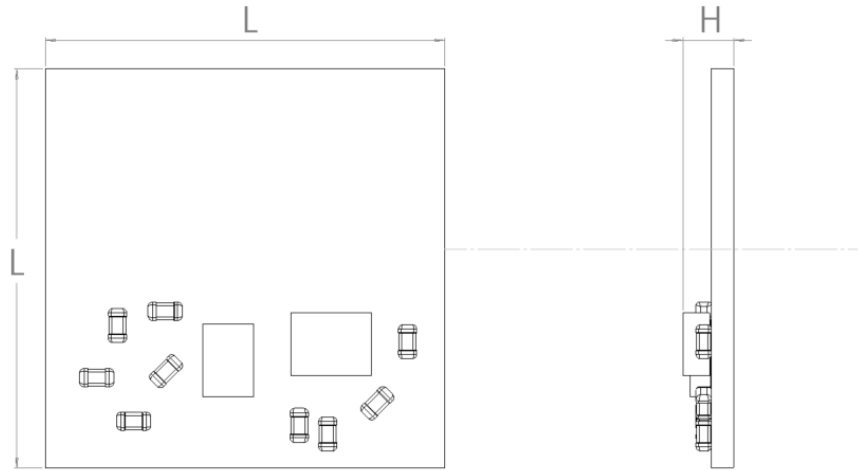

All dimensions in mm

L	W	H
<b>Length</b>	<b>Width</b>	<b>Height</b>
7.0 ±0.1	7.0 ±0.1	0.9 +0.2 / - 0.0

BOTTOM SIDE

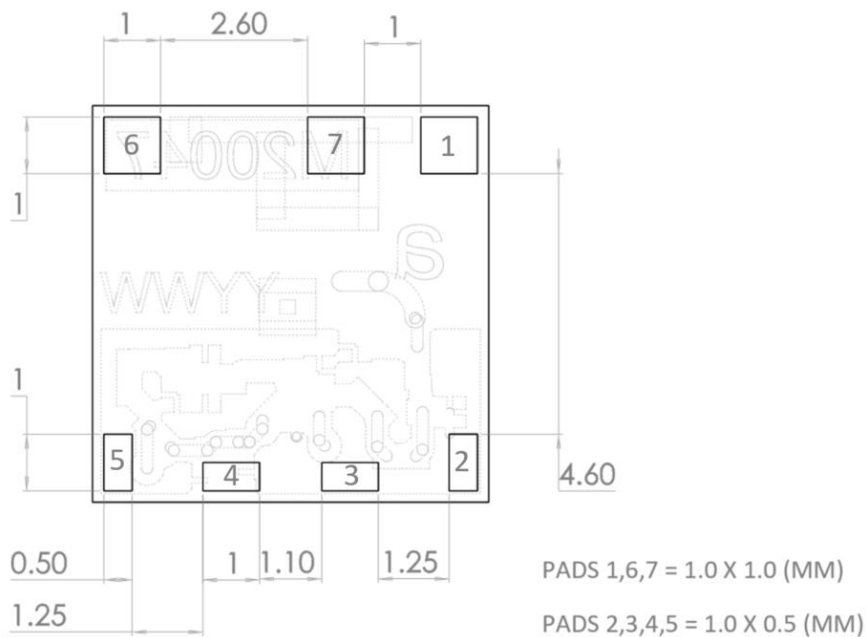

All dimensions in mm

## Module Host PCB Footprint

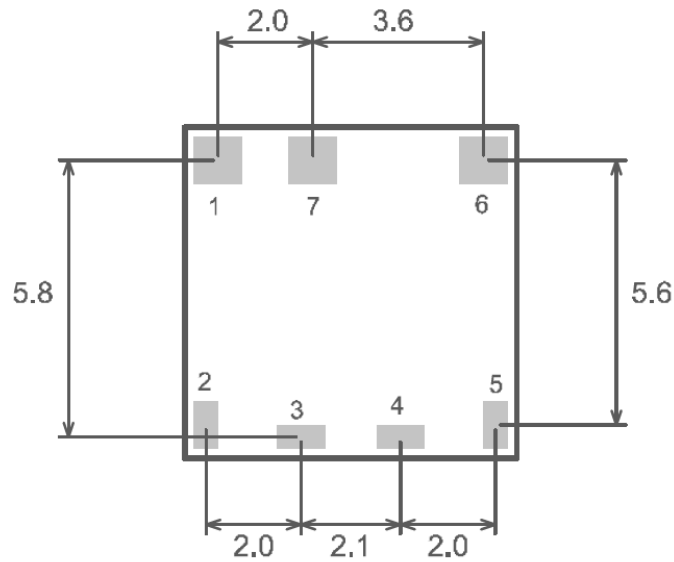

PADS 1,6,7 = 1.0 x 1.0 (mm)  
PADS 2,3,4,5 = 1.0 x 0.5 (mm)

All dimensions in mm

## Application Schematic

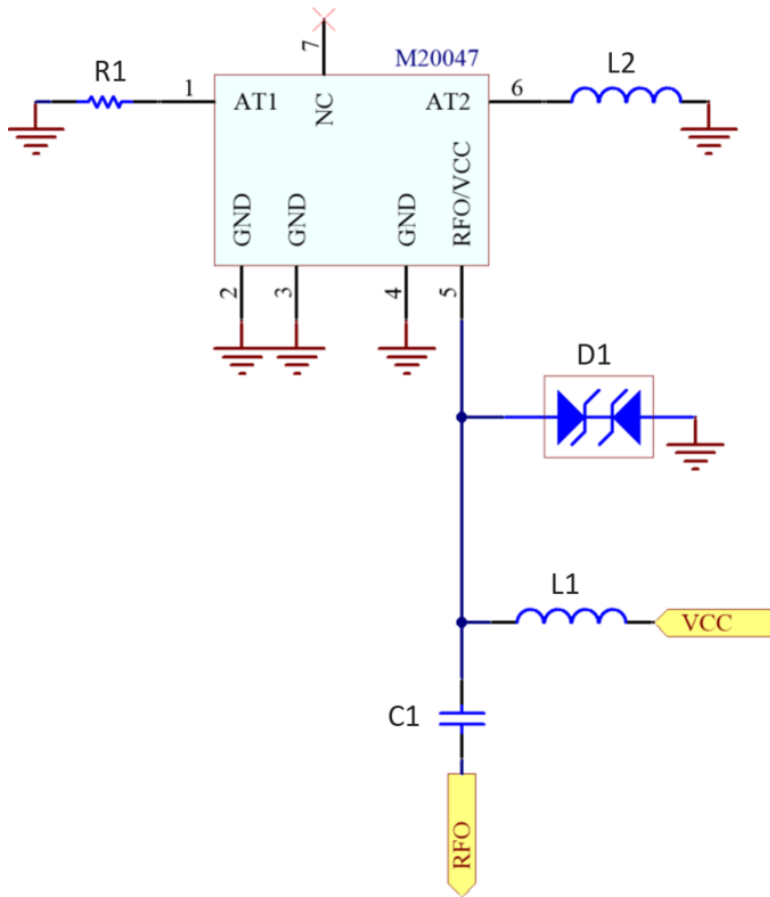

## Bill of Materials

Designator	Value	Description/Comments	Quantity
M20047-1	NA	Active GNSS Module	1
D1	ESD Diode	TVS 20kV ESD protection (Non-specific)	1
L1	47nH Inductor	RF choke	1
C1	22pF Capacitor	DC blocking Capacitor	1
L2	TBD	Antenna tuning (Value dependent on host PCB)	1
R1	Resistor	For additional antenna tuning	1



## Front-end Rejection

The figure below shows the rejection for the input SAW filter after the LNA, including the effect of pads, tracks. The plot can be useful to calculate the isolation required from adjacent transmitters in order to avoid the saturation of the LNA.

Input SAW Rejection – Wideband

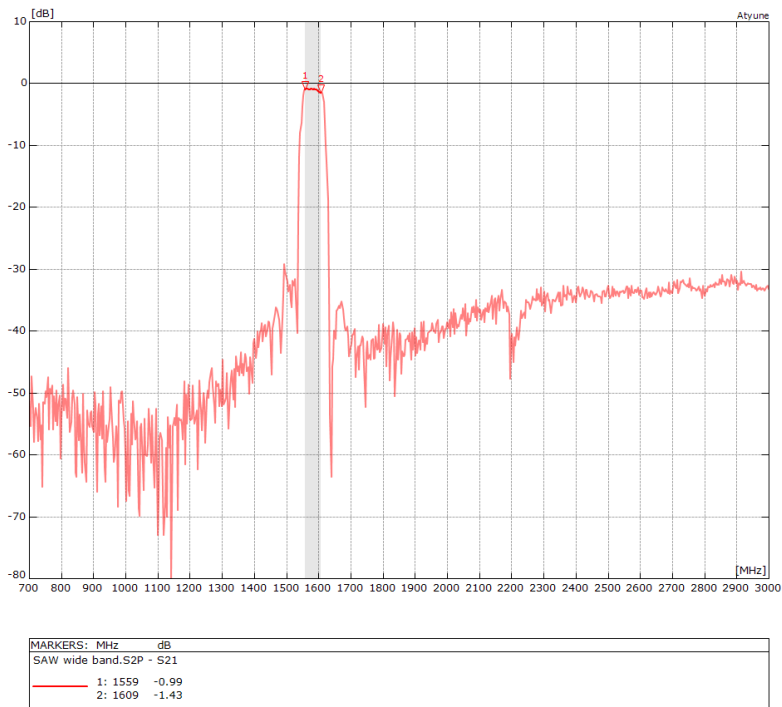

Input SAW Rejection - Narrowband

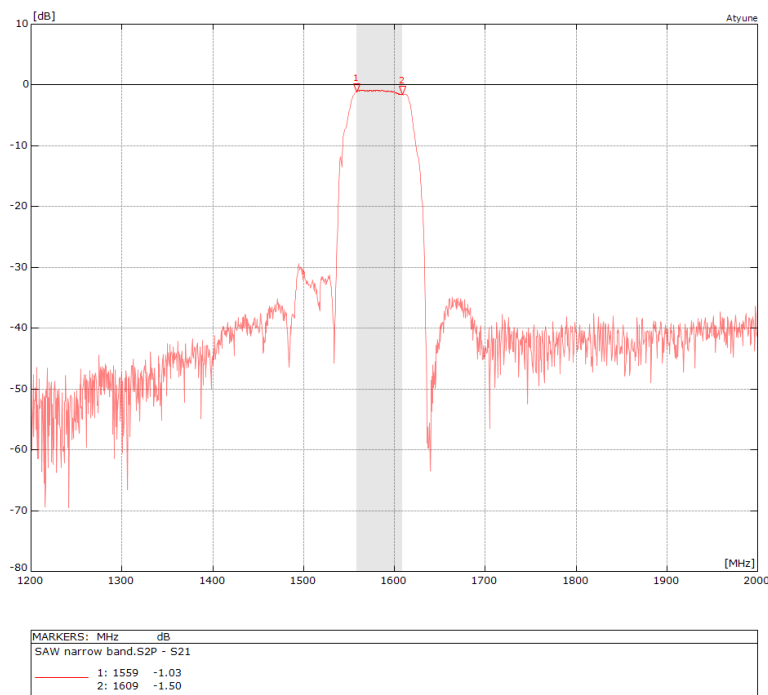

## RF Performance

### Return Loss

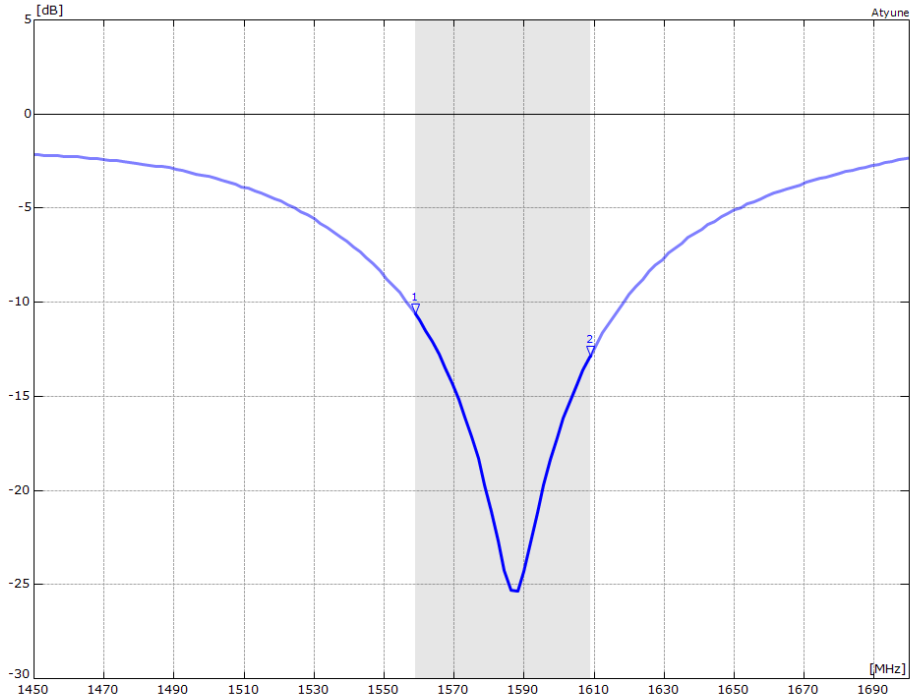

### VSWR

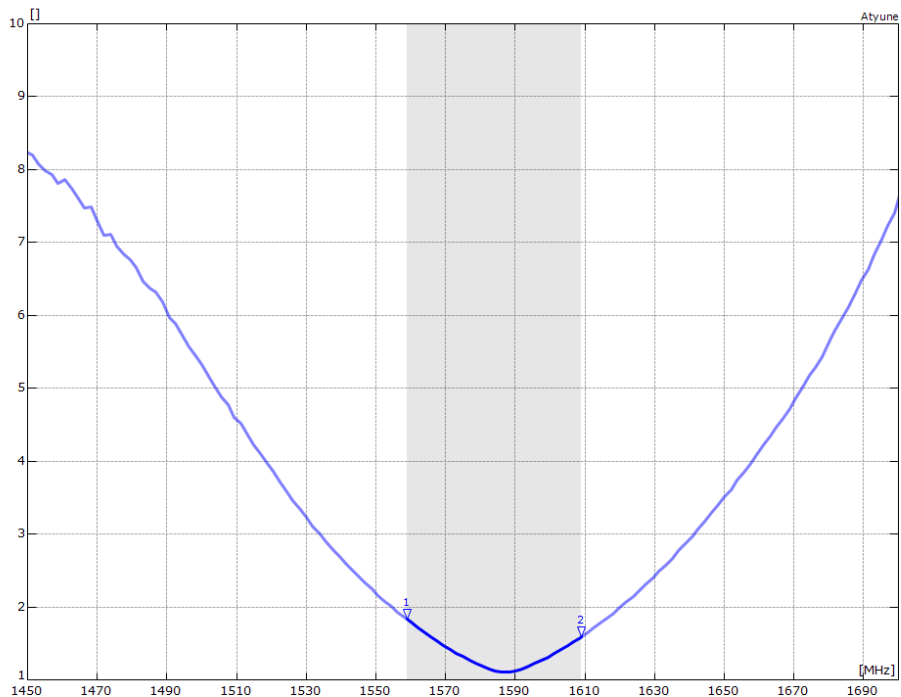

## Antenna Pattern 1559 MHz – 1609MHz

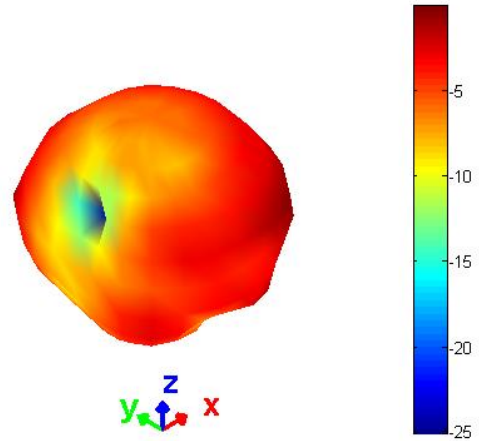
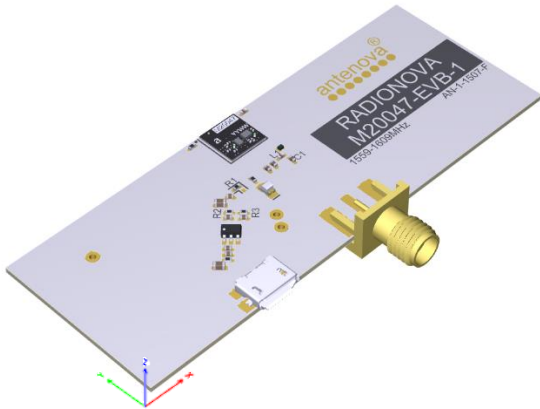

### 3D pattern at 1575 MHz

*Drag to rotate pattern and PCB by using Adobe Reader*

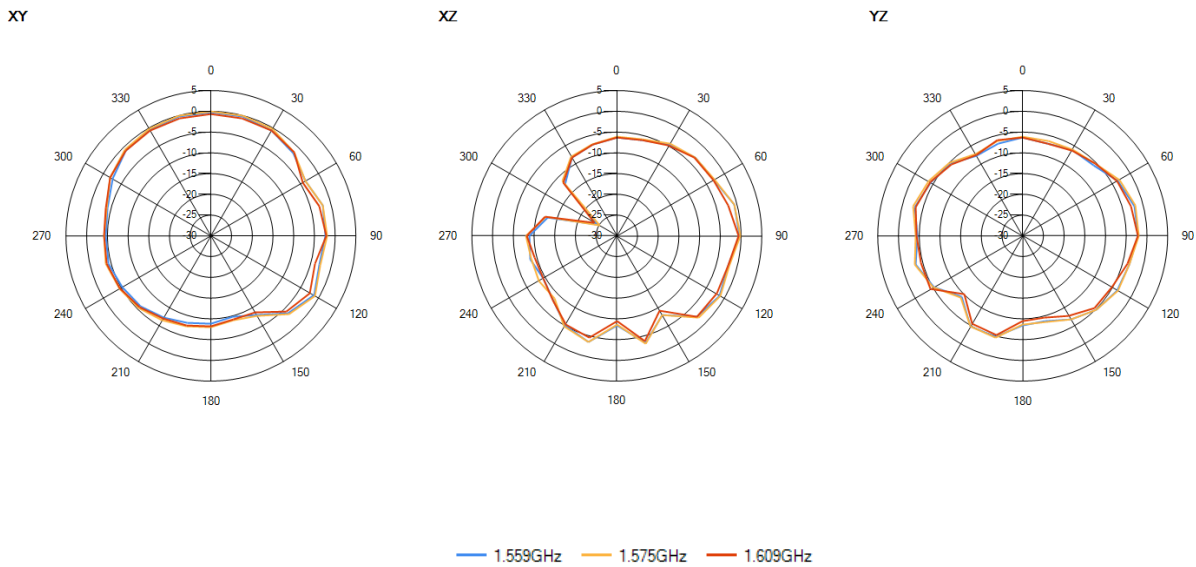

## Module Integration Guide

### Placement

Due to the internal antenna, care must be taken when defining the placement of the module on the host PCB. Here are some guidelines that should be used when deciding the position of the module.

- The module top edge must be placed almost level with the edge of the host PCB
- The edge of the host PCB that the module is to be placed at must be a minimum of 40mm in length.

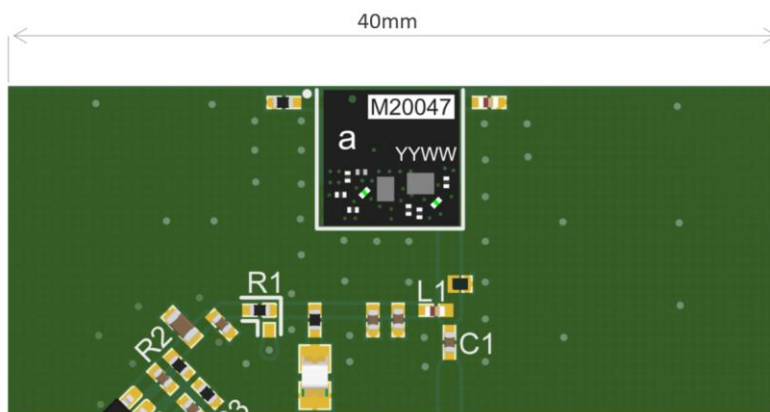

- The central placement of the module is advised. However, an offset placement is also possible.
- For an offset closer to the PCB edge to the right side of the module, a minimum of 10mm distance is required to the edge of the host PCB.

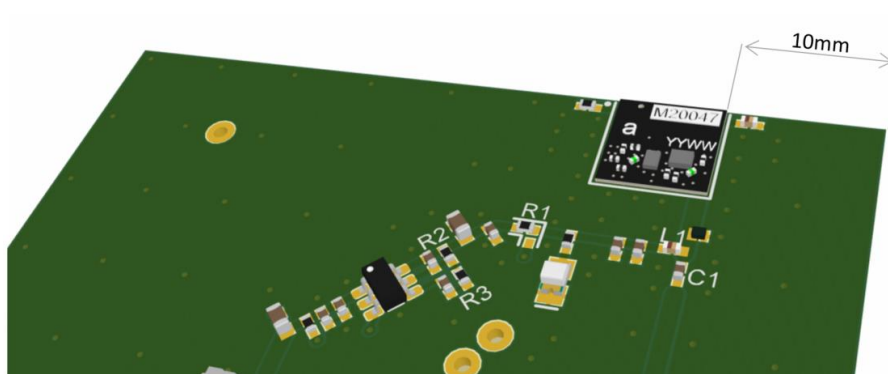

- The antenna uses the host PCB ground to effectively radiate. As such, a GND plane must be placed on the host PCB on at least two layers.
- In the example below, the only area void of GND is the antenna keep-out area. The solder mask is removed to make the copper visible.

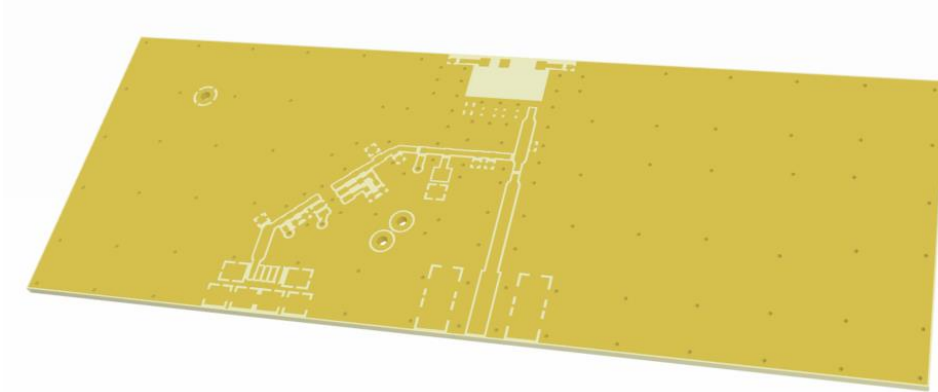

- An ideal stack-up for a host PCB would be to use the top and bottom layers as GND planes, while using the internal layers for any signal and power planes. This not only helps the GPS antenna to perform effectively, but also helps to reduce any potential noise issues that can be associated with mixed signal PCB's.
- An example below shows a 4-layer host PCB, GND flooding all available space not used by signals or components.

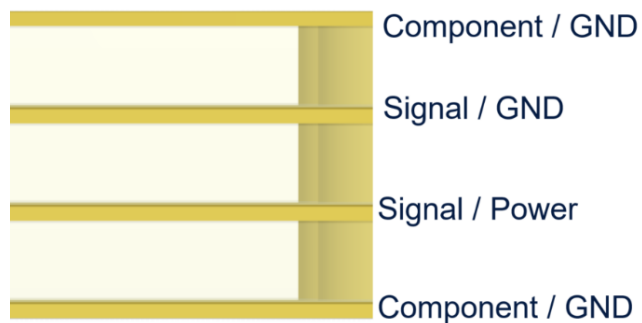

*Please contact Antenova for advice on placement.*

## Antenna Clearance Area

The M20047-1 modules internal antenna requires a small clearance on the host PCB to operate. The clearance means that no Ground or tracks of any kind can be within this area. This must also be clear through the entire PCB stack up. The minimum area needed clear is 7.0 X 5.0 (mm).

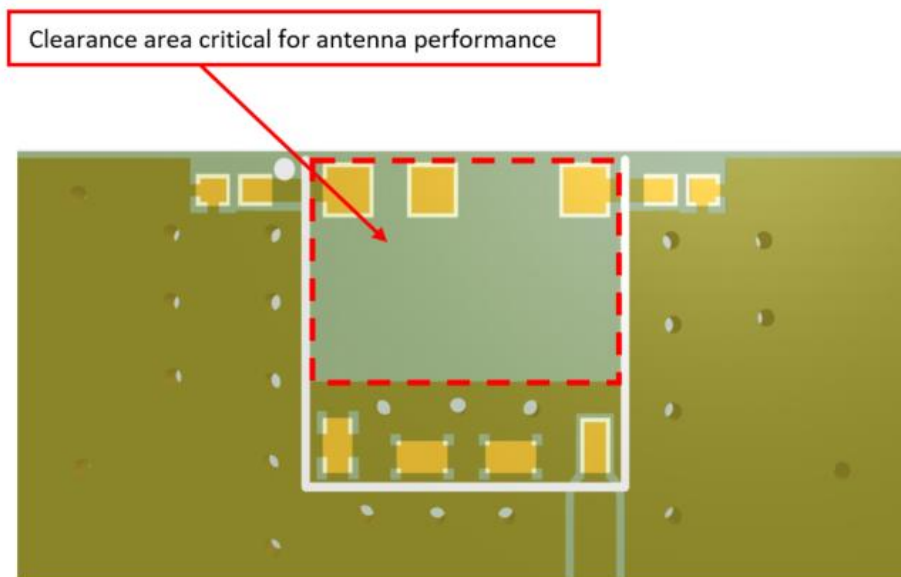
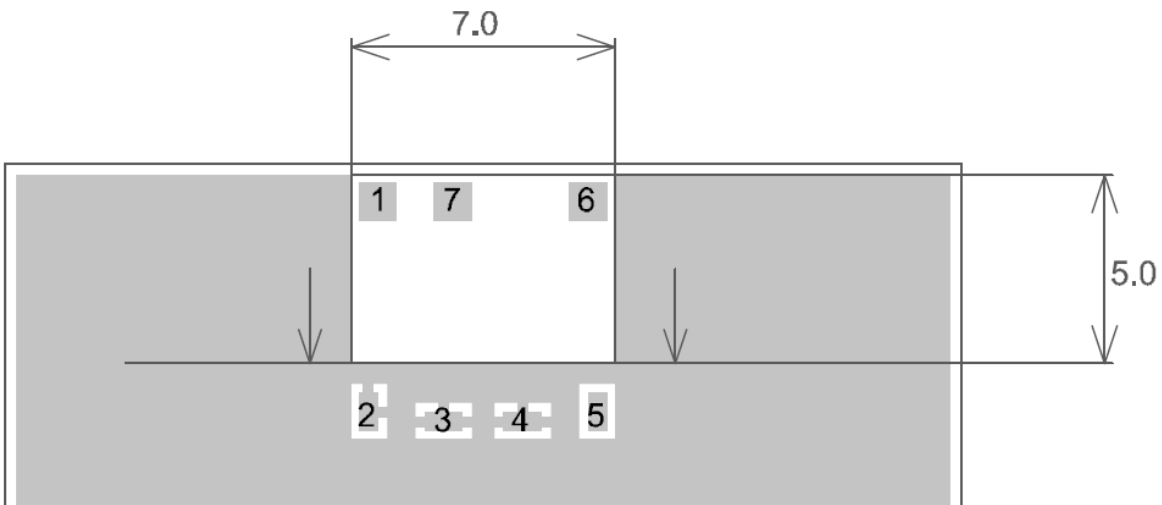

## External Matching

The M20047-1 module uses matching circuit components on the host PCB to fine-tune the on-board antenna to each specific application. This “external matching” allows compensating for the detuning of the antenna caused by various components that can be close to the M20047-1 module in the actual application (plastic case, battery, speakers etc).

The external matching must be placed on the host PCB from pads AT1(Pad 1) and AT2 (Pad 6). A single component from each pin to GND is all that is required. This should be placed close to the modules pads.

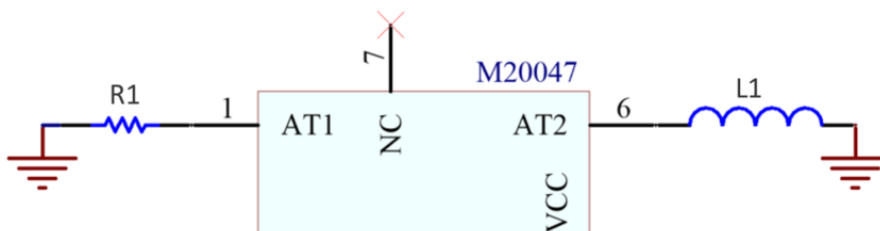

In the example above AT1 only required a 0R resistor and AT2 uses a small value inductor to tune the antenna. Both components should be designed in as both may be required for the intended device.

### Type of Matching Components

- Capacitors: Use 0402, COG components
- Inductors: High-Q, wire wound inductors in 0402 sizes are recommended for maximum performance, e.g. Murata LQW15 series
- Good quality multi-layer type inductors (e.g. Murata LQG15 series) can also be used as a lower cost alternative

## Evaluation Kit

The EVK is a single PCB that contains the module and required components to operate. The supply is driven from either a USB supply or on-board battery.

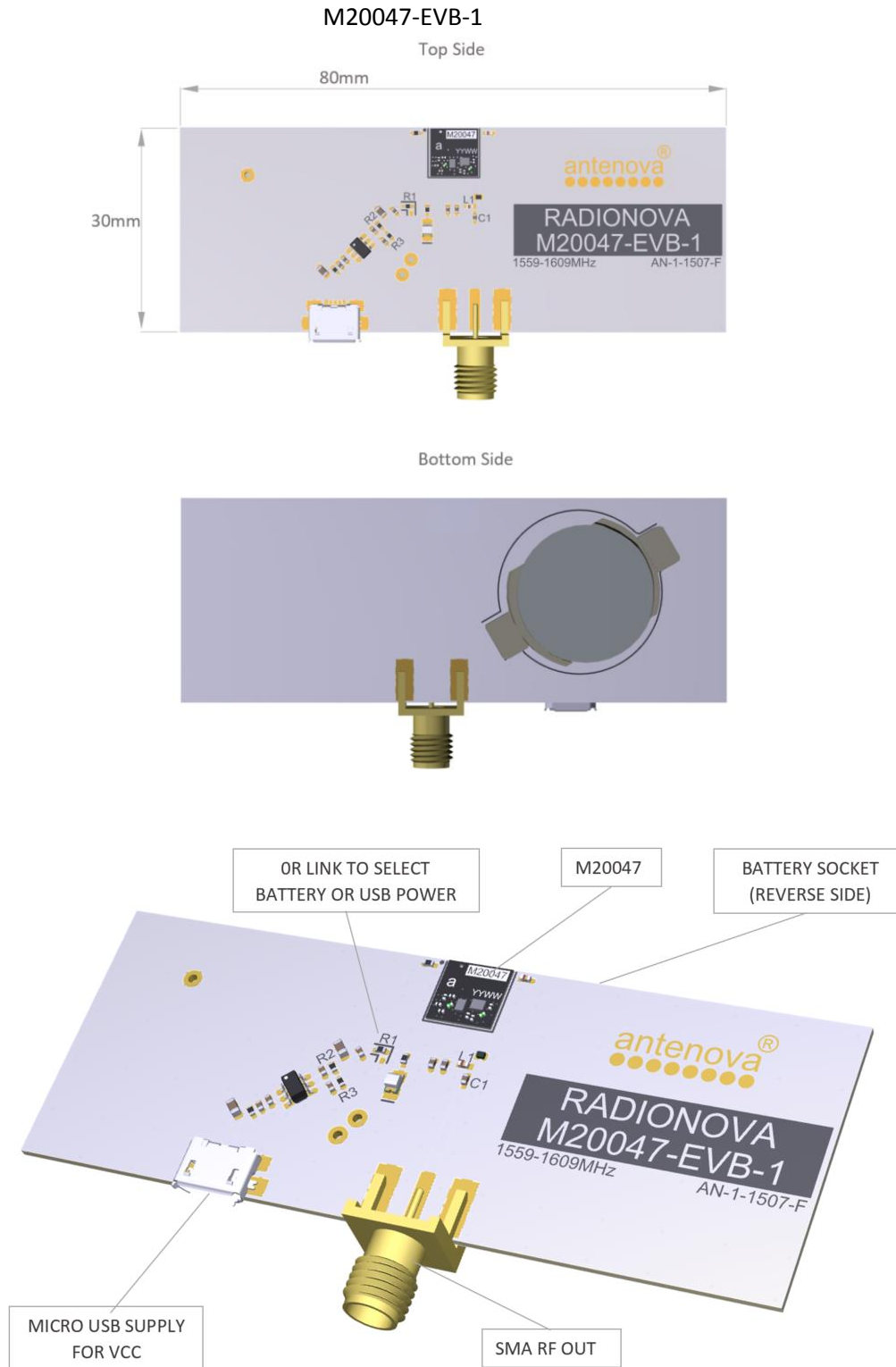



## Reflow Soldering

### Placement

Typical placement systems used for any LGA package are acceptable.

### Soldering Paste

Use of “No Clean” soldering paste is strongly recommended, as it does not require cleaning after the soldering process has taken place. An example of suitable soldering paste is Alpha OM350.

### Soldering

The recommended soldering profile for M20047-1 is shown below. However, it is the responsibility of the Contract Manufacturer to determine the exact reflow profile used, taking into consideration the parameters of the host PCB, solder paste used, etc.

Profile Feature		Pb-Free Solder
Pre-Heat	Temperature ( $T_s$ ) Min	130°C
	Temperature ( $T_s$ ) Max	220°C
	Time ( $t_s$ )	<150s
Reflow	Liquidus Temperature - ( $T_l$ )	220°C
	Time ( $t_l$ )	45-90s
Peak Package Body Temperature ( $T_p$ )		245°C
Time within 5°C of peak temp ( $t_p$ )		30s
Average Ramp up rate - $T_s(\text{max})$ to ( $T_p$ )		3°C/s
Ramp Down Rate		6°C/s max

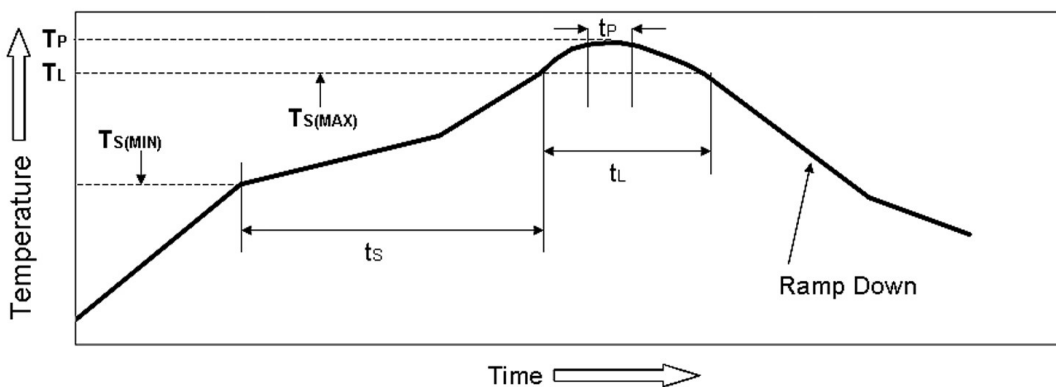

Example Reflow profile

The Pb Free Process-Package Peak Reflow Temperature is 260°C.

**Exceeding the maximum soldering temperature could permanently damage the module.**

## Multiple Soldering

The M20047-1 module can be submitted up to 2 reflow soldering processes.

Upside-down soldering is acceptable, but it is recommended that the Contract Manufacturer qualify the process before mass production. The second reflow must take place within the recommended floor life limit (MSL3). Please contact Antenova for further information.

## Quality and Environmental Specifications

Test	Standard	Parameters
PCB Inspection	IPC-6012B, Class 2. Qualification and Performance Specification for Rigid Printed Boards - Jan 2007	
Assembly Inspection	IPC-A-610-D, Class 2 "Acceptability of electronic assemblies"	
Temperature Range	ETSI EN 300 019-2-7 specification T 7.3	-30 °C, +25 °C, +85 °C, operating
Damp Heat	ETSI EN 300 019-2-7 specification T 7.3	+70 °C, 80% RH, 96 hrs, non-operating
Thermal Shock	ETSI EN 300 019-2-7 specification T 7.3 E	-40 °C ... +85 °C, 200 cycles
Vibration	ISO16750-3	Random vibration, 10~1000Hz, 27.8m/s <sup>2</sup> , 8hrs/axis, X, Y, Z 8hrs for each 3 axis non-operating
Shock	ISO16750-3	Half-sinusoidal 50g, 6ms, 10time/face, ±X, ±Y and ±Z non-operating
Free Fall	ISO16750-3	1m height, 2 drops on opposite side
ESD Sensitivity	JEDEC, JESD22-A114 ESD Sensitivity Testing Human Body Model (HBM), Class 2 JEDEC, JESD22-A115 ESD Sensitivity Testing Machine Model (MM), Class B	+2000V - Human hand assembly +200V - Machine automatic final assembly
Shear	IEC 60068-2-21, Test Ue3: Shear	Force of 5N applied to the side of the PCB
Moisture/Reflow Sensitivity	IPC/JEDECJ-STD-020D.1	MSL3
Storage (Dry Pack)	IPC/JEDECJ-STD-033C	MSL3
Solderability	EN/IEC 60068-2-58 Test Td	More than 90% of the electrode should be covered by solder. Solder temperature 245 °C ± 5 °C

### Moisture Sensitivity

Antenova ships all devices dry packed in tape on reel with desiccant and moisture level indicator sealed in an airtight package. If on receiving the goods the moisture indicator is pink in colour or a puncture of the airtight seal packaging is observed, then follow J-STD-033 "Handling and Use of Moisture/Reflow Sensitive Surface Mount Devices".

## Optimal Storage Conditions

Temperature	-10°C to 40°C
Humidity	Less than 75% RH
Shelf life	24 months
Storage place	Away from corrosive gas and direct sunlight
Packaging	Reels should be stored in unopened sealed manufacturer's plastic packaging

### Storage (Out of Bag)

The M20047-1 modules meet MSL Level 3 of the JEDEC specification J-STD-020D - 168 hours Floor Life (out of bag)  $\leq 30$  °C/60% RH. If the stated floor life expires prior to reflow process, then follow J-STD-033 "Handling and Use of Moisture/Reflow Sensitive Surface Mount Devices".

## Hazardous material regulation conformance

The RF antenna module meets RoHS requirements.

## Packaging

### Tape Characteristics

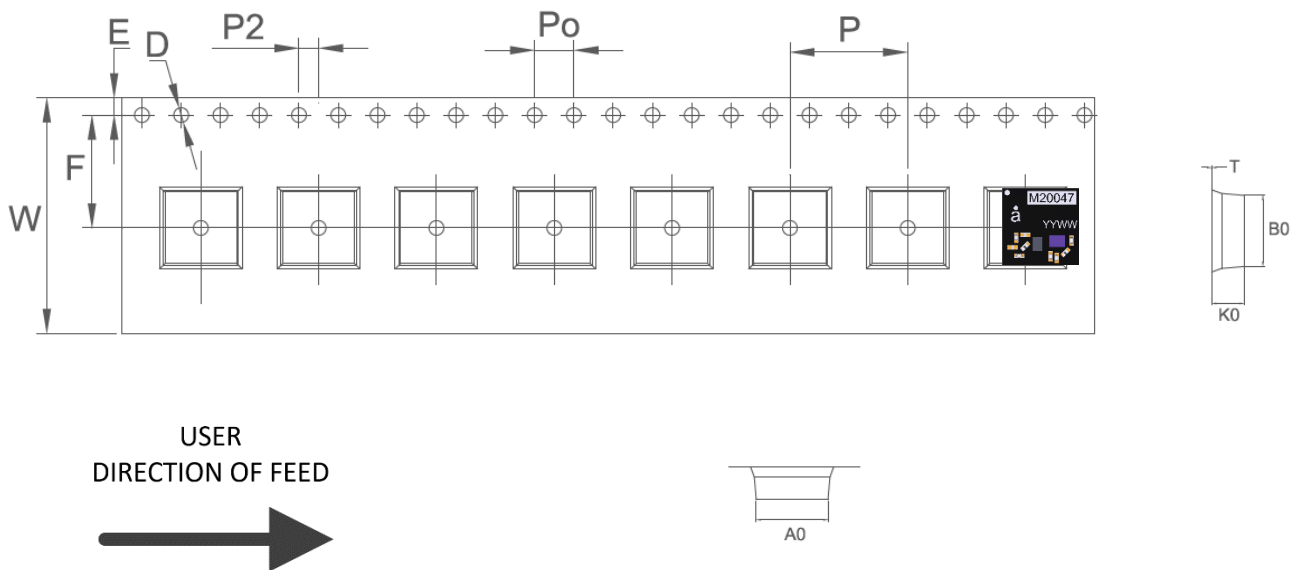

W	F	E	P0	P	P2
24.00 ±0.3	11.50 ±0.1	1.75 ±0.1	4.00 ±0.1	12 ±0.1	2.00 ±0.1
D	B0	T	K0	A0	
1.55 ±0.1	7.30 ±0.1	0.30 ±0.05	3.30 ±0.1	7.30 ±0.1	

Dimensions in mm

Quantity	Leading Space	Trailing Space
1000 pcs / reel	50 blank module holders	50 blank module holders

Reel Dimensions

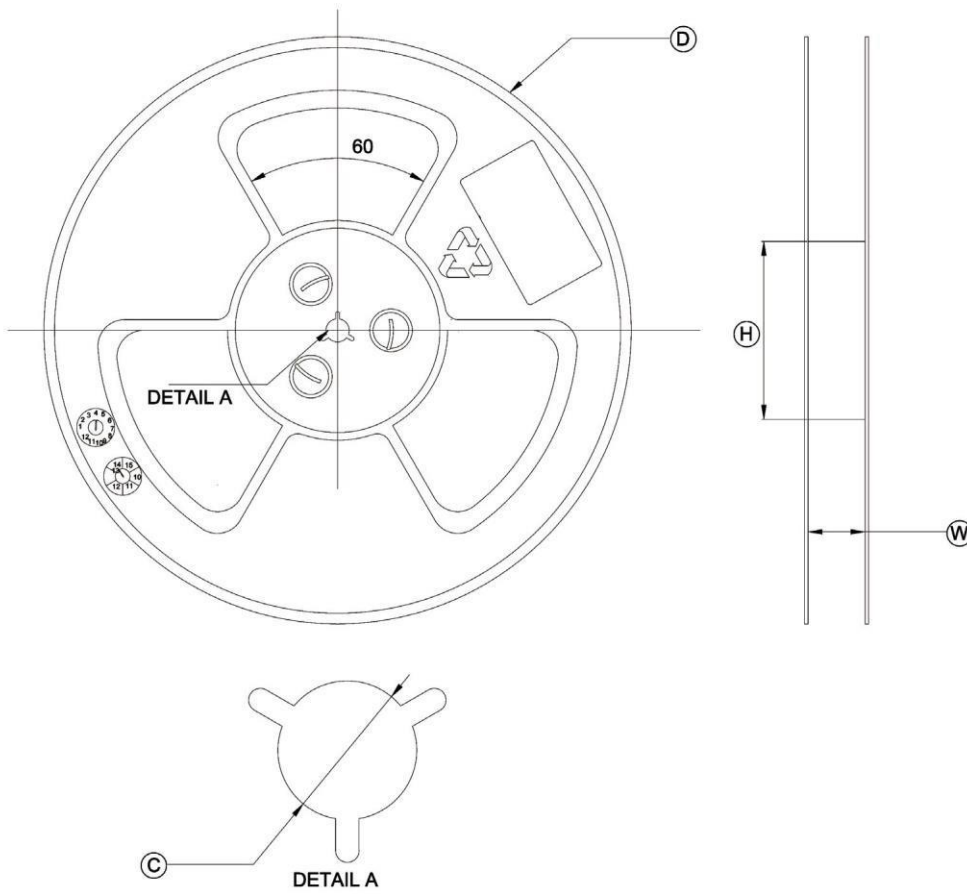

Width (W)	Reel Diameter (D)	Hub Diameter (H)	Shaft Diameter (C)
24.4mm +0.2/-0.2	330.0mm +0.0/-2.0	100.0mm +3.0/-3.0	13.3mm +0.3/-0.3

## Box Dimensions

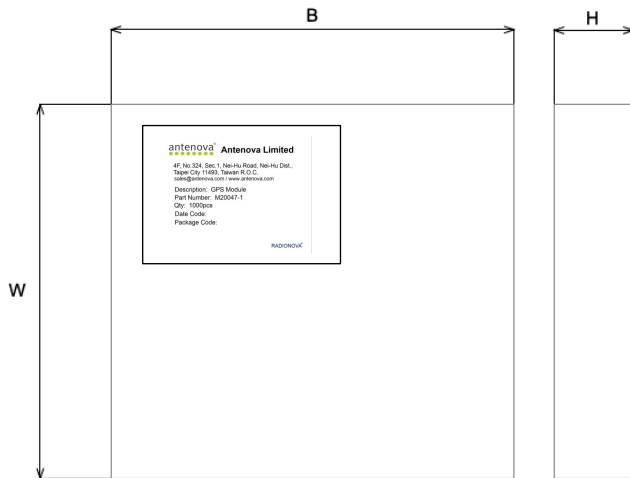

Width (W)	Breadth (B)	Thickness (H)
358mm	350mm	73mm

## Bag Properties

Reels are supplied in protective plastic packaging.

## Reel Label Information

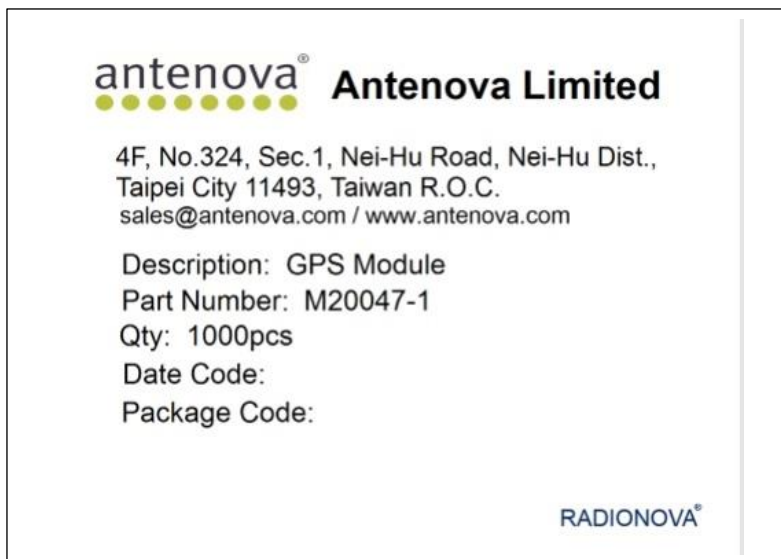

## Quality statements

Antenova's products conform to REACH and RoHS legislation. For our statements regarding these and other quality standards, please see [www.antenova.com](http://www.antenova.com).



## Antenna design, integration and test resources

Product designers – the details contained in this datasheet will help you to complete your embedded antenna design. Please follow our technical advice carefully to obtain optimum antenna performance.

It is our goal that every customer will create a high performing wireless product using Antenova's antennas. You will find a wealth of design resources, calculators and case studies to aid your design at our website.

Antenova's design laboratories are equipped with the latest antenna design tools and test chambers. We provide antenna design, test and technical integration services to help you complete your design and obtain certifications.

If you cannot find the antenna you require in our product range, please contact us to discuss creating a bespoke antenna to meet your requirement exactly.

## Contacts

Join our online antenna design community: [ask.antenova.com](http://ask.antenova.com)

Order antenna samples and evaluation boards at: [www.antenova.com](http://www.antenova.com)

Request a quotation for antennas by volume: [sales@antenova.com](mailto:sales@antenova.com)

Global Headquarters:

**Antenova Ltd, 2<sup>nd</sup> Floor Titan Court, 3 Bishop Square,  
Hatfield, AL10 9NA +44 (0) 1223 810600**

**Copyright® Antenova Ltd.** All Rights Reserved. Antenova®, gigaNOVA®, RADIONOVA®, the Antenova product family names and the Antenova logos are trademarks and/or registered trademarks of Antenova Ltd. Any other names and/or trademarks belong to their respective companies. The materials provided herein are believed to be reliable and correct at the time of printing. Antenova does not warrant the accuracy or completeness of the information, text, graphics or other items contained within this information. Antenova further assumes no responsibility for the use of this information, and all such information shall be entirely at the user's risk.



## X-ON Electronics

Largest Supplier of Electrical and Electronic Components

*Click to view similar products for [Antennas](#) category:*

*Click to view products by [Antenova](#) manufacturer:*

Other Similar products are found below :

[GAN30084EU](#) [930-033-R](#) [GW17.07.0250E](#) [1513563-1](#) [EXE902SM](#) [APAMPG-117](#) [MAF94383](#) [W3908B0100](#) [W6102B0100](#) [YE572113-30RSMM](#) [108-00014-50](#) [66089-2406](#) [SPDA17RP918](#) [A09-F8NF-M](#) [A09-F5NF-M](#) [RGFRA1903041A1T](#) [W3525BW100](#) [W3593B0100](#) [W3921B0100](#) [SIMNA-868](#) [SIMNA-915](#) [SIMNA-433](#) [W1044](#) [W1049B090](#) [A75-001](#) [WTL2449CQ1-FRSMM](#) [CPL9C](#) [EXB148BN](#) [0600-00060](#) [TRA9020S3PBN-001](#) [GD5W-28P-NF](#) [MA9-7N](#) [GD53-25](#) [GD5W-21P-NF](#) [EXB144SM](#) [C37](#) [MAF94051](#) [GD35-17P-NF](#) [P1744](#) [MA9-5N](#) [EXD420PL](#) [B1322NR](#) [QWFTB120](#) [MAF94271](#) [MAF94300](#) [GPSMB301](#) [FG4403](#) [AO-AGSM-OM54](#) [5200232](#) [MIKROE-2349](#)