

## Zoma

Part No. SR4T014

## TransferJet™ RF Coupler

lamiiANT<sup>®</sup>

Product Specification

### 1. Features

- Coupler for TransferJet applications
- Short range coupling device for secure data transfer
- Point to point connectivity
- SMD mounting
- Small low profile design
- Supplied on Tape and Reel
- Automotive temperature rating
- Compliant with Toshiba TransferJet™ hardware

### 2. Description

Zoma is intended for TransferJet Applications. This product specification shows the performance of the coupler to cover the TransferJet operating band (4.2 – 4.8 GHz). TransferJet is a close proximity wireless transfer technology providing a safe and quick transfer of data: 560Mbps (max.) / effective 375Mbps (data throughput). The system is capable of selecting the appropriate transmission rate depending on the wireless environment.

### 3. Applications

- Handsets
- PC / Laptops / Tablets
- Cameras
- Water resistant devices with no visible ports
- Machine to Machine



*Patent Pending*

## 4. Part Number

Zoma: SR4T014



## 5. General Data

Product name	Zoma
Part Number	SR4T014
Frequency	4.2 – 4.76 GHz
Polarization	Linear
Operating temperature	-40°C to 140°C
Environmental condition test	ISO 16750-4 5.1.1.1/5.1.2.1/5.3.2
Impedance with matching	50 Ω
Weight	< 0.1 g
Coupler type	SMD
Dimensions (Coupler)	4.0 x 4.0 x 0.4 (mm)

## 6. RF Characteristics

	4.2 – 4.76 GHz
S <sub>21</sub> at 4.48GHz (1cm distance)	-22.0 dB (typ)
Coupler BW (3dB Bandwidth)	560 MHz

## 7. RF Performance

### 7.1 S21 – Planar

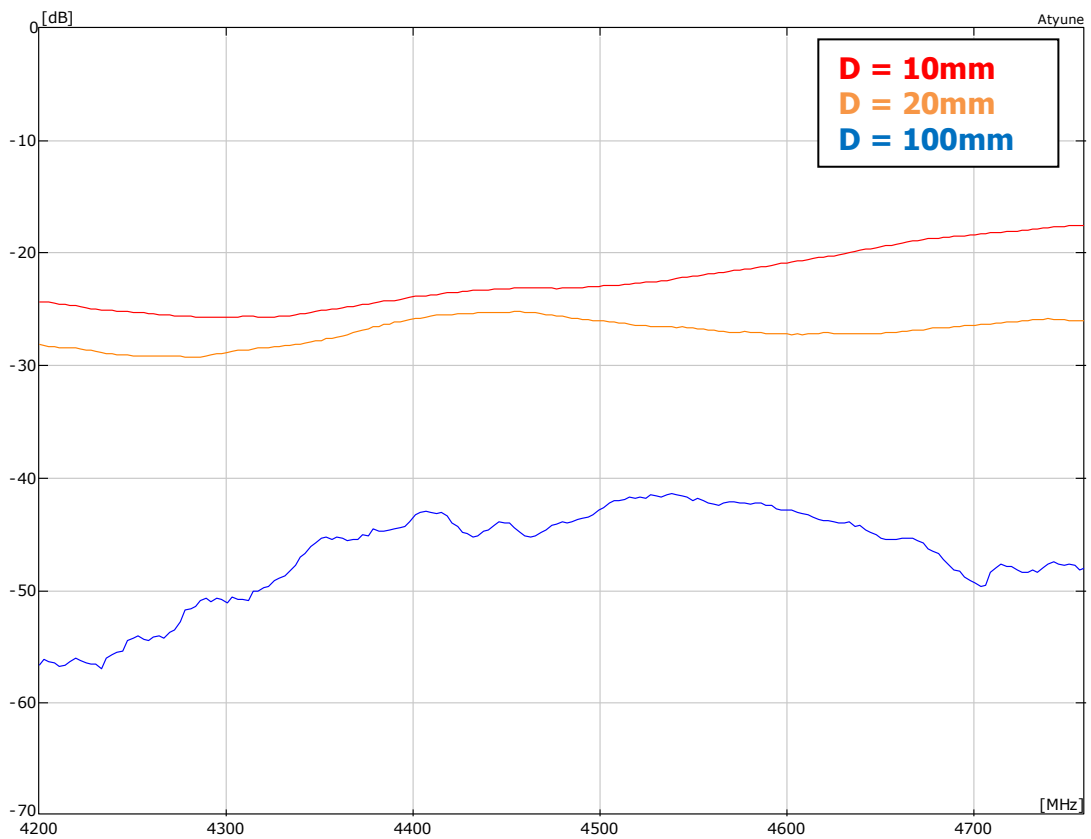
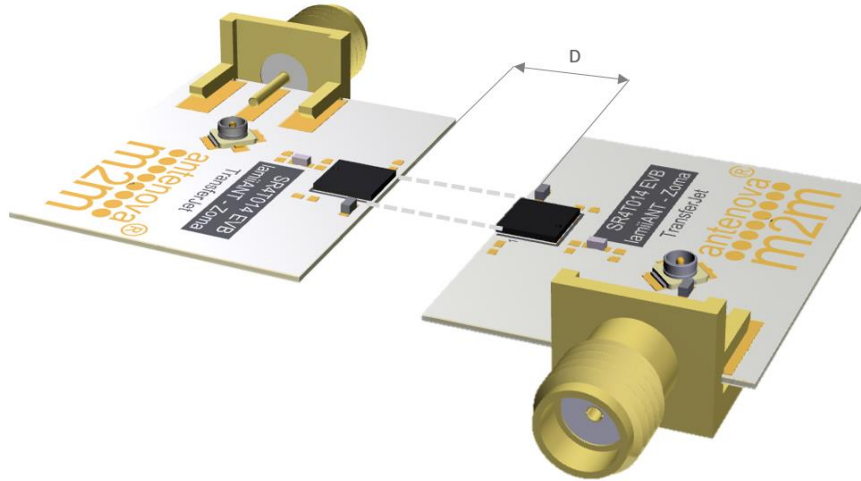

## 7.2 S21 – Co-planar

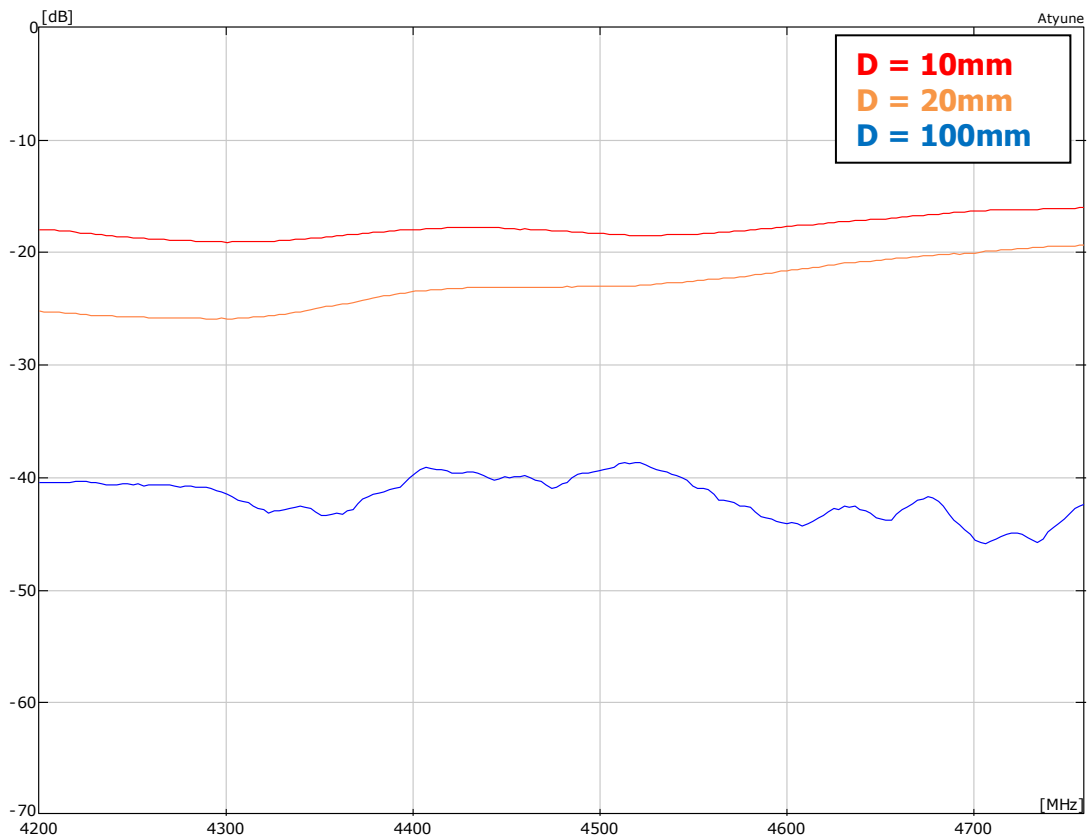
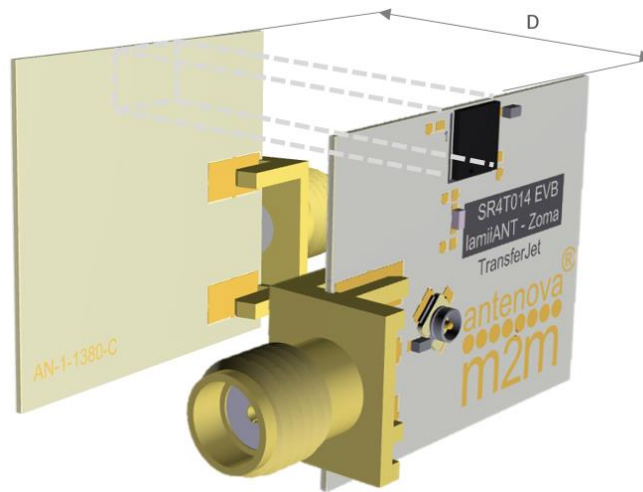

## 8. Coupler Dimensions

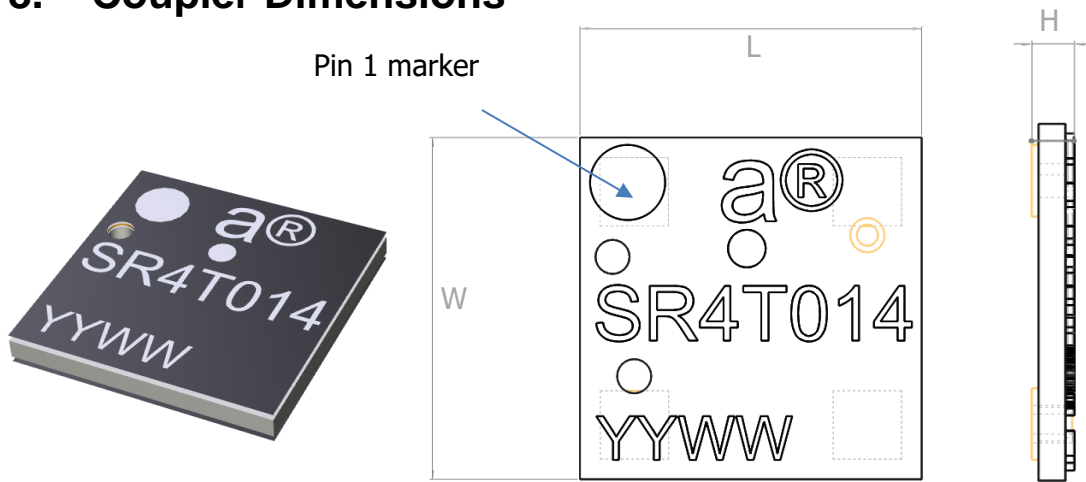

L	W	H
Length	Width	Height
4.0	4.0	0.4

All dimensions in mm

### Bottom side dimensions

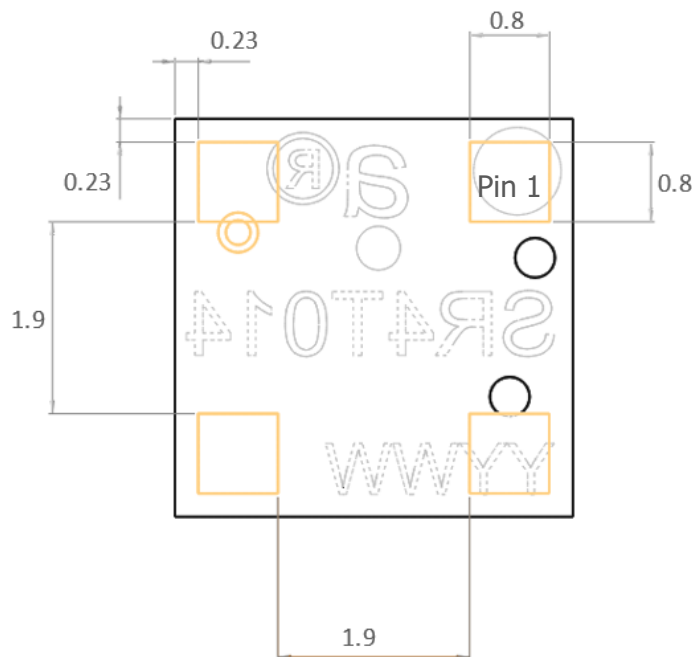

4 solder pads (0.8 x 0.8 mm)

## 9.0. Coupler definition

### 9.1 Schematic symbol and pin definition

The circuit symbol for the coupler is shown below.

Pin	Description
1,3	Additional tuning/NC
2	Feed
4	GND

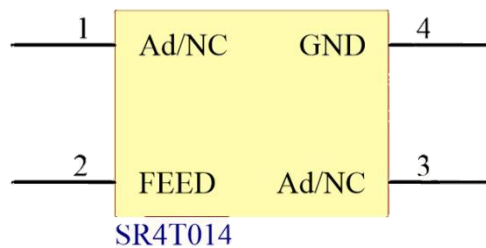

### 9.2 Footprint

The recommended host PCB footprint is below. All dimensions in (mm)

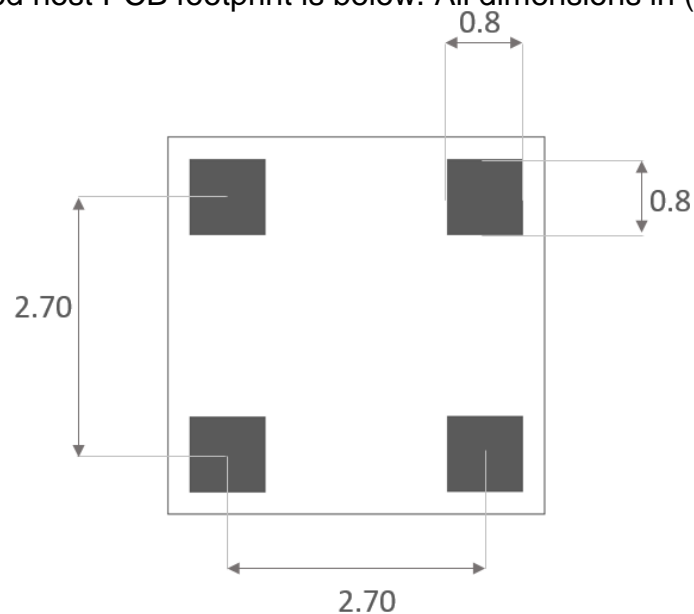

## 10.0 Electrical Interface

### 10.1 Transmission Line

All transmission lines should be designed to have a characteristic impedance of 50Ω.

- The length of the transmission lines should be kept to a minimum
- Any other parts of the RF system like transceivers, power amplifiers, etc, should also be designed to have an impedance of 50 Ω

Once the material for the PCB has been chosen (PCB thickness and dielectric constant), a coplanar transmission line can easily be designed using any of the commercial software packages for transmission line design. For the chosen PCB thickness, copper thickness and substrate dielectric constant, the program will calculate the appropriate transmission line width and gaps on either side of the feed.

A DC blocking capacitor should be placed in line to protect the RF front end.

### 10.2 Matching circuit

The coupler requires a matching circuit that must be optimized for each product. The matching circuit will require up to four components and the following circuit should be designed into the host PCB. Not all components may be required but should be included as a precaution. The matching network must be placed close to the coupler feed to ensure it is more effective in tuning.

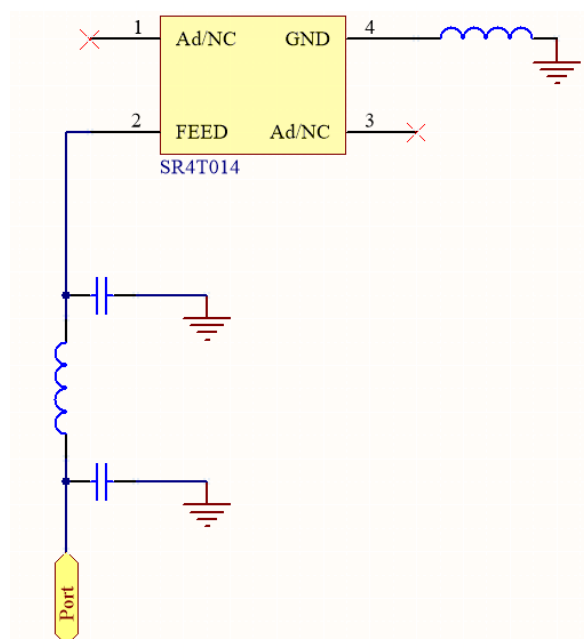

## 11.0 Coupler Integration Guide

### 11.1 Placement

Whichever size host PCB is used, the coupler should be placed on the edge of the PCB. GND should be flooded around the coupler to ensure the correct RF properties.

The coupler requires clearance ideally in 3 spatial directions as shown below.

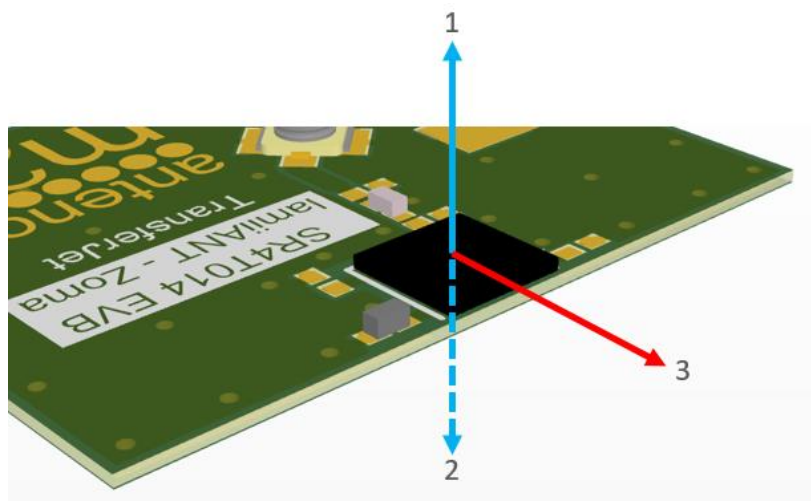

### 11.2 Host PCB Layout

The host PCB must ensure the footprint and clearance meets the coupler specification. An example of the PCB layout shows the coupler footprint with the required clearance. The coupler needs to be placed at the PCB edge, and the three other sides should have a clearance of 0.5mm greater than the coupler dimension.

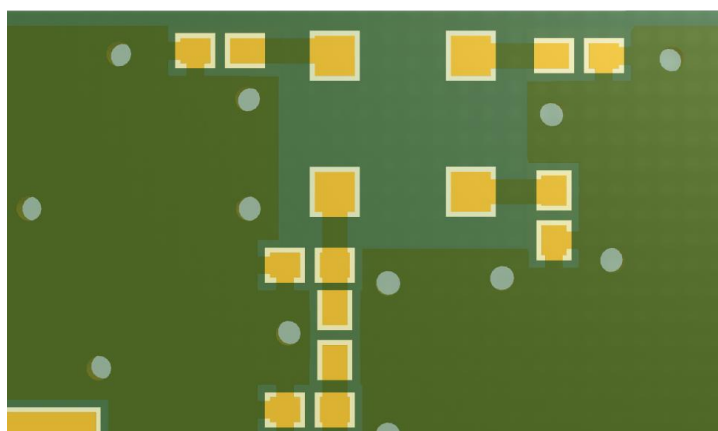



### 11.3 Host PCB Clearance

Below shows the coupler footprint and clearance through all layers on the PCB. Only the coupler pads and connections to feed and GND are present within this clearance area.

Example host layout

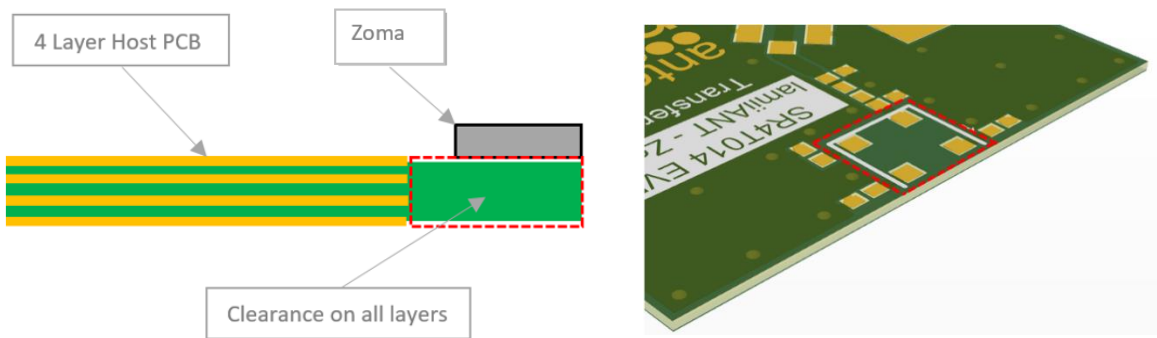

Placement of components and traces adjacent to the coupler should maintain a minimum clearance of 5mm from either side. The GND should flood around the coupler for at least 5mm.

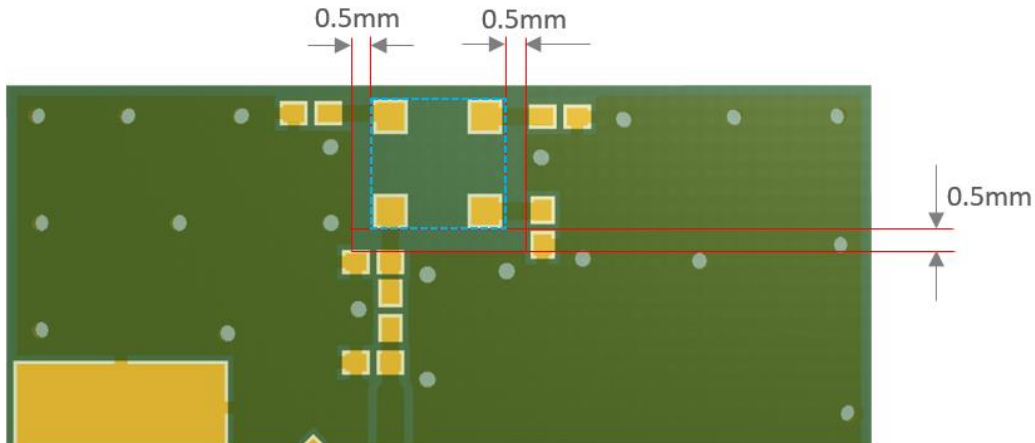

## 12.0 Reference Board

The reference board for SR4T014 has been designed for evaluation purposes, and includes an SMA female connector.

SR4T014 Evaluation board

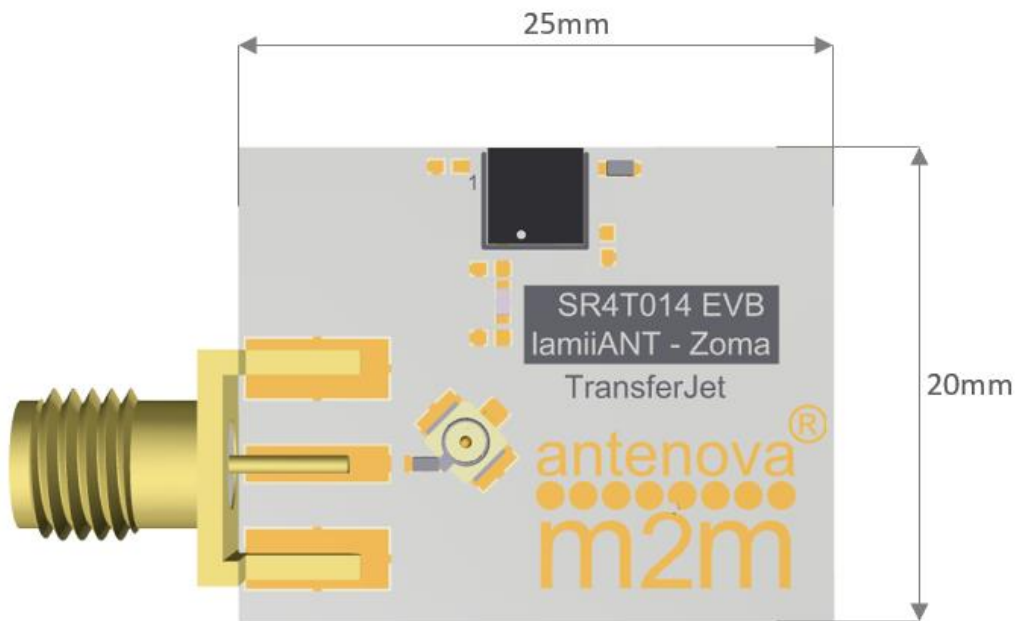

To order a reference board contact [sales@antenna-m2m.com](mailto:sales@antenna-m2m.com)  
Two EVB per kit

### 13.0 Reference Board Matching Circuit

The reference board for SR4T014 has been designed for evaluation purposes, and includes an SMA female connector.

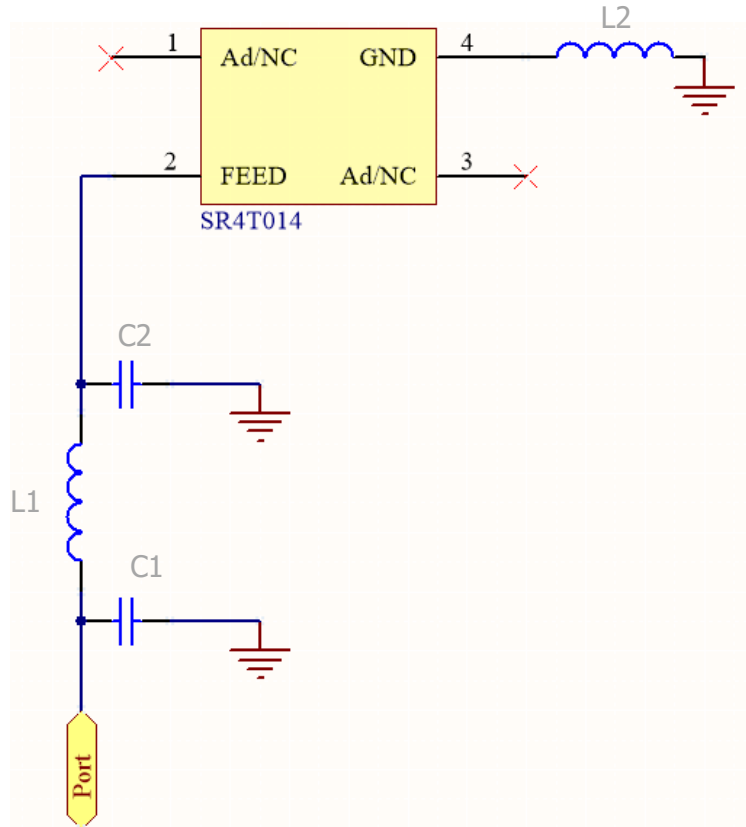

Designator	Type	Value	Description
L1	Inductor	2.2nH	Murata LQG15HN series
C1, C2	Not Fitted	Not Fitted	Not Fitted
L2	Resistor	0R	0R resistor (0402)

## 14. Soldering

This coupler is suitable for lead free soldering. The reflow profile should be adjusted to suit the device, oven and solder paste, while observing the following conditions:

- The maximum temperature should not exceed 240 °C
- However for lead free soldering, a maximum temperature of 255 °C for no more than 20 seconds is permitted.
- The coupler should not be exposed to temperatures exceeding 120 °C more than 3 times during the soldering process.

## 15. Hazardous Material Regulation Conformance

The coupler has been tested to conform to RoHS requirements. A certificate of conformance is available from Antenova M2M's website.

## 16. Packaging

### 16.1 Optimal Storage Conditions

Temperature	-10°C to 40°C
Humidity	Less than 75% RH
Shelf life	24 Months
Storage place	Away from corrosive gas and direct sunlight
Packaging	Couplers should be stored in unopened sealed manufacturer's plastic packaging.

**Note:** Storage of open reels of couplers is not recommended due to possible oxidization of pads on couplers. If short term storage is necessary, then it is highly recommended that the bag containing the coupler reel is re-sealed and stored in like storage conditions as in above table.

The shelf life of the coupler is 2 years provided the factory seal on the package has not been broken.

## 16.2 Tape Characteristics

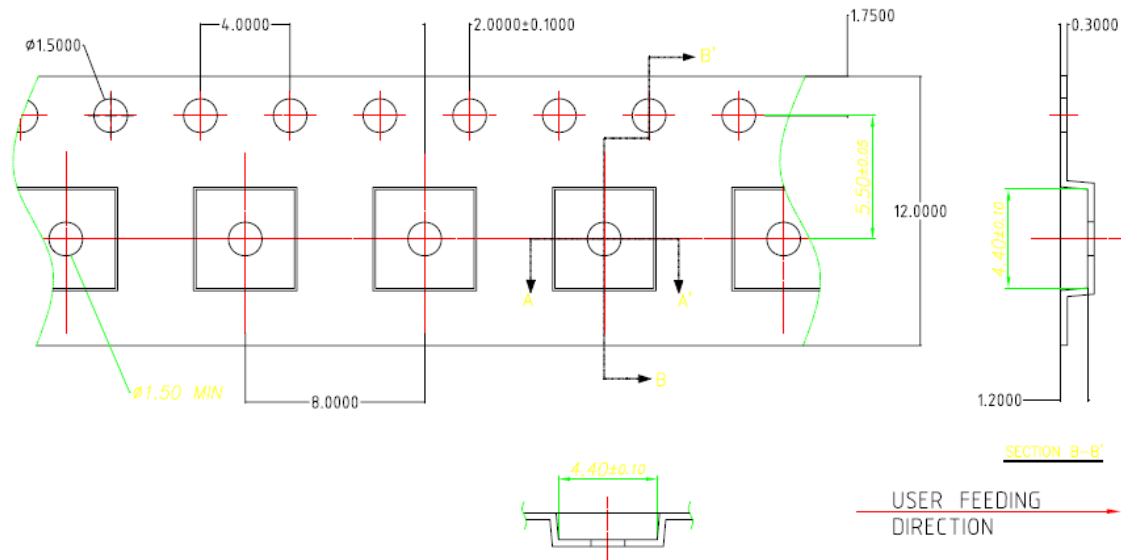

1. Ten sprocket hole pitch cumulative tolerance =  $\pm 0.2\text{mm}$
2. Camber not to exceed 1mm in 100mm

## 16.3 Reel Dimensions

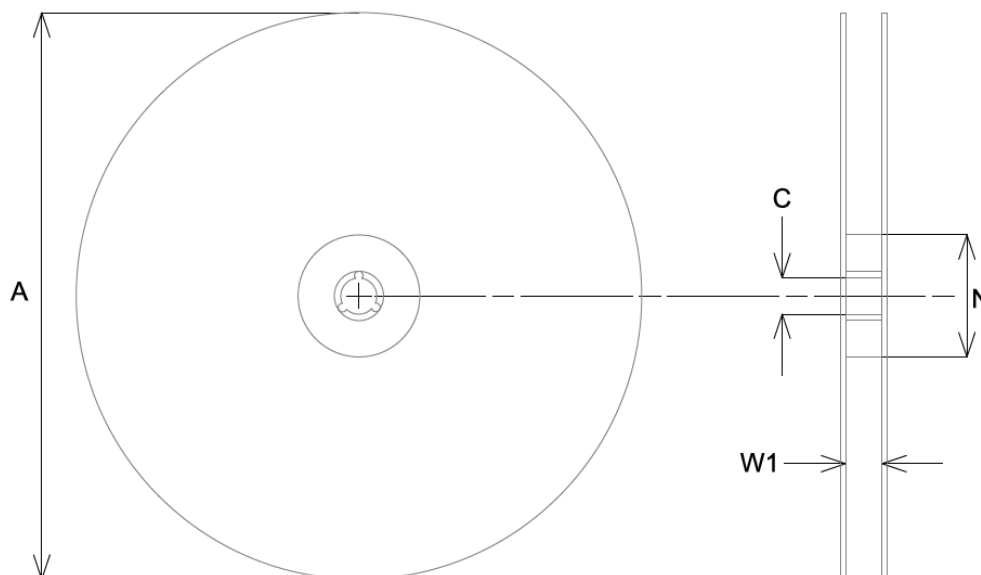

A	C	N	W1
178.0 $\pm$ 2.0	13.2 $\pm$ 0.5	600.0 $\pm$ 0.2	13.0 $\pm$ 0.3

Antennas for Wireless M2M Applications

## 16.4 Box Dimensions

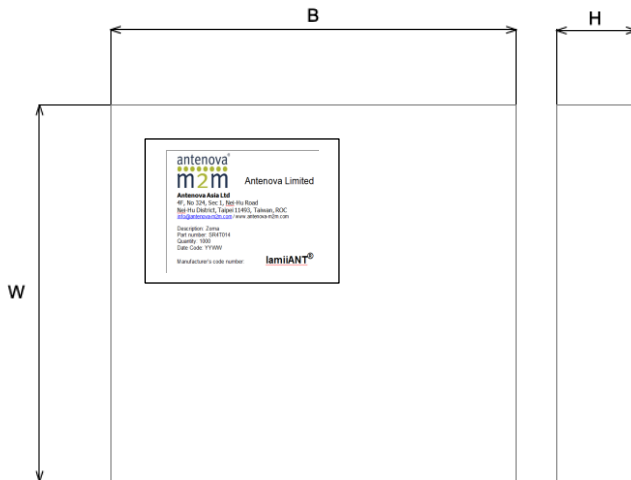

Width (W)	Breadth (B)	Thickness (H)
185mm	205mm	40mm

## 16.5 Bag Properties

Reels are supplied in protective plastic packaging

## 16.6 Label Information

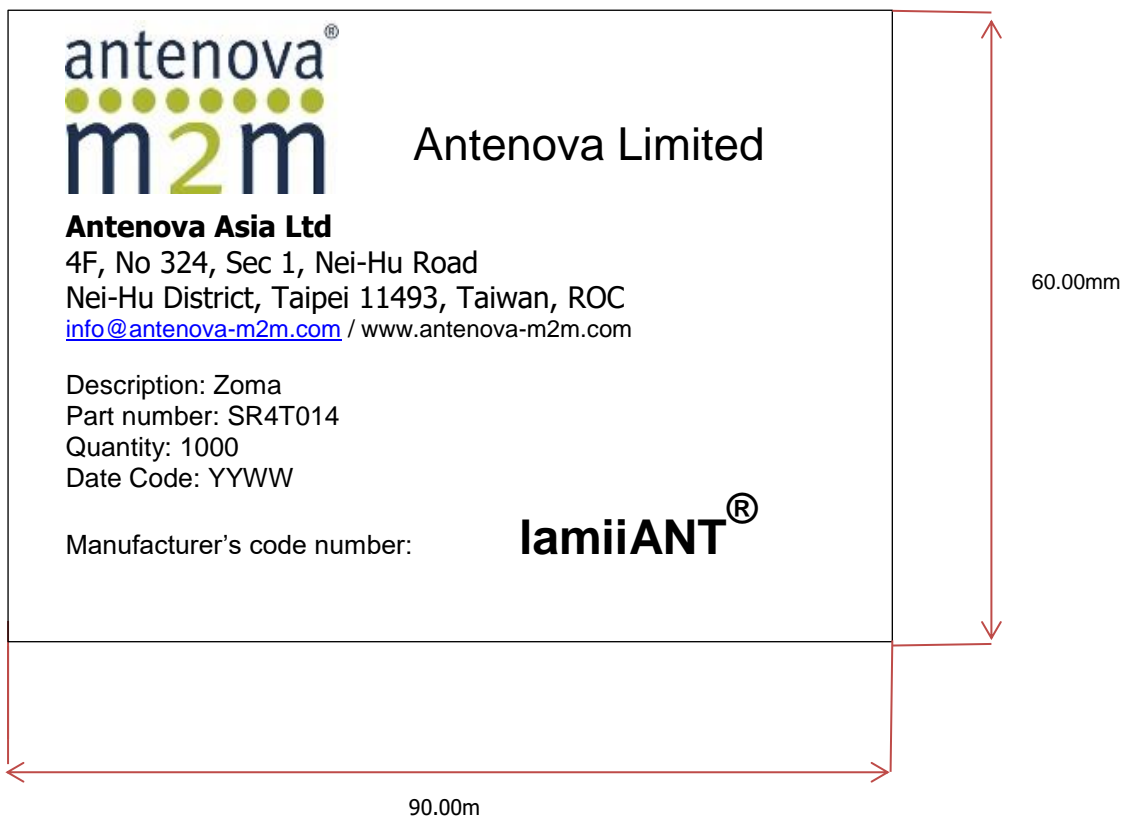

Antennas for Wireless M2M Applications



[www.antenova-m2m.com](http://www.antenova-m2m.com)

**Corporate Headquarters**

Antenova Limited  
2<sup>nd</sup> Floor Titan Court  
3 Bishop Square  
Hatfield  
AL10 9NA  
UK

**Tel:** +44 1223 810600

**Email:** [sales@antenova-m2m.com](mailto:sales@antenova-m2m.com)

**North America Headquarters**

Antenova Limited  
100 Brush Creek Road, Suite 103  
Santa Rosa  
California 95404  
USA

**Tel:** +1 707 890 5202

**Email:** [sales@antenova-m2m.com](mailto:sales@antenova-m2m.com)

**Asia Headquarters**

Antenova Asia Limited  
4F, No. 324, Sec. 1, Nei-Hu Road  
Nei-Hu District  
Taipei 11493  
Taiwan, ROC

**Tel:** +886 (0) 2 8797 8630

**Fax:** +886 (0) 2 8797 6890

**Email:** [sales@antenova-m2m.com](mailto:sales@antenova-m2m.com)

**Copyright© Antenova Ltd.** All Rights Reserved. Antenova®, Antenova M2M®, gigaNOVA® the Antenova product family names and the Antenova M2M logos are trademarks and/or registered trademarks of Antenova Ltd. Any other names and/or trademarks belong to their respective companies.

The materials provided herein are believed to be reliable and correct at the time of printing. Antenova does not warrant the accuracy or completeness of the information, text, graphics or other items contained within this information. Antenova further assumes no responsibility for the use of this information, and all such information shall be entirely at the user's risk.



Certificate No: 4598

Antennas for Wireless M2M Applications

## X-ON Electronics

Largest Supplier of Electrical and Electronic Components

*Click to view similar products for [Antennas](#) category:*

*Click to view products by [Antenova](#) manufacturer:*

Other Similar products are found below :

[GAN30084EU](#) [930-033-R](#) [GW17.07.0250E](#) [1513563-1](#) [EXE902SM](#) [APAMPG-117](#) [MAF94383](#) [W3908B0100](#) [W6102B0100](#) [YE572113-30RSMM](#) [108-00014-50](#) [66089-2406](#) [SPDA17RP918](#) [A09-F8NF-M](#) [A09-F5NF-M](#) [RGFRA1903041A1T](#) [W3525BW100](#) [W3593B0100](#) [W3921B0100](#) [SIMNA-868](#) [SIMNA-915](#) [SIMNA-433](#) [W1044](#) [W1049B090](#) [A75-001](#) [WTL2449CQ1-FRSMM](#) [CPL9C](#) [EXB148BN](#) [0600-00060](#) [TRA9020S3PBN-001](#) [GD5W-28P-NF](#) [MA9-7N](#) [GD53-25](#) [GD5W-21P-NF](#) [EXB144SM](#) [C37](#) [MAF94051](#) [GD35-17P-NF](#) [P1744](#) [MA9-5N](#) [EXD420PL](#) [B1322NR](#) [QWFTB120](#) [MAF94271](#) [MAF94300](#) [GPSMB301](#) [FG4403](#) [AO-AGSM-OM54](#) [5200232](#) [MIKROE-2349](#)