

**高速光耦**  
**High Speed Photo**  
**Coupler**

**AT074L**

**Product Data Sheet**

**AOTE DCC**  
**RELEASE**

**台湾奥特半导体科技有限公司**

TAIWAN AOTE SEMICONDUCTOR TECHNOLOGY CO.,LTD

[www.aotesemi.com](http://www.aotesemi.com)

## 概述 Description

双通道 AT074L 光电耦合器的最低数据传输速率达15Mbit/s，具有卓越的高速性能和超低功耗。AT074L 由 高速 LED 和 CMOS 检测芯片组成。每个检测器都内置集成 型光电二极管、高速跨阻放大器和带有输出驱动电路的电压比较器。AT074L 为光电耦合器 SOP8 封装类型。

The dual-channel AT074L optocoupler has a minimum Data transfer rate of 15 mbit-s and offers superior high-speed performance and ultra-low power consumption. AT074L consists of high-speed LED and CMOS detection chip. Each detector has a built-in integrated, photodiode, high-speed Transimpedance amplifier, and a voltage comparator with an output drive circuit. AT074L is the type of opto-electronic coupler Sop8 package.

## 特性 Features

- . 高速响应 15 MBit/s  
High speed response 15 Mbit/s
- . 工作温度：-40°C~ 105°C  
Operating Temperature: -40 ° C ~ 105 ° C
- . SOP8 封装  
Sop8 package
- . 共模抑制能力至少达 10 kV/μs  
The common mode suppression ability is at least 10 kV/μs
- . 无短时脉冲电源启动功能  
No short-time pulse power start function

## 应用 Applications

- . 数字现场总线隔离  
Digital fieldbus isolation
- . 多路复用数据传输  
Multiplexing data transfer
- . 电脑外设接口  
Computer peripheral interface
- . 微处理器系统接口  
Microprocessor system interface
- . 直流/直流转换器  
DC/DC converter

## 真值表 Truth table

INPUT	OUTPUT
ON	L
OFF	H

## 封装和原理图 Package and Schematic Diagram



SOP8

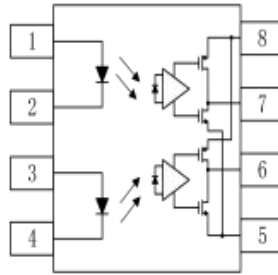

### Pin Configuration

1. Anode 1	8.VCC
2. Cathode 1	7.VO 1
3. Cathode 2	6.VO 2
4. Anode 2	5.GND

注意：在引脚 5 和 8 之间必须连接一个 0.1uF 的旁路电容器。

Note: 0.1uF bypass capacitor must be connected between pins 5 and 8.

## 产品型号命名规则 Order Code

# AT 074L - UN Y - W (V) (ZZ)

①      ②      ③      ④      ⑤      ⑥      ⑦

① 公司代码 Company Code ( AT: 奥特 AOTE )

② 产品系列 Product Series ( 074L )

③ 框架类型 Lead Frame ( Cu: 铜框架 Copper )



④ 树脂类型 Epoxy Type ( H: 无卤 Halogen-free )

⑤ 封装形式 Package( S: SOP)

⑥ 器件工作温度范围 Device Operating Temperature Range ( 特殊范围需填或者空白 Special Range need to be filled in or left blank )

⑦ 内部补充代码 Internal Supplementary Code ( 数字或者空白 Number or None )

## 印字信息 Marking Information

- 印字中 “” 为奥特品牌 LOGO  
“” denotes LOGO
- 印字中 “Y” 代表年份：A(2018), B(2019), C(2020) ... ...  
“Y” denotes YEAR：A(2018), B(2019), C(2020) ... ...
- 印字中 “WW” 代表周号  
“WW” denotes Week’ s number
- 印字中 “N” 代表星期几  
“N” denotes day of the week
- 印字中的 “H” 代表无卤  
“H” denotes Halogen-free

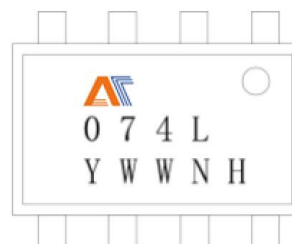

## 极限参数 Absolute Maximum Ratings ( $T_A = 25^\circ\text{C}$ )

应力超过绝对最大额定值可能会损坏设备，建议器件不要在推荐的工作条件之外工作，这可能会影响器件的功能。另外，长期在超出推荐工作条件下工作，可能影响器件的可靠性。最大额定值仅说明应力等级。

Stress exceeding the absolute maximum rating may damage the device, and it is recommended that the device not work outside the recommended operating conditions, which may affect the function of the device. In addition, long-term work in excess of the recommended operating conditions may affect the reliability of the device. The maximum rating indicates only the stress level.

参数 Parameter		符号 Symbol	最小值 Min	最大值 Max	单位 Unit
输入 Input	正向输入电流 Forward Input Current	$I_F$	-	20	mA
	功耗 Power consumption	$P_D$	-	35	mW
输出 Output	电源电压 Supply Voltage	$V_{DD}$	0	6	V
	输出电流 Output Current	$I_O$	-	10	mA
	输出电压 Output Voltage	$V_O$	-0.5	$V_{DD} + 0.5$	V
	功耗 Power consumption	$P_D$	-	100	mW
隔离电压 Isolation Voltage		$V_{ISO}$	-	3750	Vrms
工作温度 Operating Temperature		$T_{opr}$	-40	105	$^\circ\text{C}$
存储温度 Storage Temperature		$T_{stg}$	-55	125	$^\circ\text{C}$
焊接温度 Soldering Temperature		$T_{sol}$	-	260	$^\circ\text{C}$

## 推荐操作条件 Recommended Operating Conditions

推荐的工作条件表规定了实际器件工作的条件，其可保证获得数据表给出的最佳性能。建议器件不要按最大额定值或超过这个值设计工作条件。

The recommended working conditions table specifies the conditions under which the actual device works, ensuring the best performance given by the data table. It is not recommended that devices be designed to work at or above a maximum rating.

参数 Parameter	符号 Symbol	最小值 Min	最大值 Max	单位 Unit
输入电流(ON) Input Current (ON)	$I_F$	12	18	mA
电源电压 Power Supply Voltage	$V_{DD}$	4.5	5.5	V
		3	3.6	V
工作温度 Operating Temperature	$T_A$	-40	+105	$^\circ\text{C}$
电压转化速率 Supply Voltage Slew Rate	$S_R$	0.5	500	V/ms

**产品特性参数 Electro-optical Characteristics (T<sub>A</sub> = 25°C)**

除非另有说明，在推荐的工作条件下测试最小值和最大值。典型值在 T<sub>A</sub> = 25°C, V<sub>DD</sub> = 30V, V<sub>SS</sub> = GND 下测量。All minimum and maximum specifications are at recommended operating conditions, unless otherwise noted. All typical values are at T<sub>A</sub> = 25°C, V<sub>DD</sub> = 30 V, and V<sub>SS</sub> = GND.

参数 Parameter		符号 Symbol	条件 Condition	最小 Min.	典型 Typ.	最大 Max	单位 Unit
发射端 Input	正向电压 Forward Voltage	V <sub>F</sub>	I <sub>F</sub> = 14mA	1.3	1.5	1.8	V
	反向击穿电压 Reverse Breakdown Voltage	B <sub>VR</sub>	I <sub>R</sub> = 10μA	5	-	-	V
接收端 Output	高电平输出电压 High Level Output Voltage	V <sub>OH</sub>	I <sub>F</sub> = 0, I <sub>O</sub> = -4 mA, V <sub>DD</sub> = 5V	V <sub>DD</sub> - 1	V <sub>DD</sub> - 0.2	-	V
			I <sub>F</sub> = 0, I <sub>O</sub> = -4 mA, V <sub>DD</sub> = 3.3V	V <sub>DD</sub> - 1	V <sub>DD</sub> - 0.3	-	V
	低电平输出电压 Low Level Output Voltage	V <sub>OL</sub>	I <sub>F</sub> = 14mA, I <sub>O</sub> = 4mA, V <sub>DD</sub> = 5V	-	0.2	0.8	V
			I <sub>F</sub> = 14mA, I <sub>O</sub> = 4mA, V <sub>DD</sub> = 3.3V	-	0.35	0.8	V
	输入阈值电流 Input Threshold Current	I <sub>TH</sub>	I <sub>OL</sub> = 20 μA	-	8.8	10	mA
	高电平电源电流 High Output Supply Current	I <sub>DDH</sub>	I <sub>F</sub> = 0mA	-	7.6	12	mA
	低电平电源电流 Low Output Supply Current	I <sub>DDL</sub>	I <sub>F</sub> = 14 mA	-	8.3	12	mA
	逻辑高电平传播延迟 Propagation Delay Time to Logic High Output Level	T <sub>PLH</sub>	I <sub>F</sub> = 14mA, C <sub>L</sub> = 15 pF V <sub>DD</sub> = 3.3V	-	22	40	ns
			I <sub>F</sub> = 14mA, C <sub>L</sub> = 15 pF V <sub>DD</sub> = 5V	-	-	50	ns
	逻辑低电平传播延迟 Propagation Delay Time to Logic Low Output Level	T <sub>PHL</sub>	I <sub>F</sub> = 14mA, C <sub>L</sub> = 15 pF, V <sub>DD</sub> = 3.3V	-	28	40	ns
I <sub>F</sub> = 14mA, C <sub>L</sub> = 15 pF, V <sub>DD</sub> = 5V			-	-	50	ns	
脉冲宽度 Pulse Width	T <sub>pw</sub>		66.7			ns	
传输特性 Transport characteristics	脉宽失真 Pulse Width Distortion	T <sub>PLH</sub> - T <sub>PHL</sub>	I <sub>F</sub> = 14mA, C <sub>L</sub> = 15 pF, V <sub>DD</sub> = 3.3V	0	7	25	ns
			I <sub>F</sub> = 14mA, C <sub>L</sub> = 15 pF, V <sub>DD</sub> = 5V			30	ns
	上升时间 (10%-90%) Rise Time (10%-90%)	T <sub>r</sub>	I <sub>F</sub> = 14mA, C <sub>L</sub> = 15 pF	-	20	-	ns
	下降时间 (90%-10%) Fall Time (90%-10%)	T <sub>f</sub>	I <sub>F</sub> = 14mA, C <sub>L</sub> = 15 pF	-	25	-	ns
	传输延迟差  T <sub>PLH</sub> - T <sub>PHL</sub>   Propagation Delay Skew  T <sub>PLH</sub> - T <sub>PHL</sub>	T <sub>PSK</sub>	I <sub>F</sub> = 14mA, C <sub>L</sub> = 15 pF	-	-	30	ns
	输出高电平共模抑制 Logic High Common Mode Transient Immunity	C <sub>MH</sub>	I <sub>F</sub> = 0mA T <sub>A</sub> = 25°C,  V <sub>CM</sub>   = 1kV	10	15		kV/us

输出低电平共模抑制 Logic Low Common Mode Transient Immunity	$ CM_L $	$I_F=14mA$ $T_A=25^{\circ}C$ , $ V_{CM} =1kV$	10	15		kV/us
隔离电阻 Isolation resistance	$R_{I-O}$	$V_H=500V$ , 40 ~60%R.H.	-	1012	-	$\Omega$
隔离电容 Isolation Capacitance	$C_{I-O}$	$V=0, f=1MHz$	-	0.6	-	pF

注意：指任意二个器件，在相同的测试条件下，tPHL 与tPLH 之间的差。

**典型光电特性曲线 Typical Electro-Optical Characteristics Curves**

Fig.1 Forward current vs. Forward Voltage

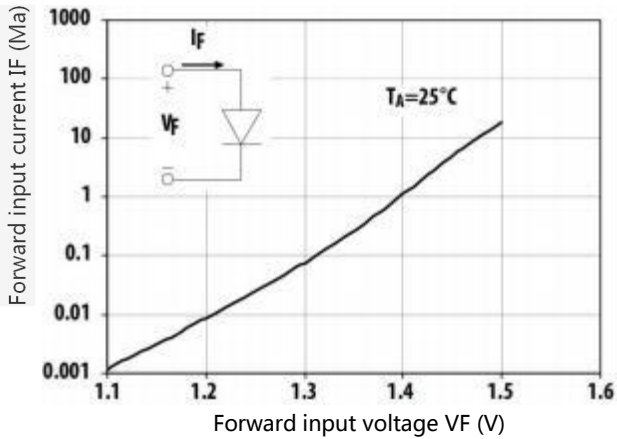

Fig.2 Input threshold current vs. Ambient temperature

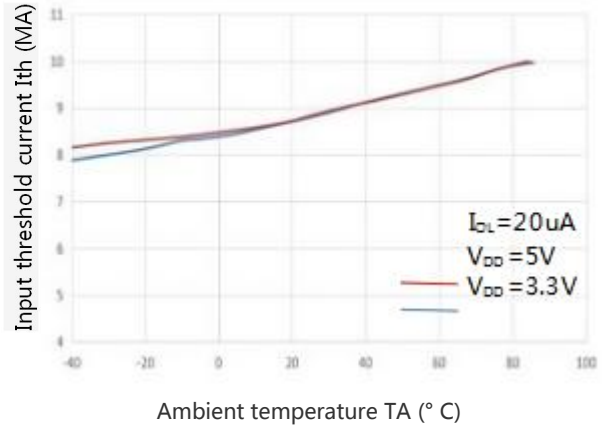

Fig.3 High output supply current vs. Ambient temperature

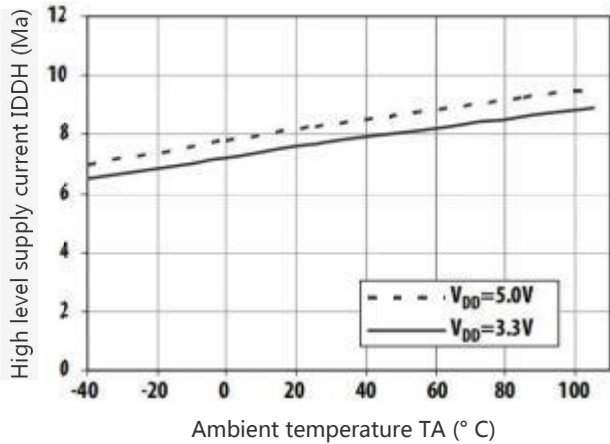

Fig.4 Low output supply current vs. Ambient temperature

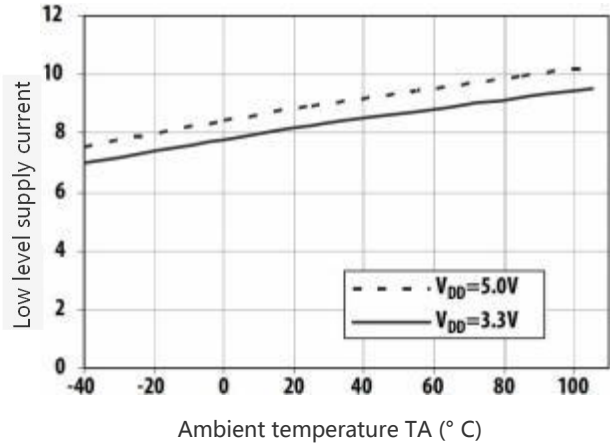

Fig.5 Propagation delay vs. Pulse input current

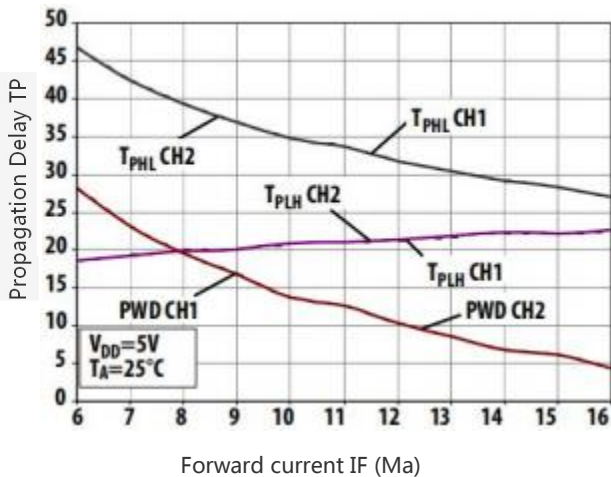

Fig.6 Propagation delay vs. Pulse input current

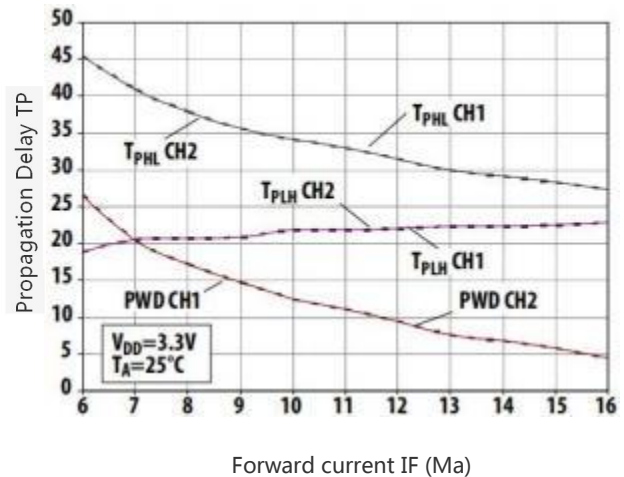

Fig.7 Forward voltage vs. Ambient temperature

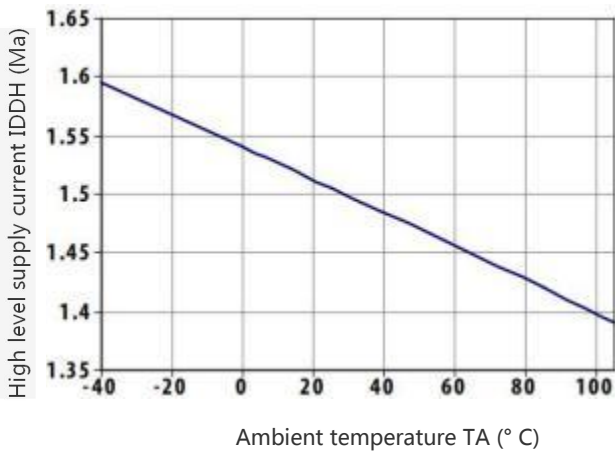

Fig.8 Propagation delay vs. Ambient temperature

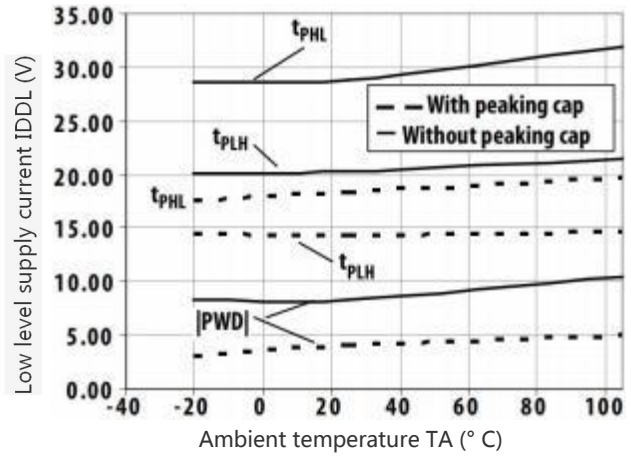
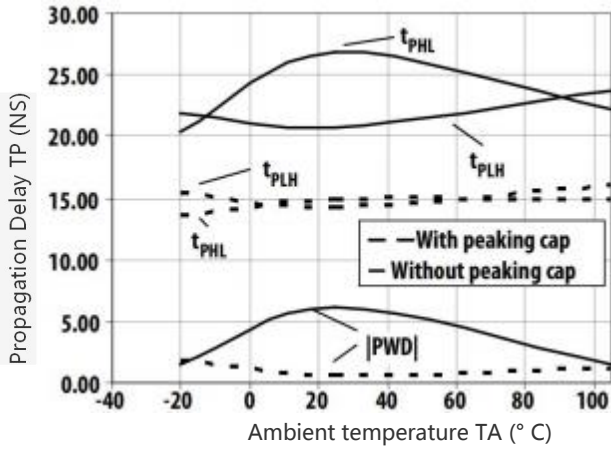

Fig.9 Propagation delay vs. Ambient temperature





**CMR 测试电路 Test Circuit for Common Mode Transient Immunity**

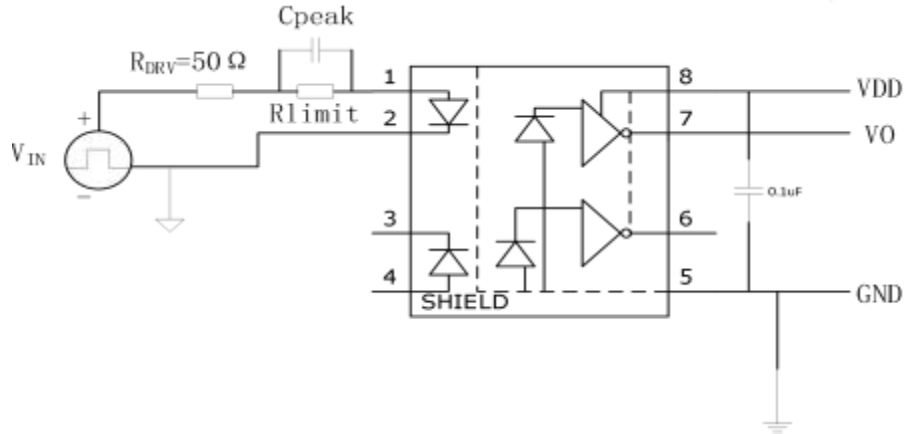
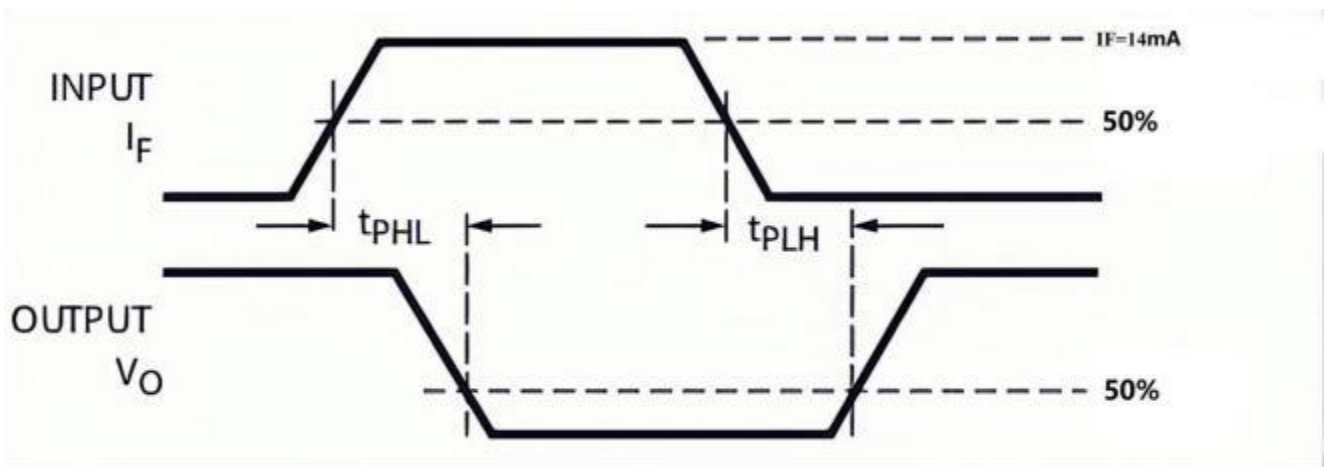
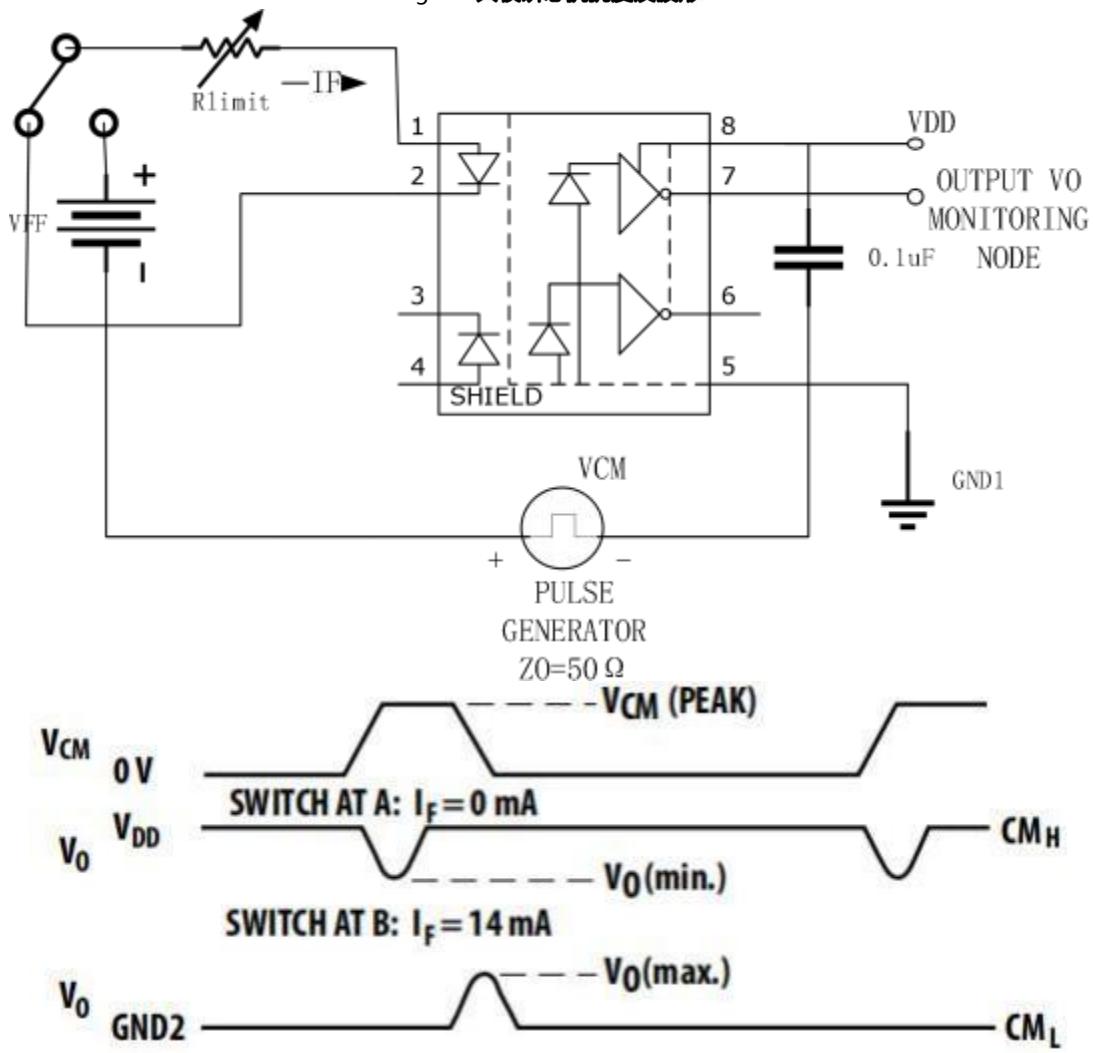

Fig.10 VDD=3.3V / 5V, Cpeak=100pF, Rlimit=80Ω / 210Ω



TPHL and TPLH 测试波形

Fig.11 共模瞬态抗扰度及波形



### 外形尺寸 Outline Dimensions

SOP8

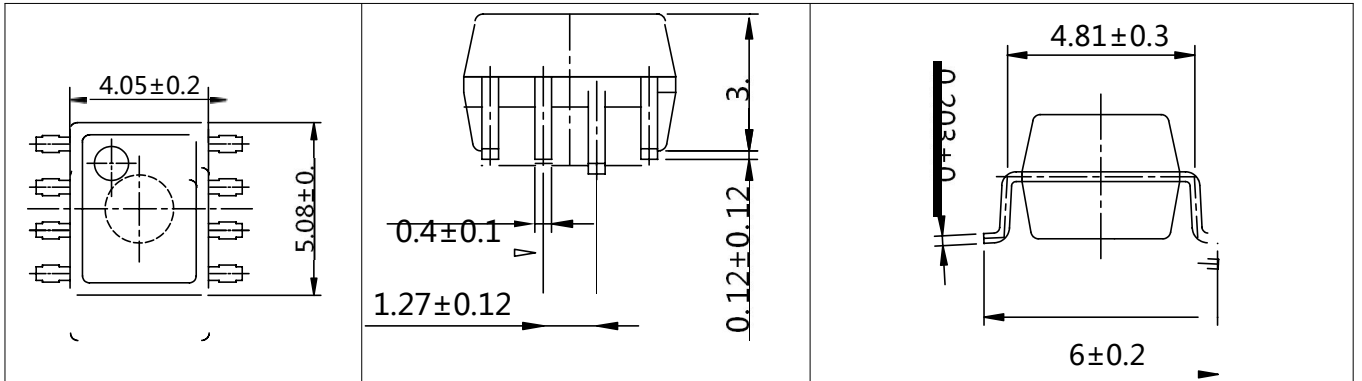

单位 Unit: mm

### 建议焊盘布局 Recommended Pad Layout

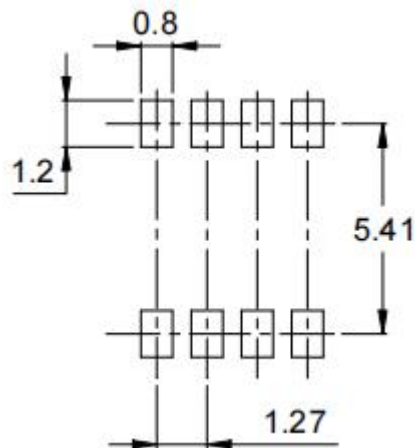

单位 Unit: mm

## 包装 Packing

### ■ 汇总表 Summary table

封装形式	包装方式	盘数量	盒数量	箱数量	静电袋规格	盒规格	箱(双瓦楞)规格	备注
SOP8	卷盘 ( $\phi$ 330mm 蓝盘)	2k/盘	2 盘/盒	10 盒/箱	430*400*0.075mm	340*60*340mm	620*360*365mm	首尾端空至少 200mm
Package Type	Packing Form	Quantity per Reel	Quantity per Box	Quantity per Carton	Antistatic Bag Specification	Box Specification	Carton Specification	Note
SOP8	Reel ( $\phi$ 330mm Blue)	2k pcs/reel	2 reels/box	10 boxes/ctn	430*400*0.075mm	340*60*340mm	620*360*365mm	Leave at least 200mm of blank space at both ends

### ■ 编带包装 Tape & Reel

- 1) 每卷数量：2000 只  
Qty/reel : 2000 pcs.
- 2) 每箱数量：40000 只。  
Qty/ctn : 40000 pcs.
- 3) 内包装：每盒 2 盘。  
Inner packing : 2 reels/box.
- 4) 示意图 Schematic :

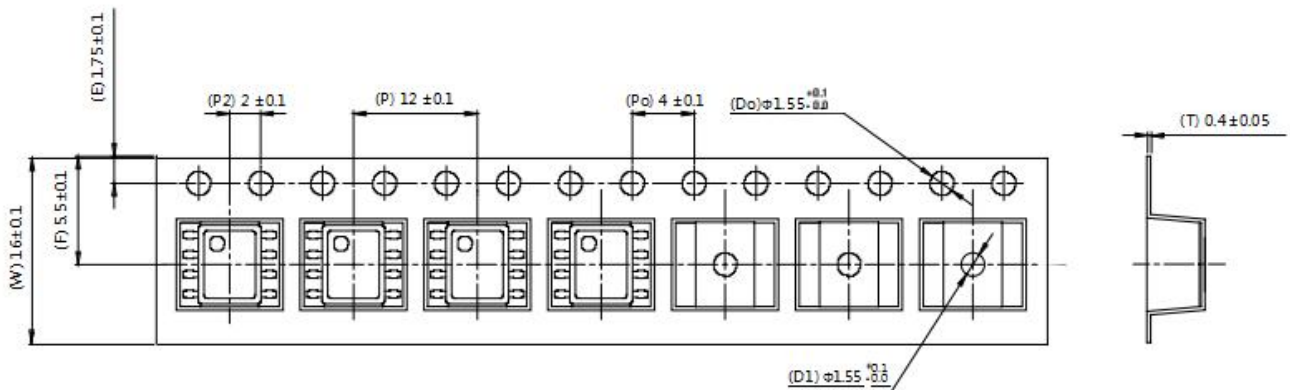

单位 Unit : mm

## 注意 Attention

- 奥特持续不断改进质量、可靠性、功能或设计，保留此文件更改的权利恕不另行通知。  
AOTE continuously improve quality, reliability, function or design. We reserve the right to change this document without notice.
- 请遵守产品规格书使用，奥特不对使用时不符合产品规格书条件而导致的质量问题负责。  
Please use in accordance with the product specification. AOTE is not responsible for the quality problems caused by non-compliance with the product specifications.
- 对于需要高可靠性或安全性的设备/装置需求，请联系我们的销售人员。  
For equipment/devices where high reliability or safety is required, please contact our sales representatives.
- 当需要用于任何“特定”应用时，请咨询我们的销售人员。  
When requiring a device for any “specific” application, please contact our sales in advice.
- 如对文件中表述的内容有疑问，欢迎联系我们。  
If you have any questions about the contents of the document, please contact us.

## X-ON Electronics

Largest Supplier of Electrical and Electronic Components

*Click to view similar products for [AOTE manufacturer](#):*

Other Similar products are found below :

[6N137S](#) [AT815-CuH-D](#) [AT851-CuH-D](#) [AT852-CuH-D](#) [ATH11L3-CuH-D](#) [ATH11L1-CuH-S](#) [ATH11L3-CuH-S](#) [AT4N32-CuH-D](#) [AT4N33-CuH-S](#) [AT452-CuH-S](#) [AT4N26-CUH-D](#) [AT480-CuH-W](#) [ATH11L2-CuH-S](#) [AT226-CuH-S](#) [AT223-CuH-S](#) [AT4N31-CuH-S](#) [AT4N36-CuH-S](#) [AT4N30-CuH-S](#) [AT4N32-CuH-S](#) [AT4N38-CuH-S](#) [AT4N26-CUH-S](#) [AT4N27-CuH-S](#) [AT4N29-CuH-S](#) [AT4N28-CUH-S](#) [AT4N37-CuH-S](#) [AT074L-CuH-S](#) [AT4506-CuH-S](#) [AT223-CuH-D](#) [AT226-CuH-D](#) [AT222-CuH-D](#) [AT4506-CuH-D](#) [AT4N30-CuH-D](#) [AT4N29-CuH-D](#) [AT4N38-CuH-D](#) [AT4N36-CuH-D](#) [AT4N33-CuH-D](#) [AT4N28-CUH-D](#) [AT4N37-CuH-D](#) [AT4N27-CuH-D](#) [AT4N31-CuH-D](#) [MOC3063M](#) [AT212-CuH-D](#) [AT816D-FEH-S](#) [MOC3083SM](#) [AT222-CuH-S](#) [AT0531-CuH-S](#) [AT0530-CuH-S](#) [MOC3052SM](#) [MOC3051SM](#) [ATV252-CuH-S](#)