



智能功率模块接口光耦
Intelligent Power Module

AT4506

Product Data Sheet

AOTE DCC
RELEASE

台湾奥特半导体科技有限公司

TAIWAN AOTE SEMICONDUCTOR TECHNOLOGY CO.,LTD

www.aotesemi.com

概述 Description

AT4506 包含一个 GaAsP LED，它被光学耦合到一个集成的高增益光电探测器。芯片上的 20KΩ 输出上拉电阻可以通过短接输出引脚 6 和 7 来启用，因此在常见的 IPM 应用中不需要外部上拉电阻。

The AT4506 contain a GaAsP LED, it is optically coupled to an integrated high gain photo detector. An on chip 20 KΩ output pull-up resistor can be enabled by shorting output pins 6 and 7, thus eliminating the need for an external pull-up resistor in common IPM applications.

特性 Features

- 用于TTL和IPM应用的短传播延迟
Short propagation delays for TTL and IPM applications
- 在工业温度范围内为普通IPM应用指定的性能：-40°C 至100°C
Performance specified for common IPM applications over industrial temperature range: -40°C to 100°C
- 快速传播延迟最大值： $t_{PHL} = 480 \text{ ns}$, $t_{PLH} = 550 \text{ ns}$
Fast maximum propagation delays: $t_{PHL} = 480 \text{ ns}$, $t_{PLH} = 550 \text{ ns}$
- 最小脉冲宽度失真 PWD = 450 ns
Minimized Pulse Width Distortion: PWD = 450 ns
- 15 KV/μs 最小共模瞬态不稳定性。(VCM = 1500 V)
15 KV/μs minimum common mode transient immunity. (VCM = 1500 V)

应用 Applications

- IPM 隔离
IPM isolation
- 隔离 IGBT/MOSFET 门驱动器
Isolated IGBT/MOSFET gate drive
- 交流和直流无刷直流电机驱动器
AC and brushless DC motor drives
- 工业逆变器
Industrial inverters
- IF = 10 mA 时 CTR > 44%
CTR > 44% at IF = 10 mA

真值表 Truth table

LED	VO
OFF	L
ON	H

封装和原理图 Package and Schematic Diagram

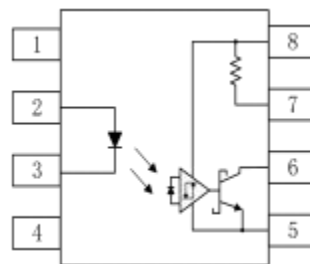

Pin Configuration

1. NC
2. Anode
3. Cathode
4. NC
5. GND
6. O
7. VL
8. VCC

注：建议在引脚 5 和 8 之间连接一个 0.1μF 的旁路电容器。



Note: The connection of a 0.1 μF bypass capacitor between pins 5 and 8 is recommended.

产品型号命名规则 Order Code
AT 4506 - UN Y - W (V) (ZZ)

① ② ③ ④ ⑤ ⑥ ⑦

- ① 公司代码 Company Code (AT: 奥特 Aote)
- ② 产品系列 Product Series (4506)
- ③ 框架类型 Lead Frame (Cu: 铜框架 Copper)
- ④ 树脂类型 Epoxy Type (H: 无卤 Halogen-free)
- ⑤ 封装形式 Package (D: DIP , S:SMD)
- ⑥ 器件工作温度范围 Device Operating Temperature Range (特殊范围需填或者空白 Special Range need to be filled in or left blank)
- ⑦ 内部补充代码 Internal Supplementary Code (数字或者空白 Number or None)

印字信息 Marking Information

- 印字中 “” 为奥特品牌 LOGO
“” denotes LOGO
- 印字中 “Y” 代表年份 ; A(2018),B(2019),C(2020)
“Y” denotes YEAR : A(2018), B(2019), C(2020)
- 印字中 “WW” 代表周号
“WW” denotes week' s number
- 印字中 “N” 代表星期几
“N” denotes day of the week
- 印字中的 “H” 代表无卤
“H” denotes Halogen-free

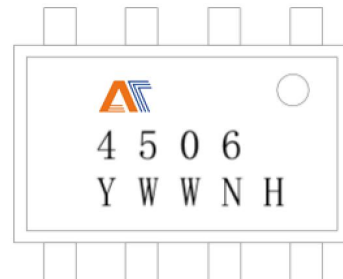

绝缘和安规信息 Insulation and Safety related specifications

项目 Item	符号 Symbol	数值 Value	单位 Unit	备注 Remark
爬电距离 Creepage Distance	L	>7.0	mm	从输入端到输出端，沿本体最短距离路径 Measured from input terminals to output terminals, shortest distance path along body
电气间隙 Clearance Distance	L	>7.0	mm	从输入端到输出端，通过空气的最短距离 Measured from input terminals to output terminals, shortest distance through air
绝缘距离 Insulation Thickness	DTI	> 0.4	mm	发射器和探测器之间的绝缘厚度 Insulation thickness between emitter and detector
峰值隔离电压 Peak Isolation Voltage	V_{IORM}	1500	V_{peak}	DIN/EN/DIN EN60747-5-5
瞬态隔离电压 Transient isolation voltage	V_{IOTM}	7000	V_{peak}	DIN/EN/DIN EN60747-5-5
隔离电压 Isolation Voltage	V_{iso}	>5000	V_{rms}	For 1 min

极限参数 Absolute Maximum Ratings ($T_a = 25^\circ\text{C}$)

参数 Parameter	符号 Symbol	额定值 Rating	单位 Unit
发射端 Input	平均输入电流 Average Forward Input Current	$I_{F(AVG)}$	25 mA
	峰值正向输入电流 Peak Forward Input Current (50% duty cycle, ≤ 1 ms pulse width)	$I_{F(PEAK)}$	25 mA
	峰值瞬态输入电流 Peak Transient Input Current (≤ 1 μs pulse width, 300 pps)	$I_{F(TRANS)}$	50 mA
	反向电压 Reverse Input Voltage	V_R	5 V
接收端 output	平均输出电流 Average Output Current	$I_{O(AVG)}$	15 mA
	电阻器电压 Resistor Voltage	V_7	-0.5 ~ V_{CC} V
	电源电压 Supply Voltage	V_{CC}	-0.5 ~ 30 V
	输出电压 Output Voltage	V_O	-0.5 ~ 30 V
	输出功耗 Output Power Dissipation[3]	P_O	100 mW
总功耗 Total Power Dissipation	P_t	145 mW	
隔离电压 Isolation voltage	V_{iso}	5000 V_{rms}	
工作温度 Operating Temperature	T_{opr}	-40 ~ +100 $^\circ\text{C}$	
存储温度 Storage Temperature	T_{stg}	-55 ~ +125 $^\circ\text{C}$	

推荐操作条件 Recommended Operating Conditions

参数 Parameter	符号 Symbol	最小值 Min.	最大值 Max.	单位 Unit
电源电压 Supply Voltages	V_{DD}	4.5	30	V
输出电压 Output Voltage	V_O	0	30	V
开启电流 Forward Input Current (ON)	$I_{F(ON)}$	10	20	mA
关断电压 Forward Input Voltage (OFF)	$V_{F(OFF)}$	-5	0.8	V
操作温度 Operating Temperature	T_A	-40	100	°C

产品特性参数 Electro-optical Characteristics ($T_a = 25^\circ\text{C}$)

参数 Parameter	符号 Symbol	条件 Condition	最小 Min.	典型 Typ.	最大 Max.	单位 Unit
电流传输比 Current Transfer Ratio	CTR	$I_f = 10\text{ mA}$ $V_o = 0.6\text{ V}$	44	90	-	%
低电平输出电流 Low Level Output Current	I_{OL}	$I_f = 10\text{ mA}$ $V_o = 0.6\text{ V}$	4.4	9.0	-	mA
低电平输出电压 Low Level Output Voltage	V_{OL}	$I_o = 2.4\text{ mA}$	-	0.17	0.6	V
输入阈值电流 Input Threshold Current	I_{IH}	$V_o = 0.8\text{ V}$ $I_o = 0.75\text{ mA}$	-	0.96	5	mA
高电平输出电流 High Level Output Current	I_{OH}	$V_f = 0.8\text{ V}$	-	3	50	μA
高电平电源电流 High Level Supply Current	I_{CH}	$V_f = 0.8\text{ V}$ $V_o = \text{Open}$	-	0.7	1.3	mA
低电平电源电流 Low Level Supply Current	I_{CL}	$I_f = 10\text{ mA}$ $V_o = \text{Open}$	-	0.7	1.3	mA
输入正向电压 Input Forward Voltage	V_f	$I_f = 10\text{ mA}$	-	1.32	1.8	V
正向电压的温度系数 Temperature Coefficient of Forward Voltage	$\Delta V_f / \Delta T_A$	$I_f = 10\text{ mA}$	-	-	-1.6	mV/°C
输入反向击穿电压 Input Reverse Breakdown Voltage	B_{VR}	$I_r = 10\text{ }\mu\text{A}$	5	-	-	V
输入电容 Input Capacitance	C_{IN}	$f = 1\text{ MHz}$ $V_f = 0\text{ V}$	-	60	-	pF
内置上拉电阻 Internal Pull-up Resistor	R_L	$T_A = 25^\circ\text{C}$	14	20	25	k Ω
内置上拉电阻温度系数 Internal Pull-up Resistor Temperature Coefficient	$\Delta R_L / \Delta T_A$	-	-	0.014	-	k Ω /°C
输入输出电阻 Input-Output Resistance	R_{I-O}	$V_{I-O} = 500\text{ Vdc}$	-	10^{12}	-	Ω
电容 (输入-输出) Capacitance (Input-Output)	C_{I-O}	$f = 1\text{ MHz}$	-	0.6	-	pF

开关特性 Switching Specification(Ta =25°C, RL =20KΩ External)

超过推荐的操作条件，除非另有规定：

Over recommended operating conditions unless otherwise specified:

TA = -40°C to +100°C, VCC = +4.5 V to 30 V, IF(on) = 10 mA to 20 mA, VF(off) = -5 V to 0.8 V

参数 Parameter	符号 Symbol	条件 Condition	最小 Min.	典型 Typ.	最大 Max.	单位 Unit
逻辑低电平传输延迟 Propagation Delay Time to Logic Low at Output	t _{PHL}	IF(on) = 10 mA, VF(off) = 0.8 V, VCC = 15.0 V, CL = 100 pF, VTHLH = 2.0 V, VTHHL = 1.5 V	30	250	400	ns
逻辑高电平传输延迟 Propagation Delay Time to High Output Level	t _{PLH}		270	400	550	
脉宽失真 Pulse Width Distortion	PWD	CL = 100 pF	-	150	450	
传输延迟差 Propagation Delay Difference Between Any 2 Parts	t _{PLH} -t _{PHL}	-	-150	150	450	
输出高电平共模抑制 Output High Level Common Mode Transient Immunity	CM _H	VCM =1000V IF=0mA	15	30	-	kV/μs
输出低电平共模抑制 Output Low Level Common Mode Transient Immunity	CM _L	VCM =1000V IF=6.0mA	15	30	-	

开关特性 Switching Specification(Ta =25°C, RL =Internal Pull-up)

参数 Parameter	符号 Symbol	条件 Condition	最小 Min.	典型 Typ.	最大 Max.	单位 Unit
逻辑低电平传输延迟 Propagation Delay Time to Logic Low at Output	t _{PHL}	IF(on) = 10 mA, VF(off) = 0.8 V, VCC = 15.0 V, CL = 100 pF, VTHLH = 2.0 V, VTHHL = 1.5 V	20	300	400	ns
逻辑高电平传输延迟 Propagation Delay Time to High Output Level	t _{PLH}		220	400	650	
脉宽失真 Pulse Width Distortion	PWD		-	100	500	
传输延迟差 Propagation Delay Difference Between Any 2 Parts	t _{PLH} -t _{PHL}		-150	100	500	
输出高电平共模抑制 Output High Level Common Mode Transient Immunity	CM _H	VCM =1000V IF=0mA	-	30	-	kV/μs
输出低电平共模抑制 Output Low Level Common Mode Transient Immunity	CM _L	VCM =1000V IF=6.0mA	-	30	-	
电源抑制比 Power Supply Rejection	PSR	Square Wave, t _{RISE} , t _{FALL} > 5 ns, no bypass capacitors	-	1.0	-	Vp-p

典型光电特性曲线 Typical Electro-Optical Characteristics Curves

Fig.1 Output Current vs. Forward Voltage

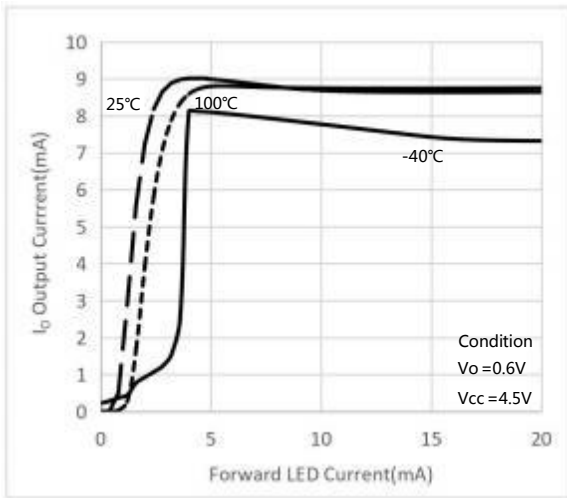

Fig.2 Normalized output current vs. temperature

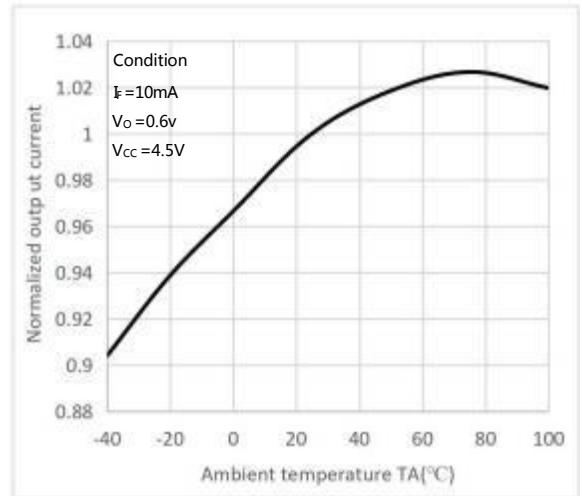

Fig.3 High level output current vs. Ambient temperature

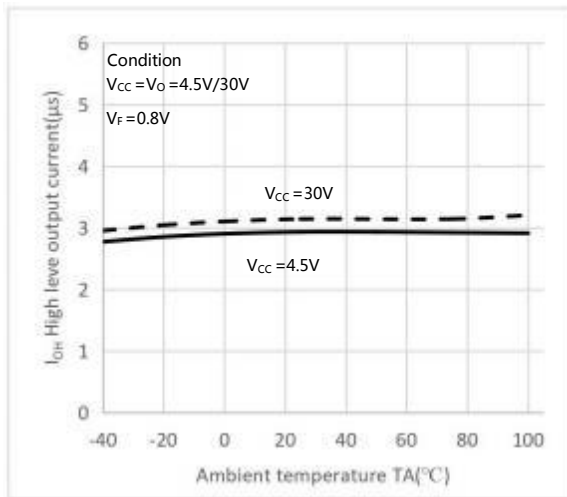

Fig.4 Input current vs. Forward Voltage

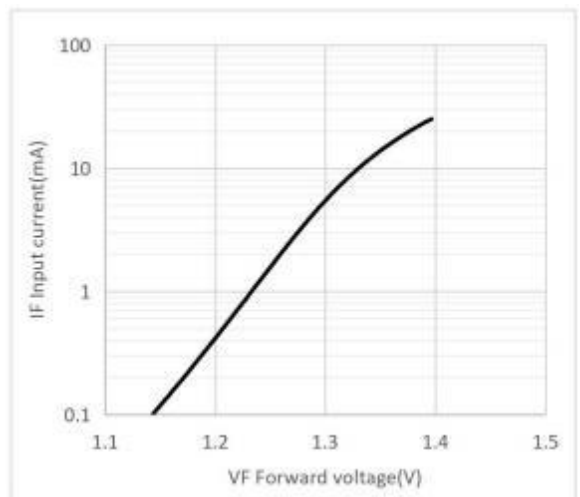

Fig.5 Propagation delay with external 20 kΩ RL vs. temperatur

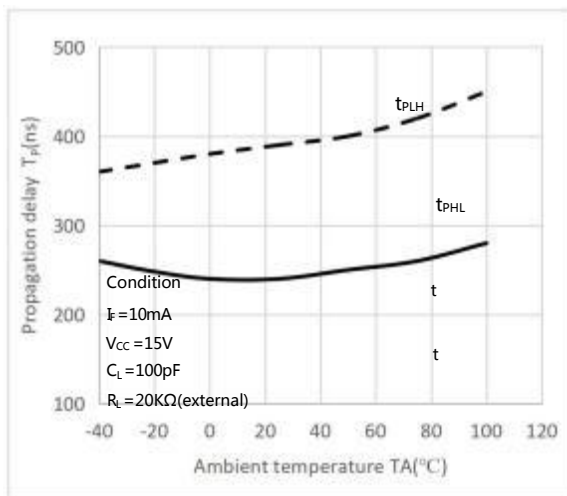

Fig.6 Propagation delay with internal 20 kΩ RL vs. temperature

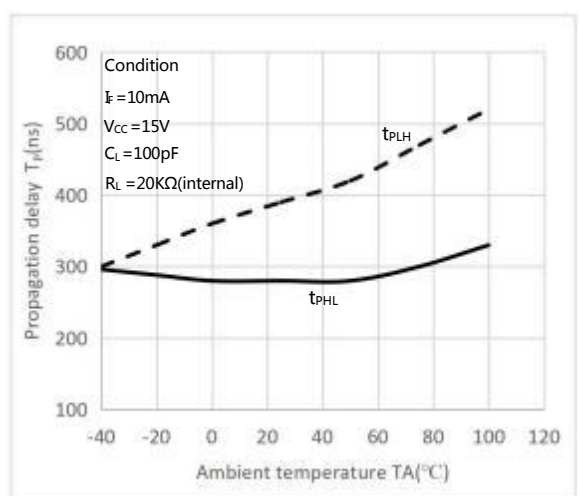

Fig.7 Propagation delay vs. load resistance

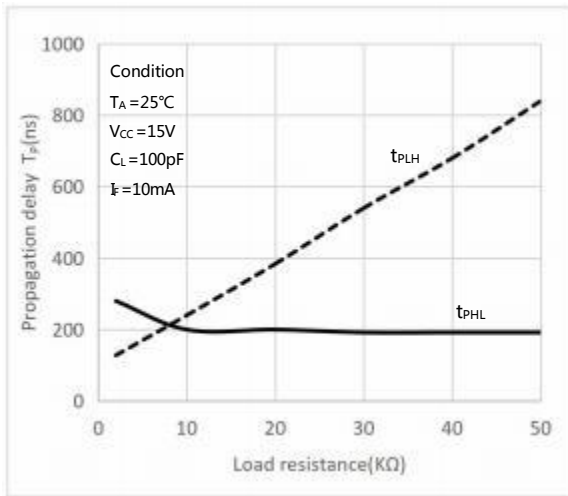

Fig.8 Propagation delay vs. load capacitance

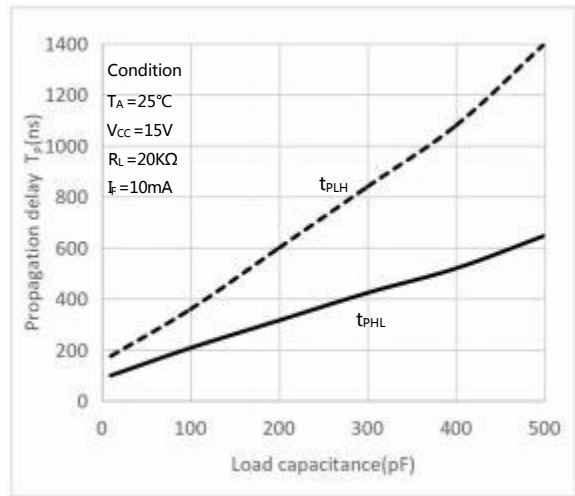

Fig.9 Propagation delay vs. supply voltage

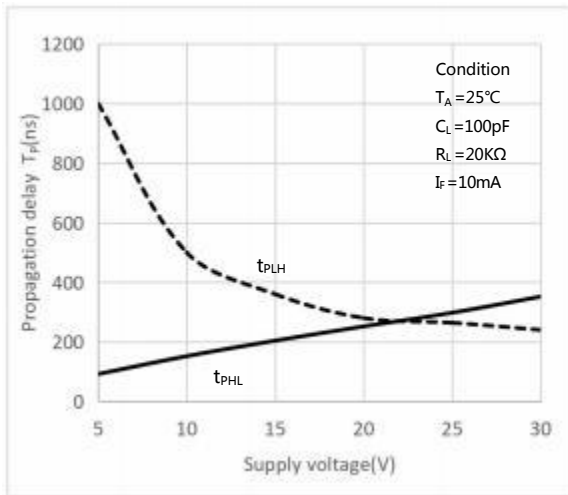
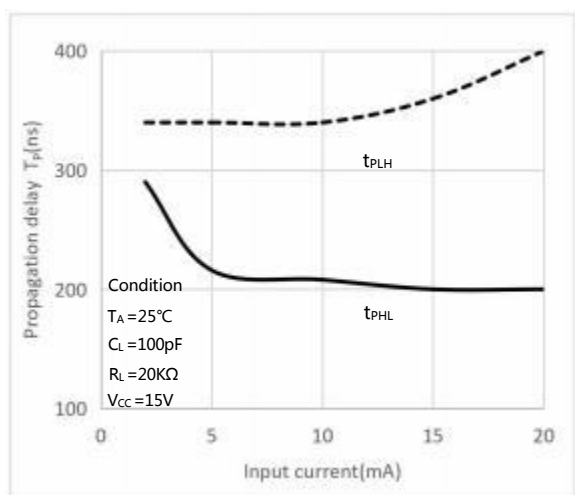
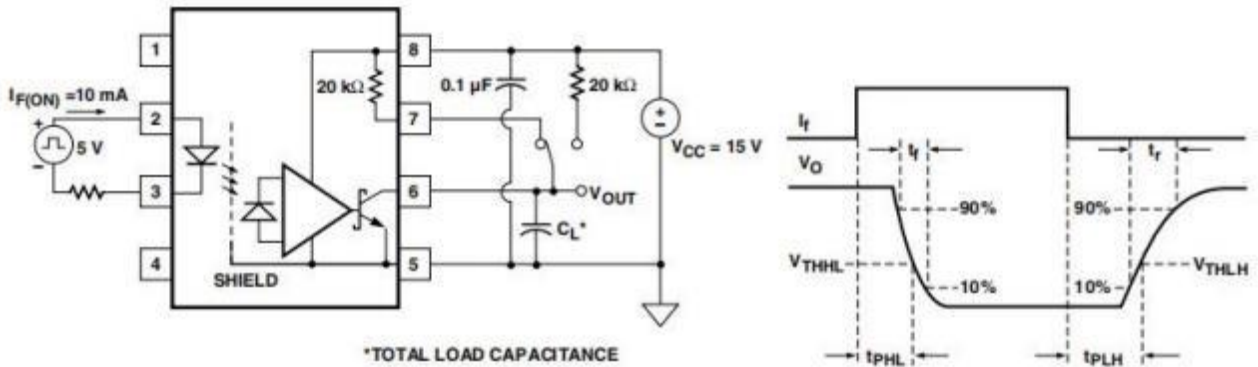

Fig.10 Propagation delay vs. input current



延迟时间测试电路 Propagation Delay Time Test Circuit



CMR 测试电路 Test Circuit for Common Mode Transient Immunity

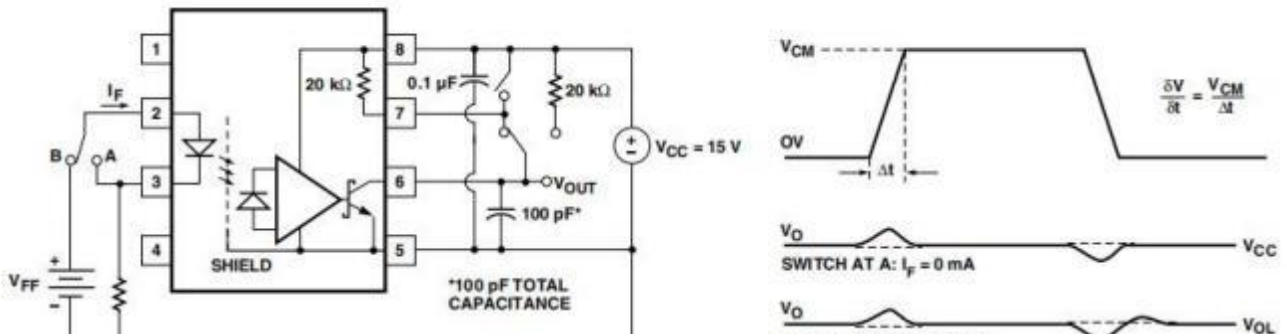

推荐 LED 驱动电路 Recommended LED Drive circuit

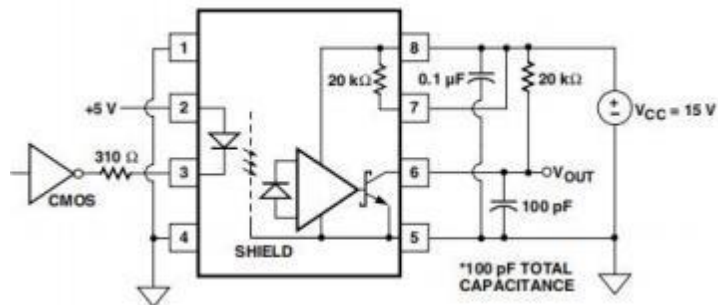

非屏蔽光耦器的光耦器输入到输出电容模型

Optocoupler input to output capacitance model for unshielded optocouplers

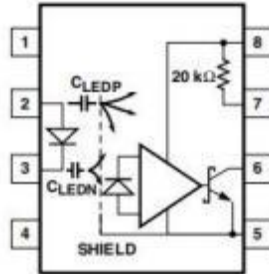

屏蔽光耦器的光耦输入输出电容模型

Optocoupler input to output capacitance model for shielded optocouplers

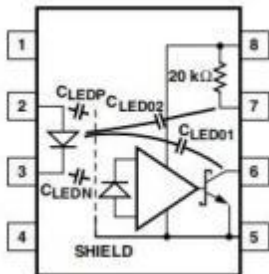

LED 驱动电路与电阻连接的 LED 阳极 (不推荐)

LED drive circuit with resistor connected to LED anode (not recommended)

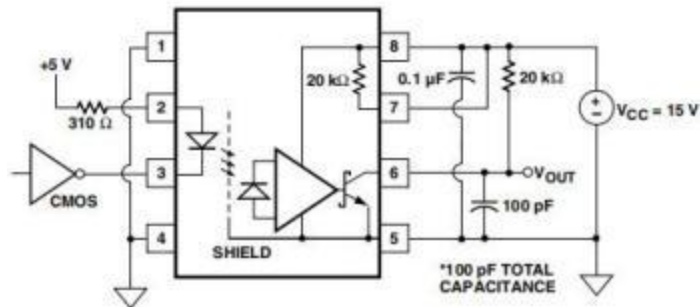

超高 CMR 推荐 LED 驱动电路

Recommended LED drive circuit for ultra high CMR

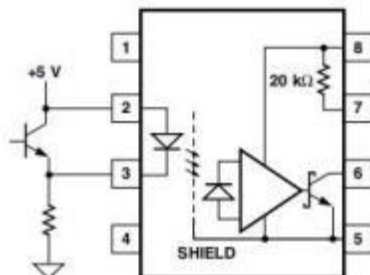

外形尺寸 Outline Dimensions

DIP8

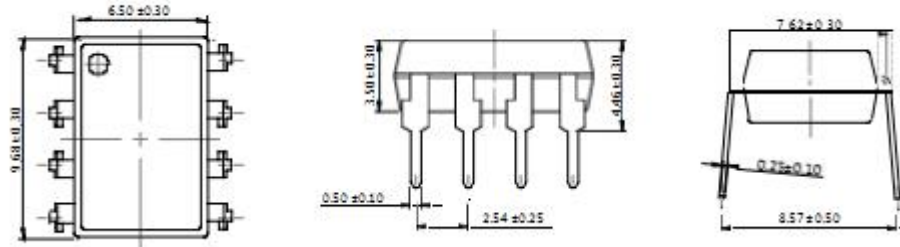

SMD8

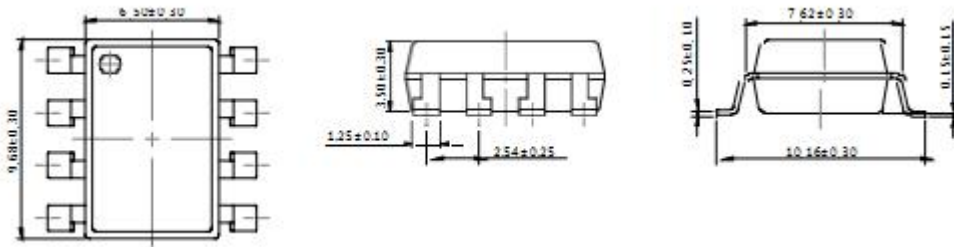

单位 Unit: mm

建议焊盘布局 Recommended Pad Layout

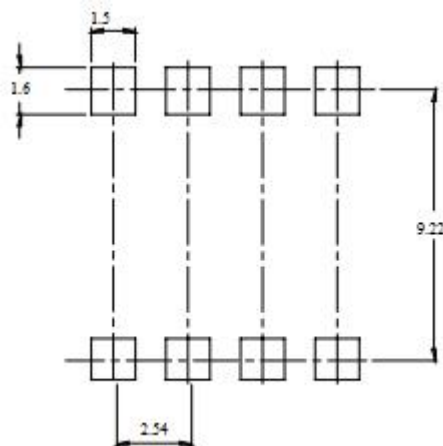

单位 Unit: mm

注：上图为产品正视图。

Note : The picture above is the front view of the product.

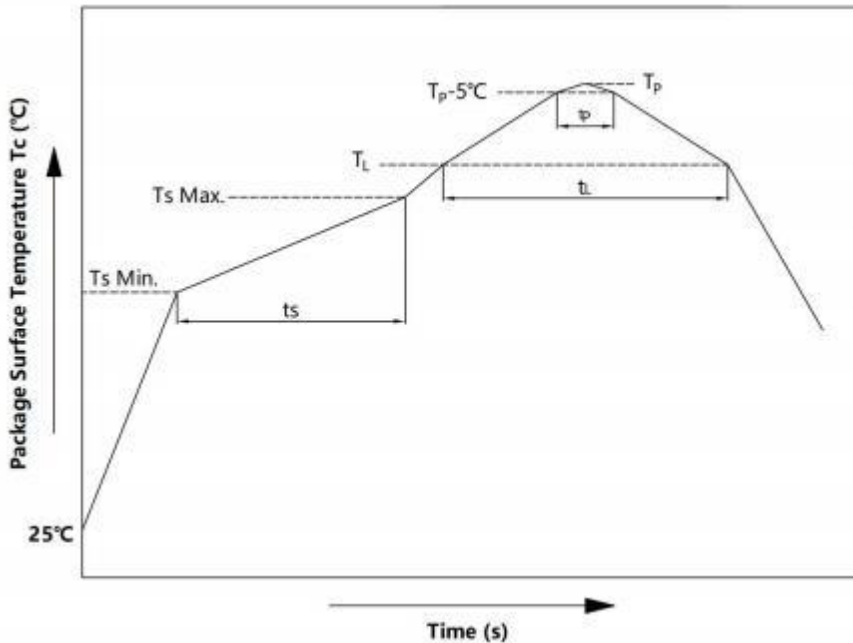
回流焊温度曲线图 Solder Reflow Profile

项目 Item	符号 Symbol	最小值 Min.	最大值 Max	单位 Unit
预热温度 Preheat Temperature	Ts	150	200	°C
预热时间 Preheat Time	ts	60	120	s
升温速率 Ramp-Up Rate (T _L to T _P)	-	-	3	°C/s
液相线温度 Liquidus Temperature	T _L	217		°C
时间高于 T _L Time Above T _L	t _L	60	150	s
峰值温度 Peak Temperature	T _P	-	260	°C
Tc 在(T _P -5)和 T _P 之间的时间 Time During Which Tc Is Between (T _P -5) and T _P	t _p	-	30	s
降温速率 Ramp-down Rate(T _P to T _L)	-	-	6	°C/s

注 Note :

建议在所示的温度和时间条件下进行回流焊，最多不能超过三次；

Reflow soldering is recommended at the temperatures and times shown, no more than three times;

波峰焊温度曲线图 Wave Soldering Profile

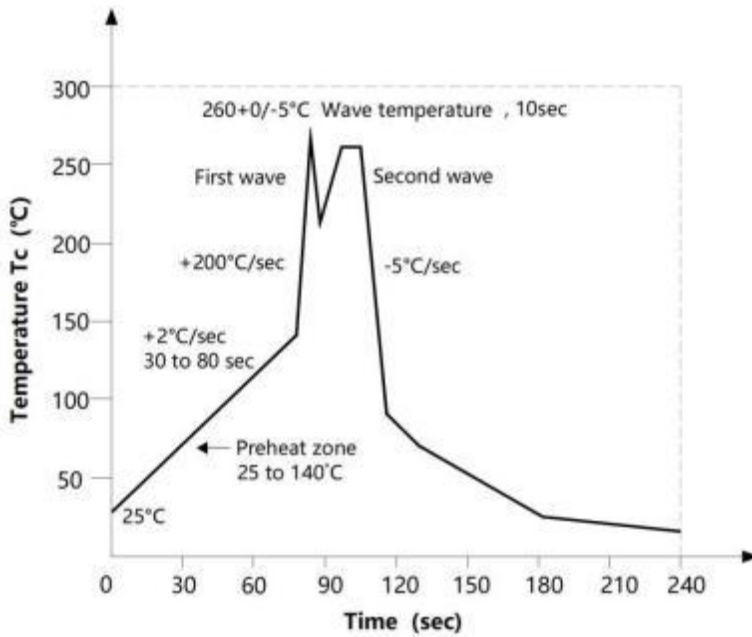

手工烙铁焊接 Soldering with hand soldering iron

- A. 手工烙铁焊仅用于产品返修或样品测试；
Hand soldering iron is only used for product rework or sample testing;
- B. 手工烙铁焊要求：温度 $360^{\circ}\text{C} \pm 5^{\circ}\text{C}$ ，时间 $\leq 3\text{s}$ 。
Hand soldering iron requirements：Temperature： $360^{\circ}\text{C} \pm 5^{\circ}\text{C}$, within 3s.

包装 Packing

■ 汇总表 Summary table

封装形式	包装方式	盘数量	盒数量	箱数量	静电袋规格	盒规格	箱(双瓦楞)规格	备注
SMD8	卷盘 ($\phi 330$ mm 蓝盘)	1k/盘	2 盘/盒	10 盒/箱	450*390*0.1mm	340*60*340mm	380*360*365mm	首端空 50 个空格， 末端空 100
DIP8	管装 (500*12*11mm)	45/管	50 管/盒	10 盒/箱	不适用	525*128*56mm	535*275*300mm	每管使用蓝白胶塞， 方向须一致
Package Type	Packing Form	Quantity per Reel	Quantity per Box	Quantity per Carton	Antistatic Bag Specification	Box Specification	Carton Specification	Note
SMD8	Reel ($\phi 330$ mm Blue)	1Kpcs/reel	2reels/box	10boxes /ctn	450*390*0.1mm	340*60*340mm	620*360*365 mm	Leave 50 Spaces at the beginning and 100 Spaces at the end
DIP8	Tube (500*12*11mm)	45pcs /tube	50tubes /box	10boxes /ctn	NA	525*128*56mm	535*275*300 mm	Endplug (blue) and Endplug (white) keep the direction

■ 条管包装 Tube

- 1) 每箱数量：22500 只。
Qty/ctn : 22500pcs
- 2) 内包装：Inner packing :
 - i. 每条管 45 只。
45pcs/tube
 - ii. 每盒 50 条管。
50 tubes/box
- 3) 示意图 Schematic :

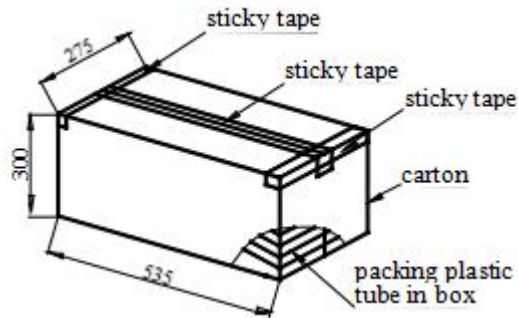

■ 编带包装 Tape & Reel

- 1) 每卷数量：1000 只。
Qty/reel : 1000 pcs.
- 2) 每箱数量：20000 只。
Qty/ctn : 20000 pcs.
- 3) 内包装：每盒 2 盘。
Inner packing : 2 reels/box.
- 4) 示意图 Schematic :

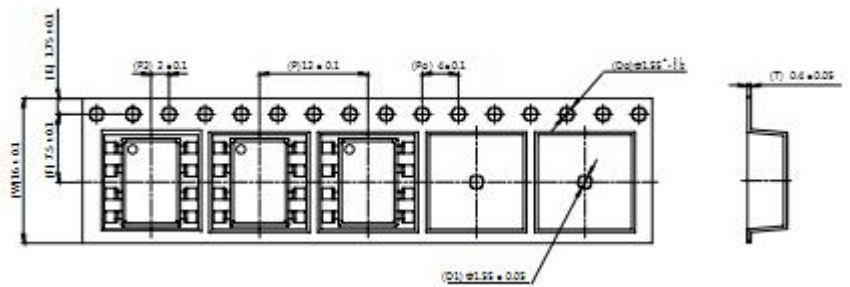

单位 Unit : mm

注意 Attention

- 奥特持续不断改进质量、可靠性、功能或设计，保留此文件更改的权利恕不另行通知。
AOTE continuously improve quality, reliability, function and design. We reserve the right to change this document without prior notice.
- 请遵守产品规格书使用，奥特不对使用时不符合产品规格书条件而导致的质量问题负责。
Please use in accordance with the product specification. AOTE is not responsible for the quality problems caused by non-compliance with the product specifications.
- 对于需要高可靠性或安全性的设备/装置需求，请联系我们的销售人员。
For equipment/devices requiring high reliability or safety, please contact our sales representatives.
- 当需要用于任何“特定”应用时，请咨询我们的销售人员。
When requiring a device for any “specific” application, please contact our sales in advice.
- 如对文件中表述的内容有疑问，欢迎联系我们。
If you have any questions about the contents of the document, please contact us.

X-ON Electronics

Largest Supplier of Electrical and Electronic Components

Click to view similar products for [Transistor Output Optocouplers](#) category:

Click to view products by [AOTE](#) manufacturer:

Other Similar products are found below :

[LTV-814S-TA](#) [LTV-852S](#) [66095-001](#) [PS2561-1-A](#) [PS2561A-1-W-A](#) [PS2561L1-1-A](#) [PS2561L-1-V-A](#) [PS2706-1-A](#) [PS2815-1-A](#) [MRF658](#)
[ELD207\(TA\)](#) [ILD2-X006](#) [ILQ615-3X016](#) [LDA102S](#) [SFH615A-4XSM TR](#) [PS2561DL-1Y-F3-A](#) [PS2561L1-1-L-A](#) [PS2562-1-V-A](#) [PS2565L-](#)
[1-A](#) [PS2581L2-A](#) [PS2701A-1-F3-P-A](#) [PS2711-1-A](#) [PS2801-1-F3-P-A](#) [PS2833-4-A](#) [PS2841-4A-AX](#) [LTV-702FS](#) [LTV-702V](#) [LTV-702VB](#)
[LTV-816S-TA](#) [TCET2100](#) [TLP290-4\(E\(T](#) [IL215AT](#) [WPPC-A11066AA](#) [WPPC-A11066AD](#) [WPPC-A11084ASS](#) [WPPC-A21068AA](#) [WPPC-](#)
[D11066AA](#) [WPPC-D21068ED](#) [WPPC-D410616EA](#) [WPPC-D410616ED](#) [X4IAC24A](#) [4N26-X001](#) [EL1010\(TA\)-VG](#) [SFH600-2X007](#)
[TCMT1118](#) [VO206AT](#) [WPPC-D21068EA](#) [WPPC-D11064AD](#) [WPPC-A410616AD](#) [WPPC-A21068AD](#)